

1.5 μm photon-counting optical time-domain reflectometry with a single-photon detector based on upconversion in a periodically poled lithium niobate waveguide

Eleni Diamanti, Carsten Langrock, M. M. Fejer, and Yoshihisa Yamamoto

Edward L. Ginzton Laboratory, Stanford University, Stanford, California 94305-4088

Hiroki Takesue

NTT Basic Research Laboratories, NTT Corporation, 3-1 Morinosato Wakamiya, Atsugi-shi, Kanagawa 243-0198, Japan

Received August 11, 2005; accepted November 19, 2005; posted December 1, 2005 (Doc. ID 64027)

Optical time-domain reflectometry (OTDR) is one of the most powerful tools in the characterization of optical fiber links. We demonstrate a photon-counting OTDR system at 1.5 μm with a single-photon detector, which combines frequency upconversion in a periodically poled lithium niobate waveguide and a silicon avalanche photodiode. The system exhibits high sensitivity, good spatial resolution, and short measurement time.

© 2006 Optical Society of America

OCIS codes: 120.0280, 040.5570.

The optical time-domain reflectometry (OTDR) technique consists of sending a light pulse into an optical fiber and measuring the Rayleigh backscattered light. It is one of the most commonly used measurement techniques for nondestructive and spatially resolved optical fiber and system characterization. Although classical OTDR has been successful,¹ photon-counting OTDR (ν -OTDR), which employs a single-photon detector as the detection apparatus, has received increasing attention because of its better sensitivity and superior spatial resolution and the absence of the so-called classical dead zones. Several ν -OTDR experiments have been performed at the telecommunication wavelengths of 1.3 and 1.5 μm with either centimeter spatial resolution or very large dynamic range.²⁻⁴ In these implementations, Ge or InGaAs/InP avalanche photodiode detectors (APDs) are used. These single-photon detectors exhibit high afterpulse probability, which can cause significant distortion of the OTDR data.^{2,5} To reduce this effect these detectors have to be operated in a gated mode. For applications for which the arrival time of a signal photon is not known *a priori*, such as in OTDR, gated-mode operation complicates the measurement process significantly. Gated measurement windows have to be used for access only to parts of the fiber link at a time. However, even with gating, the effect of afterpulsing is still significant, and therefore post-signal-processing algorithms and (or) control of the detector-gate activation time is needed, which results in a long measurement time and a complex control system.²

In our experiment a 1.5 μm single-photon detector based on the principle of frequency upconversion⁶⁻¹⁰ is employed, for the first time to our knowledge, to implement a ν -OTDR system. In this detector, weak 1.56 μm radiation interacts with a strong pump at 1.32 μm in a periodically poled lithium niobate

(PPLN) waveguide designed for sum-frequency generation at these wavelengths.¹¹ This device allows photon conversion efficiency exceeding 99% of the signal at 1.56 μm to the near-infrared at 0.71 μm , which is subsequently detected by a silicon APD.⁸ Commercially available silicon-based single-photon counting modules (SPCMs) have high quantum efficiencies in the near-infrared, low dark-count rates, and negligible afterpulse probability. The last characteristic of the silicon APD permits Geiger (nongated) mode operation with an active quenching system, with a dead time as small as 50 ns and an afterpulse probability as low as 0.5%. This mode of operation results in a high-speed ν -OTDR system without any need for a complex control system.

To illustrate the advantage of the nongated upconversion detector in terms of reduced measurement time, we consider a simplified case. We assume that the backscattered light has a constant power for time duration T instead of a temporally decreasing power as in a real OTDR measurement. When a gated-mode InGaAs/InP APD is used, the signal photons are measured over a gate width Δt with a period t_g , and the gate position is changed to cover the entire time T . If n_g is the number of repeated measurements for each gate position, the total number N of photons to be collected is $N = n_g \eta \mu T$, where η is the quantum efficiency of the detector and μ is the number of photons per second in the signal. Overall measurement time T_g is given by the expression $T_g = n_g T t_g / \Delta t = N t_g / (\eta \mu \Delta t)$, where $t_g / \Delta t$ is the number of different gate positions. On the other hand, when an upconversion detector is used, no gating is needed, but dead time t_d of the silicon APD effectively alters the measured signal. In this case, if n_{ng} is the number of repeated measurements, the total number N of photons is $N = n_{ng} \eta \mu T \exp(-\eta \mu t_d)$. The overall measurement

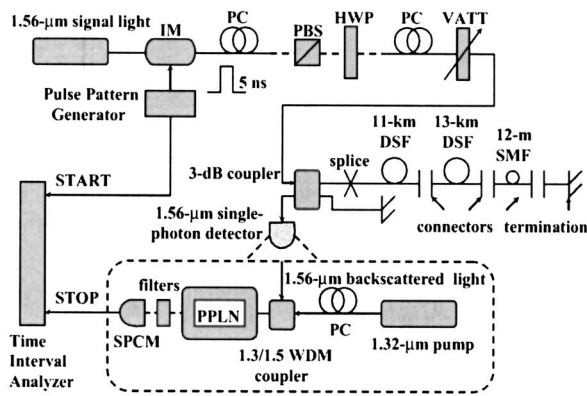

Fig. 1. Experimental setup for the $1.5 \mu\text{m}$ v -OTDR measurement: IM, intensity modulator; PCs, polarization controllers; PBS, polarizing beam splitter; HWP, half-wave plate; VATT, variable attenuator; SMF, single-mode fiber; DSFs, dispersion-shifted fibers; WDM, wavelength-division multiplexer.

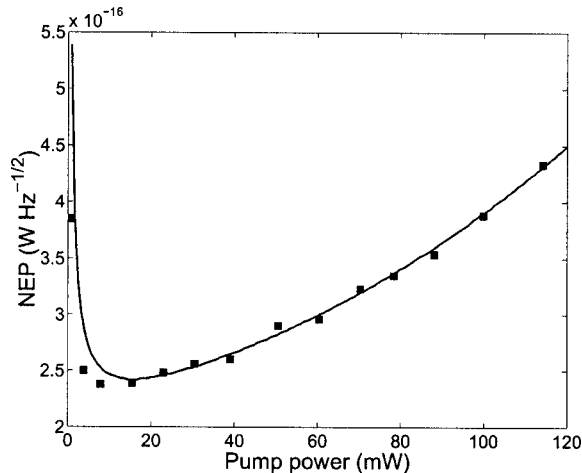

Fig. 2. NEP of the upconversion single-photon detector as a function of the pump power. The solid curve was derived from the fitting curves of the quantum-efficiency and dark-count experimental data.

time T_{ng} is given by the expression $T_{ng} = n_{ng} T = N / [\eta \mu \exp(-\eta \mu t_d)]$. Assuming the same η for both detectors, as well as the same N and μ values, the expressions for T_g and T_{ng} give $T_g / T_{ng} = \exp(-\eta \mu t_d) t_g / \Delta t$. Then, for the typical values $t_g \sim 1 \mu\text{s}$, $\Delta t \sim 1 \text{ns}$, and $t_d \sim 50 \text{ns}$, and given that the SPCM count rate per second, $\eta \mu$, can reach 10 Mcounts/s, we find $T_g / T_{ng} \geq 0.6 \times 10^3$. This simple argument shows that a v -OTDR system almost 3 orders of magnitude faster than with an InGaAs/InPAPD is possible with the upconversion detector.

The experimental setup is shown in Fig. 1. The $1.56 \mu\text{m}$ cw signal light enters an optical intensity modulator controlled by a 200 MHz pulse pattern generator. A train of 5 ns pulses with a repetition rate of 4 kHz is generated. The pulse peak power at the input of the OTDR system is controlled by a variable attenuator and was set at -2.6dBm for the measurement. The pulses enter a 3 dB coupler, one of the output ports of which is connected to the fibers under test. We used a combination of an 11 km dispersion-

shifted fiber, a 13 km dispersion-shifted fiber, and a 12 m standard single-mode fiber. The Rayleigh backscattered light and the strong Fresnel reflections from the connecting points enter the upconversion single-photon detector. There, the light is combined in a wavelength-division multiplexer with a strong pump and enters the fiber-pigtailed PPLN waveguide device. Separation of the converted signal, pump, and spurious light after the waveguide is achieved with a combination of filters.⁸ The light is then detected by the SPCM. Data were taken using the output electrical pulses of the pulse pattern generator and the SPCM to trigger a picosecond time-interval analyzer. Gating of the detector was not required, and data from the entire fiber link were taken continuously. The birefringence of the fiber induces time-dependent fluctuation of the polarization of the backscattered light. On the other hand, the performance of the upconversion detector is polarization dependent. To overcome this problem, the polarization of the input light was set by the half-wave plate shown in Fig. 1. Experimental data were taken for both horizontal and vertical polarization inputs and were subsequently added. Note that solutions to the polarization dependence of the upconversion detector, such as the polarization-diversity and Sagnac approaches, are under investigation.

The choice of the operating point of the single-photon detector is of great importance for a v -OTDR system. The OTDR system's sensitivity is determined by the noise-equivalent power (NEP) of the detector, defined as $\text{NEP} = h\nu\sqrt{2D}/\eta$, where $h\nu$ is the energy of the signal photon, D is the dark-count rate, and η is the quantum efficiency. In the case of the upconversion detector the dark-count rate is determined by spurious nonlinear processes inside the fiber and the waveguide.⁸ These processes scale with the pump power. Therefore the dark-count rate and consequently the NEP of the detector are functions of the pump power. This is shown in Fig. 2, which depicts experimental data for the upconversion detector employed in our experiment. The NEP takes a minimum value of $2.4 \times 10^{-16} \text{W Hz}^{-1/2}$, which corresponds to an

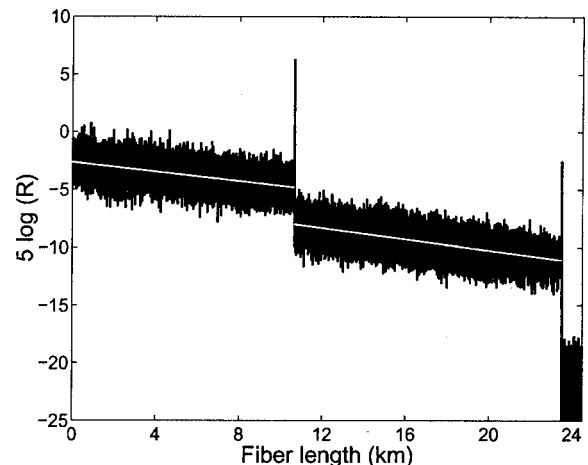

Fig. 3. v -OTDR measurement result for the links of 11 km, 13 km, and 12 m fibers. R is the backscattered signal power normalized by its value at the splice point.

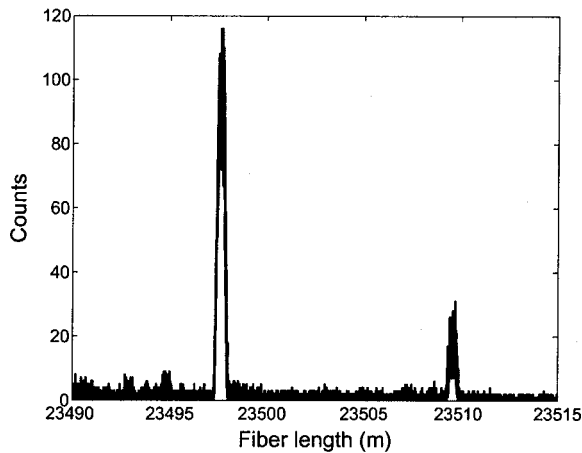

Fig. 4. Time-interval analyzer data for the 12 m fiber, indicating the 1 m spatial resolution of the ν -OTDR system.

input pump power at the entrance of the waveguide of 8 mW, $D=5.7 \times 10^3$ counts/s, and $\eta=5.8\%$. These conditions were chosen as the operating point of our experiment.

The ν -OTDR experimental data are shown in Figs. 3 and 4. In Fig. 3 the measurement result for the backscattered signal power from the entire fiber link of 24 km is shown as a function of distance. The measurement time was 12 min. The statistical noise is rather large but can be significantly decreased by increasing the measurement time. A linear fit of the data that correspond to the two long fibers gives the values 0.21 and 0.24 dB/km for the loss coefficient of the 11 and 13 km fibers, respectively. The exact lengths of the fibers can also be determined from this measurement and are 10.650 and 12.848 km, respectively. We can observe the large Fresnel reflections from the connecting points as well as the loss of 3.2 dB at the connection between the two fibers. A typical figure of merit for OTDR systems is the dynamic range, as it essentially determines the maximum measurement distance.¹ From the background-noise level shown in Fig. 3 we can determine the peak dynamic range of our system to be 16 dB, which corresponds to a loss of 80 km of fiber. This means that measurement of up to 80 km of fiber is possible with our system, without changing the input power. The fact that we are able to measure this long distance in a short time is due to the nongated mode operation of the upconversion single-photon detector, as well as the increased sensitivity achieved by careful tuning of the pump power. The dynamic range is limited in our case by the maximum peak input power that we are allowed to let into the SPCM to avoid saturation of the detector owing to the large-power backscattered light at the leading edge. We can significantly increase the dynamic range by measuring different segments of the fiber link with different input powers, which can be realized, for example, by inserting a temporal switching function at the detector side. An-

other approach could be to appropriately gate the 1.3 μm pump to avoid upconversion during the back-scattering from the leading edge.

The spatial resolution of our ν -OTDR system is explored in Fig. 4. A graph of the time-interval analyzer data over the 12 m fiber after 6 min of measurement time is shown. We can clearly observe two reflection peaks, indicating that we can detect a 12 m fiber after a distance of 24 km with a spatial resolution of 1 m, determined by the 5 ns pulse width. Clearly, using shorter pulses in the same system will readily provide centimeter resolution.

In conclusion, we have presented a 1.5 μm photon-counting OTDR system that employs a single-photon detector that combines frequency upconversion in a PPLN waveguide and a silicon APD operating in nongated mode. The use of this detector allows us to perform a continuous and fast ν -OTDR measurement with a simple and practical control system that does not require gate trains or post-signal-processing algorithms. Our system exhibits a dynamic range of 16 dB, which corresponds to measurement of up to 80 km of fiber without changing the input power, and 1 m spatial resolution. Measuring different segments of the fiber link with different input powers and using shorter pulses can significantly improve the performance of the system.

This work was supported by the Multi University Research Initiative (MURI) Center for Photonic Quantum Information Systems (U.S. Army Research Office-Advanced Research and Development Activity DAAD19-03-1-0199) and the Quantum Entanglement Project Solution Oriented Research for Science and Technology (SORST), Japan Science and Technology Corporation (JST). Diamanti's e-mail address is ediam@stanford.edu.

References

1. D. Derickson, *Fiber Optic Tests and Measurement* (Prentice-Hall, 1998).
2. M. Wegmüller, F. Scholder, and N. Gisin, *J. Lightwave Technol.* **22**, 390 (2004).
3. F. Scholder, J.-D. Gautier, M. Wegmüller, and N. Gisin, *Opt. Commun.* **213**, 57 (2002).
4. A. Lacaita, P. A. Francesco, S. Cova, and G. Ripamonti, *Opt. Commun.* **18**, 1110 (1993).
5. G. Ripamonti, F. Zappa, and S. Cova, *J. Lightwave Technol.* **10**, 1398 (1992).
6. J. Huang and P. Kumar, *Phys. Rev. Lett.* **68**, 2153 (1992).
7. G. Giorgi, P. Mataloni, and F. De Martini, *Phys. Rev. Lett.* **90**, 027902 (2003).
8. C. Langrock, E. Diamanti, R. V. Roussev, Y. Yamamoto, M. M. Fejer, and H. Takesue, *Opt. Lett.* **30**, 1725 (2005).
9. M. A. Albota and F. N. C. Wong, *Opt. Lett.* **29**, 1449 (2004).
10. A. P. Vandevender and P. G. Kwiat, *J. Mod. Opt.* **51**, 1433 (2004).
11. R. V. Roussev, C. Langrock, J. R. Kurz, and M. M. Fejer, *Opt. Lett.* **29**, 1518 (2004).