

# 18 kW Three Phase Inverter System Using Hermetically Sealed SiC Phase-Leg Power Modules

Hui Zhang<sup>1</sup>, Leon M. Tolbert<sup>2,4</sup>, Jung Hee Han<sup>3</sup>, Madhu S. Chinthavali<sup>4</sup>, Fred Barlow<sup>5</sup>

<sup>1</sup>Electrical Engineering Department  
Tuskegee University  
Tuskegee, AL 36088

<sup>2</sup>Electrical Engineering and Computer Science  
The University of Tennessee  
Knoxville, TN 37996-2100

<sup>3</sup>Global Power Electronics  
27 Mauchly Ste 206  
Irvine, CA 92618

<sup>4</sup>Power Electronics and Electric Machinery Research Center  
Oak Ridge National Laboratory  
Knoxville, TN 37932

<sup>5</sup>Electrical and Computer Engineering  
University of Idaho  
Moscow, Idaho 83844-1023

**Abstract**—Power electronics play an important role in electricity utilization from generation to end customers. Thus, high-efficiency power electronics help to save energy and conserve energy resources. Research on silicon carbide (SiC) power electronics has shown their better efficiency compared to Si power electronics due to the significant reduction in both conduction and switching losses. Combined with their high-temperature capability, SiC power electronics are more reliable and compact. This paper focuses on the development of such a high efficiency, high temperature inverter based on SiC JFET and diode modules. It involves the work on high temperature packaging (>200 °C), inverter design and prototype development, device characterization, and inverter testing. A SiC inverter prototype with a power rating of 18 kW is developed and demonstrated. When tested at moderate load levels compared to the inverter rating, an efficiency of 98.2% is achieved by the initial prototype without optimization, which is higher than most Si inverters.

**Keywords**—Silicon Carbide (SiC), SiC JFET, Efficiency, High temperature, Inverter, Packaging.

## I. INTRODUCTION

Power electronics is the technology that enables the efficient generation, transmission, distribution, utilization, and storage of electricity. Today 40% of energy consumption is electrical energy, more than 50% of which is controlled by power electronics and will only increase in the future [1]. For example, in electricity generation, especially for renewable technologies such as solar, wind, etc, power electronics are inevitable to work as power interface with the grid or connected loads, or as the interface for energy storage[2][3]. Another example, today's motor drives consume 50%-60% of all electricity consumption [4]. With application of power electronics as controller to motor drives, tremendous energy savings can be achieved [5-6]. Thus, high efficiency and high

reliability power electronics are needed in every steps of electricity utilization from generation to end customers.

Research on SiC power electronics has revealed their better efficiency compared to Si power electronics due to the significant reduction in both conduction and switching losses [7-10]. Presently, Si IGBTs are commonly used switching component in a converter because of the low conduction and well controllable gate. These bipolar Si devices are supposed to be substituted by SiC unipolar devices such as JFETs and MOSFETs which have low switching losses and can switch fast due to the absence of minority carriers. Similarly, SiC diodes can also take the place of Si PiN diodes as freewheeling diodes because of the negligible reverse recovery current.

Furthermore, with a high-temperature package, the high temperature capability of SiC power electronics can be utilized [11]. Consequently, SiC based systems are more reliable and compact in high temperature applications such as aircraft, automobile, space exploration, deep gas/oil extraction, geothermal, etc [12-13]. This work will focus on the development and demonstration of such a high efficiency, high temperature inverter. The inverter performance will also be illustrated and confirmed by experiments.

## II. DESIGN AND DEVELOPMENT OF SiC MODULE

Towards high efficiency and high temperature SiC inverter, a SiC JFET-based phase leg module with hermetic metal housing is developed as shown in Fig. 1(a). The package is designed to work at a temperature of at least 200 °C ambient. More details will be given in the Section II.A. Each module is for a single phase leg and is composed by six 1200 V SiC JFETs (normally-on) and two 1200 V Schottky diodes from SiCED as well as a thermistor to detect the temperature inside the module (see Fig. 1(b)). Three SiC JFETs are in parallel in

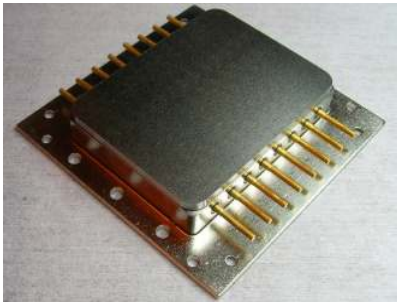

(a) CTE-matched metal lid and housing.

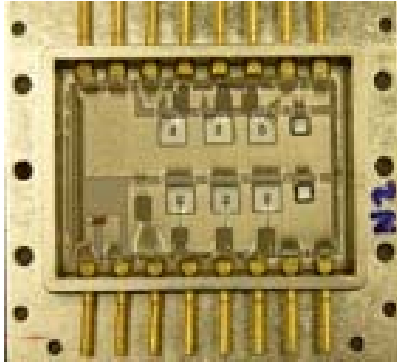

(b) Six SiC JFETs and two SiC Schottky diode attached to substrate and are wire bonded with aluminum alloy wire.

Fig. 1. SiC JFET phase leg module with hermetic metal housing.

order to achieve a higher current rating ( $\sim 30\text{A}$ ). To verify their performance, high temperature testing is conducted, and the details are shown in the Section II.B.

#### A. Package Development

The packages used in this inverter were built based on hermetic metallic housings and direct bond copper (DBC) substrates as shown in Fig. 2. Metal housings were selected due to the high reliability associated with these packages even at temperatures well above  $200^\circ\text{C}$ . The use of coefficient of expansion (CTE) matched metals, and glass isolated electrical connections ensures thermal and mechanical stability far superior to traditional plastic modules.

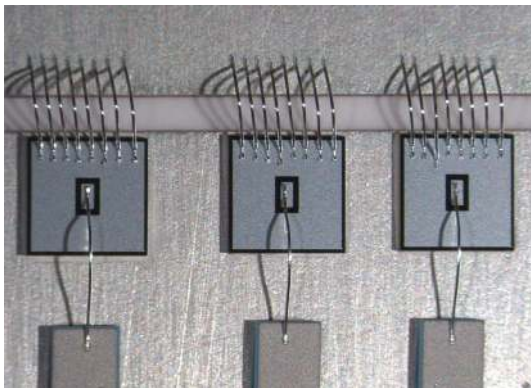

Fig. 2. SiC JFETs bonded to a DBC BeO substrate within the power modules housing.

Each individual module contains a single DBC substrate that is used to interconnect the SiC based diodes and JFETs. Beryllium oxide (BeO) was chosen for the substrate in this application due to its superior thermal performance, but versions of this module could also be fabricated with Alumina ( $\text{Al}_2\text{O}_3$ ) or Aluminum Nitride (AlN) substrates, with slightly lower thermal performance [14-17]. The SiC devices were attached to these substrates through the use of a polyimide based conductive adhesive. This adhesive is stable to well above  $200^\circ\text{C}$  and therefore can be used when many of the traditional solders would melt.

The SiC devices were then wire bonded with aluminum alloy wire to form the connections between the die, substrate traces, and external electrical connections. In modules of this nature the metallization must be carefully considered to avoid failures caused by inter-metallic alloy formation at the die wire bond interface, or the substrate wire bond interface. If selected inappropriately inter-diffusion, which is accelerated at high temperatures, can lead to void formation and a reduction in the strength of the bond welds. The most famous case is the Al / Au inter-metallic [18] but similar effects have been observed in the Al / Cu system [19]. In this case a surface finish of Nickel was selected since it has been established that the Ni / Al system is far more stable at high temperatures than many of the alternative systems [20-22].

After assembly of the modules, a low modulus encapsulation was used to suppress arcing in and around the die and wire bonds within the metal housings. This material is applied in a liquid state and therefore flows around the structures within the module. Once cured it becomes a soft rubber like material that is stable to temperatures greater than  $200^\circ\text{C}$ . A detailed analysis of this material indicates no change in the breakdown voltage even after more than 1000 hours of exposure to high temperatures. Finally, a CTE matched metal lid was sealed in place.

#### B. Characterization of the SiC JFET Modules

The SiC JFET Modules are tested at different ambient temperatures from  $25^\circ\text{C}$  to  $200^\circ\text{C}$  with an increment of  $25^\circ\text{C}$ . As expected, at static state, the on-state resistances of both JFETs and diodes in the modules increase with temperature, as shown as Fig. 3(a) and 3(b). Compared to those comparable Si devices, not only the resistance values but also the variation with temperature is smaller. Thus, the SiC devices are more efficient in terms of conduction loss. The transfer characteristics of the JFETs in Fig. 3 (c) are nearly constant for tested temperatures. This means that the switching losses of the JFETs will not significantly change with temperature. This is also confirmed by the switching tests.

The two switches in the modules are also tested individually using the circuit shown in Fig. 4 at the temperature range from  $25^\circ\text{C}$  to  $200^\circ\text{C}$  with the increment of  $50^\circ\text{C}$ . With a pure inductive load, the current in the switches can be controlled by adjusting the duty ratio of the first pulse when applying a double-pulse control signal. Commercial gate driver IC HCNW3120 is selected to drive the SiC JFETs. With proper design of power supplies voltages, the gate driver IC can generate  $-20\text{V}$  to turn off the JFETs, and  $0\text{V}$  for turn on.

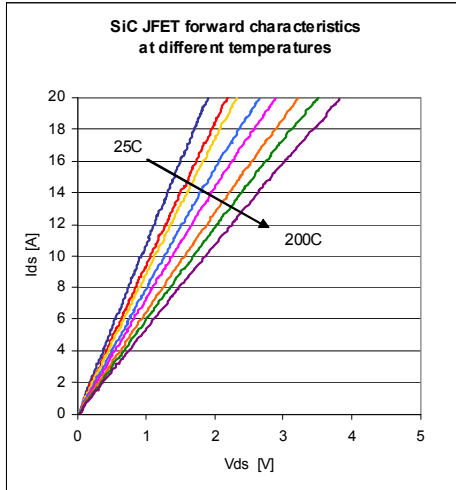

(a) SiC JFETs forward characteristics

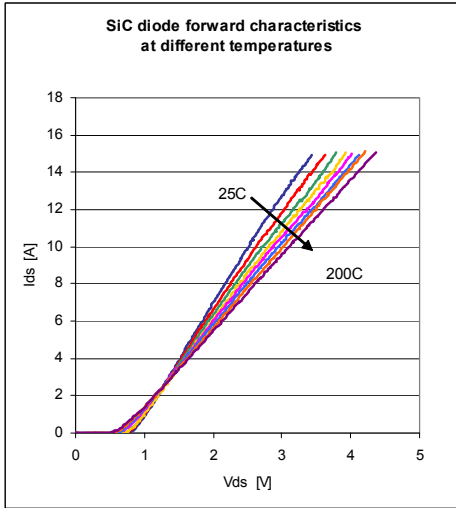

(b) SiC diodes forward characteristics

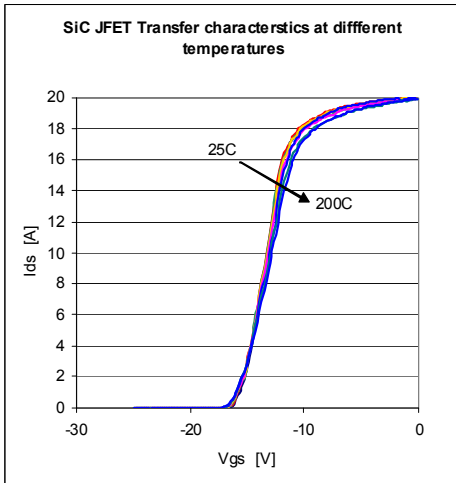

(c) SiC JFETs transfer characteristics

Fig. 3. Static characteristics of the SiC module.

The gate current of JFETs for the worse case at the temperature of 200 °C and the drain current of 8 A is shown in Fig. 4. The peak gate current is about 1.6 A when using a gate resistance of 5 Ω.

With the aforementioned gate drive design, the real switching waveform of the JFETs without any snubber at a test condition of 200V (dc bus voltage), 10A (drain current) and 200°C (ambient temperature) is shown in Figure 5. The switching losses including both turn-on loss and turn-off loss are calculated at each test condition. They are plotted versus the drain current at each tested temperature in Fig. 6. The switching losses in the SiC devices are almost constant (increase only slightly) when temperature increases, while the increase of the switching losses of Si devices is much more obvious. Thus, the substitution of SiC devices for Si devices will improve system efficiency, and the higher temperature and the higher frequency, the more benefits that the system will gain.

### III. EXPERIMENTS AND SiC INVERTER EFFICIENCY

A SiC inverter is built using three of the SiC modules shown in Fig. 1(a). The dimension of the inverter is 25 cm × 10 cm × 11 cm including the extruded heatsink and control boards (see Fig. 6).

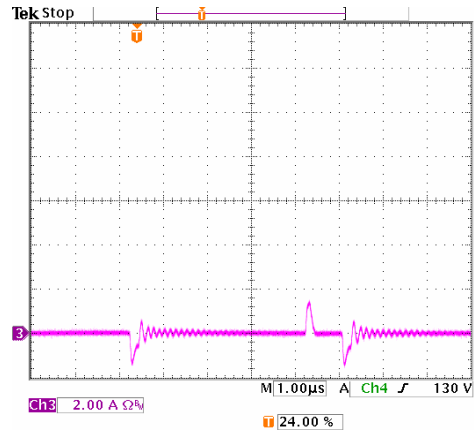

Fig. 4. Gate current waveform @200V/8A/200°C.

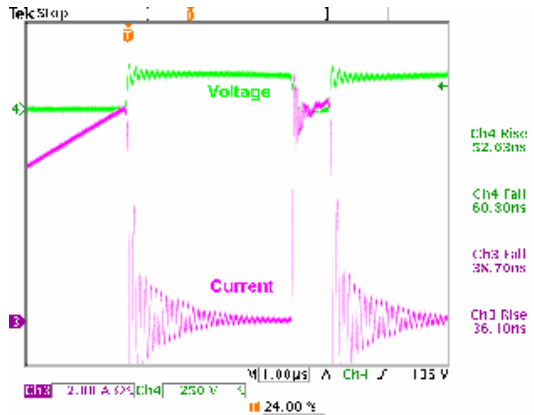

Fig 5. Switching waveform of the SiC JFETs @200V/10A/200°C

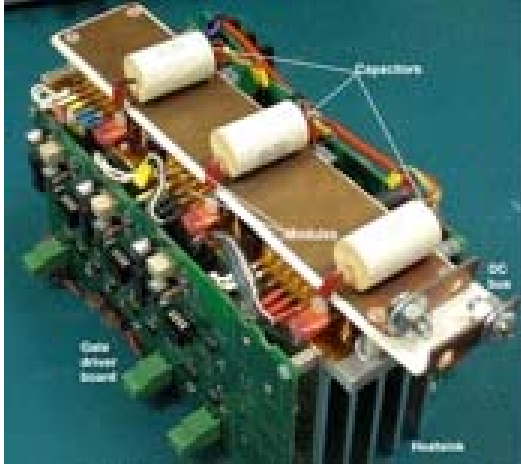

Fig. 6. Prototype SiC JFET inverter

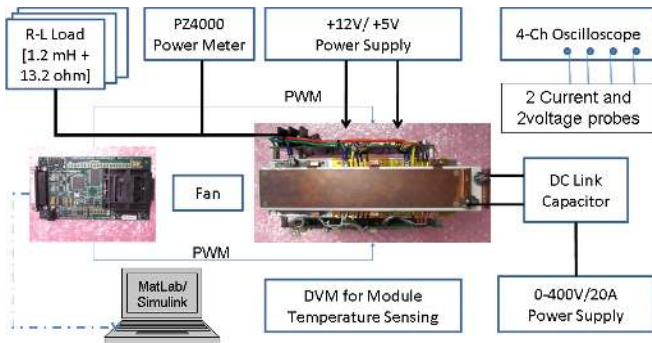
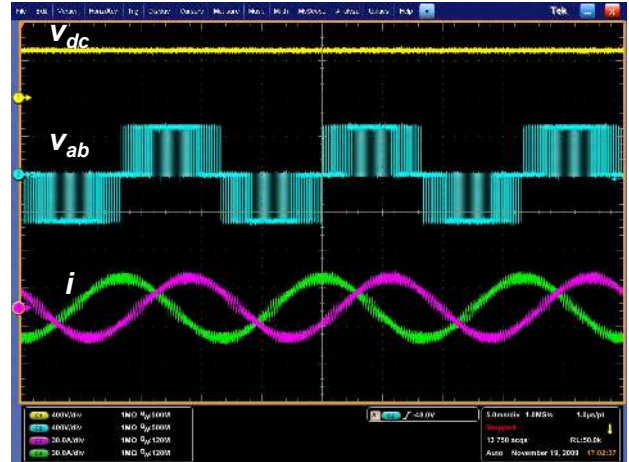

Fig. 7. Experimental system setup

The SiC inverter is tested with an RL load. As shown in Fig. 7, the inverter is connected to a DC power supply and feeds ac power to a 3-phase RL load, where  $R=10\ \Omega$  and  $L=2\ \text{mH}$ .

The switches in the inverter are controlled by SVPWM signals generated by the DSP board. The control program is developed in Matlab Simulink, and controllable parameters can be modified on line. The input DC voltage, current and 3-phase output voltage, current are monitored and measured by oscilloscope and PZ4000. Some of experimental waveforms of input voltage, output voltage and output current are shown in Fig. 8. The input voltage in the figure is 500 V. The frequency of the output voltage is 60 Hz, and its magnitude is set by a modulation index of 0.85. As shown from Fig. 8(a)-(c), the output current on the ac side is a clean sinusoidal waveform, and closer to a fine sinusoidal waveform at increasing switching frequency.

The values of input and output current/voltage are recorded using PZ4000. The input power and output power are also calculated by PZ4000. Then, the power loss and efficiency of the inverter can be calculated based on this information. Fig. 9 shows the inverter efficiencies at 60 Hz fundamental output frequency with a modulation index of 0.85 and three different switching frequencies (10, 15, 20 kHz). The maximum efficiency, 98.2%, is achieved at a switching



(a) at 5 kHz

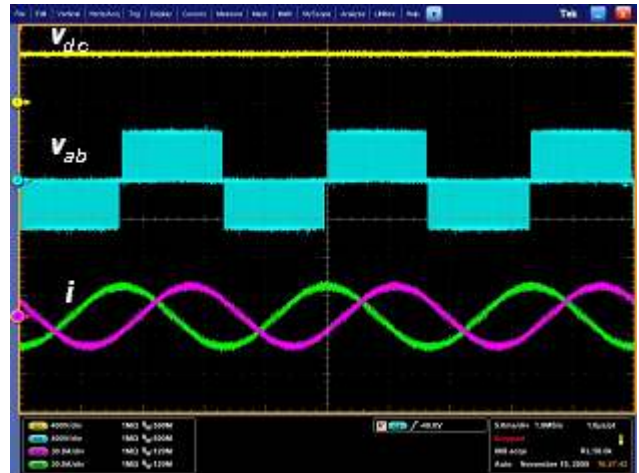

(b) at 10 kHz

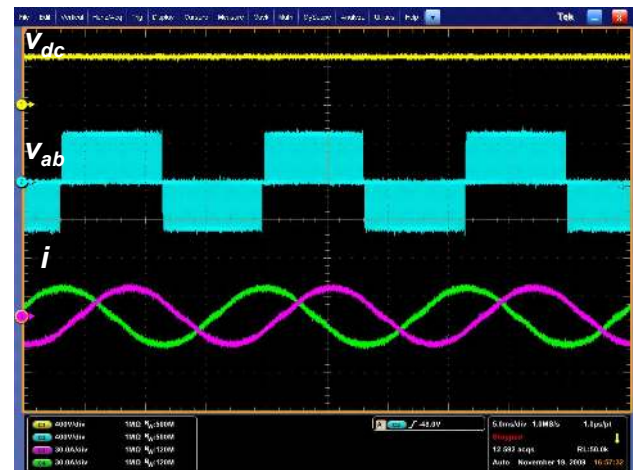

(c) at 20 kHz

Fig. 8. Experimental waveforms of the SiC inverter at 500 Vdc.



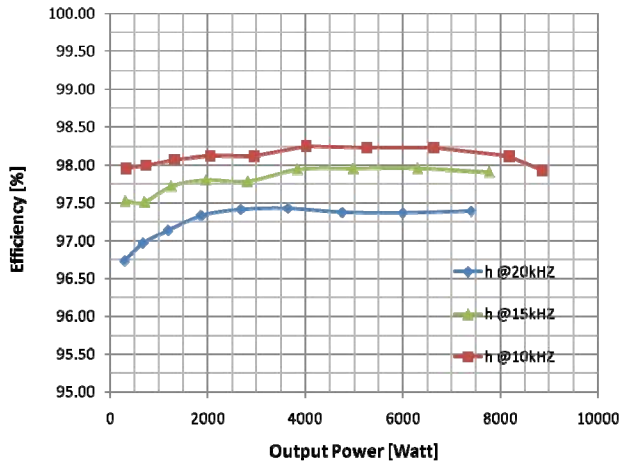

Fig. 9. Efficiency of the SiC inverter at different output power levels and switching frequencies.

frequency of 10 kHz at 4 kW output power range. The temperature inside the modules is less than 100 °C at this operating condition. If further increase the output power over about 8 kW, the module temperatures will increase quickly as monitored by the thermistors inside the package. This indicates that the cooling capability of the present heatsink design is not enough for the power-level over 8 kW.

#### IV. CONCLUSIONS AND FUTURE WORK

SiC phase-leg modules with high-temperature package (200 °C) are designed and demonstrated. Each switch inside the modules is composed of three SiC JFETs (1200V/10V) in parallel. A SiC inverter composed of three such modules is developed and tested. It achieves efficiency as high as 98.2%. To fully utilize the device ratings and achieve better efficiency, the cooling capacity of present heatsink needs to be improved. This may involve the work of further improving the packaging technique, optimizing the thermal management, and selecting high temperature passive components.

#### REFERENCES

- [1] European Center for Power Electronics (ECPE), "Position paper on energy efficiency – the Role of power electronics," [http://www.ecpe.org/download/power\\_electronic/Position\\_Paper\\_Energy\\_Efficiency.pdf](http://www.ecpe.org/download/power_electronic/Position_Paper_Energy_Efficiency.pdf), March 2007.
- [2] F. Blaabjerg, Z. Chen, "Power electronics as an enabling technology for renewable energy integration," *Journal of Power Electronics*, vol. 3, no. 2, pp. 81-89, Apr. 2003.
- [3] D. Mahoney, L. Casey, "Presentation on high-megawatt converter technology workshop," *Proceedings of the High Megawatt Converter Workshop*, Gaithersburg, MD, January 24, 2007.
- [4] D. Peters, "SiC power devices for industrial inverters," [http://siced.com/download/CY5063ab4aX1190ed29602XY353c/Abstract\\_Peters.pdf?ITServ=\\_CY11cb9072X1225bf7e84X30c6](http://siced.com/download/CY5063ab4aX1190ed29602XY353c/Abstract_Peters.pdf?ITServ=_CY11cb9072X1225bf7e84X30c6).

- [5] H. R. Chang, E. Hanna, A. V. Radun, "Demonstration of silicon carbide (SiC)-based motor drive," *Annual Conference of the IEEE Industrial Electronics Society*, 2003, pp. 1116-1121.
- [6] J. M. Hornberger, E. Cilio, B. McPherson, R. M. Schupbach, A. B. Lostetter, "A fully integrated 300°C, 4 kW, 3-Phase, SiC motor drive module," *IEEE Power Electronics Specialists Conference*, 2007, pp. 1048-1053.
- [7] A. Elasser, T.P. Chow, "Silicon carbide benefits and advantages for power electronics circuits and systems," *Proceeding of IEEE*, vol. 90, no. 6, pp. 969-986, June 2002.
- [8] A. R. Hefner, R. Singh, J. S. Lai, D. W. Berning, S. Bouche, and C. Chapuy, "SiC power diodes provide breakthrough performance for a wide range of applications," *IEEE Transactions on Power Electronics*, vol. 16, pp. 273-280, Mar. 2001.
- [9] L. M. Tolbert, H. Zhang, M. S. Chinthavali, B. Ozpineci, "SiC-based power converters for high temperature applications," *Materials Science Forum*, vols. 556-557, 2007, pp. 965-970.
- [10] H. Zhang, L. M. Tolbert, "Efficiency of SiC JFET-based inverters," *IEEE Conference on Industrial Electronics and Applications*, Xi'an, China, May 25-27, 2009, pp. 2056-2059.
- [11] D. Bergogne, H. Morel, D. Planson, D. Tournier, P. Bevilacqua, B. Allard, R. Meuret, S. Viellard, S. Rael, F. MeibodyTabar, "Towards an airborne high temperature SiC inverter," *IEEE Power Electronics Specialists Conference*, 2008, pp. 3178-3183.
- [12] H. Zhang, L. M. Tolbert, B. Ozpineci, "Impact of SiC Devices in Plug-in Hybrid Electric Vehicles," *IEEE Industry Applications Society Annual Meeting*, Edmonton, Canada, October 5-9, 2008.
- [13] C. Buttay, D. Planson, B. Allard, D. Bergogne, "State of the art of high temperature power electronics," *Microthrem*, Lodz, Poland, 2009.
- [14] M. A. Occhionero, R.W. Adams, and K. P. Fennessy, "A New Substrate for Electronic Packaging: Aluminum Silicon Carbide (AlSiC) Composites," *Proceedings of the Fourth Annual Portable by Design Conference*, Electronics Design, March 24-27, 1997, pp. 398-403.
- [15] E. S. Dettmer, B. M. Romenesko, H. K. Charles, Jr., B. G. Carkhuff, and D. J. Merrill, "Steady-State Thermal Conductivity Measurements of AlN and SiC Substrate Materials," *IEEE Transactions on Components, Hybrids, and Manufacturing Technology*, 12(4), December 1989, pp. 543-547.
- [16] T. R. Bloom, "The Reliability of AlN Power Hybrids Using Cu Thick Film Conductive," *Proceedings of the 40th Electronic Components and Technology Conference*, May 20-23, 1990, pp. 111-115.
- [17] F. Barlow and A. Elshabini, "High-Temperature High-Power Packaging Techniques for HEV Traction Applications", ORNL/TM-2006/515, published by UT-Battelle, LLC, Oak Ridge National Laboratory, Oak Ridge, Tennessee, Nov. 2006.
- [18] G. Harman, *Wire Bonding in Microelectronics: Materials, Processes, Reliability, and Yield*, Second Edition, McGraw-Hill Professional, June 1, 1997.
- [19] D. Olsen, K. James, "Effects of Ambient Atmosphere on Aluminum — Copper Wirebond Reliability," *IEEE Transactions on Hybrids and Manufacturing Technology*, vol. 7, no. 4, December 1984, pp. 357-362.
- [20] D. Palmer, "Hybrid Microcircuitry for 300°C Operation," *IEEE Transactions on Parts, Hybrids, and Packaging*, vol. 13, no. 3, September 1977, pp. 252-257.
- [21] J. T. Benoit, S. Chin, R. R. Grzybowski, L. Shun-Tien, R. Jain, P. McCluskey, T. Bloom, "Wire Bond Metallurgy for High Temperature Electronics," pp. 109-113 in *High Temperature Electronics Fourth International Conference, HITEC'98*, June 14-18, 1998.
- [22] J. T. Benoit, R. R. Grzybowski, D. B. Kerwin, "Evaluation of Aluminum Wire Bonds for High Temperature (2WC) Electronic Packaging," *Transactions of the Third International High Temperature Electronics Conference*, 1996, pp. III-17-23.