

2.32 THz quantum cascade laser frequency-locked to the harmonic of a microwave synthesizer source

Andriy A. Danylov,^{1,*} Alexander R. Light,¹ Jerry Waldman,¹
Neal R. Erickson,² Xifeng Qian,¹ and William D. Goodhue¹

¹Photonics Center, Department of Physics and Applied Physics, University of Massachusetts Lowell, Lowell, Massachusetts 01854, USA

²Department of Astronomy, University of Massachusetts Amherst, Amherst, Massachusetts 01003, USA

*Andriy_Danylov@uml.edu

Abstract: Frequency stabilization of a THz quantum cascade laser (QCL) to the harmonic of a microwave source has been accomplished using a Schottky diode waveguide mixer designed for harmonic mixing. The 2.32 THz, 1.0 milliwatt CW QCL is coupled into the signal port of the mixer and a 110 GHz signal, derived from a harmonic of a microwave synthesizer, is coupled into the IF port. The difference frequency between the 21st harmonic of 110 GHz and the QCL is used in a discriminator to adjust the QCL bias current to stabilize the frequency. The short-term frequency jitter is reduced from 550 kHz to 4.5 kHz (FWHM) and the long-term frequency drift is eliminated. This performance is compared to that of several other THz QCL frequency stabilization techniques.

©2012 Optical Society of America

OCIS codes: (140.5965) Semiconductor lasers, quantum cascade; (140.3425) Laser stabilization; (300.3700) Linewidth; (190.2620) Harmonic generation and mixing.

References and links

1. A. L. Betz, R. T. Boreiko, B. S. Williams, S. Kumar, Q. Hu, and J. L. Reno, "Frequency and phase-lock control of a 3 THz quantum cascade laser." *Opt. Lett.* **30**(14), 1837–1839 (2005).
2. A. A. Danylov, T. M. Goyette, J. Waldman, M. J. Coulombe, A. J. Gatesman, R. H. Giles, W. D. Goodhue, X. Qian, and W. E. Nixon, "Frequency stabilization of a single mode terahertz quantum cascade laser to the kilohertz level," *Opt. Express* **17**(9), 7525–7532 (2009).
3. D. Rabanus, U. U. Graf, M. Philipp, O. Ricken, J. Stutzki, B. Vowinkel, M. C. Wiedner, C. Walther, M. Fischer, and J. Faist, "Phase locking of a 1.5 Terahertz quantum cascade laser and use as a local oscillator in a heterodyne HEB receiver," *Opt. Express* **17**(3), 1159–1168 (2009).
4. P. Khosropanah, A. Baryshev, W. Zhang, W. Jellema, J. N. Hovenier, J. R. Gao, T. M. Klapwijk, D. G. Paveliev, B. S. Williams, S. Kumar, Q. Hu, J. L. Reno, B. Klein, and J. L. Hesler, "Phase Locking of a 2.7 THz quantum cascade laser to a microwave reference," *Opt. Lett.* **34**(19), 2958–2960 (2009).
5. S. Barbieri, P. Gellie, G. Santarelli, L. Ding, W. Mainault, C. Sirtori, R. Colombelli, H. Beere, and D. Ritchie, "Phase-locking of a 2.7-THz quantum cascade laser to a mode-locked erbium-doped fibre laser," *Nat. Photonics* **4**(9), 636–640 (2010).
6. M. Ravano, C. Manquest, C. Sirtori, S. Barbieri, G. Santarelli, K. Blary, J.-F. Lampin, S. P. Khanna, and E. H. Linfield, "Phase-locking of a 2.5 THz quantum cascade laser to a frequency comb using a GaAs photomixer," *Opt. Lett.* **36**(20), 3969–3971 (2011).
7. H. Richter, S. G. Pavlov, A. D. Semenov, L. Mahler, A. Tredicucci, H. E. Beere, D. A. Ritchie, and H.-W. Hübers, "Submegahertz frequency stabilization of a terahertz quantum cascade laser to a molecular absorption line," *Appl. Phys. Lett.* **96**(7), 071112 (2010).
8. Y. Ren, J. N. Hovenier, M. Cui, D. J. Hayton, J. R. Gao, T. M. Klapwijk, S. C. Shi, T.-Y. Kao, Q. Hu, and J. L. Reno, "Frequency locking of single-mode 3.5-THz quantum cascade lasers using a gas cell," *Appl. Phys. Lett.* **100**(4), 041111 (2012).
9. Virginia Diodes, Inc., Charlottesville, VA.
10. T. Yasui, R. Nakamura, K. Kawamoto, A. Ihara, Y. Fujimoto, S. Yokoyama, H. Inaba, K. Minoshima, T. Nagatsuma, and T. Araki, "Real-time monitoring of continuous-wave terahertz radiation using a fiber-based, terahertz-comb-referenced spectrum analyzer," *Opt. Express* **17**(19), 17034–17043 (2009).

11. X. Qian, N. Chandrayan, S. Vangala, W. Goodhue, A. Danylov, J. Waldman, R. Giles, and W. E. Nixon, "One-half milliwatt 2.33 THz CW QCL operating at 77 K," *Proc. SPIE* **8261**, 826121 (2012).
 12. A. A. Danylov, J. Waldman, T. M. Goyette, A. R. Light, R. H. Giles, X. Qian, N. Chandrayan, W. D. Goodhue, and W. E. Nixon, "Long-term frequency and amplitude stability of a solid-nitrogen-cooled, continuous wave THz quantum cascade laser," *Proc. SPIE* **8261**, 82610D-1, 82610D-5 (2012).
 13. M. S. Vitiello, G. Scamarcio, V. Spagnolo, S. S. Dhillon, and C. Sirtori, "Terahertz quantum cascade lasers with large wall-plug efficiency," *Appl. Phys. Lett.* **90**(19), 191115 (2007).
 14. A. A. Danylov, J. Waldman, T. M. Goyette, A. J. Gatesman, R. H. Giles, K. J. Linden, W. R. Neal, W. E. Nixon, M. C. Wanke, and J. L. Reno, "Transformation of the multimode terahertz quantum cascade laser beam into a Gaussian, using a hollow dielectric waveguide," *Appl. Opt.* **46**(22), 5051–5055 (2007).
 15. Low Noise Quantum Cascade Laser Driver QCL1500, Wavelength Electronics Inc.
 16. N. R. Erickson, "A Schottky-Diode Balanced Mixer for 1.5 THz," *ISSIT Groningen*, 221–223 (2008).
 17. S. Martin, B. Nakamura, A. Fung, P. Smith, J. Bruston, A. Maestrini, F. Maiwald, P. Siegel, E. Schlecht, and I. Mehdi, "Fabrication of 200 to 2700 GHz multiplier devices using GaAs and metal membranes," in *Proceedings of IEEE MTT-S Int. Microw. Symp. Dig.*, Piscataway, NJ, (IEEE 2001), pp. 1641–1644.
 18. N. R. Erickson and T. M. Goyette, "1.5 THz low noise Schottky-diode mixers." http://www.softa.usra.edu/Science/workshops/asilomar_docs/Poster_3.7_Erickson.pdf.
 19. A. A. Danylov, J. Waldman, T. M. Goyette, A. J. Gatesman, R. H. Giles, J. Li, W. D. Goodhue, K. J. Linden, and W. E. Nixon, "Terahertz sideband-tuned quantum cascade laser radiation," *Opt. Express* **16**(8), 5171–5180 (2008).
-

1. Introduction

Frequency and phase-locking of continuous wave (CW) THz QCLs has been an active area of research, following the initial demonstration of Betz, et al [1]. in 2005. Three separate approaches have been used with varying degrees of success:

1. Stabilization against a more stable THz source of comparable frequency [1–4].
2. Stabilization to one tooth of a frequency comb of a mode-locked femtosecond laser [5,6].
3. Stabilization to the peak of a molecular absorption line [7,8].

To place the present work in context, the features and limitations of these methods are reviewed.

Betz [1] locked a 3 THz QCL to a far-infrared gas laser line, using the intermediate frequency (IF) signal generated in a corner-reflector-mounted GaAs Schottky diode mixer and a feedback loop to adjust the QCL current. The measured 65 kHz full-width-half-maximum (FWHM) linewidth of the IF signal was much greater than the gas laser linewidth, hence the QCL was frequency-locked to 65 kHz. A similar approach, with improved signal-to-noise, was later used by Danylov [2], who obtained an IF FWHM of 3-4 kHz, which was narrower than the 20-30 kHz frequency jitter of the gas laser. Since the locking circuit stabilizes the IF, it can track the QCL frequency to the reference, i.e, the frequency of the locked source is only as stable as the reference. Rabanus [3], employed a much more portable and stable reference to phase-lock a 1.5 THz QCL laser. They used a commercial 1.499 THz, solid state multiplier signal [9] to drive a superconducting hot-electron bolometer (HEB) mixer and used the 1.2 GHz IF signal to phase-lock the QCL. While technically interesting, the requirement of a THz solid state multiplier source to lock a QCL at approximately the same frequency only has value if the greater QCL power can be leveraged for some application. Khosropanah [4] used a semiconductor superlattice device to generate 1-2 pW of THz power at the 15th harmonic of a 182 GHz microwave-synthesizer-derived source to phase-lock a 2.7 THz QCL. In both [3] and [4] a superconducting hot electron bolometer (HEB) mixer was required to generate the IF signal required for locking.

Barbieri, et. al. [5] phase-locked a 2.7 THz QCL to one of the components of the frequency comb of a mode-locked femtosecond fiber laser. They used the method of electro-optic sampling of the second harmonic of the 1.55 micron laser, modulated by the focused QCL beam in a ZnTe crystal, which was first employed to monitor CW millimeter wave and THz radiation by Yasui et. al [10]. Effectively, the 2.7 THz radiation was upconverted to the

visible, producing upper and lower sideband replicas of the comb. A component of the replica mixed with a tooth of the comb to produce a signal in the MHz region, which was used for phase-locking. While the IR/VIS source and detection system add additional equipment to the THz QCL hardware, nearly the entire power spectrum of the QCL was phase-locked with a beat-note S/N of 80 dB in a 1 Hz resolution bandwidth. The estimated drift rate of the tooth, ~kHz/s, can be virtually eliminated by locking the repetition rate of the fiber laser with an ultra-stable RF source, so the frequency comb technique can potentially stabilize the THz QCL frequency to a drift rate of a fraction of 1 Hz/s [10]. In Ref [6], the same group phase locked the QCL to a frequency comb by generating the IF beat signal in a GaAs photomixer.

Frequency-locking of a 2.55 THz QCL to a molecular transition line center in methanol was reported by Richter and associates [7] in 2010, and recently at 3.5 THz by Ren, et. al. [8], who also used a methanol line. Ren reduced the laser's frequency fluctuation to 18 kHz FWHM by locking, compared to 1 MHz unlocked. Since THz molecular linewidths are at least in the MHz range due to Doppler broadening, and probably higher in the gas cell in order to obtain a reasonable absorption signal, achieving a lock in the 20 kHz range implies stabilizing to within ~0.1% of the line center. Hence, a very sensitive and relatively fast THz detector is required to produce a noise-free error signal for the feedback circuit. For this reason, both teams employed liquid-helium-cooled detectors. Locking to a molecular transition has other limitations; the laser cannot be locked to an arbitrary frequency, a strong, well-isolated absorption line is required, the laser must be frequency modulated, and phase locking is not possible.

The THz frequency-locking technique described in Section 2.4 is most comparable to the first method discussed above, but greatly simplifies the required hardware and eliminates the need for an HEB mixer. The key device is the room temperature harmonic mixer, which generates both the reference frequency (the THz harmonic), and the detector signal (the IF output) that is used for locking.

2. Experimental setup

Efforts have been focused on obtaining higher temperature CW operation, stable frequency QCL performance, and sufficient output power to drive state-of-the-art Schottky diode mixers. The operating temperature of CW THz QCLs has increased [11] making it possible to employ solid nitrogen (SN₂) as the cryogen [12].

2.1 A simple, cost-effective THz QCL cryogen

The QCL dewar chamber contains LN₂, which is solidified by pumping down to pressures of a few torr. After approximately one hour, a dynamic equilibrium between the sublimation and vapor pumping processes is reached inside the dewar at an equilibrium temperature measured at the QCL mount of 47-48 K, when the laser is not biased, and 56-61 K when 5 W of electrical power is dissipated in the laser operating in the CW mode. The dewar is continuously pumped with a roughing pump and the steady-state temperature is maintained until the SN₂ is nearly completely sublimed. This allowed continuous operation of the 2.32 THz QCL for 20 hours with 5 W of DC power consumption [12].

2.2 The continuous wave THz quantum cascade laser

Figure 1(a) is a plot of the output power versus temperature of a 2.32 THz QCL grown at the UMass Photonics Center, which continues to radiate over 2 mW CW at 60 K from a single facet. The GaAs wells and GaAlAs barriers were grown based on the structure published by M. Vitiello et al [13]. The bound-to-continuum, semi-insulating surface plasmon waveguide structure was used in the QCL and it had a 3 mm cavity length and a 250 μm waveguide ridge width. It was mounted on the bottom cold plate of the solid-nitrogen inner dewar to maintain the ambient device temperature at about 58 K. A hollow dielectric Pyrex tube of 18 mm length and 1.8 mm inner diameter, positioned directly in front of the laser, was used to

significantly improve the laser radiation spatial mode quality to a near-Gaussian beam profile [14]. 2-D scans measured at distance of 110 mm from the exit of the waveguide, shown in Figs. 2(a) and 2(b), illustrate the spatial coherence improvement. The waveguide efficiency was -3 dB. The QCL was operated CW at 58 K when biased at ≈ 800 mA and 4.5 V using a state-of-the-art current controller [15].

The laser spectrum at 58 K, measured with a 4 GHz resolution FTIR is displayed in Fig. 1(b), for two DC bias conditions. The CW laser emitted radiation primarily in a single-longitudinal mode (SLM) up to 4.5 V, and multi-mode at higher voltages.

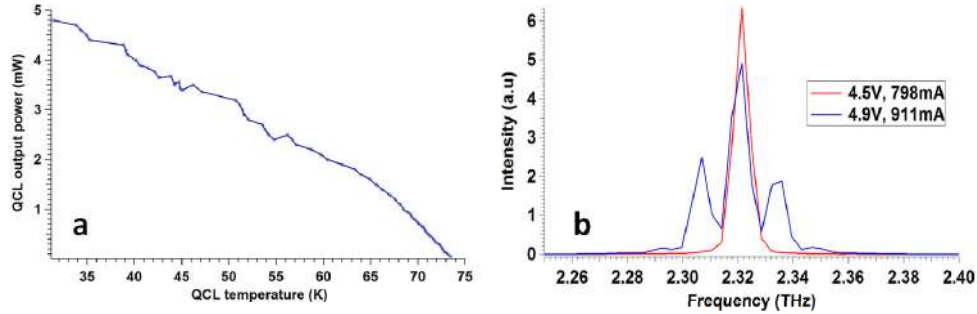

Fig. 1. (a) 2.32 THz QCL output power as a function of the QCL mounting plate temperature. (b) Spectral intensity of the 2.32 THz QCL in CW mode at different applied voltages at solid nitrogen temperature (56-59 K).

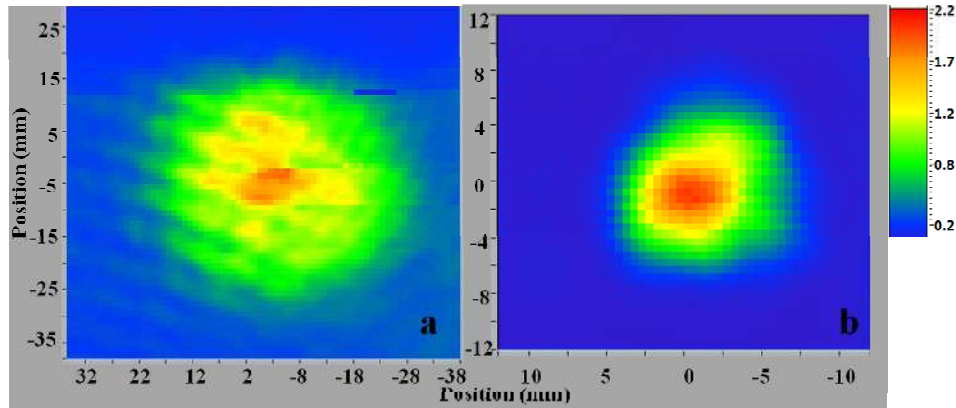

Fig. 2. 2-D mode profile of the 2.32 THz QCL without (a) and with (b) a hollow dielectric waveguide measured at distance of 110 mm from the exit of the waveguide.

2.3 The terahertz balanced mixer

In 2008 Erickson built and demonstrated the first THz Schottky diode balanced mixer [16] using a THz monolithic microwave integrated circuit (MMIC) chip designed at UMass and fabricated at JPL [17]. The proof-of-principle measurements were performed using a CO_2 pumped methanol laser line at 1.562 THz as the local oscillator. Figures 3(a) and 3(b) show the layout of the THz mixer MMIC. For use as a mixer-downconverter, the free-space-propagating LO and RF signals are coupled into opposite sides of the waveguide block by integral diagonal feed horns, and the intermediate frequency (IF) signal is coupled out the IF port.

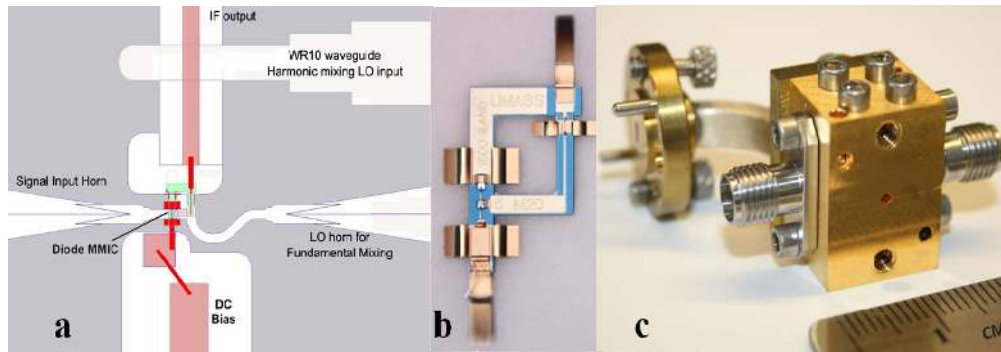

Fig. 3. (a) Schematic diagram of the balanced mixer showing the WR10 waveguide that is used as the LO input as well as the LO feed horn that is not used for harmonic mixing. The horn on the left side is used for the QCL signal input. (b) Photograph of the device (taken from Ref. 18). Green areas are the GaAs substrate and gold areas are metal on the MMIC chip. (c) Photograph of the mixer block with the W-band waveguide input.

The THz balanced mixer has been shown to provide superior performance to corner-cube-mounted, whisker-contacted, Schottky diodes, both as downconverters and sideband generators [18] when used as conventional fundamental mixers. Recent upconversion results produced a record 45 microwatts of sideband power (both sidebands) at the output port for 1.5 mW of laser drive power and implied only a 15 dB conversion loss.

The mixer used in the frequency-locking experiment was modified for use as a harmonic mixer by adding a separate W-band waveguide port for injecting a millimeter wave local oscillator signal into the internal IF microstrip line, leaving the coaxial IF port free for coupling out the 3 GHz IF beat signal between a harmonic of the millimeter wave and laser frequencies. Figure 3(a) shows the internal details while Fig. 3(c) is a photo of the modified mixer block. One of the mixer's diodes was damaged during initial tests, thus eliminating the features of a balanced mixer, one of which is the rejection of AM noise of the LO source. This noise is believed to reduce the S/N by ~10 dB.

The bandwidth of the 1.5 THz mixer was found to extend well beyond its design band of 1.2-1.7 THz. Testing it using a CO₂ pumped methanol laser line at 2.310 THz demonstrated good harmonic mixer response, which motivated its use with the 2.32 THz QCL.

2.4 Frequency locking optics and electronics

A schematic of the experimental setup is shown in Fig. 4. The radiation from one facet of the CW 2.321 THz QCL, operated in a single longitudinal mode was focused into the mixer with a 9 inch focal length spherical mirror positioned 15° off-axis. An amplifier/tripler/amplifier chain was driven by an Agilent synthesizer (M1), model E8257D to produce an output at 110.38 GHz with 8 mW of power. This signal was coupled into the mixer's WR 10 waveguide port, and its 21st harmonic created an effective LO at approximately 2.318 THz. With a bias current of 1 mA applied to the mixer, the mixer's response was 600-800 mV to the microwave signal, and 1 mV to the QCL power. Harmonic mixers typically have very high conversion loss, rising rapidly with harmonic number, and this is why we used a high LO frequency. In this case the conversion loss is ~100-110 dB, but this is still adequate to produce a 25 dB S/N in a narrow bandwidth.

To generate a frequency discriminator signal, the IF signal is amplified by 70 dB and downconverted to 21.4 MHz using a microwave mixer and synthesizer (M2). The 21.4 MHz signal is amplified by 70 dB and passed through a 100 kHz wide RF bandpass filter centered at 21.4 MHz. The synthesizer frequency is sinusoidally FM modulated at 89 kHz with a modulation depth of 100 kHz, and the modulation frequency is used as a reference frequency for the lock-in amplifier (LIA), whose input is the RF-rectified 21.4 MHz signal. The lock-in

output at the reference frequency is proportional to the first derivative of the bandpass spectrum and thus provides a basis for locking the laser frequency to the harmonic of the microwave reference. The lock-in output is input to a proportional/integral (PI) feedback circuit with independent and adjustable gain controls. A 1 kHz bandwidth of the feedback loop was determined by the optimized LIA time constant of 1 ms. The output of the PI circuit is used as the error-correcting signal.

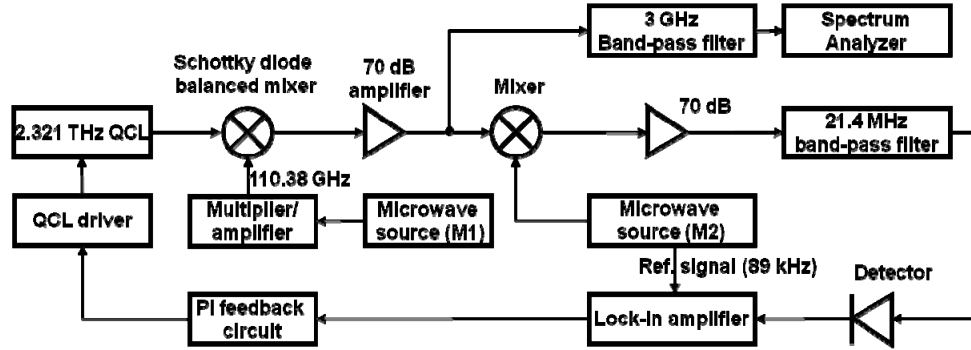

Fig. 4. Circuit configuration used in frequency locking the QCL to the 21st harmonic of the microwave source (M1). The modulated microwave source (M2) and 21.4 MHz bandpass filter provided an error signal that stabilized the intermediate frequency (IF) and locked the QCL to the microwave reference source.

3. QCL frequency stability results

The proportional and integral parts of the feedback circuit ensure the spectral purity and the long-term stability of the QCL, respectively. The long-term 2.321 THz QCL stability results are shown in Fig. 5(a) where data were obtained from successive spectrum analyzer scans. For each scan the frequency was estimated from the centroid of the beat signal. The red curve's FWHM frequency distribution of 550 kHz, estimated from RMS frequency fluctuations of 230 kHz using the fact that for Gaussian distributions, $\text{FWHM} = 2.35\text{RMS}$, which represents the free-running QCL stability over 30 minutes, is significantly larger than the one of the blue line which represents the locked laser's frequency stability. The blue line reveals a frequency distribution of 4.5 kHz (FWHM) during a 3 hour time frame (Fig. 5(b)) with no discernible frequency drift, which was obtained from RMS data of 1.9 kHz. The data for Fig. 5(b) were obtained with a resolution bandwidth of 1 kHz. A resolution bandwidth of 30 kHz was used to record free-running QCL data.

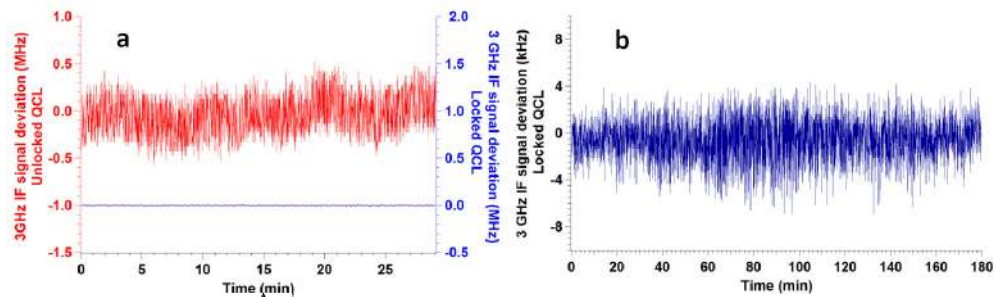

Fig. 5. (a) Long-term frequency fluctuations of the 3 GHz beat signal recorded during 30-min time interval of the free-running (red curve) and locked (blue curve) QCL. (b) Long-term (3 hours) frequency fluctuations of the 3 GHz beat signal recorded when the laser was stabilized.

The largest correction signal that the integrator can produce is 15 V. By the end of 3 hour run time, the error signal monitor indicated only 3 V. Thus, the frequency locking time could have been extended by several hours. These results were achieved with an integrator

bandwidth of approximately 1 Hz and a proportional circuit bandwidth of 1 kHz, determined by the LIA time constant.

Figure 6 shows the time averaged beat note between frequencies of the stabilized laser and 21st harmonic of the microwave source, which was recorded by averaging over 100 sweeps using a resolution bandwidth of 1 kHz.

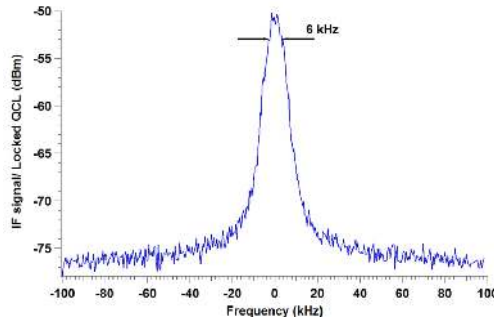

Fig. 6. Frequency spectra of the 3 GHz beat note recorded from the spectrum analyzer (resolution bandwidth of 1 kHz) under locked conditions with 400 ms scan time (the spectrum was averaged over 100 scans).

The width of 6 kHz is a combination of the width due to fluctuations (4.5 kHz FWHM), and the intrinsic linewidth due to system noise. In all measurements reported in the paper, the observed frequency linewidth was dominated by frequency jitter and drifts caused by temperature and current fluctuations. The electronic feedback was used to increase QCL frequency stability; however, there is another very strong frequency destabilizing mechanism – optical feedback, where part of the QCL radiation is fed back to the laser by optical elements (mirror, input waveguide of the mixer). It can cause frequency instability of a few megahertz, which needs to be additionally suppressed. To reduce its effect an optical isolator can be employed, but was not available at the time of the experiment. The simplest isolator would be an attenuator but that would lead to a reduction in S/N ratio and QCL frequency stability. A small optical misalignment of the system was used to reduce feedback and make the free-running laser frequency stable within 1 MHz without significantly reducing the 3 GHz S/N ratio.

4. Conclusion

This paper provides the first report of direct frequency locking of a THz QCL with a harmonic mixer, a technique that eliminates much of the hardware requirements of earlier work, including LHe-cooled detectors, THz frequency reference sources, or alternatively, mode-locked femtosecond lasers and associated frequency-shifting components. The superior performance of GaAs Schottky membrane diodes incorporated with monolithic RF circuitry, compared to earlier generation THz Schottky mixers, enabled this work. Substantial further improvement in S/N is anticipated with a balanced mixer designed to match the QCL frequency, approximately 5 dB from better coupling and 10 dB from AM noise reduction. The success with the mixer/QCL combination suggests other applications including compact local oscillators and tunable THz radiation by sideband generation at considerably higher power levels than previously obtained with a corner-cube mixer [19].

Acknowledgments

We thank I. Mehdi of JPL for providing the devices used in the mixer and R. Grosslein for machining the mixer block. T. Goyette and M. Coulombe provided valuable assistance in the design of the frequency stabilization circuit.