

3.9 GHZ SUPERCONDUCTING ACCELERATING 9-CELL CAVITY VERTICAL TEST RESULTS

Timergali Khabiboulline, Charles Cooper, Nandhini Dhanaraj, Helen Edwards, Mike Foley, Elvin Harms, Donald Mitchell, Allan Rowe, Nikolay Solyak. FNAL, Batavia, IL 60510, U.S.A
 Wolf-Dietrich Moeller, DESY, Notkestrasse 85, Hamburg, Germany.

Abstract

The 3rd harmonic 3.9GHz accelerating cavity was proposed to improve the beam performance of the FLASH (TTF/DESY) facility [1]. In the frame of a collaborative agreement, Fermilab will provide the DESY with a cryomodule containing a string of four cavities. In addition, a second cryomodule with one cavity will be fabricated for installation in the Fermilab photo-injector, which will be upgraded for the ILC accelerator test facility. The first 9-cell Nb cavities were tested in a vertical setup and they didn't reach the designed accelerating gradient [2]. The main problem was a multipactor in the HOM couplers, which lead to overheating and quenching of the HOM couplers. New HOM couplers with improved design are integrated in the next 9-cell cavities. In this paper we present all results of the vertical tests.

INTRODUCTION

The 3rd harmonic nine-cell 3.9 GHz cavity was proposed to linearize the energy distribution along the bunch before the bunch compressor. Four of such cavities will operate at gradient 14 MV/m in the TM010 mode and will be located downstream of the first TTF cryomodule. Tests of the 3-cell prototype demonstrated accelerating gradient of ~23 MV/m limited by thermal breakdown quench. After these successful tests, we started building the final design: 9-cell cavities with HOM couplers and ports for the main coupler and the pick-up antenna. The vertical tests of the first two cavities showed the multipacting (MP) problems in the HOM coupler. [1]. Subsequent simulation studies confirmed and explained test results. Based on these studies, we proposed few new designs of the HOM coupler to eliminate the MP problem. The simplest solution was to trim the tip of the HOM coupler antenna to reduce the electromagnetic field. This solution was applied to the cavities already built. Cavity #3 was re-tested after that modification and showed the ultimate accelerating gradient for this design. We now have four cavities with modified HOM couplers: two of them were tested successfully and the other two are being prepared for testing. Four other cavities with completely new HOM coupler are under construction and will be ready soon.

PREVIOUS TEST RESULTS

Analysis of the thermal breakdown problems observed in cavity #2 and #3 and the multipactor analysis clearly demonstrated that the MP problem is in the HOM couplers. MP conditions exist only in some particular

ranges of the electromagnetic field. In the initial design of the cavity, the simulations show two danger zones: the first one at a level of ~1.5 MV/m is narrow. The second zone is much wider and stronger and starts at an accelerating field of 12 MV/m, just below the operating level at 14 MV/m [2]

The first MP zone was the major problem in vertical test of the cavity #2. The attempts to process the MP by using long pulses or a CW regime caused damage of both HOM couplers due to the large RF power dissipation in the HOM antenna. Cavity #3 with the same design showed better performances. The low gradient MP zone was processed pretty fast, but the MP in the second zone was much stronger and we could not reach gradients higher than 12 MV/m (Figure 1). Thermometry data always showed heating of the HOM coupler when MP took place [3].

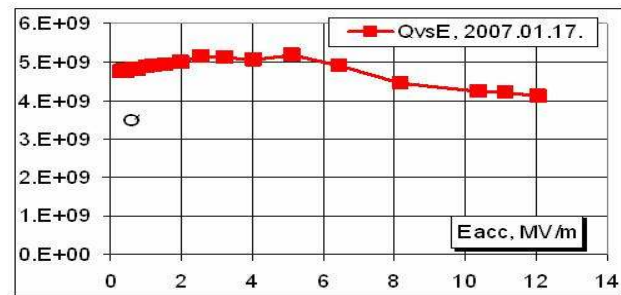

Figure 1: Thermal breakdown in the HOM couplers of the cavity #3 limits accelerating field at ~12 MV/m.

Decreasing the field in the HOMs is one of the possible solutions to eliminate the multipactor. Since the end-assemblies for the next three cavities (#4, #5 and #6) were already welded, the easiest solution was to trim the tip of the HOM coupler formtile. The trimming reduces the electric fields in the HOM thanks to two main factors:

- Slightly reduced RF coupling at 3.9 GHz.
- Shifting of the second HOM resonance frequency away from the operating frequency by a factor of two.

HFSS calculations show a decrease of the field in the HOM by factor of 2.5 after tips trimming (Figure.2) [4]

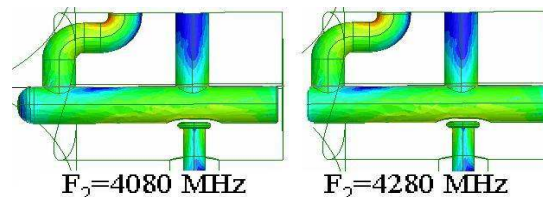

Figure 2: Surface H-fields and resonance frequency of the HOM before (left) and after trimming of the tip.

The trimming of the HOM tips was tested first with a spare HOM. The workmanship was inspected visually and carefully and after achieving acceptable results, the trimming technique was implemented to two pairs of the end assemblies with HOM couplers (Figure 3). Then the assemblies were shipped to JLAB for welding with the rest of cavity #4. After successful tests of cavity #4, we made the same modifications to the end-assemblies of cavities No.5 -6 and trim the HOM antennas on the already built and tested cavity #3.



Figure 3: HOM formtile tip after trimming.

COLD TESTS OF THE CAVITY #4

The welded cavity #4 was shipped to Fermilab for further treatment. After the standard sequence of treatments such as mechanical inspection, RF tuning, Buffered Chemical Polishing (BCP), 800 °C baking and High Pressure Rinsing (HPR) the cavity was installed in the vertical cryostat for cold tests.

The first test took place on April 6th, 2007. Despite a small He leak, a residual surface resistance of 20 nΩ and an accelerating field of 20 MV/m were reached. Thermal breakdowns were observed in both HOM couplers, presumably due to the He leak. Subsequently the leak in the main coupler port flange vacuum seal was eliminated, the cavity was “baked” at 150 °C and tested again on April 13th. The cavity reached an accelerating field of 22 MV/m limited by x-rays emission. Following additional HPR, the cavity was tested again on April 21st, reaching an accelerating field of 23 MV/m and a quality factor of $3 \cdot 10^9$ limited by a quench in the cavity. There was no evidence of quench in the HOM couplers. Results of the Q vs. T measurements are shown in Figure 4.

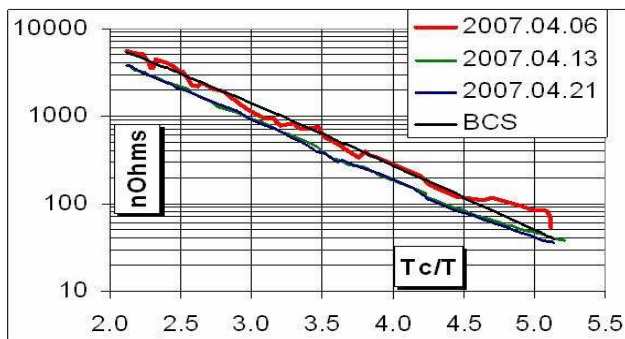

Figure 4: Cavity #4: Results of Q vs. T measurement at low field level.

Then HOM antennas cleaned by 5' BCP were installed and notch frequencies of both antennas were tuned (Figure 5). Qext of the HOMs at operating frequency of 3.9GHz were about $2 \cdot 10^{12}$.

The last test of cavity #4 with the installed HOM antennas was done on April 26th. An accelerating field of 23 MV/m was reached in the pulsed regime limited by a quench in the cavity (Figure 6).

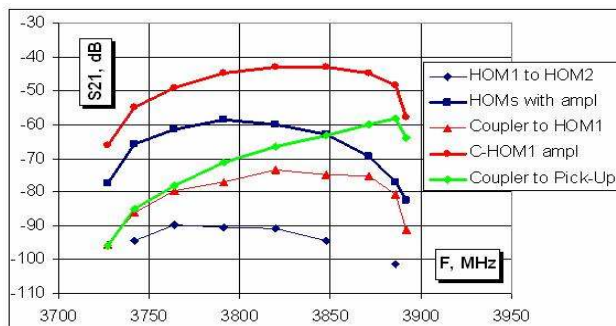

Figure 5: Cavity #4 with HOM antennas installed. Transition S21 after notch frequencies tuning.

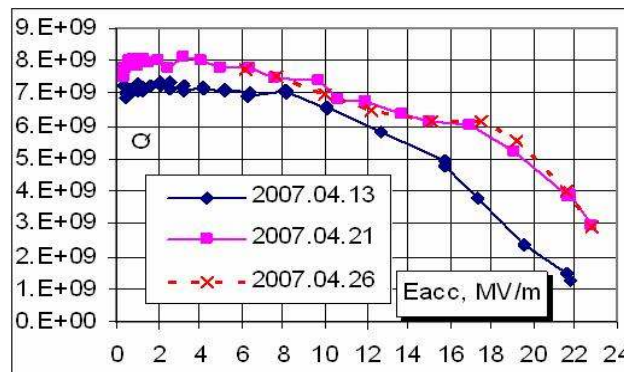

Figure 6: Cavity #4 vertical test results.

Test in CW regime

In pulsed regime, the accelerating field of ~22 MV/m, was limited by x-rays. In CW regime we reached 12 MV/m, limited by quench in the HOM antenna tip (Fig.7).

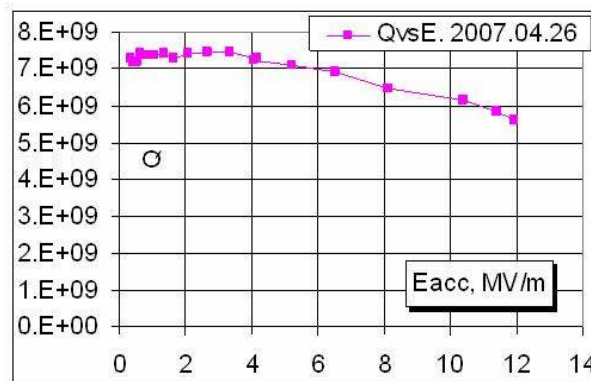

Figure 7: CW measurements of the cavity #4 with HOM antennas installed.

The power extracted by the HOM coupler was very low and external Q of the HOM coupler exceeded 10^{12} . This demonstrates good stability of the notch frequency.

The broadband HOM coupler antenna designed specifically for this application has a good transmission up to 12 MHz (Figure 8). Sapphire ceramic window and high RRR Nb antenna tip allows us to reach 12 MV/m in CW operation. Since we fear that a $5\mu\text{m}$ material removal by BCP may not be sufficient, we plan to use $20\mu\text{m}$ pre-etched Nb tips for the production of the new HOM antennas.

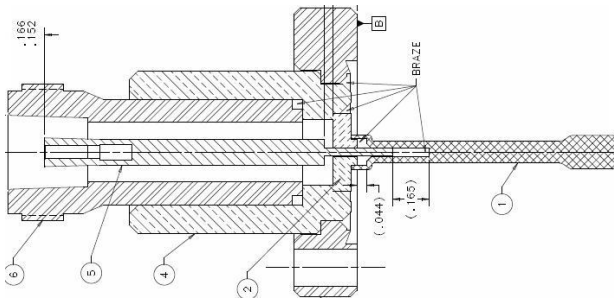

Figure 8: HOM antenna with sapphire window and Nb tip.

COLD TESTS OF THE CAVITY #3 AFTER TRIMMING OF THE HOM TIPS

After the successful test of cavity #4, it was decided to trim off the HOM tips of the cavity #3. Mechanically, this solution was complicated by the limited access to the tips and the possibility of contamination of the cavity.

After a first HPR, light BCP and then a standard 2 hours HPR, the cavity was installed for a vertical cold test. In the first test, a ~ 24 MV/m accelerating field was reached limited by x-rays. For measurements at $\pi/9$ mode, the quench was reached in the middle cell, while at $8\pi/9$ mode, the quench was reached in the bottom end-cell. In both modes the surface field was approximately 120 mT (Figure 9).

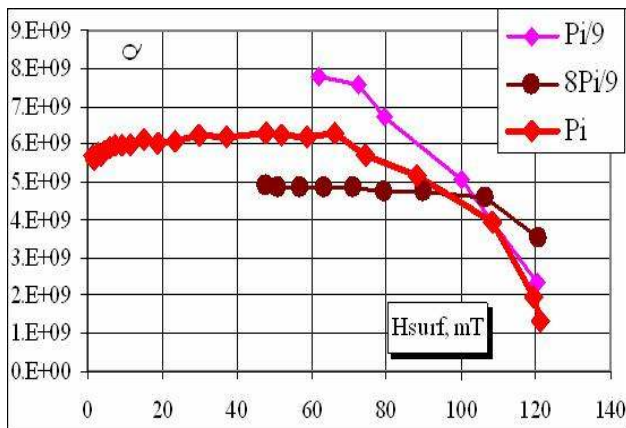

Figure 9: Cavity #3 vertical test 2007.05.11.

A fast thermometry system developed at Fermilab [3] was a very useful instrument for the investigations of the

breakdown problems in the HOM couplers and cavity (Figure 10).

Detectable x-ray was observed at the operating acceleration level of ~ 14 MV/m. After additional HPR, the cavity was re-tested again on May 22nd, reaching the accelerating field of ~ 22 MV/m with a lower level of x-rays.

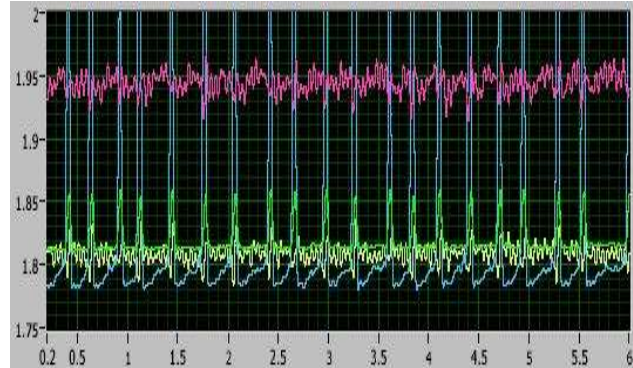

Figure 10: Fast thermometry shows quench in the bottom cell in “8Pi/9” modes at 120 mT surface cell.

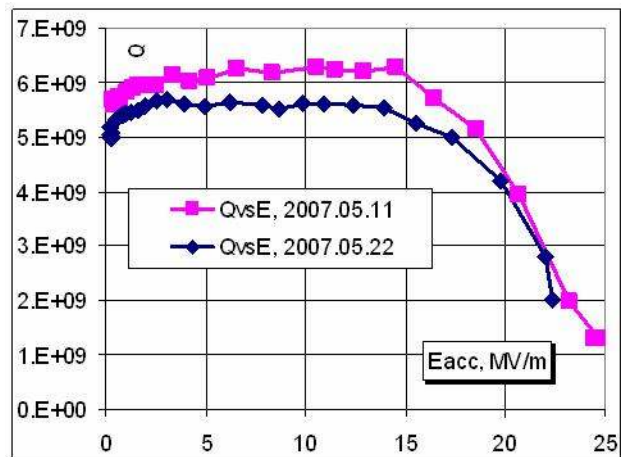

Figure 11: Cavity #3 vertical test results after trimming of the HOM coupler tips.

ACKNOWLEDGEMENTS

The authors wish to thank Dave Burk, Tug Arkan, Harry Carter and Eugeny Borissov for help and useful discussions and John DeFord for providing the code and help with MP simulations.

REFERENCES

- [1] N.Solyak, et.al, Production and test results of SC 3.9 GHz accelerating Cavity at Fermilab, ASC2006.
- [2] I.Gonin, et.al, Multipactor simulations in superconducting cavities, this conference WEPMN093.
- [3] D.Orris, et.al, Fast Thermometry for Superconducting RF Cavity Testing, This conference WEPMN105.
- [4] T.Khabiboulline et.al, new HOM coupler designs for 3.9 GHz superconducting cavities at FERMILAB” WEPMN098, This conference.