



Lawrence Berkeley Laboratory

UNIVERSITY OF CALIFORNIA

Physics, Computer Science &
Mathematics Division

RECEIVED
LAWRENCE
BERKELEY LABORATORY

JAN 11 1983

Submitted to Physical Review Letters

LIBRARY AND
DOCUMENTS SECTION

3 mm ANISOTROPY MEASUREMENT: ON THE QUADRUPOLE
COMPONENT IN THE COSMIC BACKGROUND RADIATION

Philip M. Lubin, Gerald L. Epstein, and
George F. Smoot

November 1982

TWO-WEEK LOAN COPY

*This is a Library Circulating Copy
which may be borrowed for two weeks.
For a personal retention copy, call
Tech. Info. Division, Ext. 6782.*

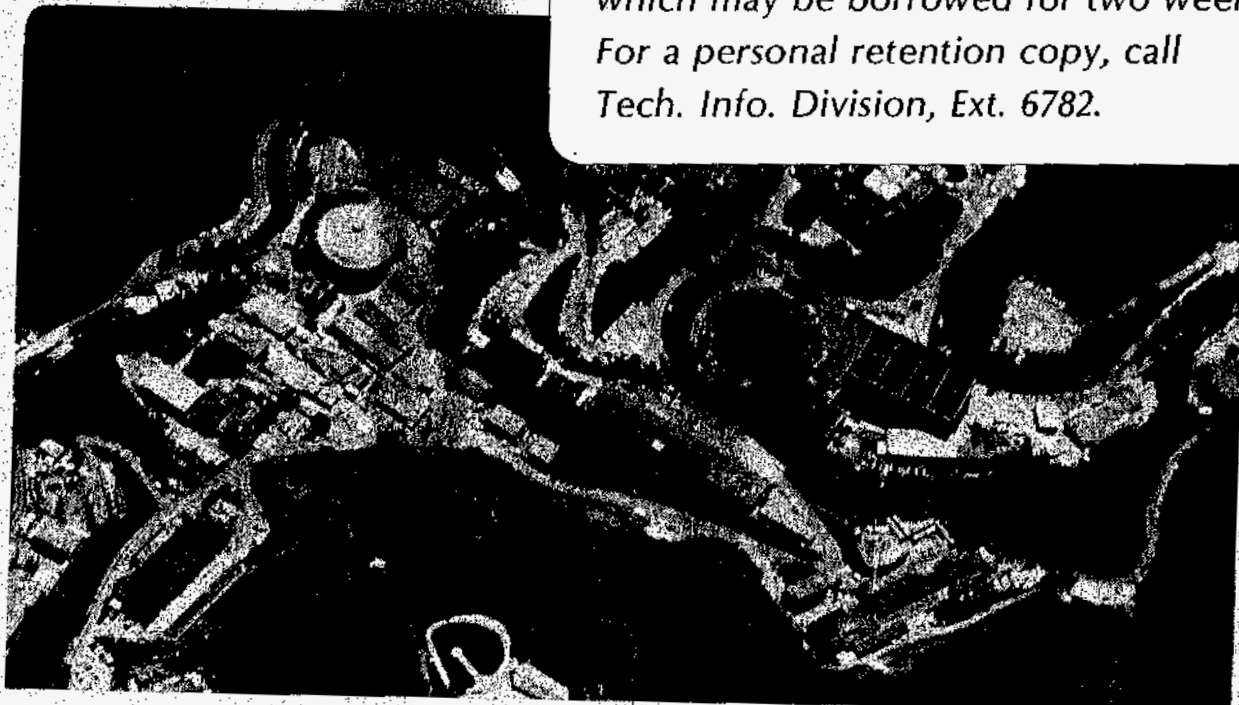

*LBL-15223
cd*

3 mm Anisotropy Measurement: On the Quadrupole Component
in the Cosmic Background Radiation

Philip M. Lubin^(a)

Space Sciences Laboratory and Lawrence Berkeley Laboratory
University of California, Berkeley, CA. 94720 and
Joseph Henry Laboratories, Physics Department
Princeton University, Princeton, N. J. 08544

and

Gerald L. Epstein^(b) and George F. Smoot

Space Sciences Laboratory and Lawrence Berkeley Laboratory
University of California, Berkeley, CA. 94720

ABSTRACT

We have mapped the large-scale anisotropy in the cosmic background radiation at 3 mm wavelength using a liquid-helium-cooled balloon-borne radiometer sensitive enough to detect the dipole in one gondola rotation (1 minute). Statistical errors on the dipole and quadrupole components are below 0.1 mK with less than 0.1 mK galactic contribution. We find a dipole consistent with previous measurements but disagree with recent quadrupole reports. The measurement is also useful in searching for spectral distortions.

PACS: 98.70 Vc, 98.80 Bp

This work was supported by the Director, Office of Energy Research, Office of High Energy and Nuclear Physics, Division of High Energy Physics of the U.S. Department of Energy under Contract No. DE-AC03-76SF00098.

The large-scale anisotropy in the cosmic background radiation is one of the best probes available for studying the global properties of the universe. To date the only well established^{1,2,3} deviation from a strictly isotropic distribution is a first order (dipole) anisotropy with an amplitude of 3 mK believed to result from our motion relative to the background radiation. The prospect of finding a higher order anisotropy, such as a quadrupole, which would reflect large-scale structure in the universe has stimulated many searches. Recently groups at Princeton and Florence^{4,5} have reported a quadrupole anisotropy with 1 mK amplitude which, if confirmed, would be an important discovery and a new cosmological tool. Current theories suggest a natural interpretation for this type of anisotropy as arising from density fluctuations in the universe^{6,7}, however, the theoretical basis for a quadrupole at the level reported is questionable as it depends on the matter autocorrelation function at large scales where it is not well understood.⁸ In addition both the Princeton and Florence data are taken at wavelengths where the emission from our galaxy is a significant contaminant. One motivation for our experiment at 3 mm is to search for anisotropies at a wavelength where galactic contamination is substantially reduced.

Another motivation for this experiment is to look for the effects of the spectral distortions. By measuring the dipole amplitude at several frequencies the temperature of the radiation or its deviation from blackbody can be determined.^{9,10} Since the magnitude of the dipole anisotropy induced by our motion through the radiation depends on both the intensity and the spectral shape (derivative)¹⁰, a distorted spectrum would give a different dipole amplitude than a blackbody. The data of Woody and Richards¹¹ suggest the cosmic background radiation spectrum may be distorted at our wavelength. A precise prediction of the dipole amplitude from

their data is not possible because of their flux uncertainty and spectral resolution. However, a smooth spectrum through their data yields an estimated 20 to 40% enhancement of the dipole at our wavelength. We are currently analyzing our data for this effect and will publish the results of this soon.

A schematic of the instrument is shown in figure 1. It is a Dicke radiometer which uses a rotating mirror to chop the 7° beam between two positions in the sky 90° apart and 45° from vertical with an output proportional to their temperature difference. The receiver is a 90 GHz liquid-helium-cooled low-doped Schottky-diode mixer and GaAs FET IF based on a design by Kerr.¹² The exceptionally low noise diode was supplied by R. Mattauich of the University of Virginia. The minimum spot noise of the mixer + IF is 80 K with a system double side-band noise figure of 125 K over a 600 MHz bandwidth which gives a receiver RMS sensitivity of $13 \text{ mK/Hz}^{1/2}$. The measured emissivity of the chopper is $\epsilon = 9 \pm 1 \times 10^{-4}$ derived from the inflight offset of about 200 mK. This is in good agreement with the theoretical emissivity of $\epsilon = \frac{2\delta}{\lambda_0} \cos\theta$ for a metal reflector with the electric field normal to the plane of incidence, where δ is the skin depth, λ_0 is the free space wavelength and θ is the angle of incidence 45° . Using the DC conductivity of aluminum gives $\epsilon_{\text{theo.}} \approx 1 \times 10^{-3}$ which is consistent with the measured value. The offset is very stable with a typical time derivative of 1 mK/hour.

The package rotates at 1 revolution per minute with a resultant sensitivity of about 1 mK in one revolution. Since the dipole anisotropy is about 3 mK in amplitude it can be seen in real time as the package rotates. Figure 2 shows a section of telemetered data which clearly shows the dipole. The radiometer is calibrated on the ground with liquid nitrogen and ambient temperature targets and is calibrated inflight every

half-hour with a small ambient temperature blackbody target. Currently we are limited to an absolute calibration error of 5% though we plan to reduce this in the future. The gain of the system is stable to better than 2% during flight.

There are a number of sources of potential systematic errors. Atmospheric emission is one of them. At our altitude of 30 Km we estimate a residual vertical atmospheric emission of 10 mK. O_2 emission dominates as there are no known ozone lines in our bandwidth which is centered at 90.0 GHz. The atmospheric contribution to our signal is minimized by symmetrical beam paths. Combined with a typical gondola wobble amplitude of $1/4^\circ$ atmospheric emission contributes less than 0.1 mK to the signal. The magnetic field of the earth can be another source of spurious signal because some components are magnetically sensitive. The instrument was tested to have a magnetic field dependence of less than 0.1 mK for a field equivalent to the earth's. Thermal emission from the earth is reduced to less than 0.1 mK by the use of ground shields and a low sidelobe antenna.

Emission from the galaxy is a possible source of error in all anisotropy measurements and is a particular problem in searching for a quadrupole since the galactic emission is qualitatively a quadrupole in the northern celestial sky. Figure 3 shows the estimated galactic emission as a function of wavelength. Galactic emission in the centimeter wavelength region, where the Princeton data was taken, is dominated by synchrotron and bremsstrahlung emission whereas at submillimeter wavelengths, where the Florence data was taken, interstellar dust emission is thought to dominate. Synchrotron and bremsstrahlung emission decrease (in antenna temperature) with increasing frequency while dust emission increases. Near 3 mm wavelength there is a natural galactic minimum or window which we are trying to exploit.

The instrument has flown three times though the first flight returned only engineering data. The second and third flights were flown on the nights of November 4, 1981 and April 26, 1982 lasting 8 and 10 hours respectively. On the first two flights we flew on the gondolas of D. Wilkinson of Princeton and R. Weiss of M.I.T. respectively. We have surveyed most of the northern hemisphere and down to 14° S declination as shown in figure 4. All three flights were launched from Palestine, Texas at the National Scientific Balloon Facility (lat. 31.8° N).

Following the convention of Smoot and Lubin³ the data have been fit to first and second order spherical harmonics. Table 1 summarizes the various fits and errors. Because the data are taken from one latitude the axially symmetric first order $T_2(Y_{10})$ and second order $Q_1(Y_{20})$ spherical harmonics cannot be decoupled in a significant manner. The statistical errors are between 60 and 100 μ K on the various dipole and quadrupole parameters. The effect of the galaxy on the various dipole and quadrupole parameters appears to be 70 μ K or less, so contamination by the galaxy does not seem to be a problem at our wavelength. Modeling galactic emission with a $(\sin b)^{-1}$ distribution (truncated at galactic latitude $b = 5^{\circ}$) gives a marginally significant fit with a pole ($b = 90^{\circ}$) value of 50 ± 20 μ K. Excluding data within 5° of the galactic plane gives a result consistent with no galactic emission indicating the dust is probably more localized than a $(\sin b)^{-1}$ model).

Our data do not show a significant quadrupole amplitude contrary to previous reports. The quadrupole reported by the Princeton and Florence groups should give 10σ results (in Q_2) at our sensitivity. New data from the Princeton group¹³ using a maser at 1.2 cm and a new galactic model also shows no significant quadrupole. Our data indicate there is no quadrupole in the cosmic background radiation above the tenths of millikelvin level.

This project would not have been possible without the encouragement and assistance of B. Price, D. Wilkinson and R. Weiss. Special thanks go to N. Boggess, R. Kubara and the entire staff of the National Scientific Balloon Facility for their support and assistance during our flights. This work was supported by the California Space Institute, CS48-81, National Aeronautics and Space Administration NAGW-66 and the National Science Foundation SPI 8166057.

a) NSF Postdoctoral Fellow

b) John and Fanny Hertz Foundation Fellow

¹B. Corey and D. Wilkinson, Bull. Am. Astron. Soc. 8, 351 (1976).

²G. Smoot, M. Gorenstein and R. Muller, Phys. Rev. Lett. 39, 14, 898 (1977).

³G. Smoot, and P. Lubin, Ap. J. Lett. 234, L83 (1979).

⁴R. Fabbri, I. Guidi, F. Melchiorri and V. Natale, Phys. Rev. Lett. 44, 1563 (1980).

⁵S. Boughn, E. Cheng and D. T. Wilkinson, Ap. J. Lett. 243, L113 (1981).

⁶P. J. E. Peebles, Ap. J. Lett. 243, L119 (1981).

⁷J. Silk and M. Wilson, Ap. J. Lett. 244, L37 (1981).

⁸P. J. E. Peebles, Ap. J. Lett. 263, (1982).

⁹P. Lubin, NASA COBE rep. #5020 (1980).

¹⁰P. Lubin, to be published in "Enrico Fermi Summer School on Gamow Cosmology" Varenna (1982).

¹¹D. Woody and P. Richards, Phys. Rev. Lett. 42, 925 (1979).

¹²H. Cong, A. R. Kerr and R. J. Matlack, IEEE MTT-27, 3, 245 (1979).

¹³D. Fixsen, Ph.D. Thesis, Princeton University (1982).

TABLE I. Summary of Fits in Antenna Temperature

Function	Fit (mK)		Statistical Error (mK)		Total Error (mK)		Correlation Coefficients*	
	All Data	Gal. Cut 5°	Error	Total	Error	Total		
Dipole Only								
T _x	-2.89	-2.94	0.07	0.14	1.00	0.11	0.01	
T _y	0.51	0.57	0.07	0.08		1.00	-0.10	
T _z	-0.27	-0.31	0.07	0.08			1.00	
Dipole and Quadrupole								
T _x	-2.90	-2.94	0.09	0.15	1.00	-0.07	0.03	-0.39 0.23 -0.02 0.05
T _y	0.50	0.55	0.09	0.10		1.00	-0.02	0.27 -0.32 -0.11 0.02
T _z	-0.23	-0.28	0.08	0.09			1.00	0.03 0.10 -0.02 0.20
Q ₂	0.19	0.12	0.10	0.11			1.00	-0.11 -0.08 0.05
Q ₃	0.22	0.16	0.09	0.10		1.00	-0.01	0.09
Q ₄	-0.08	-0.07	0.07	0.08			1.00	0.00
Q ₅	0.05	0.07	0.06	0.07				1.00

* Correlation coefficients for full data set, no galaxy cut.

$$T = T_x \cos \delta \cos \alpha + T_y \cos \delta \sin \alpha + T_z \sin \delta + Q_1 \left(\frac{3}{2} \sin^2 \delta - \frac{1}{2} \right) + Q_2 \sin 2\delta \cos \alpha + Q_3 \sin 2\delta \sin \alpha + Q_4 \cos^2 \delta \cos 2\alpha + Q_5 \cos^2 \delta \sin 2\alpha.$$

FIGURE CAPTIONS

Fig. 1. Schematic of 3 mm radiometer

Fig. 2. Section of telemetered data from April 1982 flight taken at 06:15 hours universal time (UT). This time corresponds to a zenith right ascension of 14.20 hours. The signal was smoothed with a 55 s RC time constant. The dipole anisotropy is clearly evident as a modulation synchronous with the rotation of the gondola.

Fig. 3. Estimated galactic emission as a function of wavelength. The first order anisotropy (dipole) for a 3 K blackbody is shown for comparison.

Fig. 4. Sky coverage obtained from flights.

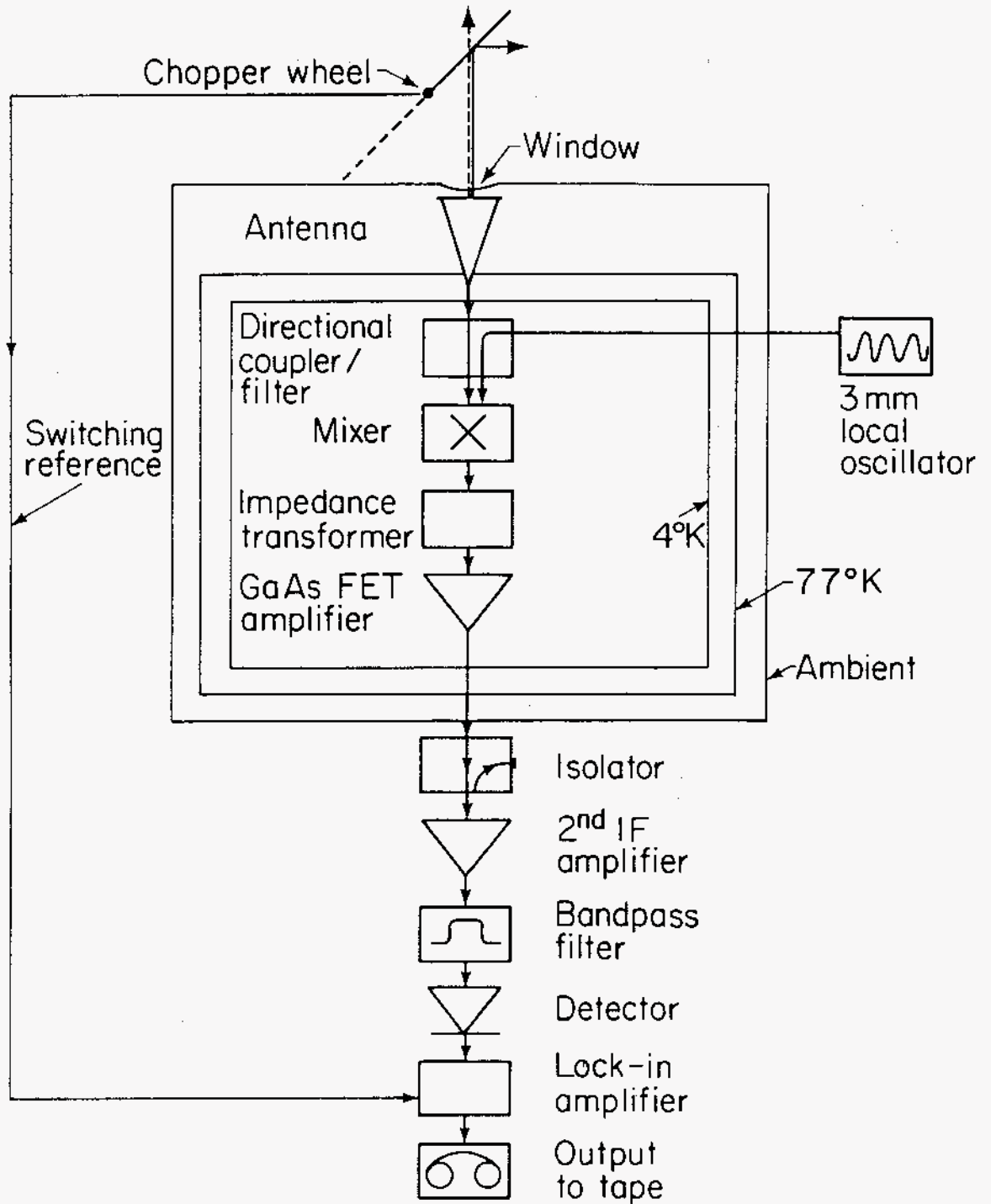

XBL 814-2228

Figure 1

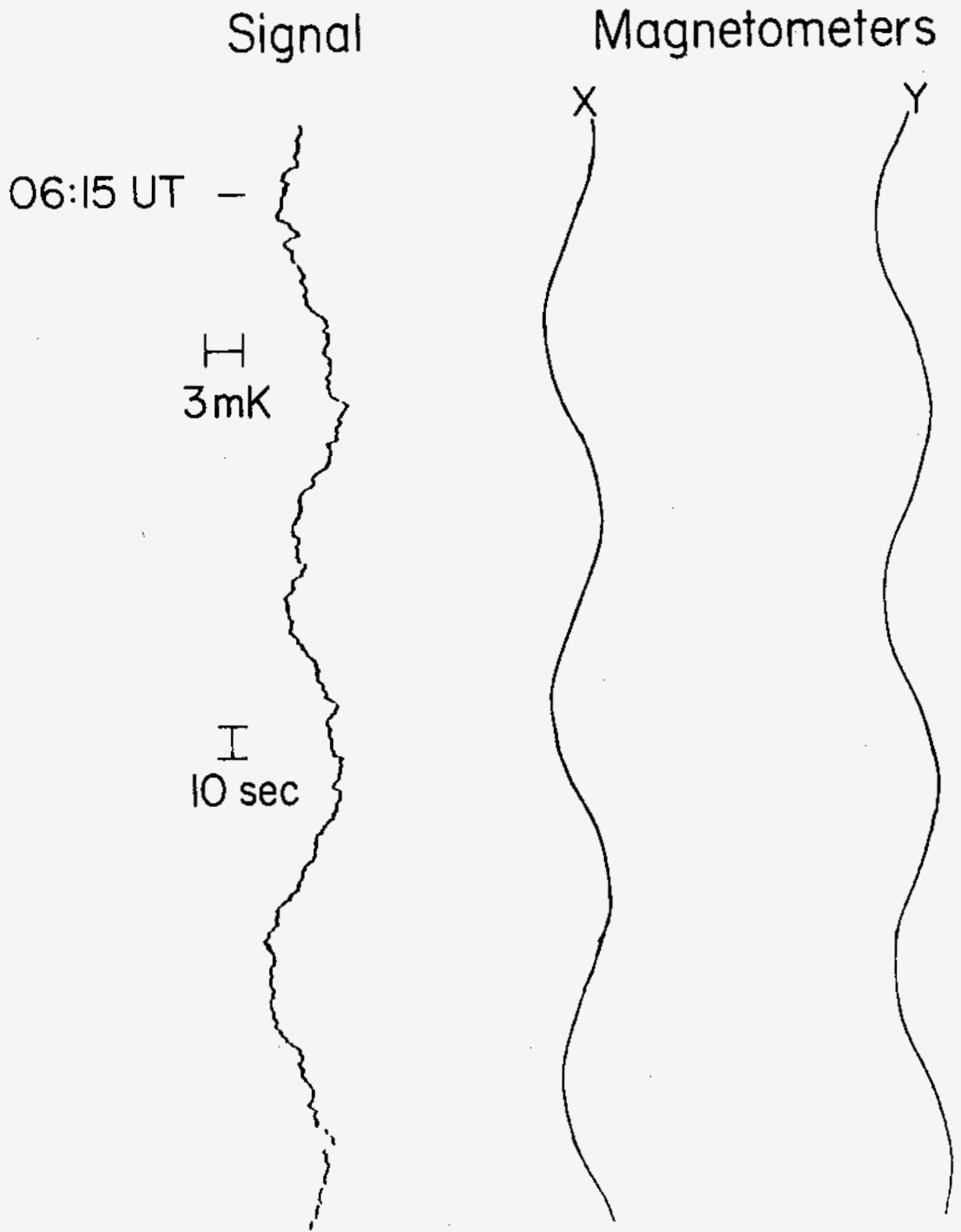

XBL 827-10582 A

Figure 2

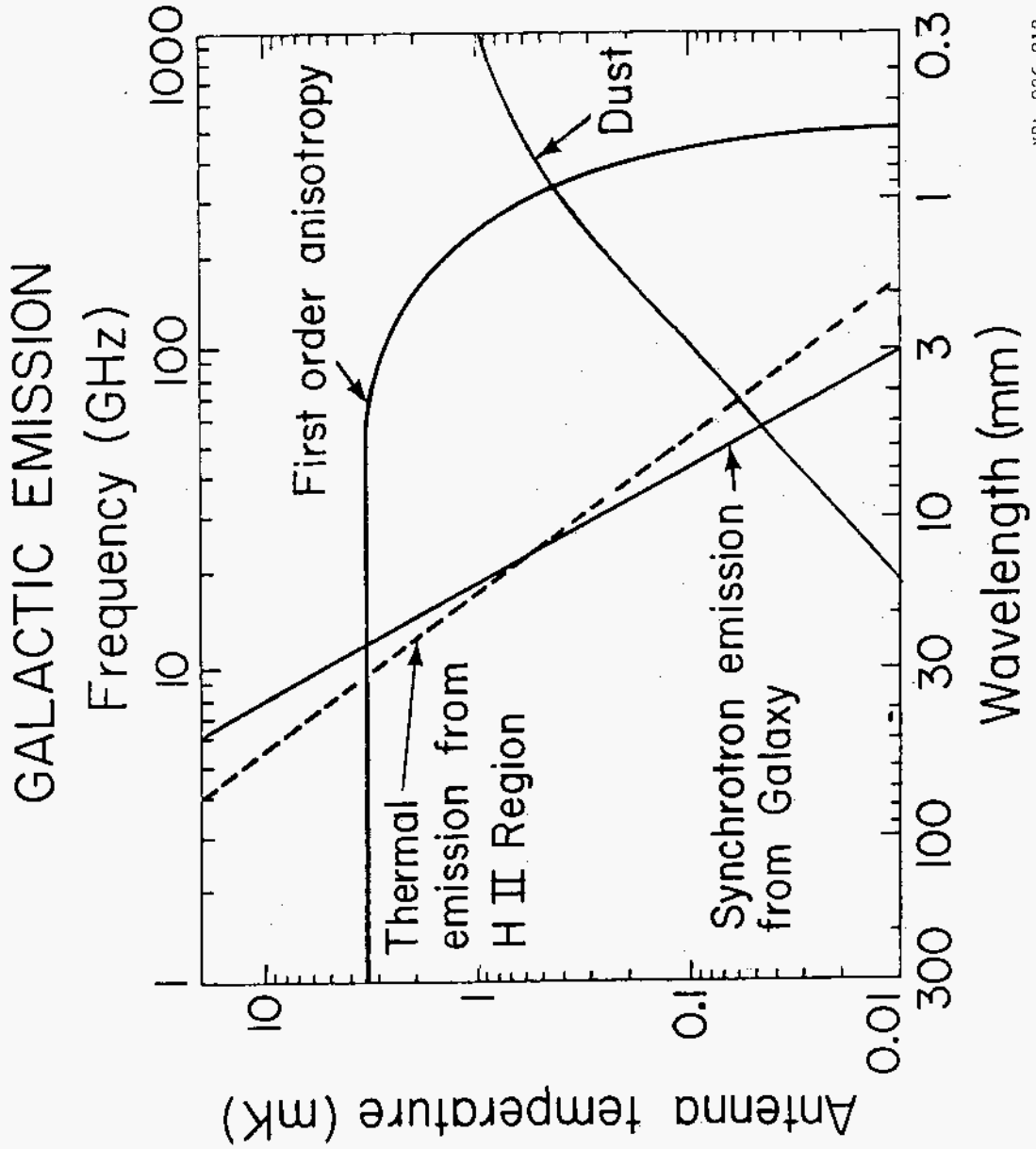

XBL 826-812

Figure 3

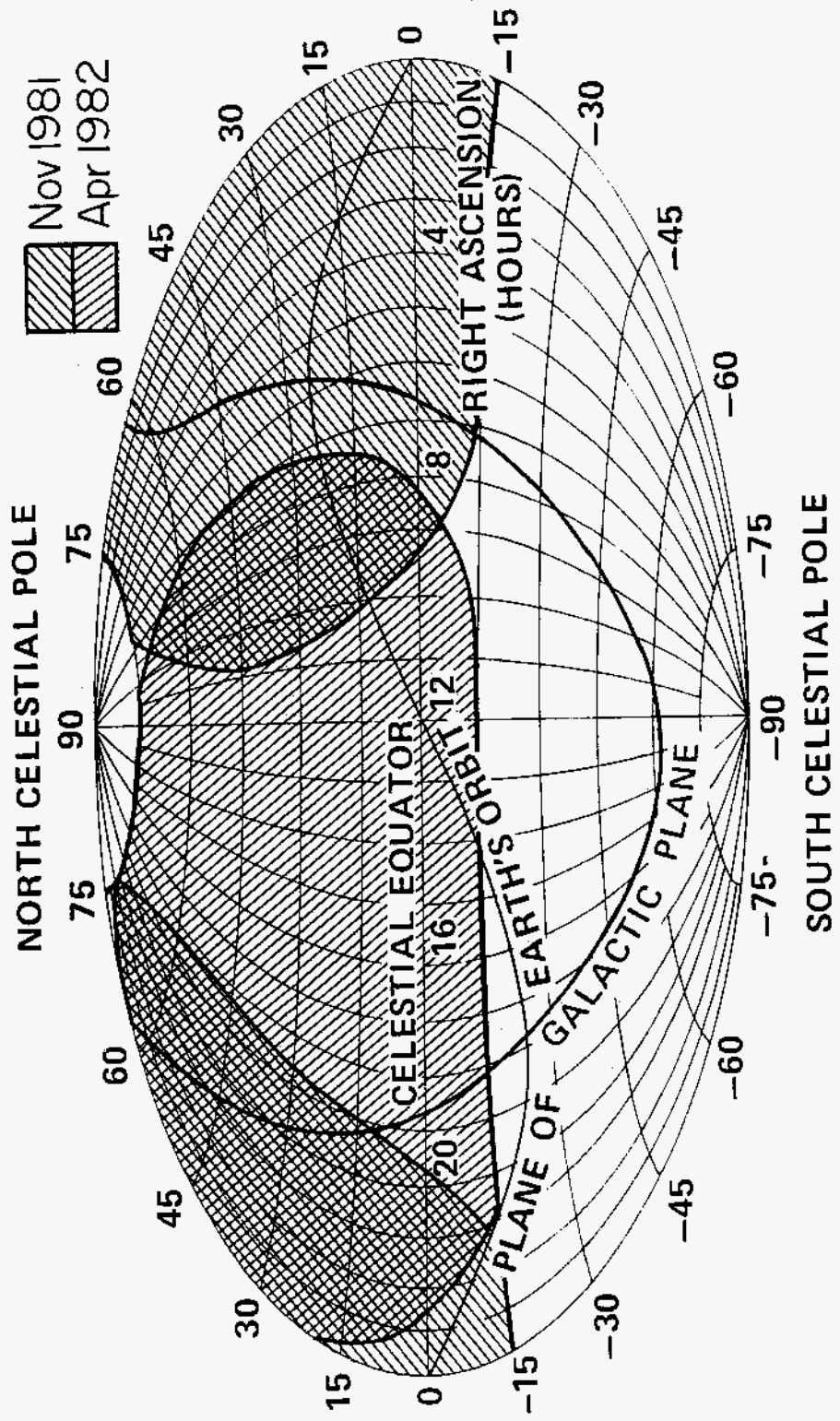

XBL 8210-3134

Figure 4