

3D/Inkjet-printed Origami Antennas for Multi-direction RF Harvesting

John Kimionis*, Apostolos Georgiadis[†], Michael Isakov[‡], Hang J. Qi[‡], and Manos M. Tentzeris*

*School of Electrical and Computer Engineering, Georgia Institute of Technology, Atlanta, Georgia 30332-0250

Email: ikimionis@gatech.edu, etentze@ece.gatech.edu

[†]Centre Tecnologic de Telecomunicacions de Catalunya, Castelldefels 08860, Spain

Email: ageorgiadis@cttc.es

[‡]School of Mechanical Engineering, Georgia Institute of Technology, Atlanta, Georgia 30332-0250

Email: misakov3@gatech.edu, qih@me.gatech.edu

Abstract—A system design is presented for radio frequency (RF) energy harvesting on wireless sensor network (WSN) nodes, where all electronics reside inside a 3D structure and the antennas lie on the surfaces of it. Additive manufacturing techniques are used for the packaging and antenna fabrication: A 3D-printed cross-shaped structure is built that folds to a cuboid in an “origami” fashion and retains its shape at room temperature. Inkjet printing is used to directly fabricate antennas on the surfaces of the 3D-printed plastic, enabling a fully additive manufacturing of the structure. Multiple antennas on the cube’s surfaces can be used for RF energy harvesting of signals arriving from totally orthogonal directions, with the use of an appropriate harvester. The system modules (cube, antenna, harvester) are described and characterized, offering a proof-of-concept for the combination of fabrication techniques to build systems for demanding RF applications.

Index Terms—RF energy harvesting, multiple antennas, additive manufacturing, inkjet printing, 3D printing.

I. INTRODUCTION

Low-cost and low-power connectivity is a necessity for large-scale wireless sensor networks (WSNs). Power sufficiency is one of the most important scopes of designing WSNs, and radio frequency (RF) energy harvesting gradually proves that it is an enabling technology for demanding low-power applications. The need for manually replacing batteries can be eliminated by utilizing RF harvesting for autonomous sensor operation, or for automatic battery recharging on-site [1], [2].

Towards that direction, a system design has been conceived that will benefit WSN nodes in terms of harvesting and, possibly, communication: All electronics of the WSN node can reside inside 3D enclosures, such as cubes, that can be easily deployed on a field. Currently, most WSN nodes employ either wire monopole/dipole antennas, or planar patch antennas. In both cases, the direction of maximum directivity is limited to one dimension. Employing a 3D structure, such as a cube, allows placing multiple antennas on it that face to different directions. RF waves from totally orthogonal planes can be exploited for harvesting and backscatter communication, increasing the total system efficiency when multiple sources are present. Such a system can also benefit in the case of a single source that lies in an unknown direction: two orthogonal antennas increase the probability of capturing the source-emitted plane waves, compared to a single antenna facing to a single direction that can only capture RF signals

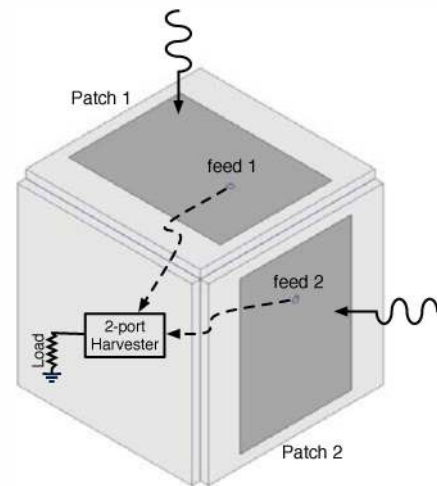

Fig. 1. 3D cube with orthogonal-direction patch antennas on the sides and RF energy harvesting electronics inside.

from multipath reflections. Finally, the multiple antennas on the sides of a compact cube can be tuned to different frequency bands to benefit from ambient energy due to different sources: FM radio, cellular networks, or Wi-Fi transmissions.

In this paper, the modules of the 3D energy harvesting system are described and characterized, to demonstrate the usability of 3D-printed structures for wireless applications, such as WSNs. Antennas are inkjet-printed on top of the 3D-printed structures, thus showcasing the potential of combining additive manufacturing technologies for complex RF applications.

II. 3D ANTENNAS

Due to the nature of the structure, where all electronics will reside *inside* the cube, the antennas are designed as probe-fed patches. A coaxial connector is used on the inside of the cube that extends to a pin reaching the surface of the antenna to excite it. The main advantage of using patch antennas is that a ground plane on the backside of the cube’s surfaces will limit the electromagnetic coupling between the antenna and the electronics circuit board.

The cube has been modeled in the ANSYS High Frequency Structure Simulation (HFSS) software, and two patches for the 2.4 GHz band have been designed on two sides of the cube,

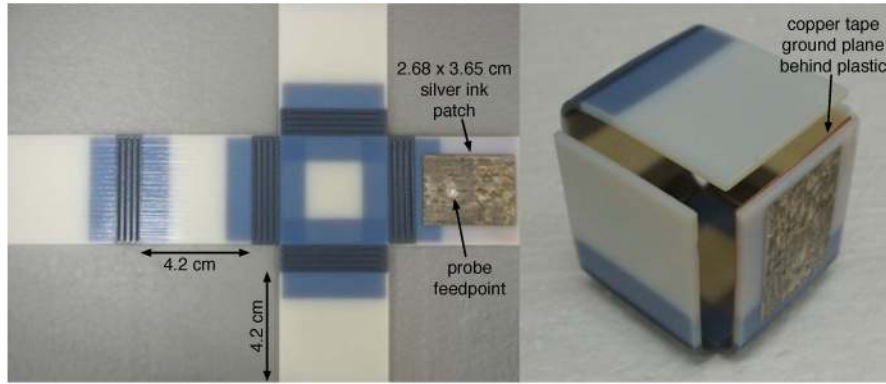

Fig. 2. Left: Inkjet-printed patch antenna on unfolded 3D-printed cube. Right: “Origami”-folded cube after heating, shaping, and cooling down.

so that they face to orthogonal directions (Fig. 1). The cube sides are 4.2×4.2 cm squares (determined by the 3D printer maximum printing dimensions), with the patches centered on them and feature a thickness of 2 mm. The patch width is $W = 2.68$ cm and its length is $L = 3.65$ cm. The probe feeding point resides 0.73 cm away from the center of the patch, along the L dimension. During simulation, it had to be determined whether the topology of the two orthogonal antennas would pose significant coupling effects and degrade the performance of each patch. It has been concluded that the two antennas do not affect each other, which offers the flexibility of placing antennas on virtually any side of the cube.

As a proof of concept and for to minimize fabrication time and cost, the cube has been designed as a cross, consisting of square slabs connected with hinges (Fig. 2-left). The hinges allow the cross to fold in “origami” style to a cuboid shape and provide mechanical support to the structure. The cross has been fabricated with a 3D-printer, using VeroWhitePlus RGD835 material for the sides and Grey60 RGD8530-DM for the hinges. Both materials are rigid in room temperature, while the hinges become very flexible when heated for 2–3 minutes at $60\text{--}70^\circ\text{C}$. After heating, the cross can be folded to a cube; as the structure cools back to room temperature, the hinges cease being flexible, while they preserve the folded shape (shape memory). At that point, the hinges provide good mechanical support to the sides, and the structure remains sturdy (Fig. 2-right). The surface of the 3D-printed structure has a glossy finish, to minimize the roughness on the antenna plane.

A patch antenna has been fabricated on one of the sides of the (unfolded) cube, to demonstrate the feasibility of inkjet printing on 3D-printed structures. Two layers of conductive silver nanoparticle ink have been printed directly on the material, to form the patch area. The patch cannot be fully fabricated with nanoparticle ink. The two reasons for that are:

- 1) The VeroWhite plastic is hydrophobic, and does not allow the formation of continuous and conductive squares with silver nanoparticles, i.e. discrete drops are formed.
- 2) The silver nanoparticle ink needs to be sintered at temperatures more than 120°C to achieve maximized

conductivity. However, this is the maximum temperature that can be tolerated by the 3D-printed plastics.

For the above reasons, a reactive silver ink is used, that can achieve good conductivity with no high-temperature sintering [3]. This ink is nanoparticle-free and has a low viscosity; when it is inkjet-printed over the patch area, it fills up the gaps of the nanoparticle layers. Because the first two nanoparticle layers drops do not spread outside the patch area when they are dried, they act as *supporting layers* for the low-viscosity silver acetate ink. Twenty layers of silver acetate have been printed, with immediate heat drying between each layer deposition. The result is a solid silver patch, without any ink spreading outside the patch area (Fig. 2-left).

The dc resistance between the bottom left and the upper right corner of the inkjet-printed patch has been measured to be $0.2\ \Omega$. The backside of the plastic has been covered with adhesive copper tape, to form the ground plane of the antenna. It must be noted that copper tape and silver ink can be used interchangeably for the patch and ground plane fabrication. A hole has been drilled to accommodate the SMA feeding pin, which has been trimmed to match the height of the antenna plane. Conductive silver epoxy has been used to electrically connect the probe pin to the inkjet-printed silver, and at the same time provide mechanical support for the SMA connector at the backside of the plastic slab. The return loss of the patch antenna has been measured with a lab vector network analyzer (VNA), and it is shown in Fig. 3. The antenna is tuned around 2.35 GHz with a matching better than -12 dB.

III. HARVESTER DESIGN

The harvester consists of two rectification circuits; a single-stage voltage doubler is utilized for *each* antenna port for high efficiency, built with HSMS-285 zero-bias Schottky diodes. The outputs of the rectifiers are combined at a single dc terminal that drives the load (Fig. 4-left). At the output terminal, a large $0.22\ \mu\text{F}$ dc capacitor is used for smoothing, along with a high-frequency $6.8\ \text{pF}$ capacitor that operates below its self-resonance frequency. A small load of $R_L = 2\ \text{K}\Omega$ is driven by the harvester output. Load values of this order of magnitude

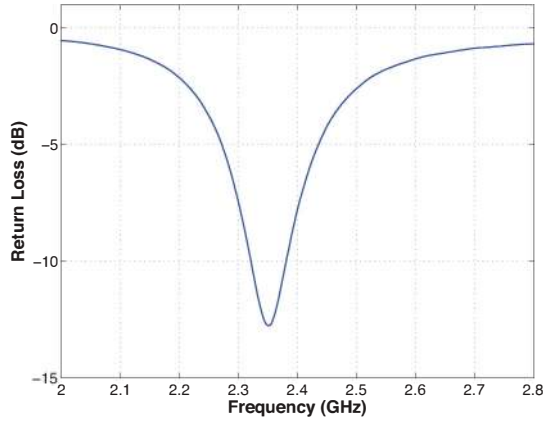

Fig. 3. Patch antenna measured return loss.

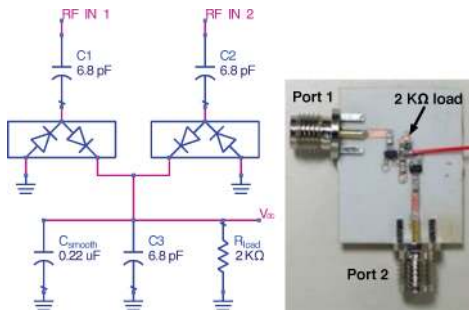

Fig. 4. Left: 2-port harvester schematic. Right: Harvester fabricated prototype.

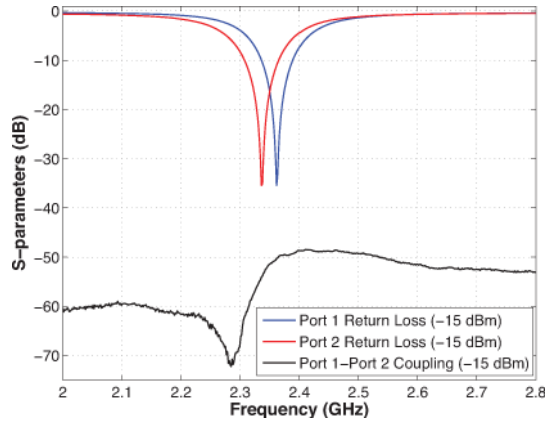

Fig. 5. Measured harvester port 1 and port 2 return loss and coupling.

can be found in devices such as low-power microcontrollers that can be used for WSN node implementations.

The 2-port harvester has been designed and simulated with the Agilent Advanced Design System (ADS) software, using large signal S-parameters (LSSP) and harmonic balance (HB) simulations. Non-linear models have been utilized for the diodes, and passive components have been simulated with models that include parasitics. The harvester has been implemented on a thin (20 mil) Rogers RO4003C laminate with $\epsilon_r = 3.55$ and $\tan \delta = 0.002$, and can be seen in Fig. 4-right.

The harvester has been tuned with single stubs for low input

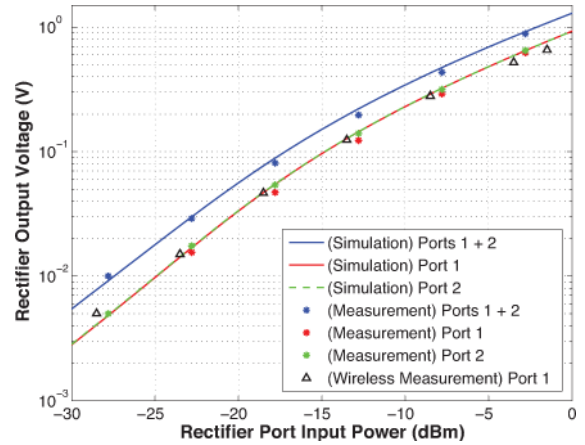

Fig. 6. Harvester output voltage versus port input power.

power levels of -15 dBm around 2.35 GHz to match the patch antenna operation. As it is shown in Fig. 5, port 1 is tuned at 2.34 GHz and port 2 at 2.36 GHz. It is noted that the two ports are strongly decoupled, with $S_{21} < -48$ dB across the 2.4 GHz band. The frequency of 2.35 GHz is selected as the operating point frequency, where both input ports have less than -15 dB return loss. The device is excited in three different scenarios to measure the output voltage: port 1 only, port 2 only, and both ports excitation. In Fig. 6, the simulated output voltage for different input power levels is shown, along with the measured values in these three scenarios. The wired measurements match with the simulation results; indicatively, at -15 dBm a voltage level of 100 mV is achieved for the 2 K Ω load when one port is excited. When both ports are excited, the voltage level is boosted to 150 mV. When the ports are excited with high power (0 dBm), the output voltage reaches 1.3 V, even though the harvester is not optimized for high input power operation.

After the wired measurements, the fabricated patch antenna has been connected to port 1 of the harvester to verify the total system operation. A signal generator has been utilized with a monopole antenna to illuminate the inkjet-printed patch at 2.35 GHz. The output power level of the generator has been tuned until a voltage level of 100 mV is obtained from the harvester; that corresponds to harvester input power of -15 dBm for one port. Then, the output voltage has been recorded for different levels of power. The wireless measurements curve fits with the simulation and the wired measurements one, verifying the system operation with the inkjet-printed antenna on the 3D-printed, “origami”-folded cube (Fig. 6).

IV. CONCLUSION

A proof-of-concept system has been fabricated to demonstrate the feasibility of inkjet-printing conductive structures on 3D-printed materials that can fold in “origami”-style. A 3D-printed cuboid has been fabricated, that can host electronics on the inside and has antennas on its sides, for multi-direction RF energy harvesting. A patch antenna has been successfully

fabricated on the cube surface, using inkjet printing, and a full RF harvesting system has been demonstrated. The proposed structure is one of the first prototypes to demonstrate the combination of additive manufacturing techniques such as 3D printing and inkjet printing, to enable the fabrication of complex structures for rugged RF and packaging applications.

ACKNOWLEDGEMENT

This work was supported by the National Science Foundation-EFRI, the Defense Threat Reduction Agency, Generalitat de Catalunya under grant 2014 SGR 1551, and the Spanish Ministry of Economy and Competitiveness and FEDER funds through the project TEC2012-39143. The authors would also like to acknowledge EU COST Action IC1301 “Wireless Power Transmission for Sustainable Electronics (WIPE).”

REFERENCES

- [1] S. Kim, R. Vyas, J. Bito, K. Niotaki, A. Collado, A. Georgiadis, and M. M. Tentzeris, “Ambient RF energy-harvesting technologies for self-sustainable standalone wireless sensor platforms,” *Proc. IEEE*, vol. 102, no. 11, pp. 1649–1666, Nov. 2014.
- [2] K. Gudan, S. Chemishkian, J. J. Hull, S. J. Thomas, J. Ensworth, and M. S. Reynolds, “A 2.4GHz ambient rf energy harvesting system with -20dBm minimum input power and NiMH battery storage,” in *IEEE Int. Conf. on RFID-Technology and Applications (RFID-TA)*, Tampere, Finland, Sep. 2014, pp. 7–12.
- [3] S. B. Walker and J. A. Lewis, “Reactive silver inks for patterning high-conductivity features at mild temperatures,” *Journal of the American Chemical Society*, vol. 134, no. 3, pp. 1419–1421, 2012.