

A 200-MHz 64-b Dual-Issue CMOS Microprocessor

Daniel W. Dobberpuhl, *Member, IEEE*, Richard T. Witek, Randy Allmon, Robert Anglin, David Bertucci, Sharon Britton, Linda Chao, *Member, IEEE*, Robert A. Conrad, Daniel E. Dever, Bruce Gieseke, Soha M. N. Hassoun, Gregory W. Hoepfner, *Member, IEEE*, Kathryn Kuchler, *Member, IEEE*, Maureen Ladd, *Member, IEEE*, Burton M. Leary, Liam Madden, Edward J. McLellan, Derrick R. Meyer, James Montanaro, Donald A. Priore, Vidya Rajagopalan, Sridhar Samudrala, and Sribalan Santhanam

Abstract—A 400-MIPS/200-MFLOPS (peak) custom 64-b VLSI CPU chip is described. The chip is fabricated in a 0.75- μm CMOS technology utilizing three levels of metalization and optimized for 3.3-V operation. The die size is 16.8 mm \times 13.9 mm and contains 1.68M transistors. The chip includes separate 8-kilobyte instruction and data caches and a fully pipelined floating-point unit (FPU) that can handle both IEEE and VAX standard floating-point data types. It is designed to execute two instructions per cycle among scoreboarded integer, floating-point, address, and branch execution units. Power dissipation is 30 W at 200-MHz operation.

I. INTRODUCTION

A RISC-style microprocessor has been designed and tested that operates up to 200 MHz. The chip implements a new 64-b architecture, designed to provide a huge linear address space and to be devoid of bottlenecks that would impede highly concurrent implementations. Fully pipelined and capable of issuing two instructions per clock cycle, this implementation can execute up to 400 million operations per second. The chip includes an 8-kilobyte I-cache, 8-kilobyte D-cache and two associated translation look-aside buffers, a four-entry 32-byte/entry write buffer, a pipelined 64-b integer execution unit with a 32-entry register file, and a pipelined floating-point unit (FPU) with an additional 32 registers. The pin interface includes integral support for an external secondary cache. The package is a 431-pin PGA with 140 pins dedicated to V_{DD}/V_{SS} . The chip is fabricated in 0.75- μm n-well CMOS

Manuscript received April 13, 1992; revised June 23, 1992.

D. W. Dobberpuhl, R. Allmon, R. Anglin, S. Britton, L. Chao, R. A. Conrad, D. E. Dever, B. Gieseke, K. Kuchler, M. Ladd, B. M. Leary, L. Madden, E. J. McLellan, D. R. Meyer, J. Montanaro, D. A. Priore, V. Rajagopalan, S. Samudrala, and S. Santhanam are with the Semiconductor Engineering Group, Digital Equipment Corporation, Hudson, MA 01749.

R. T. Witek was with the Semiconductor Engineering Group, Digital Equipment Corporation, Hudson, MA 01749. He is now with Apple Computer, Inc., Austin, TX.

D. Bertucci was with the Semiconductor Engineering Group, Digital Equipment Corporation, Hudson, MA 01749. He is now with Sun Microsystems Inc., Mountain View, CA.

S. M. N. Hassoun was with the Semiconductor Engineering Group, Digital Equipment Corporation, Hudson, MA 01749. She is now with the Computer Systems Engineering Department, University of Washington, Seattle, WA 98195.

G. W. Hoepfner was with the Semiconductor Engineering Group, Digital Equipment Corporation, Hudson, MA 01749. He is now with the Advanced Workstation Division, IBM Corporation, Austin, TX.

IEEE Log Number 9202810.

with three layers of metalization. The die measures 16.8 mm \times 13.9 mm and contains 1.68 million transistors. Power dissipation is 30 W from a 3.3-V supply at 200 MHz.

II. CMOS PROCESS TECHNOLOGY

The chip is fabricated in a 0.75- μm 3.3-V n-well CMOS process optimized for high-performance microprocessor design. Process characteristics are shown in Table I. The thin gate oxide and short transistor lengths result in the fast transistors required to operate at 200 MHz. There are no explicit bipolar devices in the process as the incremental process complexity and cost were deemed too large in comparison to the benefits provided—principally more area-efficient large drivers such as clock and I/O.

The metal structure is designed to support the high operating frequency of the chip. Metal 3 is very thick and has a relatively large pitch. It is important at these speeds to have a low-resistance metal layer available for power and clock distribution. It is also used for a small set of special signal wires such as the data buses to the pins and the control wires for the two shifters. Metal 1 and metal 2 are maintained at close to their maximum thickness by planarization and by filling metal 1 and metal 2 contacts with tungsten plugs. This removes a potential weak spot in the electromigration characteristics of the process and allows more freedom in the design without compromising reliability.

III. ALPHA ARCHITECTURE

The computer architecture implemented is a 64-b load/store RISC architecture with 168 instructions, all 32 b wide [1]. Supported data types include 8-, 16-, 32-, and 64-b integers and 32- and 64-b floats of both DEC and IEEE formats. The two register files, integer and floating point, each contains 32 entries of 64 b with one entry in each being a hardwired zero. The program counter and virtual address are 64 b. Implementations can subset the virtual address size but are required to check the full 64-b address for sign extension. This insures that when later implementations choose to support a larger virtual address, programs will still run and not find addresses that have dirty bits in the previously “unused” bits.

TABLE I
PROCESS DESCRIPTION

Feature Size	0.75 μm
Channel Length	0.5 μm
Gate Oxide	10.5 nm
V_{TN}/V_{TP}	0.5 V / -0.5 V
Power Supply	3.3 V
Substrate	P-epi with n-well
Salicide	Cobalt disilicide in diffusions and gates
Buried Contact	Titanium nitride
Metal 1	0.75- μm AlCu, 2.25- μm pitch (contacted)
Metal 2	0.75- μm AlCu, 2.625- μm pitch (contacted)
Metal 3	2.0- μm AlCu, 7.5- μm pitch (contacted)

The architecture is designed to support high-speed multi-issue implementations. To this end the architecture does not include condition codes, instructions with fixed source or destination registers, or byte writes of any kind (byte operations are supported by extract and merge instructions within the CPU itself). Also, there are no first-generation artifacts that are optimized around today's technology, which would represent a long-term liability to the architecture.

IV. CHIP MICROARCHITECTURE

The block diagram (Fig. 1) shows the major functional blocks and their interconnecting buses, most of which are 64 b wide. The chip implements four functional units: the integer unit (IRF + EBOX), the floating-point unit (FRF + FBOX), the load/store unit (ABOX), and the branch unit (distributed). The bus interface unit (BIU), described in the next section, handles all communication between the chip and external components. The microphotograph (Fig. 2) shows the boundaries of the major functional units. The dual-issue rules are a direct consequence of the register-file ports, the functional units, and the I-cache interface. The integer register file (IRF) has two read ports and one write port dedicated to the integer unit, and two read and one write port shared between the branch unit and the load store unit. The floating-point register file (FRF) has two read ports and one write port dedicated to the floating unit, and one read and one write port shared between the branch unit and the load store unit. This leads to dual-issue rules that are quite general:

- any load/store in parallel with any operate,
- an integer op in parallel with a floating op,
- a floating op and a floating branch,
- an integer op and an integer branch,

except that integer store and floating operate and floating store and integer operate are disallowed as pairs.

As shown in Fig. 3(a), the integer pipeline is seven stages deep, where each stage is a 5-ns clock cycle. The first four stages are associated with instruction fetching, decoding, and scoreboard checking of operands. Pipeline stages 0 through 3 can be stalled. Beyond 3, however, all pipeline stages advance every cycle. Most ALU operations complete in cycle 4 allowing single-cycle latency, with the shifter being the exception. Primary cache ac-

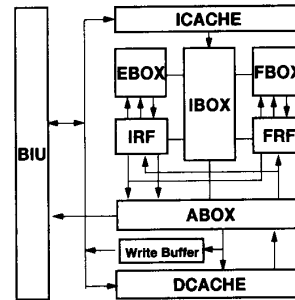

Fig. 1. CPU chip block diagram.

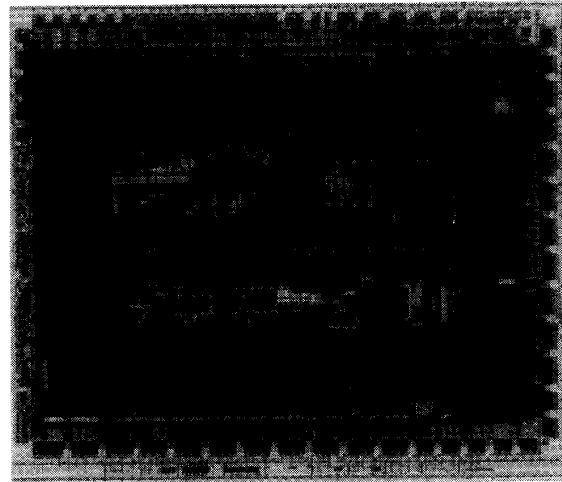
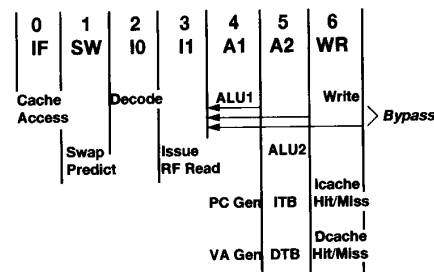
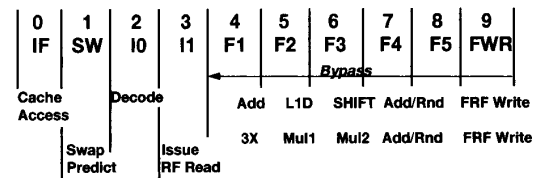

Fig. 2. Chip microphotograph.



(a)



(b)

Fig. 3. (a) Integer unit pipeline timing. (b) Floating-point unit pipeline timing.

cesses complete in cycle 6, so cache latency is three cycles. The chip will do hits under misses to the primary DCACHE.

The ISTREAM is based on autonomous prefetching in cycles 0 and 1 with the final resolution of ICACHE hit not occurring until cycle 5. The prefetcher includes a branch history table and a subroutine return stack. The architecture provides a convention for compilers to predict branch decisions and destination addresses including those for register indirect jumps. The penalty for branch mispredict is four cycles.

The floating-point unit is a fully pipelined 64-b floating-point processor that supports both VAX standard and IEEE standard data types and rounding modes. It can generate a 64-b result every cycle for all operations except division. As shown in Fig. 3(b), the floating-point pipeline is identical and mostly shared with the integer pipeline in stages 0 through 3, however, the execution phase is three cycles longer. All operations, 32 and 64 b, (except division) have the same timing. Division is handled by a nonpipelined, single bit per cycle, dedicated division unit.

In cycle 4, the register file data are formatted to fraction, exponent, and sign. In the first-stage adder, exponent difference is calculated and a $3 \times$ multiplicand is generated for multiplies. In addition, a predictive leading 1 or 0 detector using the input operands is initiated for use in result normalization. In cycles 5 and 6, for add/subtract, alignment or normalization shift and sticky-bit calculation are performed. For both single- and double-precision multiplication, the multiply is done in a radix-8 pipelined array multiplier. In cycles 7 and 8, the final addition and rounding are performed in parallel and the final result is selected and driven back to the register file in cycle 9. With an allowed bypass of the register write data, floating-point latency is six cycles.

The CPU contains all the hardware necessary to support a demand paged virtual memory system. It includes two translation look-aside buffers to cache virtual to physical address translations. The instruction translation buffer contains 12 entries, eight that map 8-kilobyte pages and four that map 4-megabyte pages. The data translation buffer contains 32 entries that can map 8-kilobyte, 64-kilobyte, 512-kilobyte or 4-megabyte pages.

The CPU supports performance measurement with two counters that accumulate system events on the chip such as dual-issue cycles and cache misses or external events through two dedicated pins that are sampled at the selected system clock speed.

V. EXTERNAL INTERFACE

The external interface (Fig. 4) is designed to directly support an off-chip backup cache that can range in size from 128 kilobytes to 16 megabytes and can be constructed from standard SRAM's. For most operations, the CPU chip accesses the cache directly in a combinatorial loop by presenting an address and waiting N CPU cycles for control, tag, and data to appear, where N is a mode-programmable number between 3 and 16 set at power-up time. For writes, both the total number of cycles and the

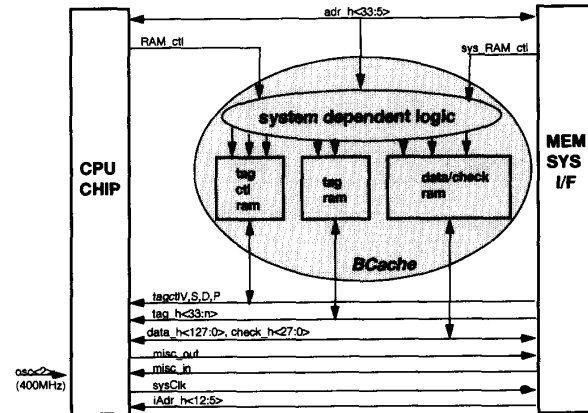

Fig. 4. CPU external interface.

duration and position of the write signal are programmable in units of CPU cycles. This allows the system designer to select the size and access time of the SRAM's to match the desired price/performance point.

The interface is designed to allow all cache policy decisions to be controlled by logic external to the CPU chip. There are three control bits associated with each back-up cache (BCACHE) line: valid, shared, and dirty. The chip completes a BCACHE read as long as valid is true. A write is processed by the CPU only if valid is true and shared is false. When a write is performed the dirty bit is set to true. In all other cases, the chip defers to an external state machine to complete the transaction. This state machine operates synchronously with the SYS_CLK output of the chip, which is a mode-controlled submultiple of the CPU clock rate ranging from divide by 2 to divide by 8. It is also possible to operate without a back-up cache.

As shown in the diagram, the external cache is connected between the CPU chip and the system memory interface. The combinatorial cache access begins with the desired address delivered on the adr_h lines and results in ctl , tag, data, and check bits appearing at the chip receivers within the prescribed access time. In 128-b mode, BCACHE accesses require two external data cycles to transfer the 32-byte cache line across the 16-byte pin bus. In 64-b mode, it is four cycles. This yields a maximum backup cache read bandwidth of 1.2 gigabyte/s and a write bandwidth of 711 megabyte/s. Internal cache lines can be invalidated at the rate of one line/cycle using the dedicated invalidate address pins, $iAdr_h \langle 12:5 \rangle$.

In the event external intervention is required, a request code is presented by the CPU chip to the external state machine in the time domain of the SYS_CLK as described previously. Fig. 5 shows the read miss timing where each cycle is a SYS_CLK cycle. The external transaction starts with the address, the quadword within block and instruction/data indication supplied on the $cWMask_h$ pins, and READ_BLOCK function supplied on the $cReq_h$ pins. The external logic returns the first 16 bytes of data on the $data_h$ and ecc or parity on the $check_h$ pins. The CPU latches the data based on receiving acknowledgment on

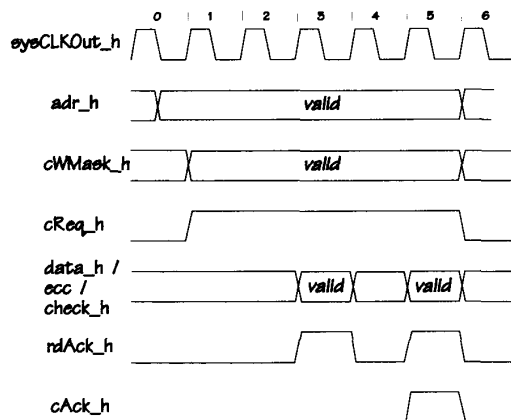

Fig. 5. CPU external timing.

rdAck_H. The diagram shows a stall cycle (cycle 4) between the request and the return data; this depends on the external logic and could range from zero to many cycles. The second 16 bytes of data are returned in the same way with *rdAck_h* signaling the return of the data and *cAck_h* signaling the completion of the transaction. *cReq_h* returns to idle and a new transaction can start at this time.

The chip implements a novel set of optional features supporting chip and module test. When the chip is reset, the first attempted action is to read from a serial read-only memory (SRAM) into the I-cache via a private three-wire port. The CPU is then enabled and the PC is forced to 0. Thus, with only three functional components (CPU chip, SRAM, and clock input) a system is able to begin executing instructions. This initial set of instructions is used to write the bus control registers inside the CPU chip to set the cache timing and to test the chip and module from the CPU out. After the SRAM loads the I-cache, the pins used for the SRAM interface are enabled as serial-in and out ports. These ports can be used to load more data or to return status of testing and setup.

VI. CIRCUIT IMPLEMENTATION

Many novel circuit structures and detailed analysis techniques were developed to support the clock rate in conjunction with the complexity demanded by the concurrence and wide data paths. The clocking method is single wire level sensitive. The bus interface unit operates from a buffered version of the main clock. Signals that cross this interface are deskewed to eliminate races. This clocking method eliminates dead time between phases and requires only a single clock signal to be routed throughout the chip.

One difficulty inherent in this clocking method is the substantial load on the clock node, 3.25 nF in our design. This load and the requirement for a fast clock edge led us to take particular care with clock routing and to do extensive analysis on the resulting grid. Fig. 6 shows the distribution of clock load among the major functional units. The clock drives into a grid of vertical metal 3 and hori-

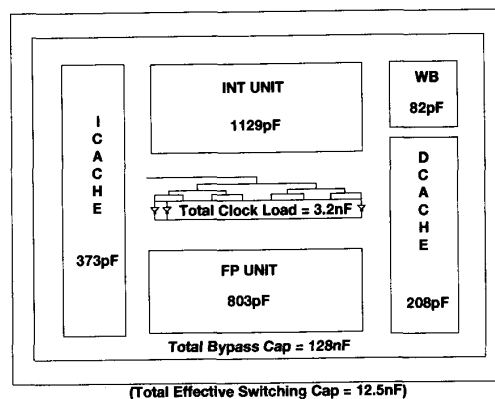

Fig. 6. Clock load distribution.

zontal metal 2. Most of the loading occurs in the integer and floating-point units that are fed from the most robust metal 3 lines. To ensure the integrity of the clock grid across the chip, the grid was extracted from the layout and the resulting network, which contained 63 000 RC elements, was simulated using a circuit simulation program based on the AWESim simulator from Carnegie-Mellon University. Fig. 7 shows a three-dimensional representation of the output of this simulation and shows the clock delay from the driver to each of the 63 000 transistor gates connected to the clock grid.

The 200-MHz clock signal is fed to the driver through a binary fanning tree with five levels of buffering. There is a horizontal shorting bar at the input to the clock driver to help smooth out possible asymmetry in the incoming wavefront. The driver itself consists of 145 separate elements each of which contains four levels of prescaling into a final output stage that drives the clock grid.

The clock driver and predriver represent about 40% of the total effective switching capacitance determined by power measurement to be 12.5 nF (worst case including output pins). To manage the problem of di/dt on the chip power pins, explicit decoupling capacitance is provided on-chip. This consists of thin oxide capacitance that is distributed around the chip, primarily under the data buses. In addition, there are horizontal metal 2 power and clock shorting straps adjacent to the clock generator and the thin oxide decoupling cap under these lines supplies charge to the clock driver. di/dt for the driver alone is about 2×10^{11} A/s. The total decoupling capacitance as extracted from the layout measures 128 nF. Thus the ratio of decoupling capacitance to switching cap is about 10:1. With this capacitance ratio, the decoupling cap could supply all the charge associated with a complete CPU cycle with only a 10% reduction in the on-chip supply voltage.

A. Latches

As previously described, the chip employs a single-phase approach with nearly all latches in the core of the chip receiving the clock node, CLK, directly. A repre-

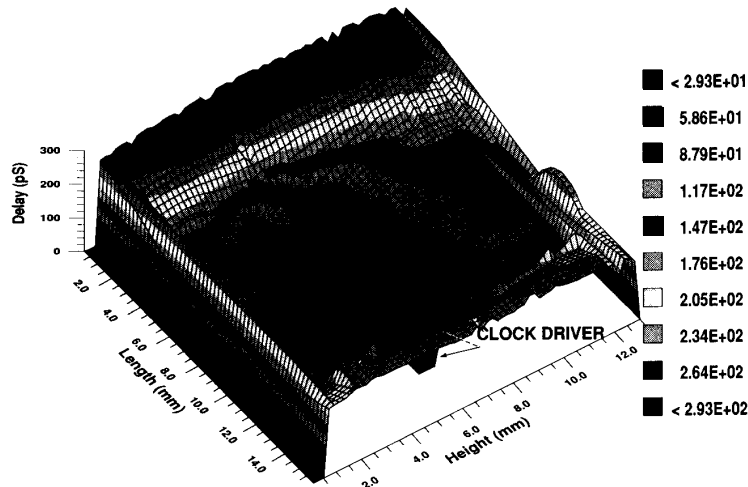

Fig. 7. CPU clock skew.

sentative example is illustrated in Fig. 8. Notice that $L1$ and $L2$ are transparent latches separated by random logic and are not simultaneously active: $L1$ is active when CLK is high and $L2$ is active when CLK is low. The minimum number of delays between latches is zero and the maximum number of delays is constrained only by the cycle time and the details of any relevant critical paths. The bus interface unit, many data-path structures, and some critical paths deviate from this approach and use buffered versions and/or conditionally buffered versions of CLK. The resulting clock skew is managed or eliminated with special latch structures.

The latches used in the chip can be classified into two categories: custom and standard. The custom latches were used to meet the unique needs of data-path structures and the special constraints of critical paths. The standard latches were used in the design of noncritical control and in some data-path applications. These latches were designed prior to the start of implementation and were included in the library of usable elements for logic synthesis. All synthesized logic used only this set of latches.

The standard latches are extensions of previously published work [2] and examples are shown in Figs. 9–11. To understand the operation of these latches refer to Fig. 9(a). When CLK is high, $P1$, $N1$, and $N3$ function as an inverter complementing IN1 to produce X . $P2$, $N2$, and $N4$ function as a second inverter and complement X to produce OUT. Therefore, the structure passes IN1 to OUT. Then CLK is “low,” $N3$ and $N4$ are cut off. If IN1, X , and OUT are initially “high,” “low,” and “high,” respectively, a transition of IN1 FALLING pulls X “high” through $P1$ causing $P2$ to cut off, which tristates OUT “high.” If IN1, X , and OUT are initially “low,” “high,” and “low,” respectively, a transition of IN1 RISING causing $P1$ to cut off, which tristates X “high” leaving OUT tristated “low.” In both cases, additional transitions of IN1 leave X tristated or driven “high” with OUT tristated to its initial value. Therefore,

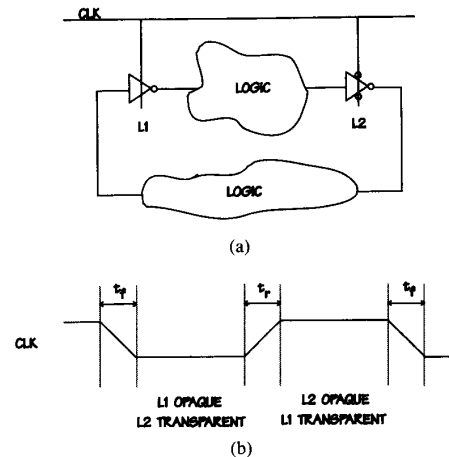

Fig. 8. (a) Latching schema. (b) Latch timing.

the structure implements a latch that is transparent when CLK is “high” and opaque when CLK is “low.” Fig. 9(c) shows the dual of the latch just discussed; this structure implements a latch that is transparent when CLK is “low” and opaque when CLK is “high.” Fig. 9(b) and (d) depicts latches with an output buffer used to protect the sometimes dynamic node OUT and to drive large loads.

The design of the standard latches stressed three primary goals: flexibility, immunity to noise, and immunity to race-through. To achieve the desired flexibility, a variety of latches like those in Figs. 9–11 in a variety of sizes were characterized for the implementors. Thus, the designer could select a latch with an optional output buffer and an embedded logic function that was sized appropriately to drive various loads. Furthermore, it was decided to allow zero delay between latches, completely freeing the designer from race-through considerations when designing static logic with these latches.

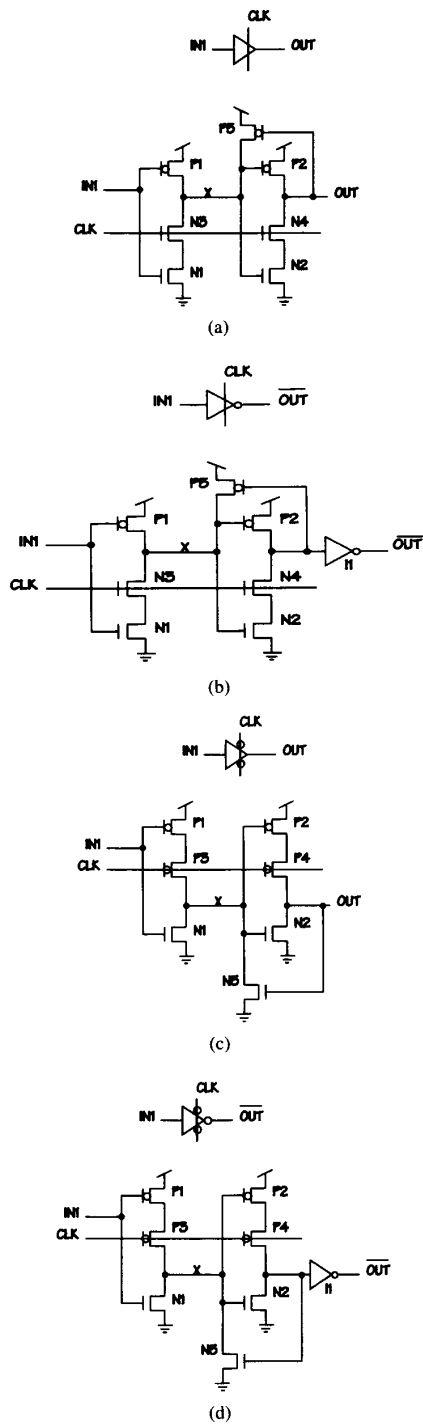

Fig. 9. (a) Noninverting active-high latch. (b) Inverting active-high latch. (c) Noninverting active-low latch. (d) Inverting active-low latch.

In the circuit methodology adopted for the implementation, only one node, X (Fig. 9(a)), poses inordinate noise margin risk. As noted above, X may be tristated "high" with OUT tristated "low" when the latch is opaque. This

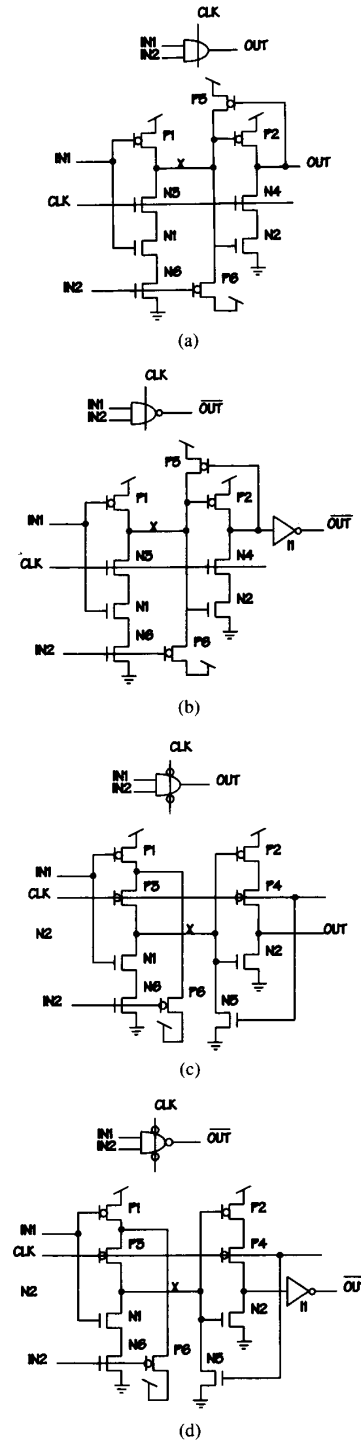

Fig. 10. (a) Two input AND active-high latch. (b) Two-input NAND active-high latch. (c) Two-input AND active-low latch. (d) Two-input NAND active-low latch.

maps into a dynamic node driving into a dynamic gate that is very sensitive to noise that reduces the voltage on X, causing leakage through P2, thereby destroying OUT.

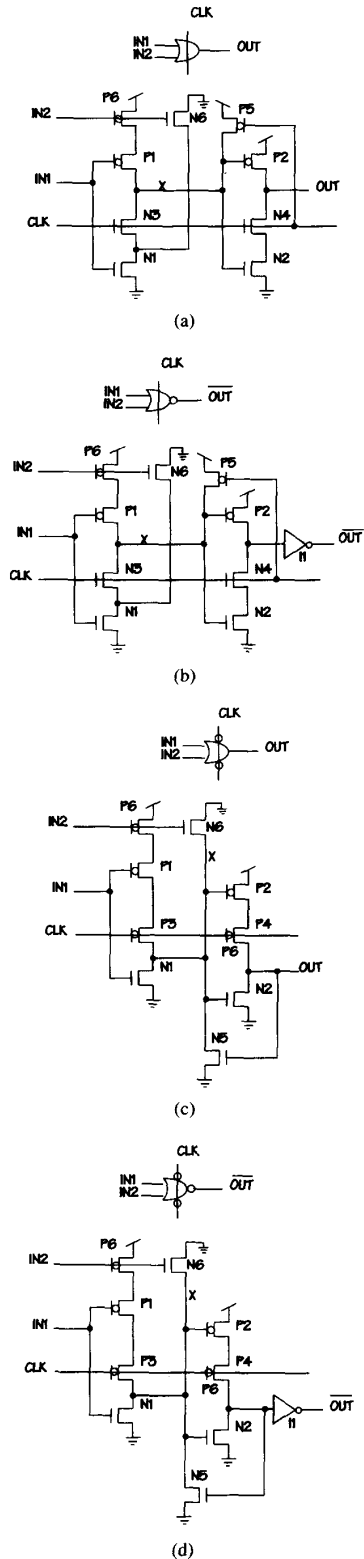

Fig. 11. (a) Two-input OR active-high latch. (b) Two-input NOR active-high latch. (c) Two-input OR active-low latch. (d) Two-input NOR active-low latch.

This problem was addressed by the addition of *P5*. This weak feedback device is sized to source enough current to counter reasonable noise and hold *P2* in cutoff. *N5* plays an analogous role in Fig. 9(c).

Race-through was the major functional concern with the latch design. It is aggravated by clock skew, the variety of available latches and the zero delay goal between latches. The clock skew concern was actually the easiest to address. If data propagate in a direction that opposes the propagation of the clock wavefront, clock skew is functionally harmless and tends only to reduce the effective cycle time locally. Minimizing this effect is of concern when designing the clock generator. If data propagate in a direction similar to the propagation of the clock wavefront, clock skew is a functional concern. This was addressed by radially distributing the clock from the center of the chip. Since the clock wavefront moves out radially from the clock driver toward the periphery of the die, it is not possible for the data to overtake the clock if the clock network is properly designed.

To verify the remaining race-through concerns, a mix and match approach was taken. All reasonable combinations of latches were cascaded together and simulated. The simulations were stressed by eliminating all interconnect and diffusion capacitance and by pushing each device into a corner of the process that emphasized race-through. Then many simulations with varying CLK rise and fall times, temperatures, and power supply voltages were performed. The results showed no appreciable evidence of race-through for CLK rise and fall times at or below 0.8 ns. With 1.0-ns rise and fall times, the latches showed signs of failure. To guarantee functionality, CLK was specified and designed to have an edge rate of less than 0.5 ns. This was not a serious constraint since other circuits in the chip required similar edge rates of the clock.

A last design issue worth noting is the feedback devices, *N5* and *P5*, in Figs. 10(c), 10(d), 11(a), and 11(b). Notice that these devices have their gates tied to CLK instead of OUT like the other latches. This difference is required to account for an effect not present in the other latches. In these latches a stack of devices is connected to node *X* without passing through the clocked transistors *P3* or *N3*. Referring to Fig. 11(a), assume CLK is "low," *X* is "high," and OUT is "low." If multiple random transitions are allowed by IN1 with IN2 "high," then coupling through *P1* can drive *X* down by more than a threshold even with weak feedback, thereby destroying OUT. To counter this phenomenon, *P5* cannot be a weak feedback device and therefore cannot be tied to OUT if the latch is to function properly when CLK is "high." Note that taller stacks aggravate this problem because the devices become larger and there are more devices to participate in coupling. For this reason stacks in these latches were limited to three high. Also, note that clocking *P5* introduces another race-through path since *X* will unconditionally go "high" with CLK falling and OUT must be able to retain a stored ONE. So there is a two-sided constraint: *P5* must be large enough to counter coupling and

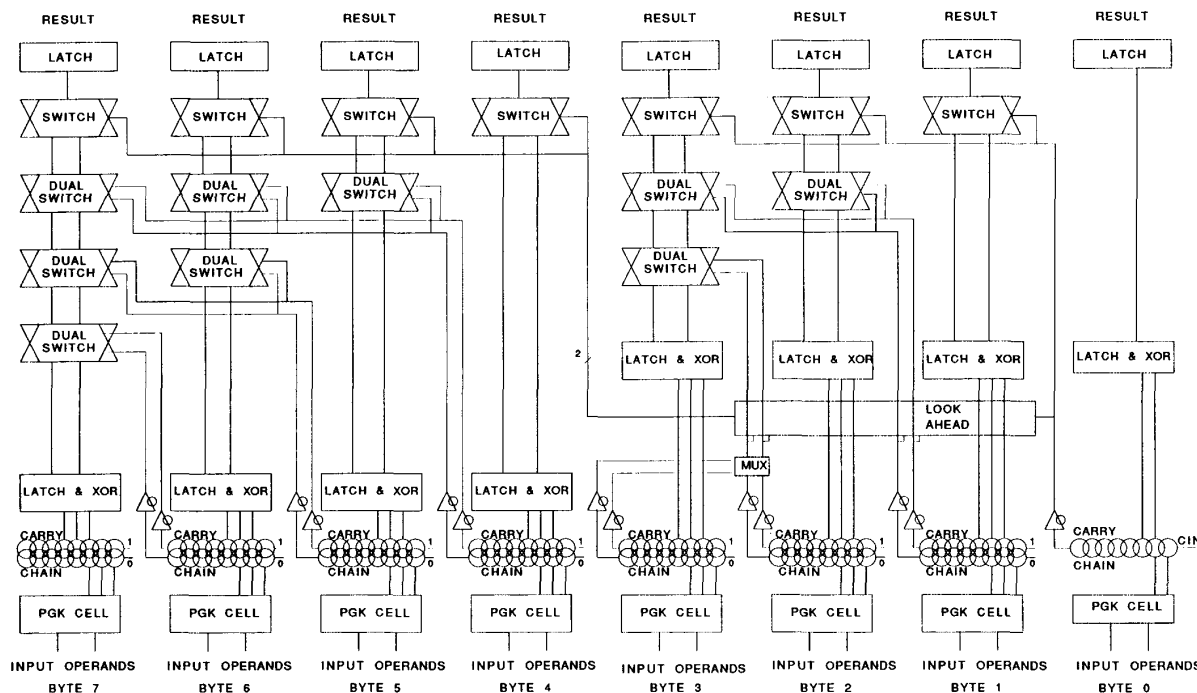

Fig. 12. 64-b adder block diagram.

small enough not to cause race-through. These trade-offs were analyzed by simulation in manner similar to the one outlined above.

B. 64-b Adder

A difficult circuit problem was the 64-b adder portion of the integer and floating-point ALU's. Unlike a previous high-speed design [3], we set a goal to achieve single-cycle latency in this unit. Fig. 12 has an organizational diagram of its structure. Every path through the adder includes two latches, allowing fully pipelined operation. The result latches are shown explicitly in the diagram, however, the input latches are somewhat implicit, taking advantage of the precharge characteristics of the carry chains. The complete adder is a combination of three methods for producing a binary add: a byte-long carry chain, a long-word (32 b) carry select, and local logarithmic carry select [4]. The carry select is built as a set of nMOS switches that direct the data from byte carry chains. The 32-b long-word lookahead is implemented as a distributed differential circuit controlling the final stage of the upper longword switches. The carry chains are organized in groups of 8 b.

Carry chain width was chosen to implement a byte compare function specified by the architecture. The carry chain implemented with nMOS transistors is shown in Fig. 13(a). Operation begins with the chain precharged to V_{SS} , with the controlling signal an OR of CLK and the kill function. Evaluation begins along the chain length without the delay associated with the $V_{gs}-V_t$ threshold found in a chain precharged to V_{DD} . An alternative to a predis-

charged state was to precharge to $V_{DD}-V_t$, but the resulting low noise margins were deemed unacceptable. From the LSB to MSB, the width of the nMOS gates for each carry chain stage is tapered down, reducing the loading presented by the remainder of the chain. The local carry nodes are received by ratioed inverters. Each set of propagate, kill, and generate signals controls two carry chains, one that assumes a carry-in and one that assumes no carry-in. The results feed the bit-wise data switches as well as the carry selects.

The long-word carry select is built as a distributed cascode structure used to combine the byte generate, kill, and propagate signals across the lower 32-b long word. It controls the final data selection into the upper long-word output latch and is out of the critical path.

The nMOS byte carry select switches are controlled by a cascade of closest neighbor byte carry-outs. Data in the most significant byte of the upper long word are switched first by the carry-out data of the next lower byte, byte 6, then by byte 5, and finally byte 4. The switches direct the sum data from either the carry-in channel or the no-carry channel (Fig. 13(b)). Sign extension is accomplished by disabling the upper long-word switch controls on long-word operations and forcing the sign of the result into both data channels.

C. I/O Circuitry

To provide maximum flexibility in applications, the external interface allows for several different modes of operation all using common on-chip circuitry. This includes

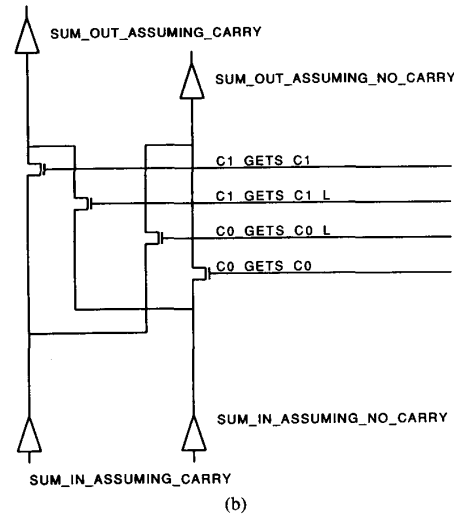
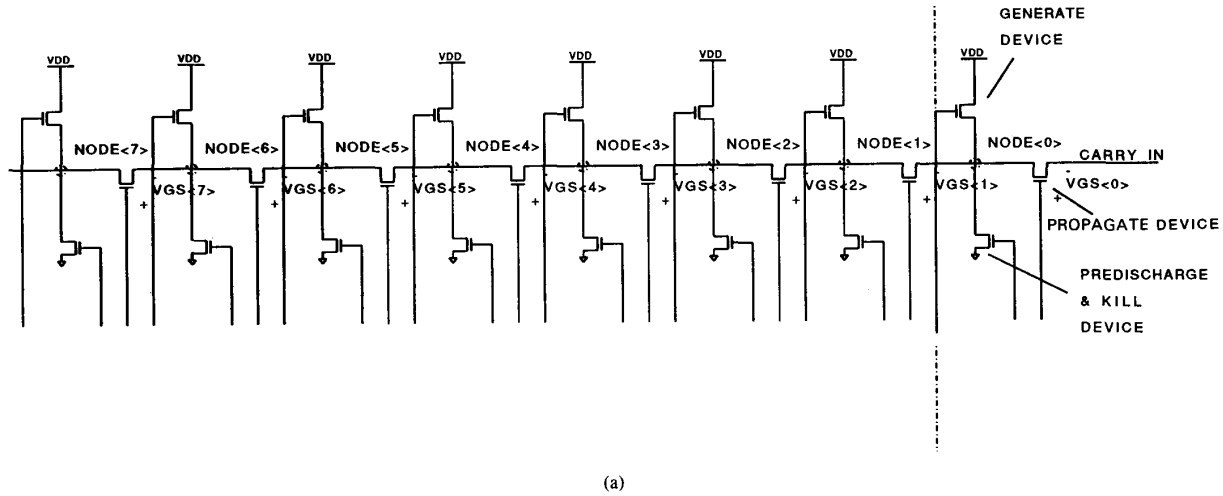

Fig. 13. (a) Adder carry chain. (b) Adder carry-select switches.

choice of logic family (CMOS/TTL or ECL) as well as bus width (64/128 b), external cache size and access time, and BIU clock rate. These parameters are set into mode registers during chip power-up. The logic family choice provided an interesting circuit challenge. The input receivers are differential amplifiers that utilize an external reference level which is set to the switching midpoint of the external logic family. To maintain signal integrity of this reference voltage, it is resistively isolated and RC filtered at each receiver.

The output driver presented a more difficult problem due to the 3.3-V V_{DD} chip power supply. To provide a good interface to ECL, it is important that the output driver pull to the V_{DD} rail (for ECL operation $V_{DD} = 0$ V, $V_{SS} = -3.3$ V). This precludes using NMOS pull-ups. PMOS pull-ups have the problem of well-junction forward bias and PMOS turn-on when bidirectional outputs are connected to 5-V logic in CMOS/TTL mode. The solution, as shown in Fig. 14, is a unique floating-well

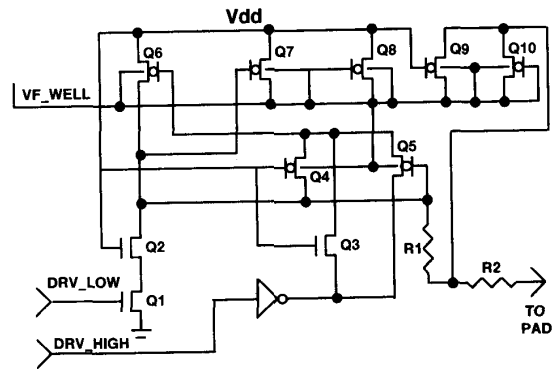

Fig. 14. Floating-well driver.

driver circuit that avoids the cost of series PMOS pull-ups in the final stage [5], while providing direct interface to 5-V CMOS/TTL as well as ECL.

Transistors $Q1$, $Q2$, and $Q6$ are the actual output devices. $Q1$ and $Q2$ are NMOS devices arranged in cascode fashion to limit the voltages across a single transistor to no more than 4 V. $Q6$ is a PMOS pull-up device that shares a common n-well with $Q7$ – $Q10$, which have responsibility for supplying the well with a positive bias voltage of either V_{DD} or the I/O pin potential, whichever is higher. $Q3$ – $Q5$ control the source of voltage for the gate of $Q6$ —either the output of the inverter or the I/O pad if it moves above V_{DD} . $R1$ and $R2$ provide 50- Ω series termination in either operating mode.

D. Caches

The two internal caches are almost identical in construction. Each stores up to 8 kilobytes of data (DCACHE) or instruction (ICACHE) with a cache block size of 32 bytes. The caches are direct mapped to realize a single cycle access, and can be accessed using untranslated bits of the virtual address since the page size is also 8 kilobytes. For a read, the address stored in the tag and a 64-b quadword of data are accessed from the caches and sent to either the memory management unit for the DCACHE or the instruction unit for the ICACHE. A write-through protocol is used for the DCACHE.

The DCACHE incorporates a pending fill latch that accumulates fill data for a cache block while the DCACHE services other load/store requests. Once the pending fill latch is full, an entire cache block can be written into the cache on the next available cycle. The ICACHE has a similar facility called the stream buffer. On an ICACHE miss, the IBOX fetches the required cache block from memory and loads it into the ICACHE. In addition, the IBOX will prefetch the next sequential cache block and place it in the stream buffer. The data are held in the stream buffer and are written into the ICACHE only if the data are requested by the IBOX.

Each cache is organized into four banks to reduce power consumption and current transients during precharge. Each array is approximately 1024 cells wide by 66 cells tall with the top two rows used as redundant elements. A six-transistor 98- μm^2 static RAM cell is used. The cell utilizes a local interconnect layer that connects between polysilicon and active area, resulting in a 20% reduction in cell area compared to a conventional six-transistor cell. A segmented word line is used to accommodate the banked design, with a global word line implemented in third-level metal and a local word line implemented in first-metal layer. The global word line feeds into local decoders that decode the lower 2 b of the address to generate the local word lines. As shown in Fig. 15, the word lines are enabled while the clock is high and the sense amplifiers are fired on the falling edge of the clock.

VII. SUMMARY

A single-chip microprocessor that implements a new 64-b high-performance architecture has been described. By using a highly optimized design style in conjunction

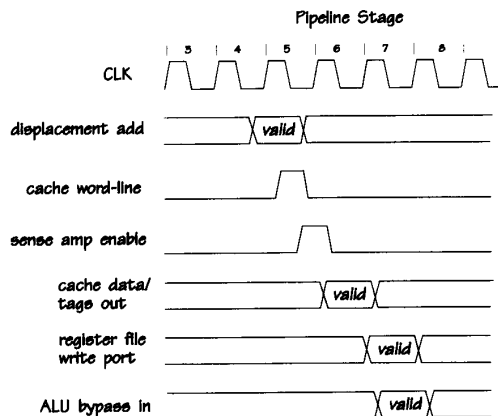

Fig. 15. DCACHE timing diagram.

with a high-performance 0.75- μm technology, operating speeds up to 200 MHz have been achieved.

The chip is superscalar degree 2 and has seven and ten stage pipelines for integer and floating-point instructions. The chip includes primary instruction and data caches, each 8 kilobytes in size. In each 5-ns cycle, the chip can issue two instructions to two of four units yielding a peak execution rate of 400 MIPS and 200 MFLOPS.

The chip is designed with a flexible external interface providing integral support for a secondary cache constructed of standard SRAM's. The interface is fully compatible with virtually any multiprocessor write cache coherence scheme, and can accommodate a wide range of timing parameters. It can interface directly to standard TTL and CMOS as well as ECL technology.

REFERENCES

- [1] *Alpha Architecture Handbook*, EC-H1689-10, Digital Equipment Corp., 1992.
- [2] J. Yuan and C. Svensson, "High-speed CMOS circuit techniques," *IEEE J. Solid-State Circuits*, vol. SC-24, no. 1, pp. 62-70, Feb. 1989.
- [3] R. Conrad *et al.*, "A 50 MIPS (peak) 32/64-b microprocessor," in *ISSCC Dig. Tech. Papers*, Feb. 1989, pp. 76-77.
- [4] J. Sklansky, "Conditional-sum addition logic," *IRE Trans. Electron. Comput.*, vol. EC-9, pp. 226-231, 1960.
- [5] H. Lee *et al.*, "An experimental 1 Mb CMOS SRAM with configurable organization and operation," in *ISSCC Dig. Tech. Papers*, Feb. 1988, pp. 180-181.



Daniel W. Dobberpuhl (M'74-S'76-M'77) was born in Streator, IL, in March, 1945. He received the B.S.E.E. degree from the University of Illinois, Urbana-Champaign, in 1967.

Subsequent to positions with the Department of Defense and General Electric Company, he joined Digital Equipment Corporation, Hudson, MA, in 1976. Since that time he has been active in the design of four generations of DEC microprocessors, including the first single chip PDP-11 and the first single-chip VAX. Most recently he was the Project Leader for the first VLSI implementation of Digital's new 64-b Alpha computing architecture. He is the co-author of the text *The Design and Analysis of VLSI Circuits* (Addison-Wesley, 1985).



Richard T. Witek received the B.A. degree in computer science from Aurora College, Aurora, IL, in 1977.

He joined Digital Equipment Corporation, Hudson, MA, in 1977, working on Phase 2 DECnet. In 1982 he joined the Digital VLSI group. In the VLSI group he worked on CAD development, MicroVAX VLSI chips, and a variety of internal RISC projects. He was a co-designer of the Alpha architecture, and the principal microarchitect of the EV-4 CPU chip. He is currently with Apple

Computer, Inc. in Austin, TX.

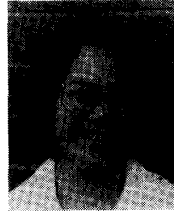

Linda Chao (M'88) received the B.S.E.E. degree from the Massachusetts Institute of Technology, Cambridge, in 1987. She is currently pursuing master's degrees in electrical engineering and management through the M.I.T. Leaders for Manufacturing Program.

Since joining Digital Equipment Corporation, Hudson, MA, in the Semiconductor Engineering Group/Advanced Development in 1987, she has been engaged in the design of full-custom VLSI microprocessors.

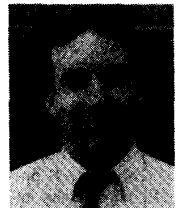

Randy Allmon received the B.S. degree in electrical engineering from the University of Cincinnati, Cincinnati, OH, in 1981.

He joined the Semiconductor Engineering Group at Digital Equipment Corporation, Hudson, MA, as a circuit designer following graduation. He has contributed to the development of numerous VAX and Alpha high-performance CMOS processors. Currently he is responsible for the technical design and management of a next-generation Alpha processor. He is the co-author of

four high-performance processor papers given at ISSCC and has one patent pending.

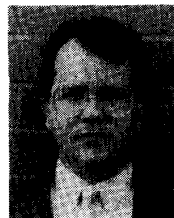

Robert A. Conrad received the B.S. degree in electrical and computer engineering from the University of Cincinnati, Cincinnati, OH, in 1984, and the M.S. degree in electrical and computer engineering from the University of Massachusetts at Amherst in 1992, where his thesis was entitled, "MPPE: A Multiport Data Driven Processing Element."

In 1981 he joined the Semiconductor Engineering Group of Digital Equipment Corporation, Hudson, MA, where he worked as a co-op in the Architecturally Focused Logic group. Since 1984 he has been engaged in the research and development of VLSI microprocessors, including Digital's MicroVAX CPU (1984), a 50-MHz RISC CPU (1989), and most recently Digital's Alpha chip.

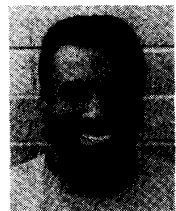

Robert Anglin was born in New York, NY, on September 3, 1965. He received the S.B. and S.M. degrees in electrical engineering in 1989 from the Massachusetts Institute of Technology, Cambridge.

In the same year he joined Digital Equipment Corporation in Hudson, MA, where he has since worked on the design of high-performance microprocessors.

Mr. Anglin is a member of Sigma Xi.

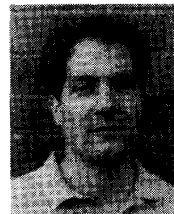

Daniel E. Dever received the B.S.E.E. degree in 1988 from the University of Cincinnati, Cincinnati, OH.

He joined the Semiconductor Engineering Group of Digital Equipment Corporation, Hudson, MA, in 1988, where he worked on the design and logic verification of CMOS VAX microprocessors. Since 1990 he has been involved in the design of RISC architecture microprocessors, including the floating-point unit of the 21064. He is currently involved in the design of integer arithmetic logic for the next-generation Alpha processor.

metric logic for the next-generation Alpha processor.

David Bertucci received the B.S.E.E. degree in 1982 from Wayne State University, Detroit, MI, and the M.S.E.E. degree in 1988 from Michigan State University, East Lansing.

He joined Digital Equipment Corporation, Hudson, MA, in 1989 where he worked on advanced CMOS microprocessor design. Currently he is employed at Sun Microsystems Inc., Mountain View, CA.

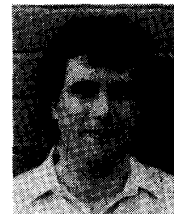

Bruce Gieseke was born in Mason, OH, on September 16, 1959. He received the B.S. degree in electrical engineering from the University of Cincinnati, Cincinnati, OH, in 1984 and the M.S. degree in electrical engineering from North Carolina State University, Raleigh, in 1985.

In 1986 he joined the Semiconductor Engineering Group, Digital Equipment Corporation, Hudson, MA, where he has been engaged in the implementation and circuit design of RISC microprocessors.

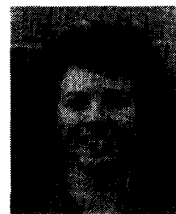

Sharon Britton received the B.S.E.E. degree from Boston University, Boston, MA, and the M.S.E.E. degree from Massachusetts Institute of Technology, Cambridge, in 1983 and 1990, respectively.

She joined Digital Equipment Corporation, Hudson, MA, in 1983, where she worked on the design and development of 80186-based controllers for read-only and write-once optical disk drives. From 1987 to 1989 she attended M.I.T. as part of Digital's Graduate Engineering Education

Program. Her graduate research involved the development of an integrated content addressable memory system with error detection capability. She returned to Digital in 1990 to join the Semiconductor Engineering Group, where she is involved in the design and implementation of high-performance CMOS microprocessors.



Soha M. N. Hassoun received the B.S.E.E. degree from South Dakota State University, Brookings, in 1986, and the S.M.E.E. degree from the Massachusetts Institute of Technology, Cambridge, in 1988. Since October 1991 she has been a student at the University of Washington, Seattle, Computer Systems Engineering Department, pursuing a Ph.D. degree.

From August 1988 to August 1991 she was employed at Digital Equipment Corporation, Hudson, MA, as a Custom Design Engineer in the Semiconductor Engineering Group. She contributed to the design of the floating-point unit of the 21064 processor.

Ms. Hassoun was the recipient of a Digital's Minority and Women's Scholarship in 1991. She was a Tau Beta Pi Fellow in 1986-1987. She was selected as the most outstanding senior in the College of Engineering in 1986.



Gregory W. Hoepfner (S'79-M'81) graduated with distinction from Purdue University, West Lafayette, IN, in 1979 where his research topic was ion-implanted optical waveguides.

In 1980 he worked at General Telephone and Electronics Research Laboratory, Waltham, MA, performing basic properties research on GaAs for fabrication of submicrometer FET's. From 1981 to 1992 he held a number of positions with Digital Equipment Corporation, Hudson, MA, most recently as co-implementation leader of Digital's

Alpha chip. He is currently employed as a Senior Engineer at IBM, Advanced Workstation Division, Austin, TX.



Kathryn Kuchler (S'89-M'90) received the B.S. degree in electrical engineering from Cornell University, Ithaca, NY, in 1990.

Upon graduation she joined Digital Equipment Corporation in Hudson, MA, where she has worked on the first implementation RISC microprocessor based on the Alpha architecture.



Maureen Ladd (S'85-M'86) received the B.S. degree in computer engineering from the University of Illinois at Urbana-Champaign in 1986.

Upon graduation she joined the Semiconductor Engineering Group within Digital Equipment Corporation, Hudson, MA, and worked on a 32-b RISC microprocessor. She received the M.S.E. degree in electrical engineering from the University of Michigan in 1990 through Digital's Graduate Engineering Education Program. Upon her return to Digital, she worked on the implementa-

tion of the first Alpha microprocessor.



Burton M. Leary received the B.S.E.E. degree from the University of Massachusetts at Amherst in 1980.

He joined Digital Equipment Corporation, Hudson, MA, in 1980 and is currently a consulting engineer in the Semiconductor Engineering Group/Advanced Development Memory Group. He designed the instruction and data caches for the Alpha CPU and is currently working on the design of advanced memory products.

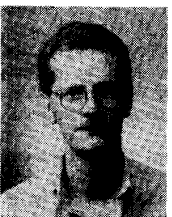

Liam Madden was born in Waterford, Ireland, on June 1, 1958. He received the B.S. degree from University College Dublin, Ireland, in 1979 and the M.E. degree from Cornell University, Ithaca, NY, in 1990.

From 1979 to 1981 he designed industrial micro-controllers for Mahon and McPhillips, Ireland. From 1981 to 1984 he worked for Harris Semiconductor, Melbourne, FL, where he contributed to the design of CMOS microprocessor peripherals. He joined Digital Equipment Corporation,

Hudson, MA, in 1984 and has since designed both CISC and RISC microprocessors and contributed in the area of CMOS process development. He is currently a Consultant Engineer in a CPU Advanced Development group and his interests include circuit design and CMOS technology development.

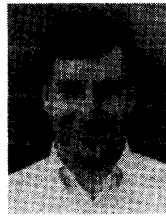

Edward J. McLellan was born in Providence, RI, on April 15, 1958. He received the B.S. degree in computer and systems engineering from Rensselaer Polytechnic Institute, Troy, NY, in 1980 where he was elected to Eta Kappa Nu.

He joined Digital Equipment Corporation, Hudson, MA, in 1980 and contributed to the design of several processor chips. He holds three patents in computer design and has an application pending.



Derrick R. Meyer was born in LaGrange, IL, on November 24, 1961. He received the B.S. degree in computer engineering from the University of Illinois, Urbana, in 1983.

In 1983 he joined the embedded controller group of Intel Corporation in Chandler, AZ, where he was involved in the design of various CMOS microcontrollers, including the 80C51 and 80C196. In 1986 he joined the Semiconductor Engineering Group of Digital Equipment Corporation in Hudson, MA, where he was initially involved in the

design of the cache and memory systems for a chilled CMOS VAX processor. He has been involved in the development of Digital's Alpha microprocessors since 1988.

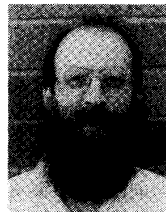

James Montanaro received the B.S.E.E. and M.S.E.E. degrees from the Massachusetts Institute of Technology, Cambridge, in 1980.

He has been with Digital Equipment Corporation, Hudson, MA, since 1982. He was a circuit designer on the floating-point chip for the LSI 11/74 and a MicroVAX peripheral chip and he led the physical implementation of the uPRISM CPU, a 70-MHz prototype RISC CPU completed in 1988.

As one of the technical leaders of the Alpha CPU chip project, he led the physical implementation of EV-3, the first Alpha CPU chip, and then contributed as a circuit designer on the EV-4 design.

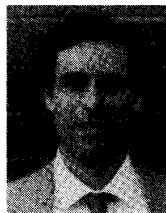

Donald A. Priore received the S.M. degree in electrical engineering and computer science from Massachusetts Institute of Technology, Cambridge, in 1984.

In 1984 he joined Digital Equipment Corporation, at their Hudson, MA, semiconductor design and manufacturing facility, working initially on device characterization, yield enhancement, and yield modeling of NMOS and CMOS processes in manufacturing. Subsequently, he joined a CMOS design group, working first with low-temperature

CMOS technology, and later with conventional CMOS in high-performance microprocessor design. His interests have included signal, clock, and power integrity in the on-chip environment. He is presently a Principle Engineer working on CMOS chip design.

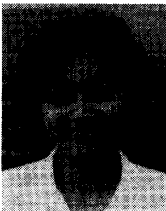

Vidya Rajagopalan received the B.E. degree in electronics engineering from Visvesvaraya Regional College of Engineering, Nagpur, India, in 1986, and the M.S. degree in electrical engineering from the University of Maryland at College Park in 1989.

She was with Norsk Data India Ltd. from 1986 to 1987 as a Systems Design Engineer. In 1989 she joined the Semiconductor Engineering Group of Digital Equipment Corporation, Hudson, MA, and was on the design team of the 21064 RISC

microprocessor. She is currently involved in the design of high-performance microprocessors at Digital.

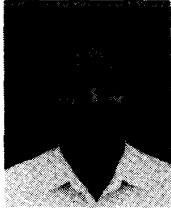

Sridhar Samudrala received the M.Sc. (Tech) degree from Andhra University, India and the M.S.E.E. degree from the University of Wisconsin, Madison.

He is currently a Project Leader for the development of a CMOS microprocessor chip at Digital Equipment Corporation, Hudson, MA, in the Semiconductor Engineering Group. He joined Digital in 1977.



Sribalan Santhanam received the B.E. degree in electrical engineering in 1987 from Anna University, Madras, India, and the M.S.E. degree in computer science and engineering in 1989 from the University of Michigan, Ann Arbor.

In 1989 he joined Digital Equipment Corporation, Hudson, MA as a Design Engineer for the Semiconductor Engineering Group, responsible for the full-custom design and development of high-performance CMOS VLSI processors. He worked on the design of the floating-point unit of

the 21064 processor including the double-precision multiplier. He is currently involved in the design of another high-performance RISC processor.