

Copyright © 1999 IEEE

Reprinted from
IEEE MTT-S International Microwave Symposium 1999

This material is posted here with permission of the IEEE. Such permission of the IEEE does not in any way imply IEEE endorsement of any of Universität Ulm's products or services. Internal or personal use of this material is permitted. However, permission to reprint/republish this material for advertising or promotional purposes or for creating new collective works for resale or redistribution must be obtained from the IEEE by writing to pubs-permissions@ieee.org.

By choosing to view this document, you agree to all provisions of the copyright laws protecting it.

A 77 GHz FM/CW RADAR FRONTEND WITH A LOW-PROFILE, LOW-LOSS PRINTED ANTENNA

Wolfgang Menzel, Dietmar Pilz, Ralf Leberer
Microwave Techniques, University of Ulm, PO Box, D-89069 Ulm, Germany

Abstract -- Design and results of a 77 GHz FM/CW radar sensor based on a simple waveguide circuitry and a novel type of printed, low-profile, and low-loss antenna are presented. A Gunn VCO and a finline mixer act as transmitter and receiver, connected by two E-plane couplers. The folded reflector type antenna consists of a printed slot array and another planar substrate which, at the same time, provide twisting of the polarization and focussing of the incident wave. In this way, a folded low-profile, low-loss antenna can be realized. The performance of the radar is described, together with first results on a scanning of the antenna beam.

I. INTRODUCTION

In the last years, a number of efforts have been spent to develop automotive radars in the 76 – 77 GHz frequency range for autonomous cruise control or collision warning, [1] – [8]. As these sensors have to be integrated into the front part of a car, very compact RF and antenna arrangements are required which, at the same time, must be suited for a low-cost mass production. With respect to the mm-wave front-end, this leads to great challenges for both transmitter/receiver circuitry and the antenna. Different types of antennas have already been investigated; the preferred choice of a planar antenna, however, suffers from its high losses [4]. In addition, the need for at least three antenna beams makes the situation even more difficult.

This contribution describes the design and realization of a 77 GHz FM/CW radar sensor based on a more standard transmitter/receiver configuration, but on a novel low-loss printed antenna configuration.

II. MM-WAVE FRONT-END

As this sensor was, in a first step, intended to test a novel arrangement of front-end and printed antenna, a rather simple metal waveguide and finline circuitry was chosen, consisting of a Gunn VCO, two E-plane waveguide couplers, and a finline balanced mixer [9]. The basic setup of this front-end is shown in Fig. 1.

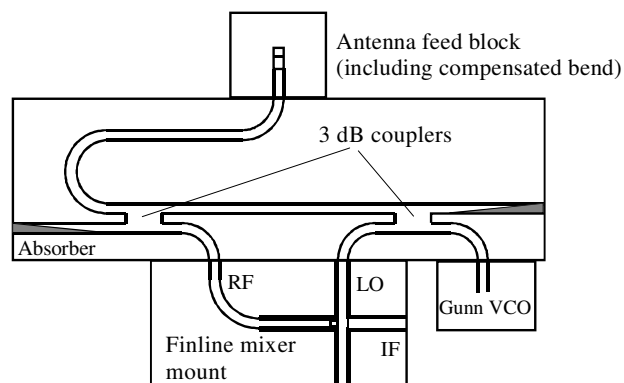

Fig. 1: Basic block diagram of the radar front-end.

The balanced finline mixer includes a thin Duroid substrate with two GaAs Schottky diodes; as an alternative, silicon diodes will be considered as well, as these typically result in lower $1/f$ -noise.

The Gunn oscillator provides an output power of 17 dBm; nearly half of this is used to drive the mixer, and the transmitted power finally amounts to about 10 dBm. Due to the arrangement with two couplers, 3 dB of power is lost both for transmit and receive; however, no complicated and expensive circulator is required, and a good isolation between transmitter output and receiver input can be achieved (35 dB between 76 and 77 GHz).

The oscillator is modulated with a triangular voltage ramp with a period of 2 ms (ramp length 1 ms). The frequency deviation is adjustable up to 200 MHz, resulting in a maximal IF frequency of 200 kHz at a maximum range of 150 m. Minimum range resolution therefore is 0.75 m.

To compensate the $1/R^4$ dependence of the received signals, the IF path includes a high pass filter with a transmission coefficient rising by approximately 12 dB per octave. In addition, this filter strongly rejects frequencies below 5 kHz to avoid problems with low frequency signals due some frequency dependent diode asymmetries.

The front-end is directly mounted to the back plate of the antenna (Fig. 2).

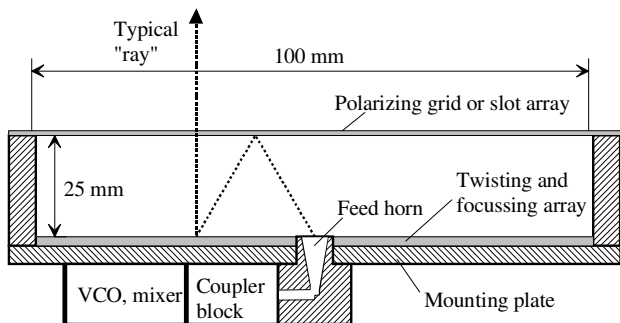

Fig. 2: Basic setup of radar sensor and basic principle of the printed folded reflector antenna.

III. PRINTED ANTENNA

A key component of this sensor is the antenna consisting of a folded planar reflector arrangement [10]. Based on the concept of planar reflector antennas [11], [12], the focussing array was modified to include a polarization twisting of the electromagnetic field. The principal function of this antenna is indicated in Fig. 2. The radiation of the feed is reflected by the printed grid or slot array at the front of the antenna. Following this, the wave is incident on a special array of dipoles printed on a standard microwave substrate with full backside metallisation. The electric field is tilted by 45° with respect to the dipole axes. The field can be decomposed into components parallel to the two axes of the dipoles. The geometrical dimensions of the dipoles are designed in such a way that, on the one hand, a phase difference of 180° occurs between

the two components of the reflected wave – giving the twisting performance, and on the other hand, an overall phase shift is achieved according to the focussing (phase shifting) requirements. The original design of this antenna is done on the basis of periodic structures, e.g. [13]. A further optimization of this type of antenna is intended based on a full wave spectral domain method [14], [15].

If the polarizing grid or slot array is replaced by a novel type of circular polarizer [16], even circular polarization can be achieved with this type of antenna.

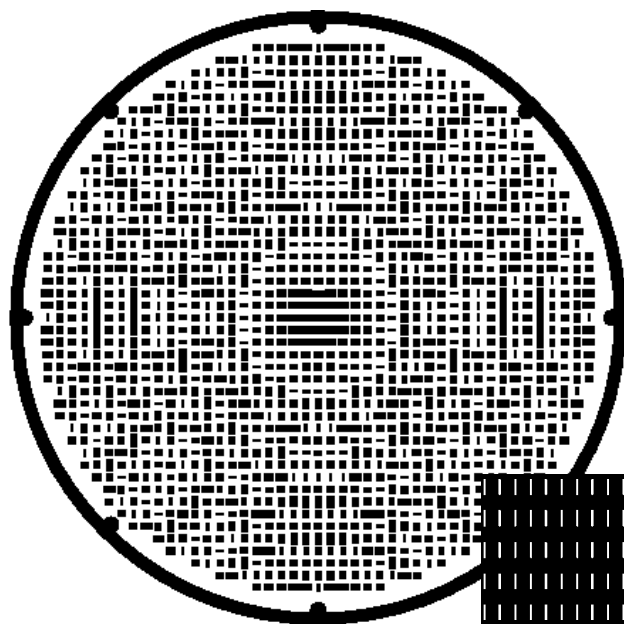

Fig. 3: Layout of twisting reflector and polarizing slot array (not to scale). Mounted in the antenna, the twisting reflector is rotated by 45° .

The antenna designed for this sensor has a diameter of 100 mm and a depth of 25 mm. The slot array is based on a TMM4 material of 1.02 mm thickness ($\epsilon_r = 4.5$), and the focussing and twisting reflector is fabricated on a Duroid material of 0.254 mm thickness ($\epsilon_r = 2.22$). The layout of this reflector is shown in Fig. 3, together with a small section of the slot array. Different to other planar antennas, the feeding of the structure is done quasi-optically; this results in considerably reduced feed losses compared, for example, to a microstrip type of antenna. Furthermore, most of the reflecting dipoles

are not in resonance, so the element losses are low, too. With a depth of only 25 mm and the fabrication of only two printed substrates, this antenna provides an interesting alternative for this type of application. The radiation diagrams in E- and H-plane of the complete antenna are plotted in Fig. 4. Beamwidth is 2.7° , and the side lobe level in both planes amounts to about 24 dB. No remarkable deterioration of the antenna diagrams could be found in the frequency range from 75.5 to 77.5 GHz; the bandwidth is even wider.

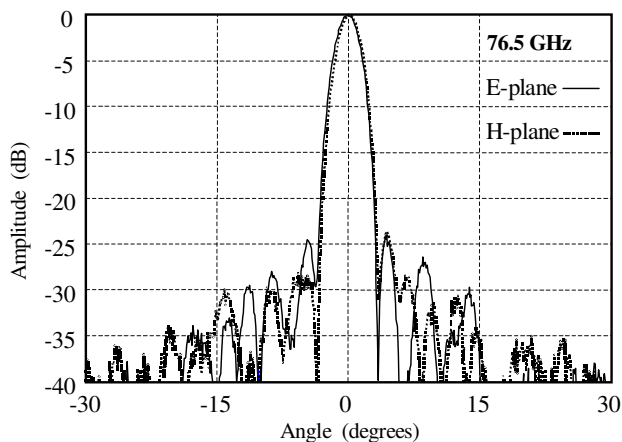

Fig. 4: Radiation diagram of the folded reflector antenna.

IV. RADAR TESTS

A test evaluation of the radar data is done via an interface card and a personal computer (laptop). The IF signal is AD converted, stored, and then transferred (at a lower speed) to the PC, where a fast Fourier transform is done. According to this procedure, only part of the ramps are accessible, and no real-time processing is done. Rising and falling slopes of the triangular ramp, however, are separately checked. In this way, it is possible – although with some slight restrictions – to evaluate both distance and speed of a target.

Fig. 5 shows the spectrum of a relatively complex stationary test arrangement. 1 kHz corresponds to 0.75 m distance (at 200 MHz frequency deviation). Fig. 6 is the result of a test with a car moving towards the stationary radar. Evaluating both rising and falling ramp, two different peaks occur in the spectrum separated by twice the Doppler frequency.

From this, a target distance of ca. 50 m and a speed of about 28 km/h (including the direction of the movement) can be derived.

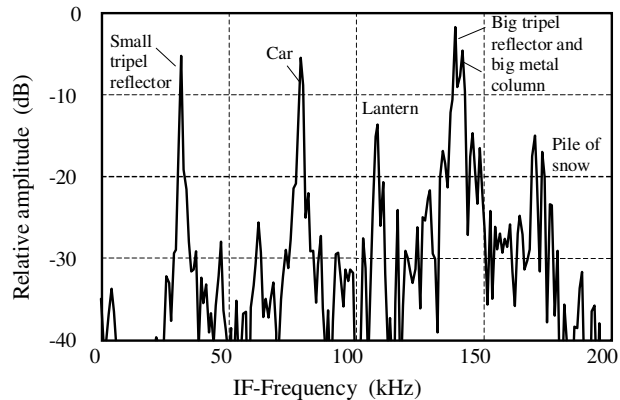

Fig. 5: IF spectrum of the radar for a complex stationary test scene.

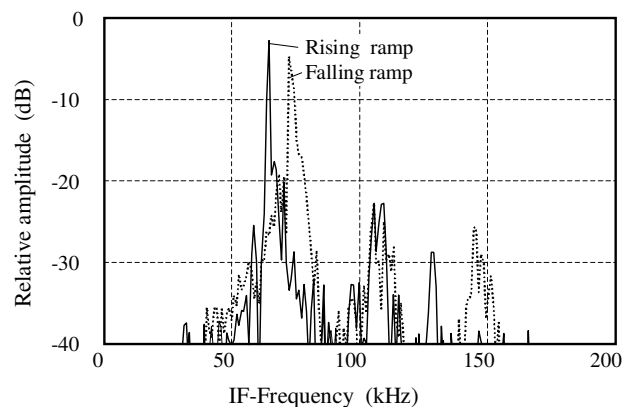

Fig. 6: IF spectrum at both rising and falling ramp for a moving car.

V. BEAM SCANNING

Present automotive radars provide at least three beams to enable a supervision of adjacent lanes. For future applications as anti-collision radar, even more beams are considered necessary. Switching between several antennas or feeds [2], mechanical scanning [5], [6], or frequency scanning [8] have been considered, or, as an alternative, monopulse antennas are employed [2], [7]. To include scanning into the antenna reported here, a modified concept with some similarity to [6] was tested (Fig. 7). By tilting the focussing and twisting plate - without moving the mm-wave front-end - the beam is scanned at twice the tilting angle of the plate. In the

test antenna, the tilted mirror simply was made adjustable by a screw and a spring. In an actual application, a small motor or a simple magnetic mechanism can take this task. In a first experiment, the antenna with vertical polarization was scanned in azimuth (H-plane) up to an angle of $\pm 9^\circ$. A number of radiation diagrams are plotted in Fig. 8. A slight asymmetry was found due to some inaccuracy in the mechanical setup. Up to a scanning angle of $\pm 6^\circ$, a side lobe level of better than 20 dB is maintained. This has to be compared to the scanning properties of standard reflector antennas with a f/D -ratio of 0.5, as it is used here. The amplitudes of the main beams vary only slightly within the scanning range investigated her.

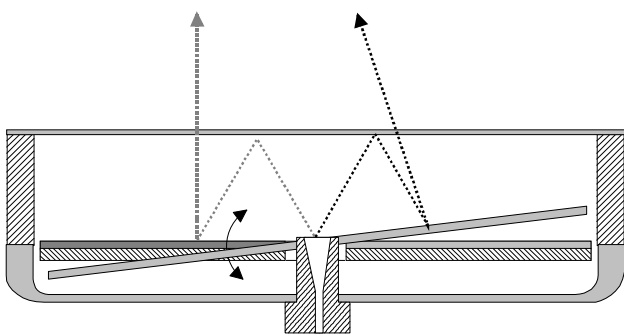

Fig. 7: Principle of beam scanning of folded reflector antenna.

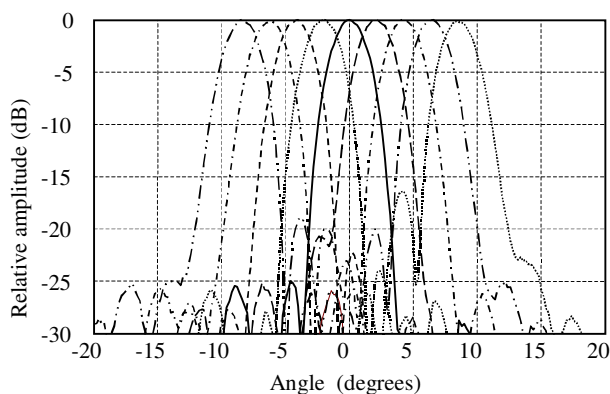

Fig. 8: H-plane radiation diagrams of scanning antenna (scanning in H-plane, $f=76.5$ GHz).

VI. REFERENCES

- [1] Meinel, H. H.: Automotive Millimeterwave Radar. 28th European Microwave Conf., 1998, Amsterdam, Netherlands, Vol. 1, pp. 619 – 629.
- [2] Daembkes, H., Luy, J. F.: Millimeterwave components and systems for automotive applications. *Microw. Engineering Europe*, Dec./Jan. 1996, pp. 43-48.
- [3] Crash avoidance FLR sensors, *Microwave Journal*, July 1994, pp. 122 - 126.
- [4] Russell, M. E. et al.: Millimeter-wave radar sensor for automotive intelligent cruise control (ICC). *IEEE Trans. Microw. Theor. Techn. MTT-45* (1997), pp. 2444–2453.
- [5] Tanizaki, T. et al.: Multi-beam automotive radar front end using non-contact cylindrical NRD switch. *IEEE Int. Microw. Symp. MTT-S*, 1998, Baltimore, pp. 521 – 524.
- [6] Erikson, L. H., Broden, S.: High performance automotive radar. *Microw. J.*, Oct. 1996, pp. 24 – 38.
- [7] Woll, J. D.: Monopuls Doppler radar for vehicle applications. *M&RF Conf.*, 1997, London, pp. 234 – 238.
- [8] Can millimetric radars take automotive control? *Microw. Engineer. Europe*, Aug./Sept. 1994, pp. 17 – 21.
- [9] Menzel, W.; Callsen, H.: 94 GHz balanced fin-line mixer. *Electron. Lett.*, 18 (1982), 5-6.
- [10] Pilz, D. Menzel, W.: Folded reflectarray antenna. *Electron. Lett.*, Vol. 34, No. 9, April 1998, pp. 832–833.
- [11] Menzel, W.: A planar reflector antenna. *MIOP '95*, Sindelfingen, Germany, pp. 608 - 612.
- [12] Pozar, D. M., Targonski, S. D., Syrigos, H. D.: Design of millimeter wave microstrip reflectarrays. *IEEE Trans. on Antennas and Propagation*, Vol. AP-45 (1997), pp. 287 – 296.
- [13] Mittra, R. et al.: Techniques for analyzing frequency selective surfaces - a review. *Proceedings of the IEEE*, 76 (12), pp. 1593 - 1615, Dec. 1988.
- [14] Pilz, D., Menzel, W. : Full Wave Analysis of a Planar Reflector Antenna. 1997 Asia Pacific Microw. Conf. APMC'97, 1997, Hong Kong, pp. 225 – 227.
- [15] Pilz, D., Menzel, W.: A mixed integration method for the evaluation of the reaction integrals using the spectral domain method. Accepted for publication in the *IEE Proc. on Microwaves, Antennas and Propagation*.
- [16] Pilz, D., Menzel, W.: A novel linear-circular polarization convertor. 28th Europ. Microw. Conf., 1998, Amsterdam, Vol. 2, pp. 18 – 23.

Acknowledgment: Thanks are due to K. Lindner, Daimler-Chrysler Aerospace, Ulm, for providing the VCO.