

**A COGNITIVE ENGINEERING ANALYSIS OF THE  
VERTICAL NAVIGATION (VNAV) FUNCTION**

Lance Sherry  
RAND/Honeywell Int'l Inc.  
PO Box 21111  
Phoenix, AZ, 85036  
[lance.sherry@honeywell.com](mailto:lance.sherry@honeywell.com)

Michael Feary  
SJSU/NASA-ARC  
Moffet Field, CA, 94035-1000  
mfeary@mail.arc.nasa.gov

Peter Polson  
Department of Psychology  
University of Colorado  
ppolson@psych.colorado.edu

Randall Mumaw  
Boeing – Commercial Airplane Group  
PO Box 3707  
Seattle, WA, 98124-2207  
randall.mumaw@pss.boeing.com

Everett Palmer  
NASA-ARC  
Moffet Field, CA, 94035-1000  
epalmer@mail.arc.nasa.gov

## **A COGNITIVE ENGINEERING ANALYSIS OF THE VERTICAL NAVIGATION (VNAV) FUNCTION**

*Abstract:* A cognitive engineering analysis of the Flight Management System (FMS) Vertical Navigation (VNAV) function has identified *overloading* of the VNAV button and *overloading* of the Flight Mode Annunciation (FMA) used by the VNAV function. These two types of overloading, resulting in modal input devices and ambiguous feedback, are well known sources of operator confusion, and explain, in part, the operational issues experienced by airline pilots using VNAV in descent and approach. A proposal to modify the existing VNAV design to eliminate the overloading is discussed. The proposed design improves pilot's situational awareness of the VNAV function, and potentially reduces the cost of software development and improves safety.

## INTRODUCTION

Each new generation of aircraft has increasing levels of flight deck automation that have improved the safety and efficiency of airline operations (Funk, 1977). The full potential of these technologies has not been fully realized however. A case in point is the potential to improve operations during the workload-intensive descent and approach phases of flight (BASI, 1999, pg 143). The Vertical Navigation (VNAV) function of the Flight Management System (FMS) serves as an intelligent agent during these phases by automatically selecting appropriate targets (e.g. altitude, speed, and vertical speed) and pitch/thrust control modes to satisfy the objectives of each leg of the flightplan. This decision-making logic is complex (Sherry & Polson, 1999; Javaux, 2000) and has raised several sets of human factors related concerns (Sarter, Woods & Billings, 1997; Federal Aviation Administration, 1996; Air Transport Association, 1999; BASI, 1999).

The VNAV function (also known as the PROF function) accounts for the majority of reported human factor issues with cockpit automation. Vakil & Hansman's (1999) review of Aviation Safety Reporting System (ASRS) reports, an anonymous incident reporting data-base for pilots, found that 63% of pilot-cockpit interaction issues were in the control of the coupled vertical/speed trajectory of the aircraft performed by the VNAV function. The Australian Transport and Regional Development Department's Bureau of Air Safety Investigation (BASI, 1999) reported that a survey of pilots identified the VNAV function as "the most disliked feature of automated cockpit systems."

Many of the issues with the use of VNAV are related to the incompatibility between the tactical Air Traffic Control (ATC) operations and the strategic FMS flightplan (BASI, 1999; Sarter, Woods, & Billings, 1997). Difficulties that pilots have in communicating ATC instructions to the FMS, via the heads-down Multi-function Control and Display Units (MCDU), and poor feedback to the pilot have also been cited (Sarter & Woods, 1992; Mangold & Eldredge, 1995; Hutchins, 1994). Researchers at Boeing, Honeywell, NASA and airline partners are actively working to address these issues (Jacobsen, Chen, & Wiedemann, 2000; Riley, 1997; Prevot, 1999; Hutchins, 1994; Faerber, 1999).

This paper describes an additional issue with the operation of the VNAV function that contributes to the pilots ability to understand what the VNAV function is doing? why it is doing that? and what it is going to do next ? (Wiener, 1988). A cognitive engineering analysis of the NASA Research VNAV function (representative of the PROF function on Airbus aircraft and the VNAV functions in modern Boeing airplanes) identified that the current design of the user-interface for the VNAV function violates two basic principles of cognitive engineering for interfaces between operators and complex automation:

1. The VNAV button is *overloaded* in descent and approach phases of flight. Selecting the VNAV button results in the engagement one of six possible VNAV commanded trajectories. Furthermore, the VNAV commanded trajectories will change autonomously as the situation evolves. The automation human factors literature (e.g., Woods, Johannesen, Cook, & Sarter, 1994) characterizes such buttons as “moded” (or

“modal”) input devices, and the behavior of the VNAV function as “autonomous” (e.g. Sarter & Woods, 1994).

2. Flight Mode Annunciation (FMA) for the VNAV function is *overloaded* in descent and approach phases of flight. The same FMA is used to represent different trajectories commanded by the VNAV function. The literature (e.g., Sherry & Polson, 1999) describes such problems as incomplete feedback from the automation to the operator of automation behaviors, goals, and internal states of the perceived situation.

Overloading of user-interface input devices and overloading of display feedback are well known sources of operator confusion (Norman, 1988). These principles are considered to contribute directly to the difficulties pilots have in learning, understanding, and predicting complex automation behavior. A team of Boeing, Honeywell, NASA and airline partners are actively working to address this issue. This paper summarizes this research to date.

### Organization of the Report

The next section summarizes the literature on issues using the VNAV function in a modern aircraft. This is followed by sections that describe the cognitive engineering principles used in this analysis, the analysis of the NASA Research VNAV function, and improvements to the current design of the VNAV function user-interface to satisfy the cognitive engineering design principles. These proposals are currently under investigation by Boeing, Honeywell, and NASA engineers and researchers. Conclusions and future work are described in the final section. For the purpose of this paper, we shall refer to the

PROF function, found on Airbus and some McDonnell Douglas aircraft, as the “VNAV function” as is common practice industry (e.g. VNAV approaches).

### ISSUES WITH VNAV OPERATION

Pilots generally use the VNAV function during the climb and cruise phases of flight. In a survey of 203 pilots at a major U.S. airline, McCrobie et al., (1997) found that 73% of pilots used VNAV in climb phase, while only 20% used the function in descent and 5% use the function in approach.

The low levels of use of the VNAV function are primarily a result of the incompatibility between the tactical operation of ATC and the strategic behavior of the FMS. BASI identified that complying with difficult air traffic control instructions in descents and approach was the most common reason for pilot workarounds of the automation (BASI, 1999; page 143). Industry, the FAA, and NASA are jointly working to create ATC procedures with greater strategic planning capability (e.g. Transport Canada, 1997) and developing decision-aiding tools for ATC controllers that optimize aircraft flow and minimize ATC tactical vectoring (NASA, 2000).

When the ATC environment allowed pilots to use the VNAV function, sixty one percent of the pilots surveyed by BASI agreed that there were things about the automation that took them by surprise (BASI, 1999: pg 156). For example, when the VNAV function is

VNAV function Issue	Percentage Pilots Reporting Surprising VNAV Behavior (Occasionally/Usually/Always)
Deceleration too early	78 %
Unexplained altitude errors	58 %
Unpredictable speed targets during approach	56 %
Unpredictable speed targets during descent	47 %
Failure to make altitude restrictions	43 %
Deceleration too late	15 %
Airplane starts down too early	14 %

*Sample of issues with VNAV function reported in a survey of 203 pilot at major U.S. Airline (McCrobie et. al., 1997)*  
*Table 1.*

used in descent and approach, pilots reported that the function does not perform the task as they had expected (Table 1).

The perceived complexity of the VNAV function has resulted in airline operators training only the basic features to operate the VNAV function (Hutchins, 1994; Lenorvitz, 1992). The airlines are effectively relying on the pilot community to discover and informally communicate to each other ways of using the function in all flight regimes. This is reflected in a series of surveys that found that pilots request additional training on VNAV and other FMS functions over all other aircraft systems (BASI, 1999, page 168; McCrobie, et. al., 1997; Sarter, Woods, & Billings, 1997).

#### User's Perspective of Issues with the VNAV Function

The VNAV function provides three automated features:

- (1) *VNAV automatically selects altitude targets and speed targets according to pilot MCP entries and the altitude and speed constraints in the FMS flightplan.*

(2) *VNAV automatically selects pitch and thrust control modes* to fly to the targets.

For example during descent, VNAV chooses between a FLCH descent, a vertical speed (fixed rate-of descent), and an FMS path descent. In the case where VNAV selects vertical speed control mode, VNAV also selects the vertical speed target.

(3) for the descent and approach, *VNAV automatically provides an optimum path* that is used as the reference for all automated altitude/speed target and control mode selections.

#### Automated selection of VNAV targets

In a study of the software of contemporary VNAV functions, Sherry & Polson (1999), found that the typical VNAV function automatically chooses the active altitude target from a possible list of sixteen, and chooses the active speed target from a possible list of twenty-six. Pilots are generally familiar with only a small set of these targets that occur most frequently and are self explanatory.

For example, the VNAV altitude target is almost always the pilot entered MCP altitude. In rare cases, when the MCP altitude has been raised above a constraint altitude in the climb phase of the FMS flightplan (or lowered below a constraint altitude in the descent phase of the FMS flightplan), the VNAV function will capture and maintain the constraint altitude (and not the MCP Altitude). Hutchins (1994, page 18) describes scenarios in which pilots became confused with the relationship between the MCP altitude and the FMS flightplan altitude.



The remaining altitude targets automatically selected by VNAV cover “corner cases” and are rarely observed during revenue service operations. For example, the VNAV function will automatically level the aircraft off if there is a conflict between the direction of the pilot entered MCP altitude and the phase of the flightplan. Dialing the MCP altitude below the aircraft in the climb phase of the flightplan results in an immediate level-off.. Other unusual altitude targets include; an intermediate level-off at 10, 000 feet during descent to bleed off speed to satisfy the 10K/250 restriction, and an intermediate level-off to intercept the glideslope when the aircraft has descended below the Minimum Descent Altitude (MDA) on a non-precision approach.

There are three keys to demystifying VNAV selection of targets. First a deep understanding of the FMS flightplan and how the altitude and speed constraints are used to determine targets is required. This must be coupled with knowledge of the dynamic relationship between the MCP and the FMS flightplan for selecting targets (Hutchins, 1994). Finally, the “corner case” targets of the VNAV function must be understood (Sherry & Polson, 1999).

### Automated selection of VNAV pitch/thrust control modes

Automated mode selection by the VNAV function of pitch/thrust control modes can be confusing in two ways. The most common source of confusion is the autonomous transition of the mode without pilot action (Wiener, 1988; Sarter & Woods, 1994; Vakil, Hansman, & Midkiff, 1995;. Palmer, 1995; Javaux, 1998). These “silent” mode transitions are made when VNAV detects that certain criteria have been satisfied. For

example, when the aircraft speed exceeds a threshold (typically 20 knots) above the path speed, VNAV will autonomously switch control modes from VNAV-PATH to VNAV SPEED (BASI, 1999, page 172). These thresholds are generally not annunciated on cockpit displays.

The second source of confusion is the selection of control modes made by VNAV given the circumstances of the aircraft. For example, several pilots prefer to perform descents to crossing restrictions with a fixed rate of descent (i.e. vertical speed mode). By triangulating time (or distance) to the waypoint and remaining altitude, pilots can ensure making the restriction. In certain circumstances VNAV will choose speed-on-pitch with idle thrust and request airbrakes to make the restriction (Sherry & Polson, 1999).

The key to understanding the choice of control modes made by the VNAV function is to understand the overall FMS philosophy on how descents are flown. Researchers have also proposed annunciating the intentions of VNAV (Feary, et. al., 1997; Sherry & Polson, 1999).

#### Automatic use of FMS optimum path as a reference

One of the biggest contributors to pilot confusion with VNAV is the FMS computed optimum path. The path, computed by the FMS using models of aircraft performance, takes into account the regulations and constraints of standard arrival procedures (STARs) and published approaches. The nuances of the path, such as how far way from waypoints decelerations are initiated, is non-intuitive, and worse, not displayed in the cockpit.

Compounding the complexities of the path is the issue of control. When the aircraft is capturing and maintaining the path, the aircraft altitude control is earth-referenced with the goal of placing the aircraft 50 ft above the runway threshold. This operates much like the glideslope, except that the reference beam is provided by the FMS, not a ground-based transmitter. Unlike other up-and-way control modes, the aircraft will maintain the path without drift in the presence of wind.

When the FMS optimum path is not constrained by crossing restrictions and appropriate wind entries have been made, the aircraft will descend at the desired speed with the throttles at idle. When the path is constrained or wind entries are sufficiently inaccurate, speed must be maintained using throttles (for underspeed) and airbrakes (for overspeed).

This “earth-referenced” control of altitude has been observed to confuse pilots who, on request from ATC to expedite the descent, add thrust or extend airbrakes. Because VNAV is controlling to the path, these actions simply increase or decrease speed without any effect on aircraft rate-of-descent.

The key to understanding the VNAV behavior in descent is to have full knowledge of the FMS optimum path. Several Vertical Situation Displays (VSDs) have been proposed to remedy this situation (Riley, 1997; Jacobsen, Chen, & Wiedemann, 2000, Prevot, 1999; Hutchins, 1994; Faerber, 1999). Also, pilots must understand the differences between airmass-referenced descents, such as FLCH, and earth-referenced descents on the path.

### VNAV User-Interface

The pilots user-interface provides little information on the automatic selections of the VNAV function described above. Pilots engage the VNAV function through an action (button push or knob pull/push) on the MCP. In some aircraft the button is backlit indicating that the VNAV function is engaged.

Pilots primarily monitor the behavior of the VNAV function by monitoring the trajectory of the aircraft (Javaux & Polson, submitted; Huettig, Anders, & Tautz, 1999). Under the assumption that the aircraft control surfaces and stability augmentation functions are operating normally, aircraft altitude, aircraft vertical speed, aircraft pitch, and the position of the throttle levers (or indicated thrust) are used to infer what VNAV is doing. Pilots are “surprised” by the behavior of the VNAV function when the aircraft trajectory or the thrust indicators do not match their expectations. For example, when the aircraft vertical speed fails to decrease as the aircraft approaches an assigned altitude, pilots wonder whether the VNAV function is commanding a capture to the altitude.

Secondary sources of information on VNAV include the Flight Mode Annunciation (FMA), targets on the Primary Flight Display (PFD) altitude tape and speed tape, and various MCDU pages (e.g. RTE/LEGS (or F-PLN), PROG page, CLB/CRZ/DES pages). None of these sources explicitly identify the source of targets or rationale for control modes, pilots are required to interpret this information to draw conclusions on VNAV

behavior to explain discrepancies in aircraft trajectory or thrust setting. In frequently occurring normal operation, these inferences can be made easily. In non-frequent or corner-case situations, making this kind of inference requires a deep understanding of the VNAV function and it's rules of behavior.

### Summary

The de facto philosophy in developing cockpit automation is to use automation to build intelligent agents that automate operator tasks. This philosophy recreates a number of already difficult problems with communication and intent inferencing between agents. An alternative philosophy is to use the computing power to create environments in which the operators get to be smart while using cognitive processes. This is the spirit of the guidelines developed by Billings (1997) for human-centered automation:

“To command effectively, the human operator must be involved and informed. Automated systems need to be predictable and capable of being monitored by human operators. Each element of the [cockpit] system must have knowledge of the other's intent.”

This paper examines the efficacy of the input devices and the display feedback devices of the VNAV function for creating an environment in which the pilot is “involved” and “informed.” The analysis examines how “smart” the automation makes the pilot look, rather than how “smart” the automation is. The next section describes cognitive engineering and the method for analysis of user-interfaces. This is followed by a cognitive engineering analysis of the NASA Research VNAV function. Based on the

cognitive engineering design principles, options for new user-interfaces for the VNAV function are proposed.

### COGNITIVE ENGINEERING DESIGN PRINCIPLES

Cognitive engineering is an engineering discipline conceived to provide a scientific approach to the design of interfaces between complex automated systems and their operators (Norman, 1988). Cognitive engineering specifically provides guidance for the design of automation and its user-interface to account for the performance characteristics and limitations of the human operator.

#### Cognition and Automation

Human-computer interaction can be represented by a model of two-way communication between the operator and the automation (Billings, 1997). The operator communicates their intentions to the automation using input devices provided on the automation user-interface (Figure 1). The automation acknowledges operator instructions and provides feedback of its behavior over time to the operator via the user-interface.

Norman (1988) proposed that operators of automated systems form “mental models” of the way the system behaves and use these models to guide their interaction with the system. This interaction with the automation (and much other human behavior) can be thought of as a continuous process of cyclic interaction (Monk, 1999). In the case of a pilot, to achieve a trajectory goal, the pilot performs a set of actions that lead to changes in the automation. These, in turn, cause changes in the environment. Evaluation of the state of the environment leads to reformulation of the pilot’s goals and further action, leading to a new state of the environment, and so on. This model of cyclic interaction is

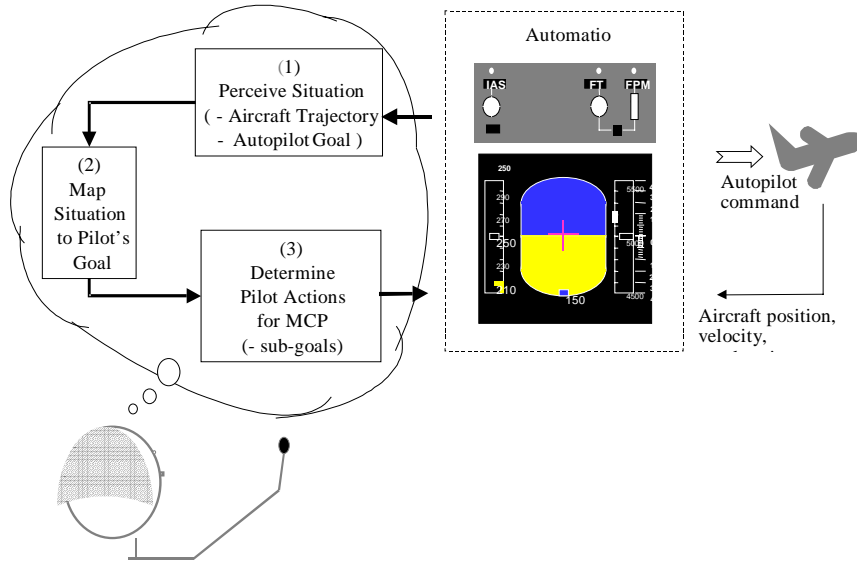

*(1) Situation, (2) goal, and (3) action sequence of pilot interaction with automation. Boxes represent knowledge required by the pilot.*

*Figure 1*

at the root of most modern models of cognition, for example; Card, Moran, & Newell's (1983) recognize-act cycle, Norman's (1988) seven stage cycle, and Anderson's (1993) ACT-R model.

This cyclic interaction is abstracted in the pictogram illustrating a pilot's interaction with the cockpit automation (Figure 1). Based on information from the environment, the pilot formulates a definition of the perceived situation (box 1). In the aviation human factors literature, building and maintaining a representation of the situation is known as "situation awareness" (see Endsley, 1995; Orsanu, 1993). The perceived situation is used to determine appropriate goals (box 2). The goals are mapped to a sequence of pilot actions on the MCP (box 3). In many cases, the sequence of pilot actions on the MCP leads to the formulation of sub-goals and sub-actions as described in hierarchical task models such as GOMS (Johns & Kieras, 1996) and OFM (Callantine & Mitchell, 1999).

### Breakdowns in Pilot-Automation Communication

Each of the cognitive activities (box 1, 2, & 3) must be trained and maintained. As is the case for all cognition, when these mental processes are complex, time-consuming, or brittle, they are subject to failure. Breakdowns in communication between operator and automation occur when:

- The design of the task and the design of *input devices* require complex, time-consuming, and/or error-prone mental processes to formulate *sequences of operator actions*. As a result, the pilot's intentions for the behavior of the automation are not always accurately conveyed to the automation.
- The design of the task and the *feedback devices* require complex, time-consuming, and/or error-prone mental processes to *infer* the behavior commanded by the automation. As a result, the pilot misunderstands the behavior commanded by the automation.

These failures may be due to the absence of appropriate knowledge in the pilot's head (box 1, 2 or 3), or when the knowledge is present, a failure in cognition (Reason, 1987; Norman, 1988).

Cognitive engineering principles define characteristics for user-interfaces that eliminate the need for pilots to hold large sets of knowledge. They provide visual cues to help the



pilot remember action sequences (e.g. prompts and labels) and identify tasks performed by the automation.

### Minimizing Operator Miscues by Design of the User-interface

There are two basic principles of cognitive engineering that minimize the rules that must be memorized to operate the automation. These principles provide for more robust operator performance and reduced training requirements.

#### Cognitive Engineering Design Principle: One Input Device – One Automation

##### Behavior

One of the biggest contributors to the need for a pilot to memorize sequences of actions are user-interfaces with buttons, or other input devices, that invoke different automation behaviors depending on the situation.

Based on an analysis of pilot tasks, the cognitive engineering design principle, *One Input Device – One Automation Behavior*, creates *one clearly labeled input device for each pilot-commanded behavior of the automation*. In this way the pilot should be able to translate an ATC instruction, or some other pilot goal, directly into an action on the appropriate input device. For example, the ATC instruction to “turn left heading two-seven-zero,” results in the pilot dialing the MCP heading knob left to 270 degrees and pushing a heading button (Note: MCP actions may vary by aircraft type). This task is always conveyed to the autopilot using this knob/button. This is the only function provided by this knob/button.

A class of pilot errors has been attributed to overloaded (or modal) input devices (Norman, 1988). These input devices invoke different automation-commanded behaviors *depending on the situation* when they are selected (Degani & Heymann, 2000; Riley, 1997). For example, the MCP vertical speed wheel on a NASA Research Autopilot was demonstrated to be a source of pilot errors (Sherry, et. al., 2000-b). This input device resulted in two different autopilot behaviors depending on the situation when it was selected. Selecting the vertical speed wheel:

- (1) when the aircraft was *outside* the capture region, commanded the aircraft to *fly to* the assigned altitude (and armed the capture)
- (2) when the aircraft was *inside* the capture region, commanded the aircraft to *fly away* from the assigned altitude (and disarmed the capture)

Frequently pilots were unaware of the dual nature of the vertical speed wheel, or could not distinguish between the dual “modes” of the wheel. As a result pilots were surprised by the behavior commanded by the autopilot. See also Palmer (1995), Degani & Heymann (2000), and NTSB (1999).

This phenomenon is compounded by automation with decision-making logic that autonomously changes the mode selected by the pilot based on the situation perceived by the automation (Billings, 1997). Sarter & Woods (1994) use the phrase “strong and silent” to characterize this phenomenon. The automation is “strong” in the sense that it has a lot of authority to determine the aircraft trajectory. It is “silent” in the sense that the

change in commanded behavior is made autonomously by the automation and is not always revealed by the user-interface to the pilot.

Cognitive Engineering Design Principle: One Automation Behavior - One

Display Configuration

User-interfaces with display configurations that represent more than one automation behavior require the operator to memorize cues from several displays to infer the behavior commanded by the automation. The cognitive engineering design principle, *One Automation Behavior – One Display Configuration*, eliminates the need to memorize display inference rules by creating *one unique display configuration for each unique behavior commanded by the automation*.

The FMA on the Primary Flight Display (PFD) provides an explicit mechanism to distinguish between the different automation commanded behaviors. For example, the NASA Research Autopilot FMA (Sherry, et. al., 2000-a) annunciates the aircraft mechanisms to control speed and altitude (<SPEED control mechanism> || <ALTIUDE control mechanism>). The annunciation of PITCH || CLB THRUST provides the pilot feedback that aircraft pitch is being controlled to maintain the selected speed, and that the aircraft is climbing to the assigned altitude with maximum thrust. (Note: the FMA on other aircraft display the parameter controlled by the thrust axis and the parameter controlled by the pitch axis instead.)

A class of pilot errors has been attributed to feedback devices that fail to distinguish between two different behaviors. For example, the FMA on the NASA Research Autopilot (Sherry, et. al., 2000-a) was demonstrated to be a source of pilot error due to the use of the same annunciation THRUST || VS for autopilot commands for:

- a climb/descent to *capture and maintain* the assigned altitude
- a climb/descent *away* from the assigned altitude
- a special case of speed protection

Frequently pilots, unaware of the other interpretations of the THRUST || VS FMA, assumed the aircraft was going to capture and maintain the assigned altitude. When the autopilot commands drove the aircraft through the assigned altitude, they were surprised. See also NTSB (1999).

#### COGNITIVE ENGINEERING ANALYSIS OF THE VNAV FUNCTION

The NASA Research VNAV function, representative of a modern air transport VNAV function, was analyzed for compliance with the two cognitive principles described above. A Situation-Goal-Behavior (SGB) model (Sherry, 1995) of the VNAV function was constructed. This model identified all of the behaviors commanded by the VNAV function. This model also identified the MCP buttons and knobs used to invoke these behaviors, and the FMA associated with each behavior. This information was used in the cognitive engineering analysis.

The Situation-Goal-Behavior (SGB) Model

The behavior commanded by the VNAV function was modeled using the Situation- Goal-Behavior (SGB) model. The SGB model, a variation of the Operational Procedure Model (Sherry, 1995), layers a semantic goal model over a formal situation-action model of a finite state machine:

$$\text{Situation} = f(\text{state of env. from system inputs}) \quad (\text{a})$$

$$\text{Goal} = f(\text{situation}) \quad (\text{b})$$

$$\text{Outputs} = f(\text{goal, functions/values}) \quad (\text{c})$$

The behavior of a system under analysis is defined by the values of the outputs over time. The outputs are generated by a three step process. The situation is determined by the conditions of the system inputs (equation a). The goal is determined by the situation (equation b). The output values are derived by executing a set of functions that are selected based on the active goal (equation c). The application of this model for cognitive engineering analysis of SGB models is described in Sherry et. al (2000-d).

SGB for VNAV

The behavior of a modern VNAV function can be defined by the combinations of commanded functions/values assigned to each of the VNAV function outputs. These outputs and their possible functions/values are listed in Table 2. These outputs reflect the targets and modes that the pilot would select on the MCP if the VNAV function were not engaged.

VNAV Outputs	Possible Functions/Values
Altitude target	<ul style="list-style-type: none"> <li>- MCP window</li> <li>- Climb Altitude Constraint</li> <li>- Cruise Flightlevel</li> <li>- Descent Altitude Constraint</li> <li>- Conflict Altitude</li> <li>- Destination Runway Elevation</li> <li>- MDA</li> <li>- Glide-slope Intercept Altitude</li> </ul>
Speed target	<ul style="list-style-type: none"> <li>- Econ Climb CAS/Mach</li> <li>- Edit Climb CAS/Mach</li> <li>- Max Angle Climb</li> <li>- Econ Cruise mach</li> <li>- Edit Cruise CAS or Mach</li> <li>- Max Endurance Cruise</li> <li>- Econ Descent CAS/Mach</li> <li>- Edit Descent CAS/Mach</li> <li>- Max Descent</li> <li>- Hold Speed</li> <li>- Return-to-Path Speed</li> <li>- Decel Speed</li> <li>- Approach Speeds</li> <li>- Landing Speed (Vref)</li> </ul>
Vertical speed target	<ul style="list-style-type: none"> <li>- MCP vertical speed window</li> <li>- current vertical speed</li> <li>- -750 fpm</li> </ul>
Speed    Altitude Control Modes	<ul style="list-style-type: none"> <li>- THRUST    HOLD</li> <li>- PITCH    CLB THRUST</li> <li>- PITCH    IDLE</li> <li>- THRUST    VS</li> </ul>

*The behavior of the VNAV function is defined by the legal combinations of functions/values for the five VNAV outputs (left column). Each row defines the VNAV function output and it's possible function/values*

*Table 2*

The SGB for the VNAV function is summarized in Table 3 (Sherry, 1994; Sherry & Polson, 1999). Each unique VNAV commanded behavior represents a combination of values for altitude target, speed target, vertical speed target, and SPEED || ALTITUDE control mode. The commanded behavior is selected to achieve a specific goal determined by the VNAV function. The SPEED || ALTITUDE FMA for each VNAV commanded behavior is also listed in Table 3. (Note: VNAV Approach behavior was not explicitly analyzed in this study. The conclusions from the analysis of the descent phase apply equally to the approach phase.)

VNAV GOAL	VNAV COMMANDED BEHAVIOR	SPEED    ALTITUDE Control Mode (FMA)
CLIMB MAINTAIN CRZ FL	Climb Maintain VNAV Alt	PITCH    CLB THRUST
	Maintain VNAV Alt	THRUST    HOLD
MAINTAIN CRZ FL	Maintain CRZ FL	THRUST    HOLD
	Climb Maintain Step CRZ FL	PITCH    CLB THRUST
	Descend Maintain Step CRZ FL	PITCH    IDLE THRUST
DESCEND TO FAF	Descend on FMS optimum path	IDLE THRUST    PATH THRUST    PATH
	Descend Return to Optimum Path from Long (Late)	PITCH    IDLE THRUST
	Descend Converge on Optimum Path from Short (Early)	THRUST    VS PITCH    IDLE THRUST
	Maintain VNAV Alt	THRUST/HOLD
	Descend Maintain VNAV Alt to Protect Speed	PITCH    IDLE THRUST
	Descend Maintain VNAV Alt, Hold to Manual Termination	THRUST    VS

*Summary of behavior of VNAV function. Behaviors are defined as unique combinations of altitude target, speed target, vertical speed target, and SPEED || ALTITUDE control modes computed by the FMS.*

*Table 3*

The commanded behaviors of the VNAV function are clustered into three VNAV function goals:

- (1) CLIMB AND MAINTAIN THE CRUISE FLIGHTLEVEL (subject to altitude, and speed constraints and limits in the Flightplan)
- (2) MAINTAIN THE CRUISE FLIGHTLEVEL (according to the profile of Cruise Flightlevels in the Flightplan)
- (3) DESCEND TO THE FINALAPPROACH FIX (FAF) (subject to altitude and speed constraints and limits in the Flightplan).

When the VNAV button is selected the VNAV function commands trajectories to satisfy the altitude and speed constraints/limits in the FMS flightplan. During the climb phase of

the flightplan, when the goal of the VNAV function is CLIMB AND MAINTAIN THE CRUISE FLIGHTLEVEL, the VNAV function commands two types of trajectories: (1) a climb (flight level change) trajectory at maximum climb thrust, or (2) a level flight (altitude hold) at the MCP altitude or flightplan altitude constraint.

During the cruise phase of the flightplan, when the goal of the VNAV function is to MAINTAIN THE CRUISE FLIGHTLEVEL, the VNAV function commands a step climb, step descent, and altitude hold behavior as determined by the profile of Cruise Flightlevels in the flightplan.

There are six behaviors commanded by the VNAV function during the descent and approach phases of the flightplan, when the goal of VNAV is to DESCEND TO THE FINAL APPROACH FIX (FAF):

1. Descend on FMS Optimum Path
2. Descend Return to Optimum Path from Long (Late)
3. Descend Converge on Optimum Path from Short (Early)
4. Maintain VNAV Altitude (i.e. altitude constraints, MCP altitude, or other VNAV altitudes)
5. Descend Open to VNAV Altitude to Protect Speed
6. Descend to VNAV Altitude, Hold to Manual Termination



The basic underlying concept of the VNAV function is that the VNAV function constructs and strives to fly an optimum path to the FAF. This path is a geographically-fixed pathway from the cruise flightlevel to the runway that is designed to optimize fuel burn and time, and takes into account the altitude crossing restrictions, and speed and time constraints (Figure 2). It is flown in much the same way as the aircraft flies a glideslope beam.

To stabilize the aircraft at the FAF the VNAV function commands trajectories to capture and maintain the path. The appropriate trajectories are determined by decision-making rules embedded in the software that take into account the position and speed of the aircraft relative to the path and other parameters. The VNAV function will automatically transition between commanded behaviors based on the situation perceived by the automation based on sensor data.

For example, when the aircraft is commanded to initiate the descent before the optimal FMS computed Top-of-Descent, the VNAV function automatically commands a VNAV Behavior to Descend and Converge on the Optimum Path, usually with a fixed rate-of-descent. The rate-of-descent is selected such that the aircraft converges on the optimum path (Figure 2).

Alternatively, when the aircraft initiates the descent beyond the Top-of-Descent, the VNAV function automatically commands a VNAV Behavior to Descend and Return to Optimum Path. This VNAV behavior commands a descent at idle-thrust. Some VNAV

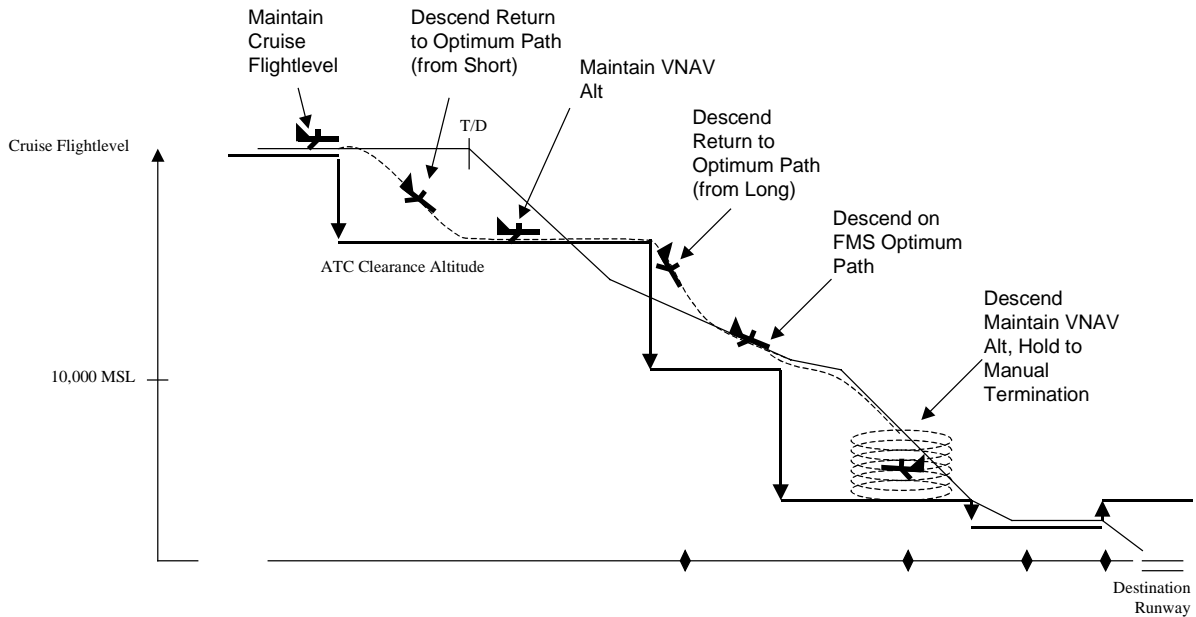

*Selecting the VNAV button invokes one of the VNAV commanded behaviors depending on the position of the aircraft relative to the FMS optimum path, the ATC clearance altitude, holding pattern at a fix, ...etc.*

*Figure 2*

functions increase the speed target to ensure convergence of the path (Figure 2). Frequently the VNAV function determines that additional drag is required to converge on the optimum path and requests extension of the air-brakes via an ND and MCDU message.

The following two sections evaluate the VNAV button and the FMA used by the VNAV function against the cognitive engineering principles described above.

### VNAV: One Button – Multiple Automation Behavior

The VNAV function violates the cognitive engineering design principle of *one button – one automation behavior* in the descent and approach phases of the flightplan. During these phases, the VNAV button invokes one of a set of possible behaviors (see Figure 3).

Furthermore, the behavior commanded by the VNAV function will autonomously change as the situation evolves.

When the VNAV button is selected during the climb and cruise phases of the flightplan, the VNAV function commands trajectories to climb, level, and descend according to the altitude and speed profile of the pilot entered flightplan. It is easy to determine and predict the behavior commanded by the VNAV function. There is only one pitch/thrust control strategy used to perform each of the climb, level, and descend trajectories. The VNAV goal and commanded trajectory can be easily distinguished by scanning the PFD altitude tape, FMA, ND, and thrust levels.

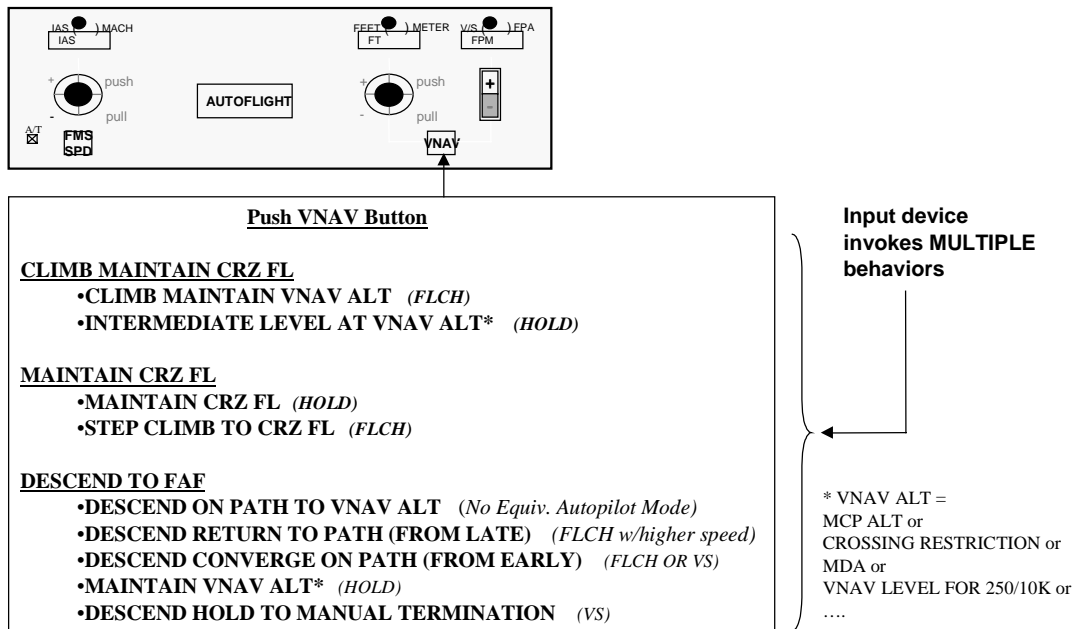

*All possible behaviors commanded by VNAV that result from selection of the VNAV button. The autopilot mode used for each VNAV behavior is included in parentheses*  
**Figure 3**

Determining and predicting the trajectory commanded by the VNAV function is more complicated when the VNAV goal is to DESCEND TO THE FAF. When the VNAV button is selected during the descent and approach phase of the flightplan, the VNAV commanded trajectory is determined by the VNAV decision-making rules and can switch behaviors rapidly during a nominal descent depending on the situation.

In cognitive engineering terms, the VNAV button is overloaded in this phase of the flightplan. Like the climb and cruise phases of the flightplan, selecting the VNAV button commands the automation to follow the altitude and speed profile of the pilot-entered flightplan. Unlike the climb and cruise phases of the flightplan, during the descent phase, the VNAV function will command one of many different trajectories for descent, depending on the relative position of the aircraft to the FMS optimum path. The VNAV function will also command level-offs and decelerations in anticipation of downstream restrictions and constraints.

In effect, the VNAV button engages a “meta-mode” (Vakil & Hansman, 1999) or “mega-mode” (Alkin, 1999). The notion of the VNAV button as a “meta-mode” is generally not understood by airline pilots (Vakil & Hansman, 1999). Several B757/767/747-400 pilots at a major U.S. airline pointed out that on the Boeing MCP the VNAV button is located adjacent to other single function buttons such as Altitude Hold and Flight Level Change. There is no visual indication that the VNAV button has meta behavior.

The overloading of the VNAV button is compounded by the autonomous decision-making of the VNAV function. Not only is it ambiguous which VNAV commanded behavior will be invoked when the VNAV button is selected, but the behavior commanded by the VNAV function will change as the situation perceived by the automation evolves (Sarter & Woods, 1994; Billings, 1997). A recent modification in the Airbus aircraft provides a triple-click aural warning when an infrequently occurring autonomous mode change occurs.

#### VNAV: Many Automation Behaviors – One Display Configuration

The VNAV function violates the cognitive engineering design principle of *one display configuration - one automation behavior*. More than one VNAV commanded trajectory will have the same display configuration of altitude targets, speed targets, vertical speed targets, and SPEED || ALTITUDE control modes. Table 2 illustrates how several different VNAV commanded trajectories share the same FMA. For example, the FMA PITCH || IDLE THRUST is used for VNAV commanded behaviors to:

- (1) Descend and Maintain Step Cruise Flightlevel
- (2) Descend and Return to Optimum Path from Long (Late) of the Path
- (3) Descend and Converge on Optimum Path from Short (Early) of the Path
- (4) Descend and Maintain VNAV Alt to Protect Speed.

Another FMA that is overloaded is THRUST || VS. This FMA is used for two different commanded behaviors: (1) Descend Converge to the Optimum Path from Short (Early) and (2) Descend Maintain VNAV Alt while Hold to Manual Termination.

This makes it difficult to determine with certainty the trajectory commanded by the VNAV function. To overcome this ambiguity, and to infer the VNAV commanded behavior, the pilot must scan the cockpit displays to determine aircraft situation relative to all of the constructs and thresholds used by the VNAV function decision-making logic. Using this information and the commanded targets and modes, the pilot uses memorized rules to infer the VNAV function goals and behavior.

Several FMA designs in operation in modern aircraft compound this phenomenon by further by introducing FMA for the VNAV function other than the basic autopilot pitch/thrust control modes. Table 4 summarizes the FMA for VNAV/PROF functions in descent on the A320 and B757. For example the B757 FMA for “climb maintain altitude” is FLCH || SPD when using the autopilot, and EPR || VNAV-SPD when using the VNAV function. The same flight level change behavior has two different FMA’s.

Not only is the pilot required to memorize a new set of FMA, but this additional set of FMA also hides the underlying philosophy of the VNAV function to capture and track the FMS optimum path. For example, the VNAV commanded behavior to Descend on the Optimum Path invokes a basic pitch control mode to track the FMS optimum path (the same way as the glideslope pitch mode tracks the ILS beam). The path control mode is not part of the basic autopilot control modes. The existence of this unique, VNAV-only, control mode, is not annunciated to the pilot. Not surprisingly, several pilots at major airlines describe the closed-loop pitch control for this VNAV behavior as “vertical speed

VNAV Goal	VNAV Behavior	A320 FMA (Equivalent FG Mode)	B757 FMA (Equivalent Autopilot Mode)
CLIMB MAINTAIN CRZ FL	Climb Maintain VNAV Alt	THR CLB   CLB (THR CLB   OP CLB)	EPR    VNAV-SPEED (FLCH    SPD)
	Maintain VNAV Alt	SPEED   ALT CST/ALT CST* (SPEED   ALT/ALT*)	SPD    VNAV-ALT (SPD    ALT HOLD)
MAINTAIN CRZ FL	Maintain CRZ FL	MACH   ALT CRZ (MACH   ALT/ALT*)	SPD    VNAV-PATH (SPD    ALT HOLD)
	Climb Maintain Step CRZ FL	THR CRZ   CLB (THR CLB   OP CLB)	EPR    VNAV-SPEED (FLCH    SPD)
	Descend Maintain Step CRZ FL	DES (THR IDLE   OP DES)	EPR    VNAV-SPEED (FLCH    SPD) THR HOLD    VNAV-SPD (THR HOLD    SPD)
DESCEND TO FAF	Descend on FMS optimum path	THR DES   DES (No Equiv. AP Mode)	THR HOLD    VNAV-PATH (THR HOLD    No Equiv. AP Mode)  SPD    VNAV-PATH (SPD    No Equiv. AP Mode)
	Descend Return to Optimum Path from Long (Late)	THR DES   DES (THR IDLE   OP DES)	EPR    VNAV-SPEED (FLCH    SPD) THR HOLD    VNAV-SPD (THR HOLD    SPD)
	Descend Converge on Optimum Path from Short (Early)	SPEED   DES (SPEED   FPA) (SPEED   VS)	EPR    VNAV-SPEED (SPD    VS) THR HOLD    VNAV-SPD (SPD    VS)
	Maintain VNAV Alt	SPEED   ALT CST/ALT CST* (SPEED   ALT/ALT*)	SPD    VNAV-ALT (SPD    ALT HOLD)
	Descend Open and Maintain VNAV Alt to Protect Speed	THR IDLE   DES (THR IDLE   OP DES)	EPR    VNAV-SPEED (IDLE    FLCH)
	Descend Maintain VNAV Alt, Hold to Manual Termination	SPEED   DES (SPEED   VS)	SPD    VNAV-SPD (SPD    VS)

*A320 and B757 FMA and for VNAV commanded behaviors. Equivalent Autopilot thrust/pitch modes are in parentheses*

*Table 4*

mode” or “flight path angle mode.” Although these are good approximations, they are incorrect and can lead to misunderstandings of the automation behavior. One consequence of this misunderstanding is that extending airbrakes when the path control mode is active will not increase the rate of descent. The rate of descent is fixed when the aircraft is tracking the ILS beam-like optimum path. Extending airbrakes simple results in an increase in thrust to maintain the selected speed in the presence of the additional drag

## DESIGN IMPROVEMENTS

Overloading the input devices and FMA/Display configuration for the VNAV function violates two basic cognitive engineering design principles. These are known causes of operator confusion and can, in part, contribute to the increased workload of the VNAV function in descent and approach. Boeing, Honeywell, NASA and airlines are working to address this issue along with other issues of ATC/FMS compatibility and vertical situation awareness. Several proposed design improvements for the VNAV user-interface, based on the cognitive engineering principles, are described below.

Separate input device to use FMS flightplan targets from input device to capture and tracks the FMS optimum path

As described above, the VNAV button selects the FMS flightplan as the source of altitude, speed, and vertical speed targets, *as well as* the pitch/thrust control mode. The behavior of the VNAV function during the climb and cruise phases of the flightplan is intuitive since there is only one trajectory that can be commanded for each segment. VNAV function behavior is not intuitive in the descent and approach phases of the flightplan. During these phases the VNAV function determines the targets and modes to satisfy the flightplan. It *also* uses decision-making logic to autonomously command a series of trajectories to capture and track the path.

The design improvement proposed is to decouple the selection of the source of altitude and speed targets, from the selection of the control modes. Figure 4 illustrates an example MCP that includes input devices (knobs) for selecting the source of the targets. A



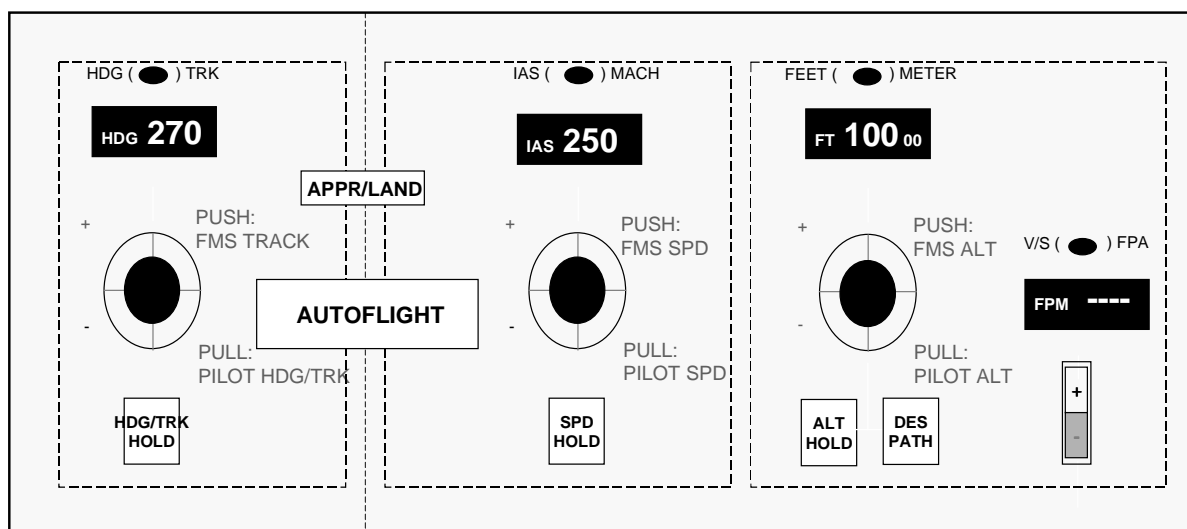

*Example of MCP designed according to the cognitive engineering principles. This MCP explicitly provides input devices to command to the FMS flightplan lateral path, altitude and speeds (push knobs). A separate input device (DES PATH button) provides the option to arm the capture and tracking of the FMS optimum path. This button has only one behavior – to capture and track the path.*

*Figure 4*

separate input device (the DES PATH button) is provided to arm the capture and tracking of the path. If the input device is selected when the aircraft is not within the capture region to the path, the “path” mode is armed, and the pilot uses traditional flight level change and vertical speed modes to converge on the path. When the aircraft achieves the capture region, the “path” mode is automatically engaged. This behavior mimics the capture and tracking of the glideslope.

#### Dynamic Label on the VNAV Button

An alternative to the decoupling the flightplan targets from the control modes, described above, is to maintain the existing user-interface with the VNAV button, but add a

dynamic label that annunciates what it will do when it is selected. Sherry, et. al., (2000-b) proposed using an LCD display on the MCP to annunciate the VNAV commanded trajectory that would be engaged when the button is selected.

This proposal allows different behaviors to be invoked from the same button depending on the situation. These different behaviors are explicitly annunciated. The downstream autonomous changes made by the automation would also be displayed in this display in the dynamic label.

#### Unique FMA for VNAV function

The FMA for the VNAV function should be unique for each VNAV commanded trajectory.

#### Annunciation of Autopilot Control Modes

One FMA design paradigm is to use the existing autopilot pitch/thrust control modes to build on the pilots existing mental model. This eliminates the need to learn two sets of FMA, one for the Autopilot and one for VNAV. This design will also explicitly annunciate VNAV specific control modes, such as the path control modes, that are not traditional Autopilot modes.

#### Annunciation of VNAV Goals/Behavior

An alternative FMA design paradigm is to annunciate the VNAV commanded behavior as described in the SGB model in Table 1 (Sherry, 1991; Sherry & Poslon, 1999). Feary

et. al (1997) demonstrated improved pilot performance ( $p < 0.03$ ) during VNAV operation with the display of the VNAV commanded behavior (instead of the control modes).

## CONCLUSIONS

This paper describes how the VNAV button on the MCP is overloaded. Selecting the button in the descent phase can command one of six possible behaviors. Furthermore, due to the decision-making logic of the VNAV function the commanded behavior will autonomously change as the situation perceived by the VNAV function changes.

The FMA used by the VNAV function is also overloaded. A given FMA represents more than one VNAV commanded behavior. These two types of overloading are well known sources of operator confusion and make it very difficult for a pilot to learn the behavior of the VNAV function simply through observation.

In addition to making the function more compatible with ATC operations, Boeing, Honeywell, NASA, and airline partners are investigating changes to the user-interface to eliminate the overloading of the VNAV button and the overloading of the FMA used by the VNAV function. As with most complex design decisions, there are several trade-offs that must take place.

### Trade-offs for Input Device Redesign

The proposal to decouple the selection of source of altitude and speed targets from the flightplan or MCP, from the selection for arming the FMS optimum path control mode creates a more operationally meaningful user-interface at the expense of adding another input device. The advantage is to unambiguously declare the existence of the path and the path control mode.

The decoupling of the control to the flightplan targets from the automatic arming of the capture and track of the path is very much the spirit of the concepts of “Managed” and “Selected” modes used on the Airbus. In the managed mode the Flight Management/Flight Guidance (FM/FG) system follows the flightplan. In the selected mode the FM/FG follows pilot entries in the Flight Control Unit (FCU) (the Airbus term for MCP).

The input device to capture and track the path invokes one VNAV trajectory as would other buttons on the display. This path mode has the same type of functionality provided by the glideslope of the Instrument Landing System (ILS) and will enable pilots to transfer their knowledge of the behavior of the ILS (available on “steam gauge” aircraft) to the behavior of the VNAV function. This operation will also match the operation of the LNAV button that arms the capture and tracking of the lateral path.

Eliminating the “off path” decision-making logic in the FMS reduces a significant amount of complex software from the FMS. This will translate to improved software integrity and possibly a reduction in the costs of development and testing.

The trade-off made to achieve this simplification of the input device is that the VNAV function will now arm for a capture of the optimum path when it is not within the capture region to the path. The pilot is now more directly involved in determining the commanded trajectory and is responsible for ensuring convergence on the path with the aid of the FMS computed intercept displayed on the ND. The pilot is also responsible for monitoring the autonomous transition from the armed state to the capture. One of the changes required would be to add the display of the armed mode on the FMA. Several Airbus and Boeing aircraft currently display armed modes, and more specifically annunciate the armed capture of the path. In addition, the automatic transition from armed state to engaged state should be brought to the pilots attention by flashing FMA and by aural indications such as the Airbus triple-click.

#### Trade-offs for Annunciation Redesign

The proposal outlined above to create an input device to choose the flightplan as the source of altitude and speed targets (as opposed to the pilot selected MCP targets) requires an annunciation in the cockpit to distinguish between the two sources. This could be accomplished by a VNAV prefix on the FMA such as on Boeing aircraft, or magenta color of PFD altitude and speed targets as on the MD-11.

There should also be unique annunciation when the path control mode is armed, captures, and tracks the path. Boeing 7XX series aircraft already annunciate VNAV-PATH for this mode. Likewise the MD-11 already annunciates PROF. Also there are several precedents for annunciation for the ILS modes.

### Aircraft in the field

For aircraft already in the field, resolving the overloading can only be achieved by training – building knowledge-in the heads of the pilots – on the behavior of the VNAV function input devices and displays. Using modern pedagogical principles (Gagne, 1985; Anderson, 1993) pilots are provided basic concepts underlying the behavior of the automation (Hutchins, 2000; Casner, 2000). These concepts are used to learn declarative rules of the detailed behavior of the automation (Javaux, 2000, Sherry, et. al. 2000-a/b). The declarative rules are then compiled into procedural knowledge through drill-and-practice on cognitive tutors (Sherry, et. al., 2000-c, Anderson, 1993).

### Automation design philosophy

The defacto philosophy of developing cockpit automation to automate operator tasks is counter to the cognitive engineering design principles that emphasize the need for pilot involvement and unambiguous feedback. Automation in the cockpit has been most successful in performing repetitive tasks of real-time control (e.g. closed-loop control of pitch axis), optimization computations (e.g. ECON speed, V-speeds), and editors and data-base (e.g. flightplan “editor” using the MCDU, ND, and the world-wide Navigation Data-base). These functions genuinely make the pilot smarter and reduce pilot workload.

Functions that automate operator tasks that are associated with the execution of the mission tend to have a high requirement for situational awareness and mission knowledge. These functions are more like smart expert systems and require high levels of

communication and interaction that may exceed the capabilities of the technologies of “glass cockpit” user-interfaces as we know of them.

Acknowledgements: This research was supported by the National Aeronautics and Space Administration (NASA) under contract GS09T00BHM0316 order ID 9T9K420A to Honeywell International Inc Commercial Aviation Government Research (CAGR) (COTR: Ev Palmer; TPC: Michael Feary) and Cooperative Agreement NCC 2-904 with the University of Colorado. Special thanks for several technical suggestions to: Steve Quarry, Dan McCrobie, Jim Martin and John Kilroy (Honeywell), Denis Javaux (Univ. Liege), Maria Consiglio (CSC), Marty Alkin (FedEx), and John Powers and Jack Rubino (UAL).

### References

- Abbott, T.S. (1995) *The evaluation of two CDU concepts and their effects on FMS training*. NASA TM-4744, January 1997, pp. 9.
- Alkin, M. (1999) personal communication.
- Anderson, J. (1993) *Rules of the Mind*. L. Erlbaum and Associated: Hillsdale, New Jersey.
- Air Transport Association. (1999). *Potential Knowledge, Policy, or Training Gaps Regarding Operation of FMS Generation Aircraft*. Automation Subcommittee, Human Factors Committee, Air Transport Association. <http://www.air-transport.org>
- BASI (1999) Advanced Technology Aircraft Safety Survey Report. *Flight Safety Digest: Special Issue*. Flight Safety Foundation June – August, 1999 pages 137 – 216. Available at <http://www.basi.gov.au/sprog/advtek.htm> (9/00)

Billings, C. E. (1997). *Aviation automation: The search for a human-centered approach*.

Mahwahad, NJ: Lawrence Erlbaum.

Callantine, T.J., & C.M. Mitchell (1999) *GT-CATS: Tracking Operator Activities in*

*Complex Systems*. NASA/TM-1999-208788.

Card, S.K., T.P. Moran, & A. Newell (1983) *The psychology of human-computer*

*interaction*. Lawrence Erlbaum: Hillsdale, N.J.

Casner, S. (2000) Pre-hire autoflight training curricula. Autoflight Industry Workshop

2000, Denver, Colorado. June 7-8, 2000.

Degani, A., & M. Heymann (2000) Some formal aspects of human-automation

interaction. In *Proceedings HCI-Aero 2000*, Toulouse, France, Sept 27-29, 2000.

Endsley, M. R. (1995) Measurement of Situation Awareness in Dynamic Systems.

*Human Factors*, Vol 37, No. 1 pages 65-84.

Eldredge, D., S. Mangold, & R.S. Dodd. (1992) *A review and discussion of flight*

*management incident reported to the Aviation Safety Reporting System*. Final Report

DOT/FAA/RD-92/2. Battelle/U.S. Department of Transportation.

Faerber, Robert A. (1999) Improving the Interface: Alternative Display Formats and

Interface Techniques for Enhancing the Human Interface to an Advanced Graphical

Flight Management System. In *Proceedings of the Tenth International Symposium on*

*Aviation Psychology*. Columbus, OH (May 3-6). 19-25.

Federal Aviation Administration. (1996). *The interface between flightcrews and modern*

*flight deck system*. FAA human factors team. Federal Aviation Administration.

Available at <http://www.faa.gov/avr/afs/interface.pdf>



Feary, M., M. Alkins, E. Palmer, L. Sherry, D. McCrobie, P. Polson (1997) Behavior-based vs. system-based training and displays for automated vertical guidance. Proceedings *Ninth International Aviation Psychology Symposium Conference*, Columbus, OH.

Funk, K. (1997) *Aircraft accident rates: Conventional vs. advanced technology*. Available on the Flight Deck Automation Issues website at <http://flightdeck.ie.orst.edu/FDAI/hullLossRates.html> (11/29/00)

Gagne, R.M. (1985) *The Conditions of Learning and Theory of Instruction: 4<sup>th</sup> Edition*. New York: Hold, Rinehart, and Winston.

Huettig, G., G. Anders, & A. Tautz (1999) Mode awareness in a moder glass cockpit: Attention allocation to mode information. In *Proceedings of the 10<sup>th</sup> International Conference on Aviation Psychology*, Columbus, Ohio.

Hutchins, E. & B. Holder (2000). Conceptual Models for Understanding an Encounter with a Mountain Wave. In *Proceedings HCI-Aero 2000*, Toulouse, France, Sept 27-29, 2000.

Hutchins, E. (1994) An integrated mode management interface for training. Training for automation workshop, NASA-Ames Research Center, Moffet Field, CA.

Jacobsen, A., Chen, S., & Wiedemann, J. (2000). Vertical situation awareness display. Paper presented at the Situation Awareness on the Flight Deck: Avionics and Systems Miniconference, *Royal Aeronautical Society*, London, March 23, 2000.

Javaux, D. (2000). Assessing and Understanding Pilots Knowledge of Mode Transitions on the A340-200/300. In *Proceedings of HCI-AERO'2000*, 27-29 September, Toulouse: France.

- Javaux, D. (1998). Explaining Sarter & Woods classical results: The cognitive complexity of pilot-autopilot interaction on the Boeing 737-EFIS. In N. Levenson and C. Johnson (Eds.) *Proceedings of the 2<sup>nd</sup> Workshop on Human Error, Safety, and Systems Development*, Seattle, WA. April 1-2, 1998.
- John, B. & D. Kieras (1996) Using GOMS for User-interface design and evaluation: Which technique ?” *ACM transactions on Computer-Human Interaction* V 3, N 4. Pgs 287-319.
- Mangold, S.J. & Eldredge, D. (1995) Flight management system information requirements. In R.S. Jensen (Ed.), *Proceedings of the Eighth International Aviation Psychology Symposium Conference*, Columbus: Ohio State University Press.
- McCrobie, D., M. Feary, L. Sherry, M Alkin, P. Polson, E. Plamer, N. McQuinn (1997) *Aiding Vertical Navigation Understanding*. Honeywell ATSD, 21111 N. 19<sup>th</sup> Ave., Phoenix, AZ, 85036.
- Mumaw, R. (2000) personal communication.
- Monk, A. (1999) Modelling cyclic interaction. *Behavior & Information Technology*, Vol. 18, No. 2. Pgs 127-139.
- NASA (2000) *Center TRACON Automation System (CTAS)*. Available at <http://www.ctas.arc.nasa.gov/> (9/14/00)
- Norman, D. A. (1988) *The Design of Everyday Things*. Doubleday: New York, N.Y.
- NTSB (1999) Safety Recommendation. A-99-39 through 44
- Orsanu, J. M. (1993) Decision-making in the Cockpit. In *Cockpit Resource Management*, edited by E. Winer, B. Kanki, and R. Helmreich, Academic Press, San Diego, Ca.

- Palmer E. (1995) Oops, it did n't arm: A case study of two automation surprises." In proceedings *Eighth International Symposium on Aviation Psychology*, Columbus, OH, April, 1995. Pgs. 227-232.
- Prevot, T (1998) A display for managing the vertical path: An appropriate task with inappropriate feedback. Proceedings HCI-Aero International Conference on Human-Computer Interaction in Aeronautics, Montreal, Canada.
- Polson, P.G. & D. Javaux (submitted) A theoretical analysis of the skills required to operate a modern autopilot. Submitted *11<sup>th</sup> International Conference on Aviation Psychology*, Columbus, Ohio. March 2001.
- Polson, P.G., S. Irving, & J.E. Irving (1994) *Applications of formal methods of human computer interaction to training and the use of the control and display unit*. System Technology Division, ARD 200 DOT/FAA.
- Reason, J. (1987) The psychology of mistakes: A brief view of planning failures. In J. Rasmussen, K. Duncan, & J. leplat, eds, *New Technology and Human Error*. John Wiley: New Yor, N.Y. Pgs 45-52.
- Riley, V. (1998) Cockpit control language: A pilot centered avionics interface. Proceedings HCI-Aero International Conference on Human-Computer Interaction in Aeronautics, Montreal, Canada.
- Sarter, N.B., D.D. Woods, & C.E. Billings (1997) Automation surprises. In G. Salvendy, editor, *Handbook of Human Factors and Ergonomics*. John Wiley & Sons, 2<sup>nd</sup> edition.
- Sarter, N.B. & D.D. Woods. (1994). Pilot Interaction With Cockpit Automation II: An experimental study of pilots mode awareness of the flight management system. *The International Journal of Aviation Psychology*, 4 (1), 1-28.

- Sarter, N.B. & D.D. Woods. (1992). Pilot Interaction With Cockpit Automation I: Operation Experiences with the Flight Management System. *The International Journal of Aviation Psychology*, 2 (4), 303-321.
- Sherry, L., M. Feary, P. Polson, & E. Palmer (2000-a) What's it doing now ? Taking the covers off autopilot behavior. Honeywell Publications C69-5370-13
- Sherry, L., M. Feary, P. Polson, & E. Palmer (2000-b). Why won't it take that ? MCP control device invokes more than one autopilot behavior. Honeywell Publications C69-5370-14
- Sherry, L., M. Feary, P. Polson, & E. Palmer (2000-c). Autopilot tutor: Building and maintaining autopilot skills. Honeywell Publications C69-5370-15. In *Proceedings of HCI-AERO'2000*, 27-29 September, Toulouse: France.
- Sherry, L., M. Feary, P. Polson, & E. Palmer (2000-d). Formal method for the analysis of two types of automation surprises. Honeywell Publications C69-5370-16.
- Sherry, L.& P.Polson (1999) Shared models of flight management systems vertical guidance. In *The International Journal of Aviation Psychology – Special Issue: Aircraft Automation*. L. Erlbaum: N.Y.
- Sherry, L. (1995) A formalism for the specification of operationally embedded reactive systems. In proceedings of the *International Council of System Engineering*, St. Louis, Missouri.
- Sherry, L. (1994) *Apparatus and method for controlling the vertical profile of aircraft*. U.S. Patent No. 5,337,982, Phoenix, AZ.: Honeywell
- Sherry, L. (1991) Method and Apparatus for the annunciation of VNAV modes. Honeywell invention disclosure.

Transport Canada (1997) *Report of the RNAV Task Force FMS SID/STAR Working Group: FMS Arrivals at Ottawa and Calgary*. Transport Canada Publication AARN-1225-3-13.

Vakil, S. S. & R.J. Hansman (1999) Approaches to mitigating complexity-driven issues in commercial autoflight systems. In pre-proceedings *Human Error, Safety, and System Development*, Liege, Belgium. June 7-8, 1999.

Vakil, S. S., Hansman, R. J., & Midkiff, A. H. (1995). Impact of vertical situation information on vertical mode awareness in advance autoflight systems. *AIAA/IEEE Digital Avionics Systems Conference*. Nov. 6-9, 1995, Cambridge, MA.

Wiener, E. (1988) Cockpit Automation. In E.L. Wiener & D.C. Nagels (Eds.), *Human factors in aviation* (pp 433-461). San Diego, CA: Academic.

Wiener, E. R. Chute, & J, Moses (1999) Transition to glass: Pilot training for high technology transport aircraft. In *Flight Safety Digest Special Issue, Glass Cockpits: Pilot's Perspective*. Flight Safety Foundation, June-August, 1999.

Woods, D.D., & N.B. Sarter. (1998). *Learning from automation surprises and "going sour" accidents: Progress on human-centered automation*. Final Report, NASA Ames Research Center, Cognitive Engineering in Aerospace Applications, NCC 2-592.

Woods, D.D., Johannesen, L., Cook, R., N. Sarter (1994) Behind human error: Cognitive systems, computers, and hindsight. *Wright Patterson Air Force Base, Dayton, O.H.:* CSERIAC.