

# A Collision Avoidance Model Based on the Lobula Giant Movement Detector (LGMD) Neuron of the Locust

Sergi Bermúdez i Badia  
Institute of Neuroinformatics  
ETH – University of Zurich  
Winterthurerstrasse 190  
Zurich, CH 8057 Switzerland  
E-mail: sergi@ini.phys.ethz.ch

Paul F.M.J. Verschure  
Institute of Neuroinformatics  
ETH – University of Zurich  
Winterthurerstrasse 190  
Zurich, CH 8057 Switzerland  
E-mail: pfmjv@ini.phys.ethz.ch

**Abstract-** In insects we can find very complex and compact neural structures that are task specific. These neural structures allow them to perform complex tasks such as visual navigation, including obstacle avoidance, landing, self-stabilization, etc. Obstacle avoidance is fundamental for successful navigation, and it can be combined with more systems to make up more complex behaviors. In this paper we present a model for collision avoidance based on the Lobula Giant Movement Detector (LGMD) cell of the Locust. This is a wide-field visual neuron that responds to looming stimuli and that can trigger avoidance reactions whenever a rapidly approaching object is detected. Here we present result based on both an offline study of the model and its application to a flying robot.

## I. Introduction

For collision avoidance some times it is wrongly thought that the distance to objects should be exactly known, extracted from the visual flow or assessed using other techniques. Less obvious is to avoid obstacles without information on distances to surfaces, ego motion or without a previous knowledge of the environment. However, collision avoidance does not require explicit information about distances. In other words, there should be some way to extract relative distances, sizes and orientation of the different objects in the environment to accomplish this task. All this information can be directly assessed using optic flow [6,8,11]. Therefore, there should be specific connections from the visual receptor cells to the motor system (optomotor connections) to perform this task. For this reason some learning methods and genetic algorithms had been used before to learn this mapping [5].

The visual system of insect shows a very particular hierarchical structure where the receptive fields progressively expand. At the top of this hierarchy we find, so called, matched filters tuned to one particular feature of the visual

world. The most important layers in this architecture are the Lamina (pre-processing of the input signal) and the Lobula layer (wide-field neurons including those for the detection of expansion within the visual field) [3-4][14-16].

An approaching object, such as a predator, is characterized by an increasing retinal size. A wide-field visual neuron called LGMD is located in the Lobula layer of the Locust nervous system, and this cell responds to approaching stimulus by increasing its firing rate [3-4][14-15]. Neurons detecting looming stimuli have been characterized also in moths [17], and flies [7]. Two models have been used to explain the behavior of these cells, one making use of a pre-synaptic competition between excitation and inhibition [9-8]; and one that involves a multiplication within the neuron itself in order to explain the non-linearity of some of the responses of this cell to different stimuli [3].

Here we present an alternative model based on our earlier simulation studies [9-8]. In recent publications [3] it has been suggested that the behavior of the LGMD neuron cannot be explained in terms of the interaction between pre- and postsynaptic excitation and inhibition as proposed in [9-8]. As a consequence the authors suggest that the LGMD neuron itself is capable in performing a non-linear operation. However, one problem of neuronal non-linearities is that a biophysical implementation of it has so far not been identified. Hence, the question is how we can account for these nonlinear response properties without assuming them to be mirrored in the LGMD neuron. We solve this problem by assuming that the detection of expanding objects results from the integration of the inputs of correlators as opposed to a pre-synaptic competition between excitatory and inhibitory inputs. We show that our model can account for the reported nonlinear response properties of the LGMD neuron and can perform reliable obstacle detection when embedded in the control structure of a flying robot.

## II. Model

The model is implemented on a P.C. under Linux O.S., using the IQR421 neural simulator software. This software environment allows the user to define complex biologically realistic neuronal models that can be interfaced to real-world devices.

Our collision avoidance system is insect based, and consequently, it models several processes performed in different layers of the insect visual system. Some important processes for our purpose occur in the first layers of the insect visual system (lamina) and involve the normalization of the image (logarithmic compression of the response of the photoreceptors) and a subsequent contrast enhancement (center/surround antagonism) [16]. This first process provides the system with robustness to dynamic changes in the luminance level and it also reduces the redundancy in the input image due to the contrast or edge enhancement.

### A. Reichardt Correlation

Looking at the behavior shown by insect optomotor responses, the formal “correlation model” of the local movement detectors located in the fly visual system was proposed long ago [12]. These elementary motion detectors are located in the Lobula Plate layer of the insect visual system (VS and HS Tangential Cells). They are tuned to respond to motion in one preferred direction and their output is proportional to the optical flow perceived in that direction [1-2]. Just a few further elaborations have to be performed in order to allow the correlation model to reflect the specific features of the fly’s motion detection system [2].

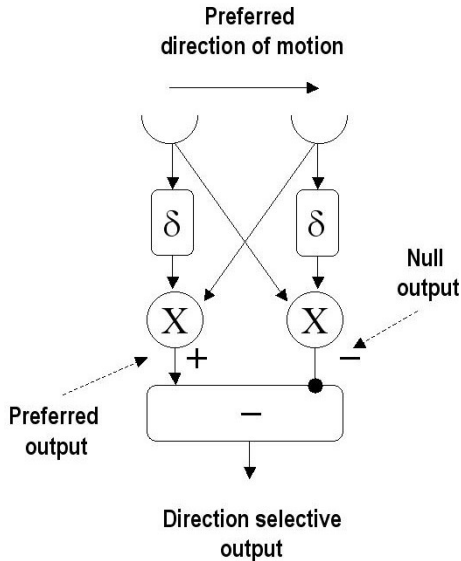

Fig. 1. Basic structure of the Reichardt correlation detector, where  $\square$  represents a delay, X the multiplication operation and  $-$  the subtraction operation.

The Reichardt correlation is the core of our model (fig. 1) [12]. It takes two input signals with a fixed angular separation. Each of these time-independent inputs passes through a linear delay filter  $\delta$  before being multiplied by the other non-delayed signal. The results of the two correlations are subtracted to produce a single output. In this example an object moving to the right will produce a positive output whereas an object moving to the left will produce a negative output.

### B. LGMD model

The LGMD cell is a wide-field neuron that responds to looming stimuli and is a well studied feature of the locust’s nervous system [3-4][14-15]. The LGMD increases its firing rate in response to both the velocity of the approaching object and the distance to this object. In earlier work we have presented a model of the LGMD that was tested on wheeled robots exploiting the motion of the visual stimuli. Here we present a further elaboration of this model that is based on the Reichardt correlation detector and that is able to work in real 3D environments.

Recent studies have suggested that the LGMD can perform a multiplication of different inputs, in particular the angular velocity,  $\theta'$ , and angular size,  $\theta$ , of an approaching object [3]. This implies that these features are extracted in real time in the lobula or previous layers of the visual system of the Locust. Hence, this hypothesis implies a much more complex structure in the visual system of the Locust than has so far been observed and assumes that the LGMD can perform non-linear operations. In contrast our implementation is based on correlation in the layers pre-synaptic to the LGMD neuron (Reichardt correlator based EMDs) and only requires the LGMD to integrate these inputs. In addition, our model represents a totally different approach respect to the one proposed some time ago by Rind and Blanchard [9-8] that solely relies on the competition between pre-synaptic excitation and a delayed inhibition.

In our model (fig. 2), the input image is expanded and passes through a delay filter, generating what is going to be a prediction of the next input image. This prediction is multiplied by a new input image in the next time step. The correlation between the prediction and current image give us a parameter of the expansion of the image whereas on the other branch, the correlation will give a parameter of contraction. Both values will be subtracted and calculated for every pixel in the image. The addition of all the results of these correlations will be proportional to the expansion in the visual field.

Since more activity in the input image implies a higher probability to have random noise in the image resulting in the detection of spurious correlations, the overall activity level of

the input image is taken into account with a feed-forward inhibition. Also the LGMD is subject to such an inhibition, where this inhibitory projection seems to signal the overall motion activity in the visual field [3]. At this point in our model the LGMD integrates these different feedforward components. When this integrated input exceeds a threshold the LGMD will signal a looming stimulus, i.e. pending collisions, and can trigger an avoidance reaction.

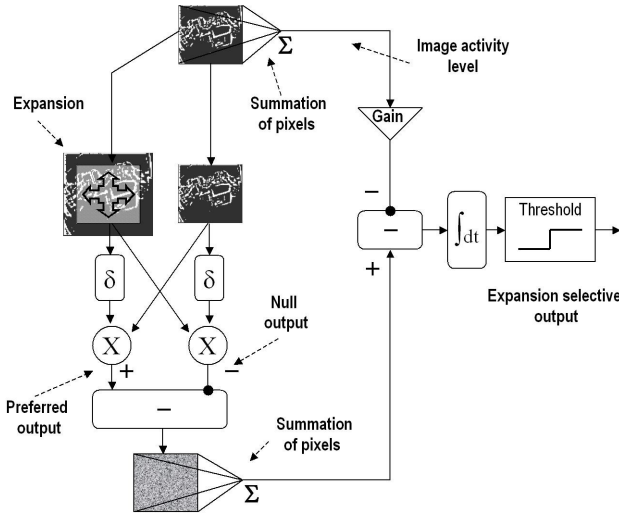

Fig. 2. Implementation of the LGMD model, making use of Reichardt correlator [12], where  $\delta$  represents a delay,  $X$  the multiplication operation and  $-$  the subtraction operation. This model responds to looming stimulus in the visual field taking into account that the strength of the response will depend on the global activity level of the image (feed forward inhibition), and then this response is integrated over time and thresholded.

After the offline characterization of the model, we have applied it to a blimp-based robot in order to evaluate the performance in the real world. For these tests, two cameras are mounted on the front part of the robot providing input to two visual processing streams both feeding into their own LGMD neuron. This allows the model to detect the looming stimulus on each side of the visual field. Whenever a train of spikes is produced by one of the simulated LGMD neurons, either left or right, it triggers an avoidance reaction in the opposite direction, performing a turn over an angle that is defined by the strength of the response of the LGMD. If both LGMD neurons respond at the same time to an approaching stimulus, as it can happen in corners, the avoidance reaction involves a straight reverse movement.

### III. Results

Some experiments and test have been performed in order to characterize the performance and sensitivity of the model. In a first stage, a stand-alone camera approaching a wall has been used to test and characterize the model. The wall is

presented with random black-filled squares on a white background as visual cues, and a distance of 3.5 meters is chosen for the approaching maneuver. Five successive tests are performed for a range of speeds.

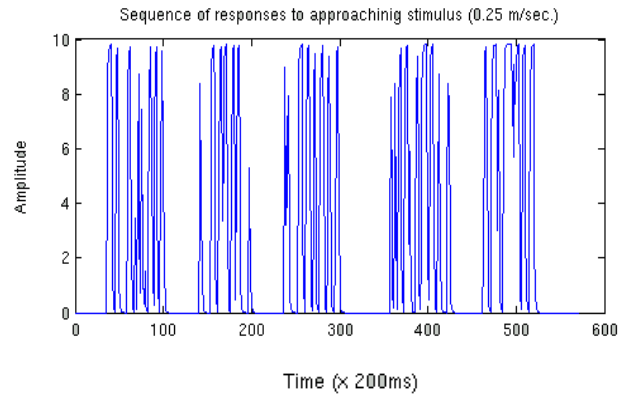

Fig. 3. Responses of the LGMD model to five approaching and releasing maneuvers at 0.25 m/s.

The responses of the model (fig. 3) shows strong activity and high firing rates during the approaching maneuvers whereas no activity is shown during releasing. This trace is similar to real recordings of the LGMD and it shows that this model can be used to prevent collisions, but probably its responses vary depending on the speed of approach.

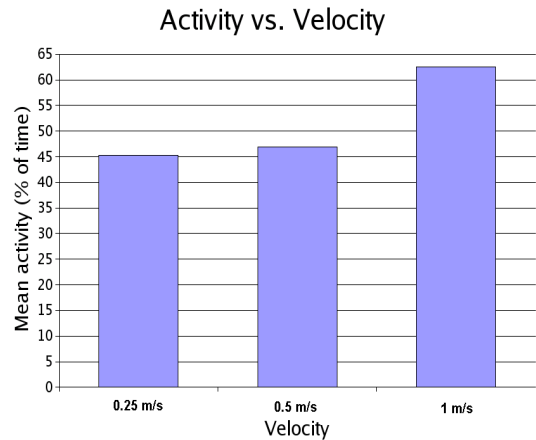

Fig. 4. Mean activity of the LGMD responses relative to the duration of the stimulus. Five tests are performed for every speed.

Looking and the mean activity time (spikes/second) of the response at different speeds (fig. 4), an exponential increase of the activity is observed when increasing the speed. However, the total amount of spikes occurring during the approaching maneuver is reduced for higher speeds (fig. 5). This implies that the firing rate (spikes/seconds) of our model increases with speed of approach as is observed in the real LGMD cell. Recordings of this neuron show the same exponential pattern, which is the main argument in favor of the multiplicative hypothesis [3]. However, here we have

presented a model that does not need to calculate either the angular size ( $\theta$ ) or the angular velocity ( $\theta'$ ) of the approaching object in order to explain its non-linear behavior. In this case it can be explained as an emergent property arising from the integration of EMD inputs with an global image derived gain control signal.

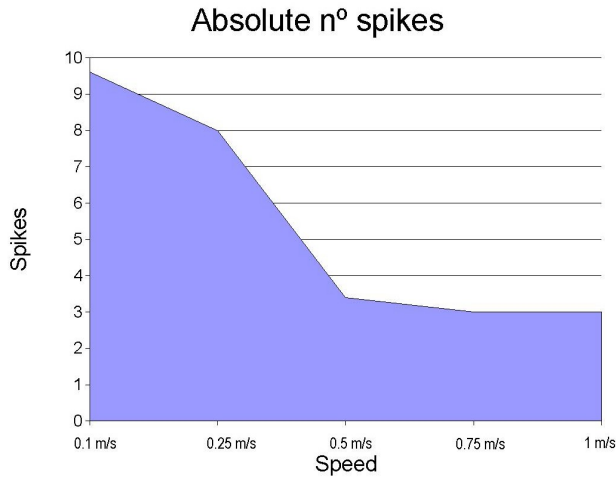

Fig. 5. Mean of the absolute occurrences of spikes during the approaching maneuver. Five tests are performed for every speed.

The last test before applying it to our robot was to look at the distance at which the collision could be detected, and therefore, successfully avoided. For the same range of speeds, the responses have been analyzed to find out the distance at which the first event of spike occurred (fig. 6). This analysis shows a later response for high speeds, being in the worst case at a distance around 1.75 m away from the wall at 1 m/s, a velocity unreachable for a normal ground robot.

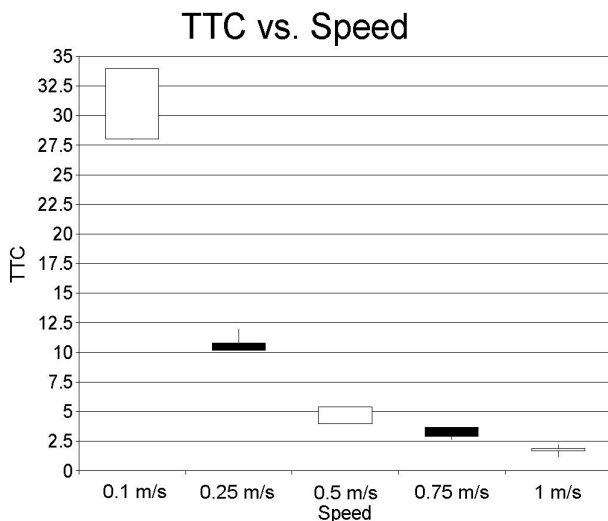

Fig. 6. Time To Contact (TTC) with the wall at which the first event of spike occurred. Five tests are performed for every speed.

To test the robustness and performance of the model in a real 3D environment, we have applied it to a blimp-based robot. This model of the LGMD cell is used to trigger the avoidance reactions whenever our flying robot is approaching an object or a wall [4][14-15]. Thus, using a pair of cameras pointing to both left and right sides, and using two identical processing streams dedicated to each camera, the avoidance reaction can be triggered in the opposite direction of the looming stimulus.

As observed in the LGMD cell of the Locust, our model responds as a wide-field visual neuron that starts to spike whenever it is stimulated by a looming stimulus, but it is spiking more often, increasing its activity as it gets close to the object. Therefore, the avoidance maneuver is triggered when the model responds with high activity.

The flying robot showed a successful avoidance behavior in our test room (4 x 4 meters) where a number. of random black squares were placed on the walls to provide visual cues. The collision is detected within 1 m. and 2.7 m., being far enough from the wall to perform a successful avoidance maneuver.

#### IV. Conclusions

A new model for the LGMD is proposed using a new approach [7-9][17-18] that is based on the Reichardt correlators. This model responds with high activity to looming stimuli and shows a null response for contraction of the image. This property makes it highly appropriate to prevent collisions.

The model has been characterized for a range of speeds, detecting an imminent collision for all the cases, and at least 1.75 meters away from the object at the highest speed (fig. 6). This behavior allows us to detect collisions at a prudent distance from the obstacle, being a good candidate to be applied in relatively fast robots or where the environmental conditions do not permit a fast response (underwater or aerial vehicles, etc).

An important aspect of our model is that it explains key features of the LGMD while not assuming that it performs non-linear operations on high-level features of the image such as angular size ( $\theta$ ) or the angular velocity ( $\theta'$ ) [3]. Given that our model is simpler we would argue that provides a better reflection of biological reality.

This version of our model can, however, not explain all behaviors of the LGMD such as its independence from source position and direction of the looming stimulus [3-4]. However, we believe that this problem can be addressed by expanding the front-end processing of our model. Other behaviorally similar models have been recently proposed [7], but never applied, in order to explain the behavior of the

saccades of the fruit fly *Drosophila Melanogaster*, that are triggered in order to avoid collisions and a similar approach has been followed using a terrestrial robot [13]. However, our model is unique in the sense that we have shown that the principles underlying the LGMD detection system can both match the physiology of this system and reliably control a flying vehicle providing further support for this approach. The presented model is consistent with the current fly and locust physiology and behavior studies [7,13].

#### Acknowledgement

The authors would like to thank Pawel Pyk for his help in developing the UAV platform. This is a work supported by the AMOTH project, and was supported by the E.U. This research is supported by the European community and BBW (Grant "A Fleet of Artificial Chemosensing Moths for Distributed Environmental Monitoring (AMOTH)" to PFMJV, funded under the IST Future and Emerging Technologies Programme (IST-2001-33066, project website <http://www.amoth.org/>).

#### References

- [1] Egelhaaf. "On the neural basis of figure ground discrimination by relative motion in the visual system of the fly. I. Behavioral constraints imposed on the neuronal network and the role of optomotor system". *Biol. Cybern.* 52:123-140, 1985.
- [2] Egelhaaf and Borst, "Motion computation and visual orientation in flies". *Comp. Biochem. Physiol.* 104A:659-673, 1993.
- [3] Fabrizio Gabbiani, Holger G. Krapp, Christof Koch & Guilles Laurent. "Multiplicative computation in a visual neuron sensitive to looming". *Nature*, vol. 420, pp. 320-324, 2002.
- [4] Hatsopoulos, N., Gabbiani, F. & Laurent, G. "Elementary computation of object approach by a wide-field visual neuron". *Science* 270, 1000-1003, 1995.
- [5] Jean-Christophe Zufferey, Dario Floreano, Matthijs van Leewen, and Tancredi Merenda. "Evolving Vision-Based Flying Robots". In *Proceedings of the 2<sup>nd</sup> International Workshop on Biologically Motivated Computer Vision*, LNCS 2525, pp. 592-600, Berlin, Springer-Verlag. (BMCV'2002).
- [6] Koenderink, J.J. and van Doorn, A.J. (1977). How an ambulant observer can construct a model of the environment from the geometrical structure of the visual inflow. In *Kybernetik*, ed. G.Hauske & E.Butenand, pp.224-247. Munich:Oldenburg, 1977.
- [7] Lance F. Tammemo and Michael H. Dickinson. "The influence of visual landscape on the flight behavior of fruit fly *Drosophila Melanogaster*". *The Journal of Experimental Biology* 205, pp. 327-343, 2002.
- [8] Lee DN. The optic flow field: the foundation of vision. *Philos Trans R Soc Lond B Biol Sci.* 8;290(1038):169-79, 1980.
- [9] Mark Blanchard & Paul F.M.J. Verschure. "Using a mobile robot to study locust collision avoidance responses." *International Journal of Neural Systems*, vol. 9, No. 5 405-410, 1999.
- [10] Mark Blanchard, F. Claire Rind, Paul F.M.J. Verschure. "How accurate need sensory coding be for behaviour? Experiments using a mobile robot". *Neurocomputing* 38-40, pp. 1113-1119, 2001.
- [11] Nakayama K, Loomis JM. Optical velocity patterns, velocity-sensitive neurons, and space perception: a hypothesis. *Perception*;3(1):63-80, 1974.
- [12] Reichardt, Autocorrelation, *A principle for the evaluation of sensory information by the central nervous system.* In: *Sensory communication* (Rosenblith WA, ed) pp 303-317. New York: MIT Press-Wiley, 1961.
- [13] Reid R. Harrison. "A Low-Power Analog VLSI Visual Collision Detector". In *Proceedings of the Neural Information Processing Systems 2003*, December 2003.
- [14] Rind, F.C. & Simmons, P.J. "Orthopteran DMCD neuron: a reevaluation of responses to moving objects. I. Selective responses to approaching objects". *J. Neurophysiol.* 68, 1654-1666, 1992.
- [15] Schlotterer, G. R. "Response of the locust descending movement detector neuron to rapidly approaching and withdrawing visual stimuli". *Can. J. Zool.* 55, 1372-1376, 1977.
- [16] V. Braitenberg, "Patterns of projections in the visual system of the fly. I. Retina-Lamina projections". *Experimental Brain Research*, vol. 3, pp. 227-298, 1967.
- [17] Wicklein M, Strausfeld NJ. "Organization and significance of neurons that detect change of visual depth in the hawk moth *Manduca Sexta*". *J. Comp. Neurol.* 1999.