

A Comparative Study of Phase Offset Disposition Sinusoidal Pulse Width Modulation (POD-SPWM) and Symmetrical Pulse Width Modulation Switching Techiques for Generalized Current Source Multilevel Inverter(MCSI)

Nik Fasdi Nik Ismail¹, Nasrudin Abdul Rahim², Siti Rohani Sheikh Raihan³, Yusuf Al-Turki⁴

^{1,2,3,4} Faculty of Electrical Engineering, Universiti Teknologi MARA, 40000 Shah Alam, Selangor, Malaysia

^{1,2,3} UM Power Energy Dedicated Advanced Centre (UMPEDAC) , Universiti Malaya, Level 4, WismaR&D, Kuala Lumpur, Malaysia

⁴Department of Electrical and Computer Engineering, College of Engineering and Renewable Energy Group, King Abdul Aziz University, Jeddah, Arab Saudi

Article Info

Article history:

Received Oct 9, 2017

Revised Dec 20, 2017

Accepted Jan 11, 2018

Keywords:

ABSTRACT

This paper presents a comparison between two switching techniques namely Phase Offset Disposition Sinusoidal PWM (POD-SPWM) and Symmetrical PWM switching for a generalized current source multilevel inverter (MCSI) topology. One of the advantages of MCSI is it can reduce the total harmonic distortion (THD) at the output load current with a sinusoidal current waveform. In this paper, the generalized MCSI with the different levels has been developed with Matlab@simulation software in order to study the performance of the two switching schemes for the operation of the MCSI. From the simulation results, POD-SPWM switching technique can give better THD results compare to symmetrical switching technique

Copyright © 2018 Institute of Advanced Engineering and Science.
All rights reserved.

Corresponding Author:

Nik Fasdi Nik Ismail,
Faculty of Electrical Engineering,
Universiti Teknologi MARA, 40000 Shah Alam, Selangor,
Malaysia
Email: nikfasdi@yahoo.com

1. INTRODUCTION

An inverter converts direct current (DC) to alternating current (AC). Inverters can be classified into two topologies; voltage source inverters (VSI) and current source inverters (CSI). Both of the topologies have their own advantages and disadvantages compare to others. Today, most of the published researches are on VSI compare to CSI in term of publications and research works. This is because VSI topologies have more common advantage in power converter applications such as device voltage ratings, higher efficiency and more practical in industrial applications [1]–[8]. However, CSI is very popular with their special features as compare to VSI such as the reliability of the input inductor, short circuit current protection and inherent boost characteristics[9]–[12]. This paper focused on Multilevel Current Source Inverter (MCSI) with two different switching schemes. The switching scheme namely Phase Disposition PWM and symmetrical PWM has been used to generate five-level output current for the MCSI. In the study, the simulations for 5-level, 7-level and 9-level of MCSI have been conducted in MATLAB/Simulink software.

2. MULTILEVEL CURRENT SOURCE INVERTER (MCSI)

The generalized MCSI topology in Figure 1 was introduced in [13], and for the five-level output MCSI is shown in Figure 2. This five-level circuit contains of four couples of parallel complementary (PWM) switches which are S_5S_6 , S_7S_8 , S_3S_4 and S_1S_2 . In the MCSI, the intermediate current must be equally distributed among all branches in order to have a current balancing. If the current are not equally shared, the output current waveform become unbalanced, thus the total harmonic distortion (THD) for the output load current becomes higher.

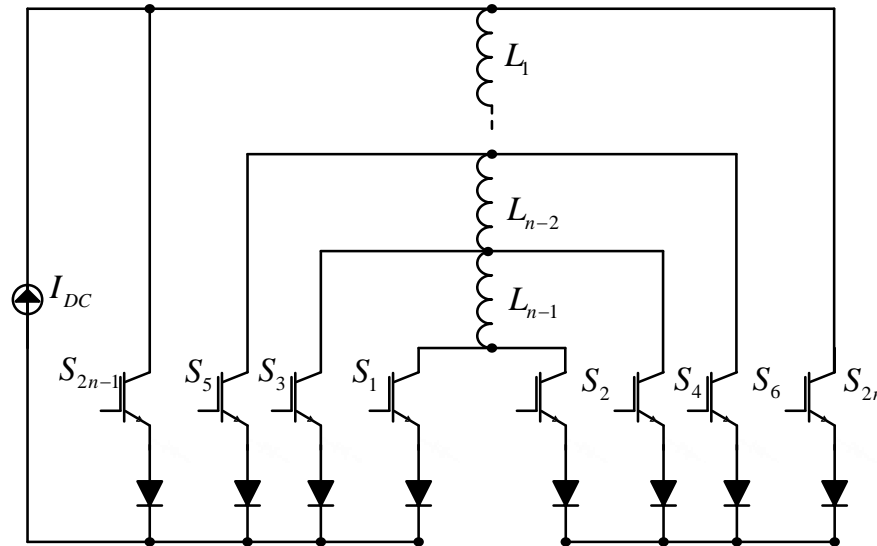

Figure 1: General MCSI N-Level

Therefore, the switching control scheme used in the MCSI needs to ensure the current balancing between the intermediate inductor current levels. In order to study the effectiveness of these two types of switching control scheme namely POD SPWM and Symmetrical PWM, the comparison was made between the switching strategies.

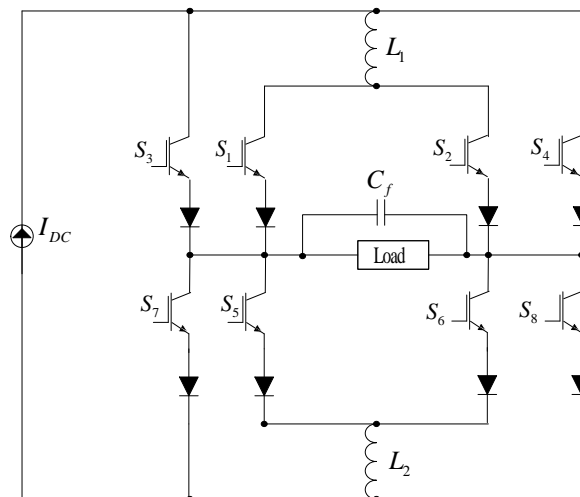

Figure 2: Five-Level MCSI

Table 1 shows the switching sequence for 5, 7 and 9 levels of CSI. In n-levels of CSI, $2(n-1)$ of switches are needed. Hence, for 5-level of MCSI, 8 switches are needed, whereas 12 switches are needed for

7-level and 16 switches need for 9-level of MCSI. Therefore, it can be conclude that, for the n-level of MCSI requires of 2 (n-1) numbers of switches.

Level	ON Switches	Output Current	Level	ON Switches	Output current
1	S ₄ , S ₆	0	1	S ₅ , S ₇	0
2	S ₂ , S ₄ , S ₅ , S ₇	I	2	S ₂ , S ₄ , S ₆ , S ₇ , S ₉ , S ₁₁	I
3	S ₂ , S ₄ , S ₆ , S ₇	I/2	3	S ₂ , S ₄ , S ₆ , S ₈ , S ₉ , S ₁₁	2I/3
4	S ₁ , S ₄ , S ₆ , S ₈	-I/2	4	S ₄ , S ₆ , S ₈ , S ₉	I/3
5	S ₁ , S ₃ , S ₆ , S ₈	-I	5	S ₃ , S ₆ , S ₈ , S ₁₀	-I/3
			6	S ₁ , S ₃ , S ₅ , S ₇ , S ₁₀ , S ₁₂	-2I/3
			7	S ₁ , S ₃ , S ₅ , S ₈ , S ₁₀ , S ₁₂	-I

(a) Switching sequences for 5 levels MCSI

(b) Switching sequences for 7 levels MCSI

Level	ON switches	Output current
1	S ₈ , S ₁₀	0
2	S ₂ , S ₄ , S ₆ , S ₈ , S ₉ , S ₁₁ , S ₁₃ , S ₁₅	I
3	S ₂ , S ₄ , S ₆ , S ₈ , S ₁₀ , S ₁₁ , S ₁₃ , S ₁₅	3I/4
4	S ₂ , S ₄ , S ₇ , S ₉ , S ₁₃ , S ₁₅	I/2
5	S ₂ , S ₇ , S ₉ , S ₁₅	I/4
6	S ₁ , S ₈ , S ₁₀ , S ₁₆	-I/4
7	S ₁ , S ₃ , S ₇ , S ₉ , S ₁₄ , S ₁₆	-I/2
8	S ₁ , S ₃ , S ₅ , S ₈ , S ₁₀ , S ₁₂ , S ₁₄ , S ₁₆	-3I/4
9	S ₁ , S ₃ , S ₅ , S ₇ , S ₁₀ , S ₁₂ , S ₁₄ , S ₁₆	-I

(c) Switching sequences for 9 levels CSI

Table 1: a) Switching sequences for 5 levels CSI, b) Switching sequences for 7 levels CSI, c) Switching sequences for 9 levels CSI.

2.1. Phase Offset Disposition (POD-SPWM) with a single carrier

In general the POD-SPWM is a simple and general switching technique for multilevel inverters. This technique uses a single sinusoidal reference signal with four carrier signals. These signals need to be compared in order to produce gating signals for the inverter as shown in Figure 3 for a 5-level MCSI. From the figure, the output SPWM is set to be “ON” state when the reference signal is higher than the carrier signal and in the “OFF” state when lower than the carrier signals. The multilevel carrier signal can be either in the form of phase shifted or level shifted as presented in [10], [9], [14]–[16]. Usually, in n-level of current source inverter, one sinusoidal signal will be compared with (n-1) number of carrier signal, but in the purposed POD-SPWM technique, only one carrier signal and one sinusoidal signal will be used to generate the PWM pulses for the inverter. The generations of switching signals in order to generate different level of output current are shown in Figures. 4(a) to 4(d).

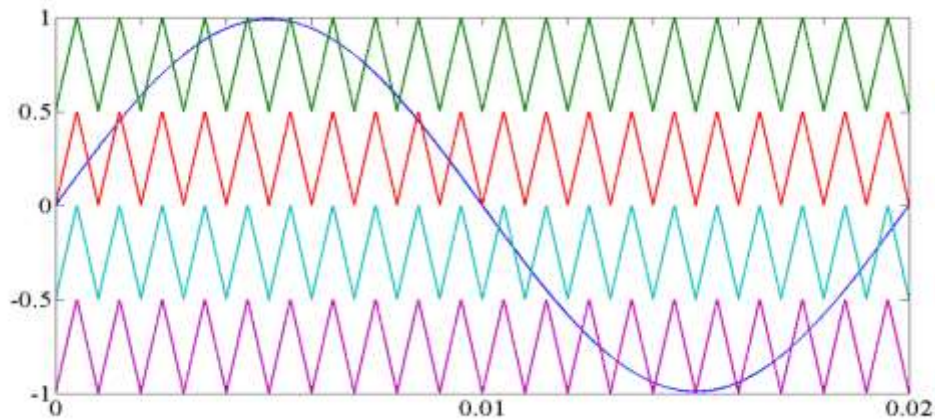

Figure 3. Operating Principle of SPWM Technique for 5-level MCSI

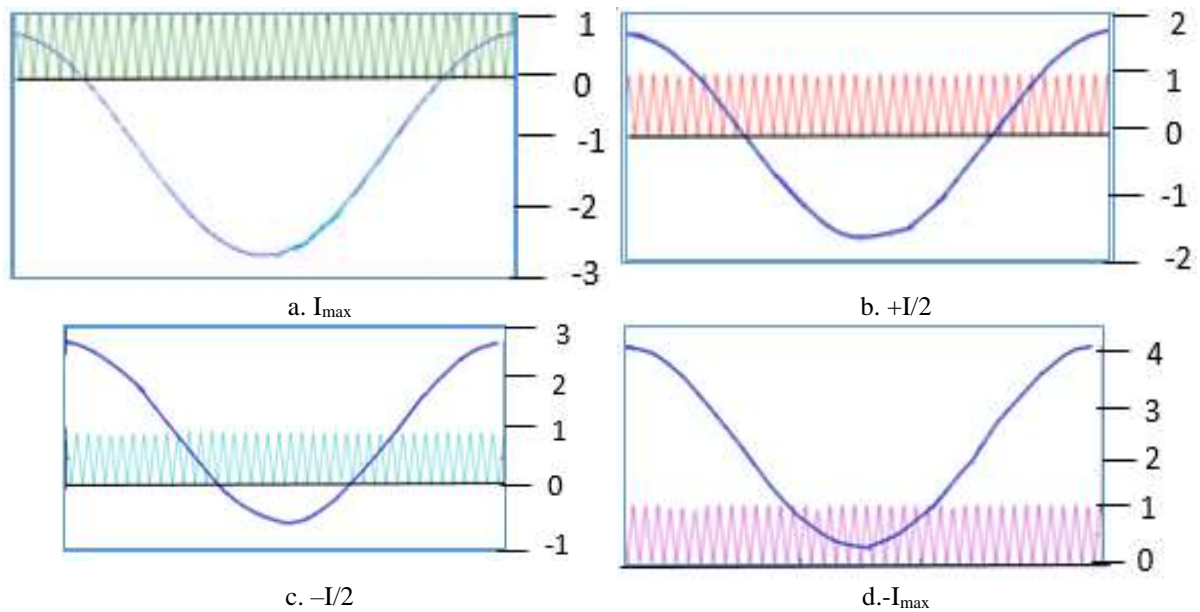

Figure 4. (a), (b), (c), (d): Operation of Single Carrier Signal POD-SPWM in 5-level MCSI

2.2. Symmetrical PWM Switching Signal

This technique compares a sinusoidal signal with a single line signal. In this study, the amplitude of the single line is fixed at 0.5 at all periods. The comparison between sinusoidal waveform and single line produces a PWM signals as shown in Figure 5. This switching signals is considered as symmetrical signal because produces switching signal which is always 50% of duty cycle.

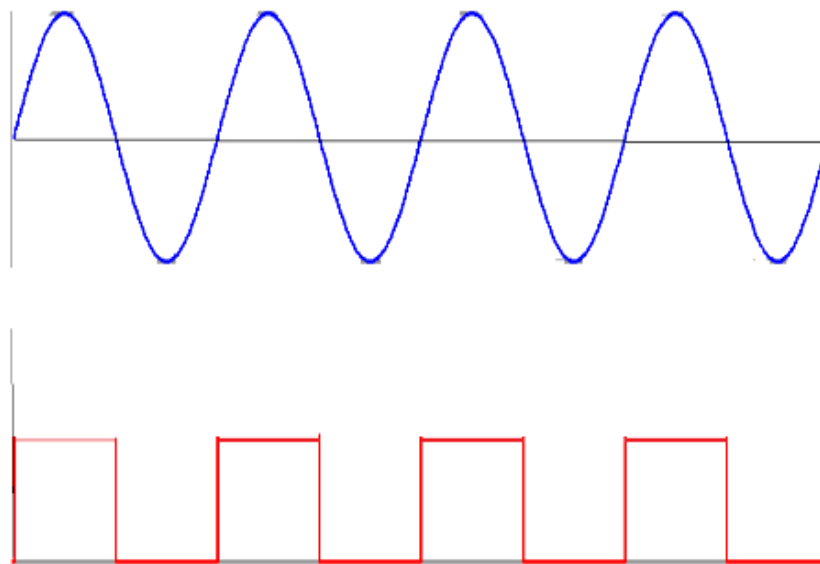

Figure 5. Operating Principle of Symmetrical PWM Switching Signals

3. RESULT AND DISCUSSION

In this section, the simulation results for 5-level, 7-level and 9-level of MCSI are discussed. Theoretically, by increasing the number of output current levels, it will lead to the reduction of THD of output current and as a result a small size of filter is needed. For the simulation parameters, the maximum

current is set to be 20A and the switching frequency is 5 kHz. Each power switch in the simulation consists of the IGBT with the series diodes. The circuit simulation for the 5-level MCSI are shown in Fig. 6.

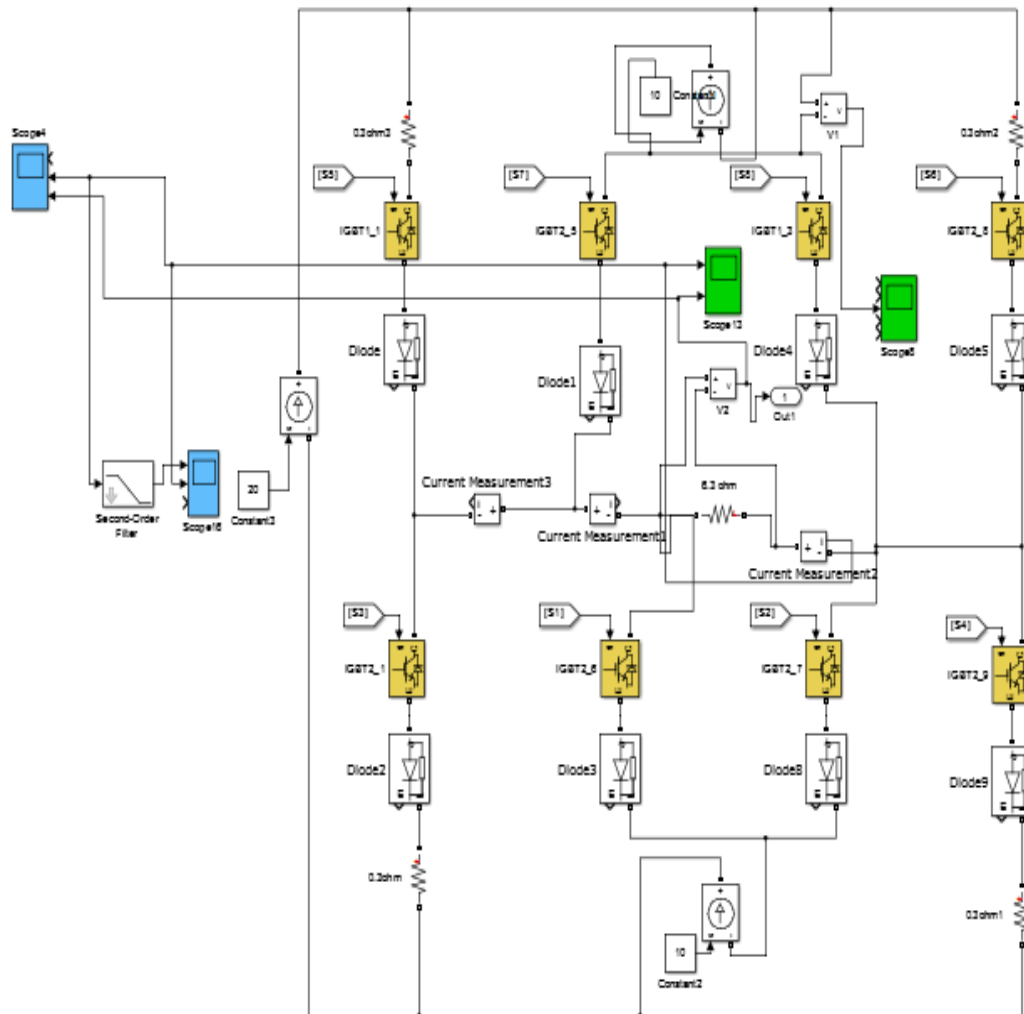

Figure 6: Five-level MCSI

Table 3 : Comparison of Output Current Waveform for 5, 7 and 9 Levels of CSI With and Without Filter (a) POD-SPWM Waveform, (b) Symmetrical PWM Switching Signal Waveform

Level	Output Current Waveforms	
	With Filter	Without Filter
5	 <p>(a) POD-SPWM</p>	 <p>(a) POD-SPWM</p>
	 <p>(b) Symmetrical PWM</p>	 <p>(b) Symmetrical PWM</p>
7	 <p>(a) POD-SPWM</p>	 <p>(a) POD-SPWM</p>
	 <p>(b) Symmetrical PWM</p>	 <p>(b) Symmetrical PWM</p>
9	 <p>(a) POD-SPWM</p>	 <p>(a) POD-SPWM</p>
	 <p>(b) Symmetrical PWM</p>	 <p>(b) Symmetrical PWM</p>

Table 3 shows the output current waveform for 5, 7 and 9 levels of MCSI for the POD-SPWM and Symmetrical PWM Switching Signals with and without filter. From the results, the waveform becomes more sinusoidal with the increment of number of levels. However, between the POD-SPWM and Symmetrical switching schemes, the POD-SPWM can generate a good quality of output current waveforms with a low THD values as shown in Table 4. The THD for 7 and 9 levels are less than 5% for the POD-SPWM. The POD-SPWM is able to generate more number of pulses signals compared to Symmetrical PWM Switching Signal[17]. As a result, it can reduce the THD value at the output current.

Table 4: Comparison percentage of THD between POD-SPWM and Symmetrical PWM Switching Signals

Level	% THD of POD- PWM, %	% THD of Symmetrical PWM
5	6.72	13.45
7	4.24	6.37
9	3.72	4.57

4. CONCLUSION

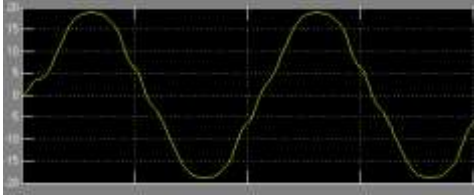
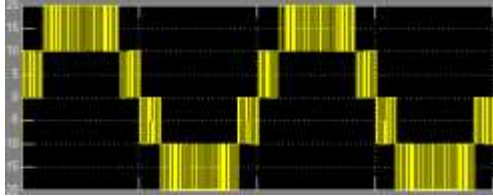
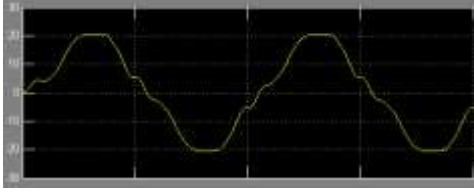
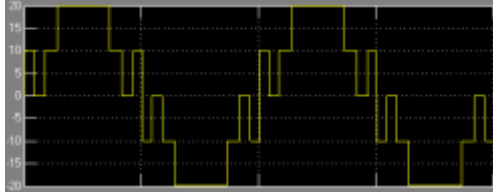
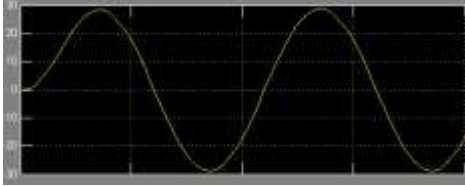
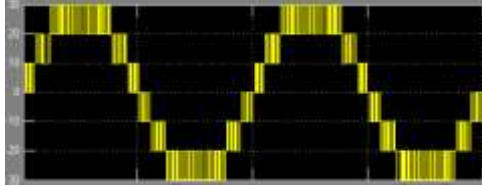
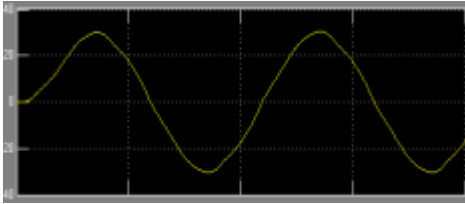
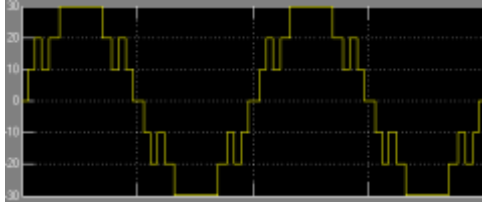
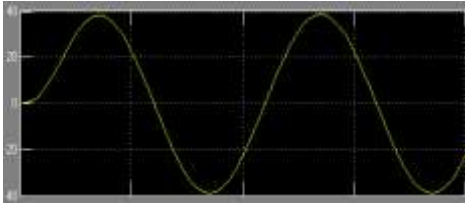
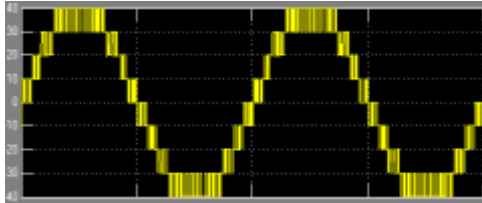
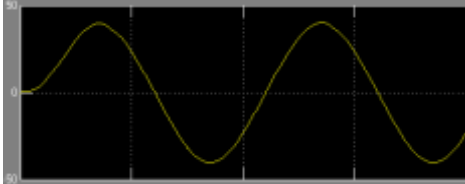
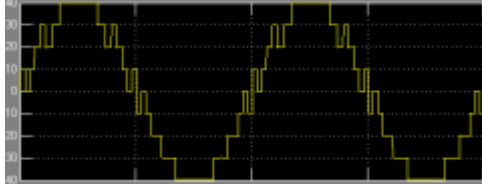
In this study, a comparison between POD-SPWM with a single carrier and Symmetrical PWM switching scheme are presented. The operation for the proposed converter has been simulated with MATLAB/Simulink. The proposed switching schemes for both techniques are able to produce the desired output current levels. From the analysis by increasing the number of output levels of MCSI, from 5-level to 9-level, the percentage of Total Harmonic Distortion (THD) are significantly reduced. However, the POD-SPWM switching technique can give better output results compare to the Symmetrical PWM technique with low % of THD for similar level of output current.

ACKNOWLEDGEMENT

The authors appreciate financial support by the University Technology Mara (UiTM) through grant of 600-IRMI/DANA5/3/LESTARI (0022/2016).

REFERENCES

- [1] W. Choi, P. N. Enjeti, and J. W. Howze, "Development of an Equivalent Circuit Model of a Fuel Cell to Evaluate the Effects of Inverter Ripple Current," *Ina. Power Electron. Conf. Expo. 2004. APEC '04. Ninet. Annu. IEEE*, vol. 0, no. C, pp. 355–361, 2004.
- [2] S. A. Azmi, K. H. Ahmed, S. J. Finney, and B. W. Williams, "Comparative analysis between voltage and current source inverters in grid-connected application," *Renew. Power Gener. (RPG 2011), IET Conf.*, pp. 1–6, 2011.
- [3] J. R. Espinoza, L. A. Moran, and J. I. Guzman, "Multilevel Three Phase CSI based AC Drive for High Performance," *2005 IEEE 36th Power Electron. Spec. Conf.*, pp. 2553–2559, 2005.
- [4] M. R. Aghaebrahimi, A. H. Kazemian, and M. A. Shamsinejad, "A new Combined Circuit for DC-DC Converter with the Ability to Reduce the Input Current's Ripple and with High Voltage Gain for Fuel Cell Applications," *Ind. Electron. Soc., IECON 2016 - 42nd Annu. Conf. IEEE*, pp. 1208–1213, 2016.
- [5] H. Kesraoui, H. Echeikh, A. Iqbal, and M. F. Mimouni, "Five-Phase Permanent Magnetic Synchronous Motor Fed by Fault Tolerant Five Phase Voltage Source Inverter," *Int. J. Electr. Comput. Eng.*, vol. 6, no. 5, pp. 1994–2004, 2004.
- [6] B. Jyothi and M. V. G. Rao, "Performance Analysis of 3-Level 5-Phase Multilevel Inverter Topologies," *Int. J. Electr. Comput. Eng.*, vol. 7, no. 4, pp. 1696–1705, 2017.
- [7] V. Saravanan, M. Aravindan, V. Balaji, and M. Arumugam, "Z Source Inverter Topologies-A Survey," *Bull. Electr. Eng. Informatics*, vol. 6, no. 1, p. 12, 2017.
- [8] N. Devarajan and A. Reena, "Reduction of switches and DC sources in Cascaded Multilevel Inverter," *Bull. Electr. Eng. Informatics*, vol. 4, no. 3, pp. 186–195, 2014.
- [9] M. P. Aguirre, L. Calvino, and M. I. Valla, "Multilevel current-source inverter with FPGA control," *IEEE Trans. Ind. Electron.*, vol. 60, no. 1, pp. 3–10, 2013.
- [10] B. S. Dupczak, M. L. Heldwein, and A. J. Perin, "Space vector modulation strategy applied to interphase transformers-based five-level current source inverters for electric propulsion," *Power Electron. Appl. (EPE 2011), Proc. 2011-14th Eur. Conf.*, pp. 1–10, 2011.
- [11] S. Koenig and G. Herold, "Twelve-pulse multilevel current source inverters for fundamental frequency switching schemes," in *Proceedings of International Conference on Harmonics and Quality of Power, ICHQP, 2014*, pp. 788–792.
- [12] D. Sha, Y. Xu, J. Zhang, and Y. Yan, "Current-Fed Hybrid Dual Active Bridge DC – DC Converter for a Fuel

- Cell Power Conditioning,” vol. 64, no. 8, pp. 6628–6638, 2017.
- [13] S. Daher, The Ricardo Silva, and F. Antunes, “Multilevel Current Source Inverter - The Switching Control Strategy For High Power Application,” *Ind. Electron. Control. Instrumentation, 1996., Proc. 1996 IEEE IECON 22nd Int. Conf.*, pp. 1752–1757, 1996.
- [14] M. P. Aguirre, M. A. Engelhardt, J. M. Bracco, and M. I. Valla, “Current balance control in a multilevel current source inverter,” *Proc. IEEE Int. Conf. Ind. Technol.*, pp. 1567–1572, 2013.
- [15] Z. Bai, Z. Zhang, and Y. Zhang, “A generalized three-phase multilevel current source inverter with carrier phase-shifted SPWM,” *PESC Rec. - IEEE Annu. Power Electron. Spec. Conf.*, pp. 2055–2060, 2007.
- [16] Suroso and T. Noguchi, “New generalized multilevel current-source PWM inverter with no-isolated switching devices,” *Proc. Int. Conf. Power Electron. Drive Syst.*, pp. 314–319, 2009.
- [17] Z. Zhang and B. T. Ooi, “Multi-modular current-source spwm converters,” *Power Electron. Spec. Conf. 1992. PESC '92 Rec. 23rd Annu. IEEE*, vol. 1, pp. 561–568, 1992.