

**NASA CONTRACTOR
REPORT**



NASA CR-2772

0061365



TECH LIBRARY KAFB, NM

NASA CR-2772

LOAN COPY: RETURN TO
AFWL TECHNICAL LIBRARY
KIRTLAND AFB, N. M.

**A COMPARISON OF A LABORATORY
AND FIELD STUDY OF ANNOYANCE
AND ACCEPTABILITY OF
AIRCRAFT NOISE EXPOSURES**

Paul N. Borsky

Prepared by
COLUMBIA UNIVERSITY
Franklin Square, N.Y.
for Langley Research Center



NATIONAL AERONAUTICS AND SPACE ADMINISTRATION • WASHINGTON, D. C. • FEBRUARY 1977



0061365

1. Report No. NASA CR-2772		2. Government Accession No.		3. Recipient's Catalog No.	
4. Title and Subtitle A COMPARISON OF A LABORATORY AND FIELD STUDY OF ANNOYANCE AND ACCEPTABILITY OF AIRCRAFT NOISE EXPOSURES				5. Report Date February 1977	
				6. Performing Organization Code	
7. Author(s) Paul N. Borsky				8. Performing Organization Report No.	
9. Performing Organization Name and Address Columbia University Noise Research Unit Franklin Square, NY				10. Work Unit No.	
				11. Contract or Grant No. NASA Grant NSG-1164	
12. Sponsoring Agency Name and Address National Aeronautics and Space Administration Washington, DC 20546				13. Type of Report and Period Covered Contractor Report	
				14. Sponsoring Agency Code	
15. Supplementary Notes Langley Technical Monitor: Clemans A. Powell, Jr. Topical Report					
16. Abstract A total of 216 subjects who were representative of residents living in close, middle and distant areas from JFK Airport were included in a field interview and laboratory study. In the laboratory, judgments were made of simulated aircraft noise exposures of comparable community indoor noise levels and mixes of aircraft. Each group of subjects judged the levels of noise typical for its distance area. Four different numbers of flyovers were tested, less than average for each area, the approximate average, the peak number, or "worst day" and above peak number. The major findings are: 1) that the reported integrated field annoyance is best related to the annoyance reported for the simulated approximate "worst day" exposure in the laboratory; 2) annoyance is generally less when there are fewer aircraft flyovers, and the subject has less fear of crashes and more favorable attitudes toward airplanes; 3) beliefs in harmful "health effects" and misfeasance by operators of aircraft are also highly correlated with fear and noise annoyance; 4) in direct retrospective comparisons of number of flights, noise levels and annoyance, subjects more often said the "worst day" laboratory exposures appeared more like their usual home environments; 5) subjects do not expect an annoyance-free environment - about half of all subjects say they can accept an annoyance level of 5-6 from a possible annoyance range of 0-9. About 28% say they can live with an annoyance intensity of 7 and only 5% say they can accept the top scores of 8-9.					
17. Key Words (Suggested by Author(s)) Aircraft Noise Laboratory Study Field Study Noise Pollution Number of Events Subjective Reactions				18. Distribution Statement Unclassified - Unlimited Subject Category 45	
19. Security Classif. (of this report) unclassified		20. Security Classif. (of this page) unclassified		21. No. of Pages 73	22. Price* \$4.25

PREFACE

This report is a team effort of the Columbia University Noise Research staff. Thelma Weiner was in charge of field interviewing and coding operations. Paula Tito and Babette Stack handled all subject contacts. Michael Harges was in charge of the TV-Audio laboratory tapes and operations. Frances Gach, as office manager, took care of the administrative details involved in an interdisciplinary research project. Dr. Philip Cheifetz and Joseph Carlino were in charge of statistical analyses.



TABLE OF CONTENTS

	<u>Page</u>
Preface	iii
List of Tables	vi
List of Figures	vii
I. Introduction	1
II. Experimental Design	5
A. Overall Research Objectives	5
B. Acoustic Characteristics of Laboratory Experiment	5
C. Experimental Environment	10
D. Subjects to be Tested	13
E. Procedures Used in Experiment	13
III. Findings	19
A. Representativeness of Sample	19
B. Description of Aircraft Noise Exposures	19
C. Reported Annoyance with TV Interference in the Field Interview and Laboratory Sessions	26
D. Correlation Analyses of Reported Annoyance in Field and Laboratory Environments	43
E. The Effects of Reported Feelings of Fear and Number of Aircraft Flyovers on Annoyance	46
F. Relationships of Selected Attitudes and Personal Variables on Laboratory and Field Annoyance Responses	53
G. Reported Retrospective Comparisons of Laboratory Stimuli and Home Environments	53
H. Annoyance and Acceptability Judgements	56
I. Relationships Between 5 and 10-Point Annoyance Scales	61
J. Summary	64
Bibliography	66

LIST OF TABLES

		<u>Page</u>
Table 1.	Peak dBA Noise Levels Used in Experiment	6
2.	Number and Types of Flyovers for each Stimulus Tape	7
3.	Order of Aircraft Flyovers for Stimulus Tape Recordings	8
4.	Minute Intervals from start of Session of Aircraft Flyovers for Stimulus Tape Recordings	9
5.	Completion Rates of Assignments	21
6.	Outcome of Invitations to Participate in Laboratory Study	22
7.	Comparative Characteristics of Subjects and Non-Participants	23
8.	Percent Distribution of Monthly Arrivals on Runway 22L During the Evening Hours 7:00 PM - 9:59 PM by Type of Aircraft	24
9.	Frequency Distribution of the Number of Daily Arrivals on Runway 22L During the Evening Hours	25
10.	Mean Annoyance Reports with TV Interference in the Field Interview and Laboratory	44
11.	Correlations between Field Interview and Laboratory Reports of Annoyance with Interference of TV by Airplane Noise	47
12.	Two-Way Analysis of Variance Fear by Number Flyovers	49
13.	Mean Laboratory Annoyance Responses by Fear of Aircraft Crashes	50
14.	Mean Laboratory Annoyance Responses by Number of Flyovers	50
15.	Reported Mean TV Annoyance in Field Survey by Fear Groups of Residents	51
16.	Reported Total Airplane Noise Annoyance in Field Survey by Fear Groups of Residents	51
17.	Duration in Seconds of Flyovers above Ambient	52
18.	Computed L_{eq} Values for Each Laboratory Segment	52
19.	Correlations between Personal Variables and Annoyance Responses for all Subjects	54
20.	Reported Ways Aircraft Noises are Believed Harmful to Health	54
21.	Laboratory Stimuli Conditions Compared to Usual Home Conditions	55
22.	Chi-Square Tests of Distributions of Answers to Judgements of Laboratory and Home Exposures	57-58
23.	Reports of Annoyance and Acceptability Reported in Laboratory Judgements	59
24.	Cross Tabulation of Field Reports of Overall Annoyance with Airplane Noise on 10 and 5-Point Scales	63

LIST OF FIGURES

	<u>Page</u>
Figure 1. Laboratory Living Room	11
2. Diagram of Sound Playback System	12
3. Location of Columbia University Research Facility and Approach Path to Runway "22L"	15
4. Reaction Sheet	20
5. Indoor Noise Spectra of 707 Maximum dBA Level on Approach	27
6. Indoor Noise Spectra of 747 Maximum dBA Level on Approach	28
7. Indoor Noise Spectra of 727 Maximum dBA Level on Approach	29
8. Indoor Noise Spectra of DC-10 Maximum dBA Level on Approach	30
9. Indoor dBA Levels of 707 1.9 km from Touchdown - Time History	31
10. Indoor dBA Levels of 747 1.9 km from Touchdown - Time History	32
11. Indoor dBA Levels of 727 1.9 km from Touchdown - Time History	33
12. Indoor dBA Levels of DC-10 1.9 km from Touchdown - Time History	34
13. Indoor dBA Levels of 707 4.0 km from Touchdown - Time History	35
14. Indoor dBA Levels of 747 4.0 km from Touchdown - Time History	36
15. Indoor dBA Levels of 727 4.0 km from Touchdown - Time History	37
16. Indoor dBA Levels of DC-10 4.0 km from Touchdown - Time History	38
17. Indoor dBA Levels of 707 8.4 km from Touchdown - Time History	39
18. Indoor dBA Levels of 747 8.4 km from Touchdown - Time History	40
19. Indoor dBA Levels of 727 8.4 km from Touchdown - Time History	41
20. Indoor dBA Levels of DC-10 8.4 km from Touchdown - Time History	42
21. Comparison of Annoyance and Acceptability Judgments	59

A COMPARISON OF A LABORATORY AND FIELD STUDY
OF ANNOYANCE AND ACCEPTABILITY OF AIRCRAFT
NOISE EXPOSURES

I. Introduction

Following the end of World War II, the civil air transportation industry grew at an unusually rapid rate. With the introduction of jet aircraft, the number of larger faster and more powerful airplanes grew at an even more rapid pace. These developments created an unexpected hostile reaction from many communities near civil airports. In 1952, following two crashes at Elizabeth, N.J., adjacent to Newark Airport, a spontaneous protest from the nearby communities forced the temporary closing of the airport. At the request of the NACA and the Academy of Sciences, these unexpected community reactions were investigated by Columbia University staff and a pilot study revealed that prior to the crashes, as the volume of air traffic of larger and larger airplanes was increasing, an undercurrent had been developing of fear of crashes and growing annoyance with the increased noise levels from multi-engined aircraft. This finding was the first substantiated indication that aircraft noise was becoming a serious problem for civil aviation expansion.

Following increased public pressure, Congress amended the Federal Aviation Act of 1958 and directed the FAA to include noise as one of the elements in aircraft certification procedures, and to issue noise abatement regulations. As a result, F.A.R. 36 was promulgated, establishing maximum allowable noise emission levels for all new aircraft, under certain stated flight conditions. As environmental concerns continued to develop, Congress passed the more general Noise Control Act of 1972 which established a National Policy "to promote an environment for all Americans free from noise that jeopardizes their health or welfare". As far as aircraft noise is concerned, the FAA retains primary responsibility for its abatement and control. In recent years, the FAA, EPA and NASA have been considering the utilization of new technology to retrofit JT-3D and JT-8D engines to bring older aircraft such as the 707 and 727 which were exempted from FAR 36 requirements into substantial compliance with these noise regulations.

Throughout public hearings and discussions on retrofit and other more recent FAA considerations of various noise abatement procedures, the basic question arises as to the actual relationships between subjective human annoyance reactions and different levels and qualities of noise exposure. The issue is how much of what kinds of noise is acceptable to how many of what kinds of people. The complex answers to these fundamental questions are needed by administrators to evaluate the expected benefits of various noise abatement proposals.

Residents in a typical community are literally exposed to thousands of different noise events that vary widely in numbers, intensity, duration and tonal qualities over different periods of time, from day to day and month to month. Moreover, these residents are usually engaged in a variety of activities that may or may not be equally responsive to noise interference. Consequently, it is not surprising that field interview studies generally find wide variations in reported annoyance, tension and other health effects among residents exposed to what is believed to be uniform physical noise experiences. These differences are both to single and multiple event noise exposures.

Practically all existing physical indices of complex single event noise exposures are derived from psycho-acoustic laboratory research using comparison judgement and magnitude estimation methodology. The proliferation of the number of indices used by different investigators is a reflection of the inadequacy of these measures to predict annoyance or degree of unwantedness. Only recently has the American National Standards Institute Committee S3-51 on "Auditory Magnitudes" recognized that a sharp distinction must be made between the psycho-physiological perception of sound and the psychological annoyance reactions to sound. The former is an effort to explain how the human hearing mechanism judges abstract loudness or tonal combinations of different durations as noisiness or unpleasantness. Aside from hearing impairment, subjective attitude and experience differences among persons are not considered relevant, since the hearing mechanism itself is considered the important variable. Likewise, such experiments do not usually even consider other important noise environment variables such as the realism and meaningfulness of the complex sound, the authentic simulation of a residential environment in the test chamber, the temporal pattern of the sounds to reflect actual subject experiences, and the inclusion of a real task, such as communication, sleep, rest or work performance, the interference of which transforms sound into unwanted noise. In studying the further processing of perceived sound by the human being into unwanted annoyance and other health effects, the above subject variables ignored by most psycho-acousticians in laboratory studies are extremely relevant and important. In addition, attitudes toward the sound source and those responsible for it, have been found to be substantially related to annoyance responses.

Since 1952, the staff at Columbia University has been engaged in a series of studies of community response to aircraft and other environmental noise sources. The initial research sponsored by the National Advisory Committee on Aeronautics, developed the basic methodology that has been followed in all subsequent field studies by all investigators in this country and abroad. Research on community noise was coordinated by the OECD in the United States 1/2/3/, Great Britain 4/5/, Sweden 6/, Switzerland 7/, France 8/ and West Germany 9/. These field studies have almost uniformly agreed on the primary variables and general conceptual scheme involved in the human annoyance process. First, there is the single noise exposure, which generally varies in at least five important parameters, spectrum, intensity, duration, rise time and relation to ambient noise level. Then, there is the integration of multiple noise exposures, which involves combining varying numbers and types of noises over different time periods.

The second stage in the annoyance process is how a person's hearing mechanism perceives the physical sound stimulus. Here the physiologists and the psycho-acousticians have explained judgements of loudness, pleasantness of tonal combinations and "noisiness" of different sounds. This latter response attempts to assess annoyance but since annoyance is not a simple question of perception and due to the absence of controls over the many human variables influencing annoyance, the responses of equal "noisiness" in most laboratory studies remain ambiguous as to their meaning.

It is the way in which the perceived sound is transformed by higher brain processing into a degree of unwantedness that concerns the study of annoyance. Most traditional sociological variables such as age, sex, education, income and length of residence have generally proven largely unrelated to annoyance in community field studies. Selected attitudes and experiences with a given noise source have generally been found closely related to annoyance judgements. 1-9/ In the case of aircraft noise, all of the above cited field studies have found the following human variables are significantly related to annoyance responses: desired human activities which are interrupted, such as speech, sleep, etc., reported fear of aircraft

crashes where the perceived noise connotes the relative danger of the flight, belief that the noise is harmful to health, feelings of "misfeasance" by the operators of the airplanes, belief in importance of aviation in general and the local airport in particular, and the context of other perceived advantages and disadvantages in living in a particular area. Considering the physical exposure characteristics alone of airplane noise, from 10-25% of the variance in community annoyance responses can be explained. But considering some of the above human variables, as much as 60% of all individual variations in annoyance responses can be accounted. From these field response findings, the impetus was generated to develop a new methodology for including some of these human variables in laboratory studies of annoyance responses. 3/

In 1968 Professor Borsky developed a theoretical concept of field-laboratory research for studying the effects of noise on communities. 10/ From 1969 to date, this new methodology has been developed and proven a valuable tool for studying the complex interaction of varying acoustical stimuli and varying types of exposed subjects. Direct personal interviews have recorded retrospective perceptions, intervening attitudes and experiences and summated annoyance and behavioral real environment responses of samples of residents. These overall annoyance responses combine very complex and varied physical noise exposures over long periods of time. It is extremely difficult, if not impossible, however, from such survey data to reconstruct the process by which residents differentially weight widely varying physical stimuli and integrate their own personal feelings into a single annoyance response. Such detailed data, however, are needed by noise control engineers and administrators and it is our belief that a combination of field and laboratory techniques may be best suited for this task of decoding the possibly varying effects of different aircraft operations on different populations. Moreover, laboratory findings must be related to the responses of residents in the real environment, so that the laboratory findings can be extrapolated back to a community response.

The new research program at Columbia University attempts to utilize the experiences gained in past field and laboratory studies. Small random samples of residents in the vicinity of JFK Airport in New York City, who are exposed to different real life noise environments are interviewed in their homes as part of a regular community study. Details are collected on such personal variables as attitudinal and experience differences as well as reported annoyance and complaint behavior. Sub-samples of those with different predispositions to accept given noise environments are then invited to participate in realistic types of acoustic laboratory studies.

The laboratory, which is an environmental chamber with variable control of the temperature, humidity and noise conditions, is at present furnished as a typical living room in a middle class house. The use of a quadraphonic sound system has succeeded in producing a realistic aircraft noise experience in which a plane appears to fly overhead across the room. Subjects are instructed to participate in a real activity such as watching a color TV program while a variety of controlled noise exposures from aircraft flyovers are simulated in the laboratory and subjects rate each experimental noise in terms of the degree of annoyance and general acceptability. An analysis of the controlled noise levels, the subjective personal factors, and the laboratory responses are utilized to provide more precise measures of average acceptability and any differences for those with hostile or favorable pre-dispositions to the noise.

In a pilot study of this new methodology, 11/ only residents with feelings of medium fear of aircraft crashes living at three distances directly under an approach flight path were asked to come to the laboratory and judge the approach noises from

untreated 727s and two differently acoustically treated 727s. This initial study demonstrated the feasibility of the methodology and also provided some valuable data on the perception and reaction of subjects to a particular retrofit package of the 727 airplane. For the first time, subjects representative of a random sample of residents actually exposed to aircraft noise, were prevailed upon to act as subjects in a controlled laboratory noise experiment. Secondly, the technical ability was demonstrated that aircraft noise tapes could be developed to create the realistic illusion of overhead motion of an airplane in overflight. Subjects voluntarily made comparisons of the laboratory flyovers with their real home environments. Thirdly, data were obtained on what is a perceptible and meaningful dBA difference in annoyance judgements. Annoyance was judged significantly different for two flyovers whose peak noise levels varied by 6 dBA or more, but was not judged differently when the peaks were less than 3 dBA apart.

A second study in 1973-74 tested a complete cross-section of real residential populations, with a full range of pre-dispositional psychological feelings, attitudes and experiences with aircraft noise. It also included a wider range of 18 different realistic noise stimuli, composed of three types of aircraft in both approach and departure operations at three different altitudes related to distance from the airport. Judgements were recorded for each of the separate 18 types of flyovers. 12/ This study, which was the first full scale application of the new methodology provided additional insights into the subjective annoyance process. The subject responses were to three flyovers of the same airplane noise, which had been established as stabilized judgements of essentially single event exposures. The major findings were:

1. That intensity or level of noise was one of the most important physical variables in relation to annoyance responses.
2. That some of the most commonly used noise descriptors such as dBA, PNL, dBD and SPL appeared to be all equally correlated to reported annoyance.
3. That arrivals and departures which have different spectra were equally annoying if the level of noise was approximately the same.
4. That most people realistically do not expect a stressless environment, and that about 80% said they could live with an annoyance level of "2", while only 17% said that an annoyance score of "3" was acceptable, where a 5-point scale of annoyance was used.
5. Subjects with reported feelings of low fear were less annoyed by the same noise exposures than subjects with feelings of high fear. However, the procedures used to invite residents and test them as laboratory subjects appeared to reduce the absolute amount of annoyance differences among the fear groups.
6. A regression equation between reported annoyance and dBA level of noise stimulus indicated that a 10 dBA increase resulted in an increase of approximately one point of annoyance on a 5-point scale. The clustering of annoyance responses at the upper end of the 5-point scale suggested that an annoyance scale with a larger range than 5 points might be better.
7. A comparison of acceptability and annoyance responses for indoor aircraft noise exposures suggested that a peak level exposure of 65 dBA would be acceptable to about 80% of the subjects.

In the fall of 1975, the development of the field-laboratory methodology was extended to test, for the first time, the integrated annoyance and acceptability judgements of a more complex mix of typical aircraft. In fall field interviews, a sample of representative residents were asked to report on their summated annoyance reactions to the actual cumulative aircraft operations of the past summer. In the laboratory, a similar average mix of aircraft, at noise levels estimated to approximate the average actually experienced indoors were judged by sub-samples of residents. A comparison of the two annoyance judgements provides new insights into the dynamic relationships of field and laboratory responses. It furnishes a link, for the first time, between controlled laboratory findings and the complex real environment of noise exposures.

II. Experimental Design

A. Overall Research Objectives

There are five major research objectives included in the experiment described in this report.

1. To develop a conversion function between reported annoyance to TV interference in survey and laboratory responses.
2. To establish the significance between number and level of aircraft noise exposures and annoyance judgements reported in the laboratory.
3. To determine the effects on annoyance responses of fear of aircraft crashes, and other attitudes and personal variables.
4. To determine the relationships between reported annoyance and acceptability judgements. This will help interpret the relative intensity of annoyance responses and to establish annoyance levels that are believed to be acceptable by different types and numbers of residents.
5. To develop a conversion between the new 10-point scale of annoyance used in this study and the 5-point scale previously used in other studies.

B. Acoustic Characteristics of Laboratory Experiment

1. Type and mix of aircraft included

An analysis of actual past records of FAA operations indicated that four types of aircraft at JFK Airport constitute 85-90% of all operations. If the many smaller and quieter aircraft are excluded from the laboratory experiment, then the approximate mix of major aircraft at JFK Airport would be as follows:

707s and DC-8s	50%
747s	20
727s	20
DC-10s and L-1011s	10

2. Type of Aircraft Operations

Very few departures ever take off directly over the areas under the approach path to runway 22L, which are included in this study. Consequently, reflecting this reality, only approach operations are included in the laboratory experiment. This

necessary simplification in the experimental design understates somewhat the fact that 10-15% of all departures at JFK Airport are from the parallel runway (4L), which exposes during periods when due to wind conditions, there are no approaches, the included close and middle distance areas to some additional sideline noise exposures.

3. Activity and Location of Subjects

As will be described in detail in Section E, "Procedures Used", all subjects are seated in a simulated living room and asked to watch a series of half-hour color TV shows while they are exposed to the sounds of a series of flyovers. The time period for watching TV in the home is assumed to be during the evening hours, 7:00 PM - 9:59 PM. Consequently, this time period is used as a frame of reference in replicating the acoustic environment.

4. Noise Levels Tested

Since the three primary sample areas from which subjects were selected are located about 1.9 km (close) 4.0 km (middle) and 8.4 km (distant) from touchdown, the estimated noise levels used in the experiment, adjusted for indoor attenuation of spectra and intensity, 12/ 13/, are as listed in Table 1. Subjects from close residential areas judged noise levels typical for close areas (76-86 dBA); subjects from middle distance judged noise levels of 66-80 dBA, and distant residents judged levels of 58-68 dBA.

TABLE 1

PEAK dBA NOISE LEVELS USED IN EXPERIMENT

<u>Plane Type</u>	<u>S A M P L E A R E A</u>		
	<u>Close (X)</u>	<u>Middle (Y)</u>	<u>Distant (Z)</u>
707 (P1)	86	80	68
747 (P2)	82	79	70
727 (P3)	78	72	60
DC-10 (P4)	76	66	58

5. Rate of Operations

From an analysis of 1973-1974 records of JFK operations, it was estimated that, on the average, when planes are using the approach to runway 22L, about 12 approaches per hour occur during the evening hours, 7:00 PM - 9:59 PM. The "worst day", peak number of flyovers, was estimated at about 24 per hour. The experimental design included these two frequencies of operation plus, one number which was half the average (6 per hour) and one twice the peak (48 per hour). Converted to a half-hour laboratory session period, the four basic experimental acoustic tapes included the following numbers of aircraft:

TABLE 2
NUMBER AND TYPES OF FLYOVERS FOR EACH STIMULUS TAPE

<u>Stimulus</u> <u>Tape</u>	<u>Total</u> <u>Flyovers</u>	<u>P L A N E T Y P E</u>			
		<u>P1</u>	<u>P2</u>	<u>P3</u>	<u>P4</u>
S1	3	2	1	0	0
S2	6	3	1	1	1
S3	12	6	3	2	1
S4	24	12	5	5	2

The actual order and time interval for various airplane flyovers for each tape are shown in Tables 3 and 4.

TABLE 3

ORDER OF AIRCRAFT FLYOVERS FOR STIMULUS TAPE RECORDINGS

A. Close Areas

<u>Flight Number</u>	<u>S T I M U L U S T A P E S</u>			
	<u>Tape 1</u>	<u>Tape 2</u>	<u>Tape 3</u>	<u>Tape 4</u>
1	P2	P2	P2	P2
2	P1	P1	P1	P1
3	P1	P3	P3	P3
4		P1	P1	P1
5		P1	P1	P1
6		P4	P4	P4
7			P2	P2
8			P1	P1
9			P3	P3
10			P1	P1
11			P1	P1
12			P2	P2
13				P2
14				P1
15				P3
16				P1
17				P1
18				P4
19				P2
20				P1
21				P3
22				P1
23				P1
24				P3

B. Middle and Distant Areas

1	P2	P3	P3	P3
2	P1	P1	P1	P1
3	P1	P2	P2	P2
4		P1	P1	P1
5		P1	P1	P1
6		P4	P4	P4
7			P3	P3
8			P1	P1
9			P2	P2
10			P1	P1
11			P1	P1
12			P2	P2
13				P3
14				P1
15				P2
16				P1
17				P1
18				P4
19				P3
20				P1
21				P2
22				P1
23				P1
24				P2

TABLE 4

MINUTE INTERVALS FROM START OF SESSION OF AIRCRAFT FLYOVERS
FOR STIMULUS TAPE RECORDINGS

<u>Flight Number</u>	<u>T A P E N U M B E R</u>			
	<u>T1</u>	<u>T2</u>	<u>T3</u>	<u>T4</u>
1	5:00	3:00	1:00	0:30
2	15:00	8:00	3:30	1:45
3	25:00	13:00	6:00	3:00
4		18:00	8:30	4:15
5		23:00	11:00	5:30
6		28:00	13:30	6:45
7			16:00	8:00
8			18:30	9:15
9			21:00	10:30
10			23:30	11:45
11			26:00	13:00
12			28:30	14:15
13				15:30
14				16:45
15				18:00
16				19:15
17				20:30
18				21:45
19				23:00
20				24:15
21				25:30
22				26:45
23				28:00
24				29:15

6. Order of Tape Presentation

Four balanced orders of presentation were used for the stimulus tapes, as follows:

<u>Order</u>	<u>S E S S I O N S</u>			
	<u>1</u>	<u>2</u>	<u>3</u>	<u>4</u>
A	S1	S2	S4	S3
B	S2	S3	S1	S4
C	S3	S4	S2	S1
D	S4	S1	S3	S2

7. Ambient Noise Level in Living Room

During the flyovers, the TV program determines the ambient noise level and averages about 60 dBA, with peaks of 65 dBA. Without the TV, the room ambient is about 30 dBA.

C. Experimental Environment

1. Acoustic Environment

All tests were conducted in a triple-wall sound-attenuating IAC chamber (Model 400-A), 5.4 m x 4.3 m x 2.4 m furnished as a typical living room in a middle class house. The drawing in Figure 1 shows a schematic of the interior of the room and its furnishings, with the location of a couch comfortably seating three persons, a low cocktail table and two chairs facing a color Setchell-Carlson (Model 5 EC 904) television set, and simulated windows in two of the walls. Four Klipschorn loud-speakers were located in the corners of the room, and a one-way mirror in the wall alongside the television set permitted observation of the subjects from the control room located adjacent to the acoustic chamber. The floor was covered by a rug, and all interior surfaces had pictures and drapes of the types used in the average home, so that the interior appearances and sound conditions were as realistic as possible. Aircraft sounds in the chamber were produced by the four Klipschorn corner-horn speakers to provide an accurate replication of a flyover as heard under actual conditions in an average home. Airplanes were heard flying directly over the room from left to right, at the sound pressure levels which are heard in a typical northeastern United States house with the windows open. Our previous studies have shown that the use of the four-speaker system gives a true sensation of overhead flight in the direction of the phasing of the speakers. They have also shown that listeners inside a room judge a direction of motion of the outside aircraft and, therefore, the sense of directionality must be provided to fulfill the subject's expectations. 10/

2. Sound Reproduction System

The aircraft flyovers were reproduced by the system shown in Figure 2. The recording of the flight was played back by a Crown model 800 tape recorder. The left and right channels were connected to two calibrated variable attenuators (Daven T-730G) which were used to obtain accurate repeatable settings of the reproduced sound pressure level in the chamber. The electrical signals through the attenuators were amplified by two Crown model DC 300 power amplifiers having an output power rating of 150 watts per channel, which powered the four loud-speakers.

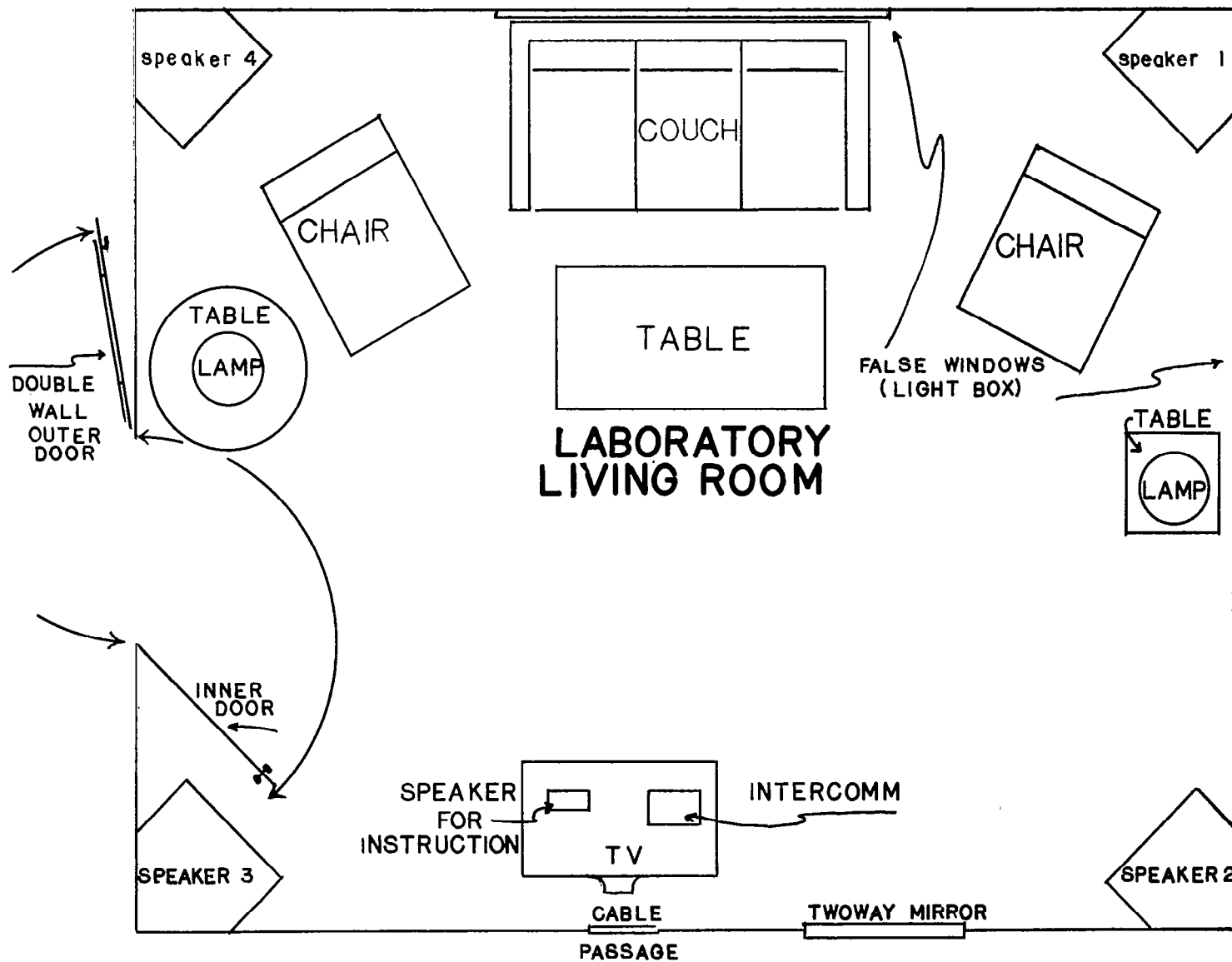
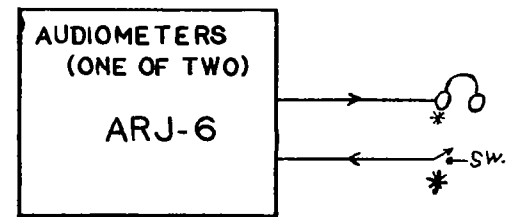
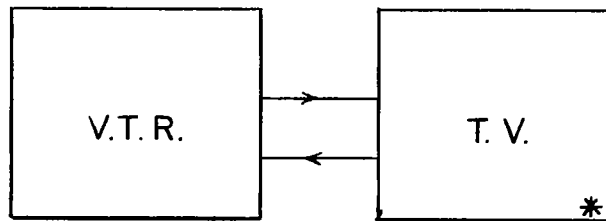
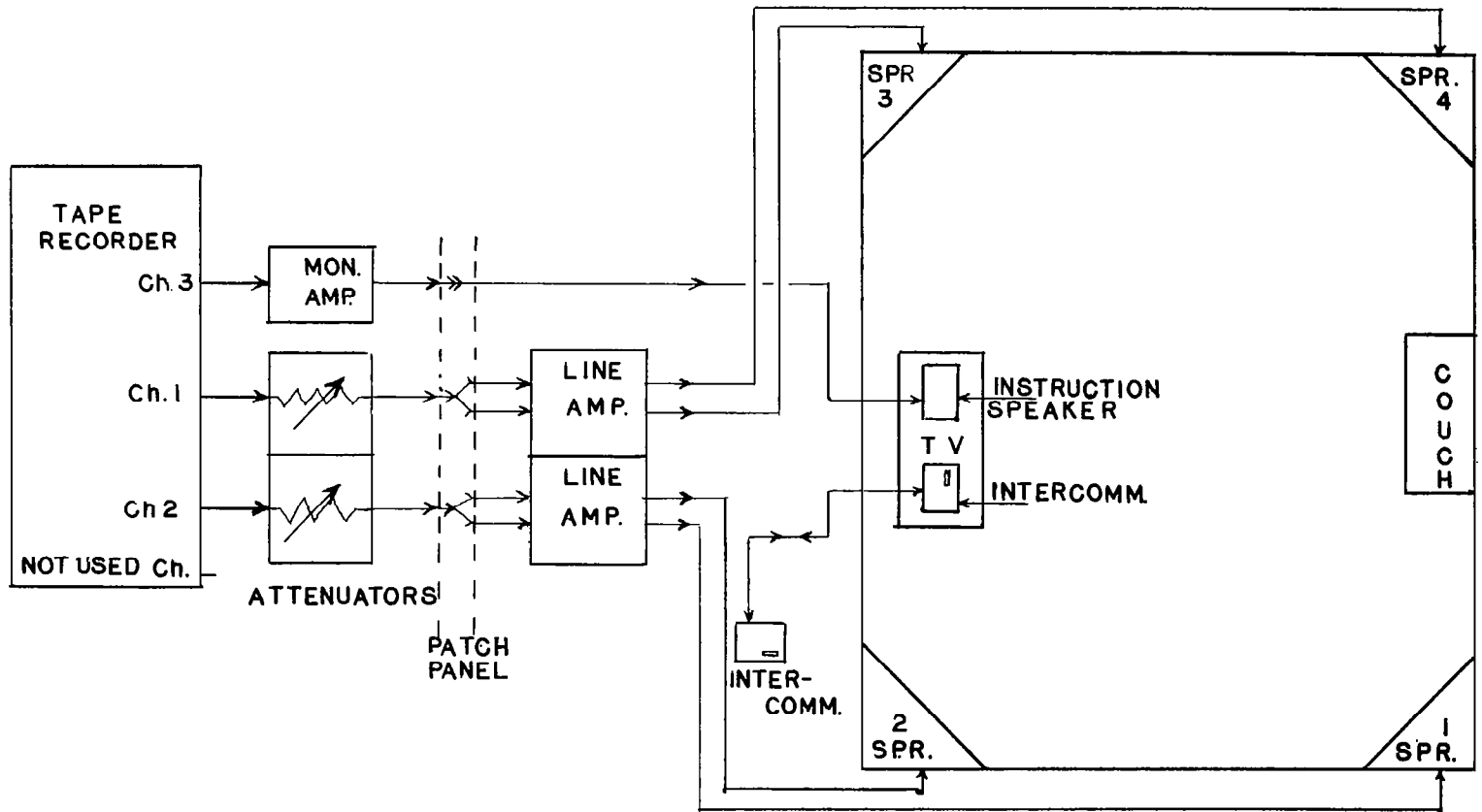

Figure 1.- Laboratory living room.



* LOCATED IN SOUND CHAMBER

Figure 2.- Diagram of sound playback system.

The system is capable of producing a sound pressure level of over 120 dBA in the chamber. The lowest ambient noise level in the chamber is 14 dBA, and therefore, the available dynamic range is 105 dB. When the subjects were in the room, with the heating or airconditioning system in operation, the ambient noise level averaged about 30 dBA. The sound of the television set was adjusted to a mean level of 60 dBA during the tests.

Sound pressure levels of the flyovers in the chamber were calibrated prior to each session with a B & K model 2204 Sound Level Meter.

3. TV Programs Watched

A comparison of national Nielsen ratings indicated the following four half-hour programs were very popular:

1. All in the Family
2. Chico and the Man
3. The Jeffersons
4. On the Rocks

The programs were shown in the order indicated above.

D. Subjects to be Tested

A total of 216 subjects were selected from a representative stratified random sample of 1300 residents as follows:

<u>Fear Group</u>	<u>Total</u>	<u>Distance of Residence from Runway</u>		
		<u>Close (X)</u>	<u>Middle(Y)</u>	<u>Distant(Z)</u>
High	72	24	24	24
Medium	72	24	24	24
Low	<u>72</u>	<u>24</u>	<u>24</u>	<u>24</u>
Totals	216	72	72	72

E. Procedures used in Experiment

1. Field Interviews

The sampling procedure is designed so as to maximize the homogeneity of noise exposure within each surveyed area. Since noise levels from aircraft drop rapidly as one moves laterally away from landing and take-off flight paths, and as one moves farther from the end of a runway, it was necessary to intensively sample areas only a few blocks in diameter.

All interviewers were given predesignated addresses in the sample areas, each consisting of small clusters of adjacent blocks. In some assignment locations where the number of dwellings are limited, every household was contacted. In other areas, every n^{th} dwelling was selected. Respondents are required to be over 18 years old, a permanent resident of that dwelling and not in employment at that residence. Three primary sample areas were selected to represent three levels of noise exposure. The close (X) areas were about 1.9 km from touchdown (Part 36 measuring point) and included parts of the community known as Rosedale. The middle distance (Y) areas were about 4.0 km away and included parts of Laurelton,

while the distant areas (Z) located about 8.4 km from touchdown, consisted of residents living in Floral Park. Figure 3 presents the location of the sample areas and the Columbia University facility.

2. Stratification of Residents by Reported Feelings of Fear of Crashes

While it would be desirable to stratify residents by a general index of psychological predisposition toward aircraft, as a practical matter, only the fear response is used as an abbreviated index. Fear is highly intercorrelated with feelings of misfeasance, health effects and other predisposition factors and consequently, may be used as an indicator of the general predisposition scale.

The fear scale used in the present study consisted of a summation of four items from the community questionnaire. Fear is defined as a belief that aircraft flying overhead poses a threat to one's safety. The noise connotes an approaching plane and fear is the belief that it may crash into the place where the person is located. The Likert summated ratings technique ^{14/}, is used to measure the intensity of a human response. In this process, the separate scores for response categories of a set of questions, all representing a particular dimension or attribute, are summed to form a composite rating. By using a set of questions rather than a single question, greater reliability in the measurement of the dimension or attribute is usually obtained. The four questions are:

Question 5B, Item 6. Respondents were asked how much they disliked twelve aspects that apply to living conditions in their community. Each respondent referred to an "opinion thermometer" on which "0" corresponded to "none" and "9" corresponded to "Extremely". In Question 5B, Item 6, respondents rated the dislike of

Dangerous Air Traffic Conditions

Question 9D. How much does the noise from (item) startle or frighten you? The question was asked for various (5) noise sources. The response to airplane noise was used in the fear scale. Again the response choices ranged from "0" (not at all) to "9" (Extremely).

Question 26. When you see or hear airplanes fly by, how often do you feel they are flying too low for the safety of the residents around here? Response choices were "0" (not at all) to "9" (Extremely often).

Question 27. "And how often do you feel there is some danger that they might crash nearby?" Response choices were "0" (not at all) to "9" (Extremely often).

Each respondent's fear score was obtained by summing the responses to each of the four fear items. Since possible responses for each item were 0-9, the range of fear scores was 0-36. Since the fear scale scores provide a theoretical continuum of reported intensity of subject feelings of fear of crashes, the separation of all respondents into a number of classes such as low, medium and high fear groups is somewhat arbitrary. Two considerations were used in deciding the score ranges used in this study for the three classes of fear. First, it was deemed desirable to maintain comparability, as much as possible, to previous Columbia University and other field studies. Second, there was the practical necessity to provide a sufficient pool of residents within each fear and distance classification so that a sufficient number of subjects would be obtained for the experiment. With regard to the first criterion, the low fear group has been defined in the past as having little or no fear, with a score of 0-1 in a 5-point scale with a score range of 0-16; high fear was defined as

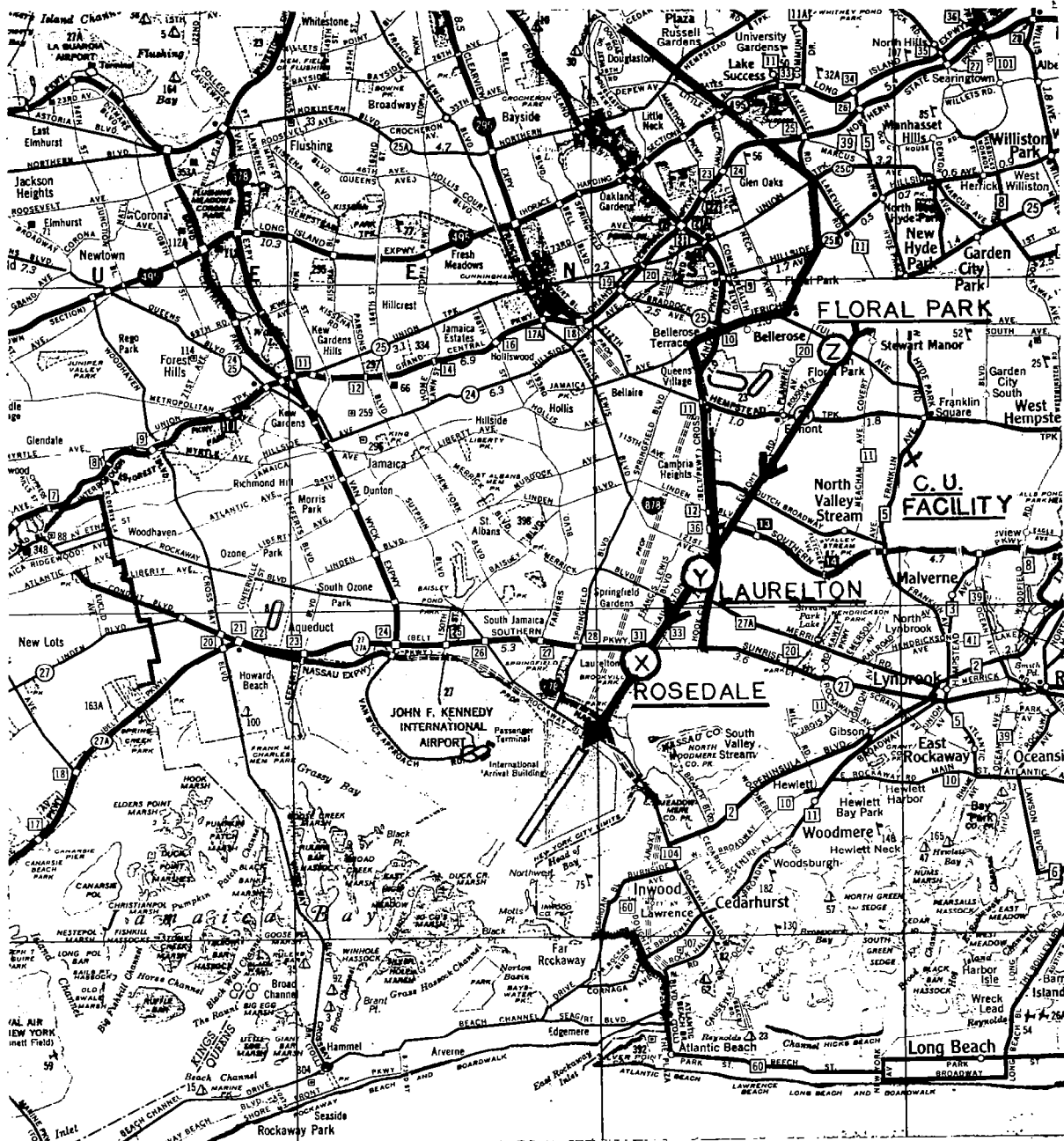

Figure 3.- Location of Columbia University Research Facility and approach path to runway "22L."

having a score of 8 or more, or at the middle range or greater; medium fear included all other responses with scores of 2-7. Since this study is using a 10-point response scale for each question in an effort to secure less clustering of responses, a 0-1 classification for low fear would be the approximate equivalent of 0-3 on the new scale. However, a serious crash at Rosedale, the close area, in late June 1975, appears to have generally raised the fear level of all residents along the approach flight path used in this study. In order to maintain about the same proportions of low fear responses and obtain a sufficient number of subjects, it was necessary to slightly increase the scale score range of the low fear group to 0-5. The high fear classification was kept comparable to past studies, with a score interval of 18 or more. It should be noted that these classifications of fear are used to test for possible differences in annoyance responses among subjects in the analysis of variance, and the small change in the classification of low fear in this study is conservative in that it might possibly reduce the relative differences in annoyance responses. In the correlation analyses, the actual fear scale score for each subject is used, so the classification issue is not relevant.

To summarize the fear classification scheme, all respondents were placed in the following three basic groups in accordance with their fear scale scores:

<u>Fear Group</u>	<u>Scale Scores</u>
Low	0-5
Medium	6-17
High	18-36

3. Invitation to Subjects

Each fear group from the distant (Z) area was invited into the laboratory first and exposed to the acoustic tapes for distant area (Z) noise levels. The separate fear groups from middle distance (Y) and close distance (X) areas were subsequently tested in separate series of sessions. The scenario for the invitation to the laboratory which helps determine subject expectations was as follows:

"Hello: I am _____, a supervisor from Columbia University Research Center. Are you (the person who was interviewed earlier)? I want to thank you for helping us in our study of community problems by answering all of our questions on the interview. As you know, we are part of a research group interested in studying questions concerning the quality of our air, water, noise and other related matters. In order to do this, we need to talk to representative samples of residents, with all points of view, living in different communities.

"As you probably know, some people are concerned about aircraft noise in the metropolitan area. (In some areas it is more important than in others.) Consequently, in this particular study we are interested in determining how people feel about aircraft noise. The findings will provide useful information to city planners and interested community groups. While almost everyone wants a quiet neighborhood, we know it is going to be difficult to reduce noise. What we want to find out is how much aircraft noise should be reduced in order to be acceptable to the public. Columbia University has constructed a special research center, nearby in Franklin Square, to which we are inviting citizens like yourself, to help in this vital, and we hope, interesting research.

"When you come to Franklin Square, you will relax in a living room, watching popular TV shows while different aircraft fly over. If you are used to doing (needle-point or) something (else) while watching TV, you are invited to do so. You will simply be asked about your reactions to the various aircraft. This visit will take a little more than two hours. We will provide door-to-door transportation and refreshments. In appreciation and as a token of thanks for your cooperation, you will receive \$8. We have a number of alternative times and dates for coming to our center and would appreciate knowing when it would be best for you. First, could you come

Three subjects of the same fear and distance classification were scheduled for each session. In the event that some of the subjects were unable to keep an appointment, repeat sessions of the same stimulus sequence were scheduled. If only one subject appeared, a staff member, who was unknown to the subject, sat in as a substitute, so that at least two people were in the test chamber at all times.

The subjects were taken from their homes and driven to the research facility by a Columbia University staff member. Once taken into the simulated living room, they were given the following instructions:

"Please go into the living room and be seated on the couch. As you know, Columbia University has an extensive environmental research program, of which our group is a part. We are interested in learning more about how people respond to different noises, especially those from airplane flyovers.

"We are going to have several TV shows for you to watch, each lasting about a half hour. From time to time you will hear airplanes flying over. At the end of each half-hour program, you will hear a voice from this speaker (point to front over TV), asking you to record your responses to the airplanes which you have just heard during the program.

"Here is your reaction sheet. Please fill in your name and address. In the first line labelled annoyance, I would like you to indicate the extent to which the aircraft flyovers annoyed or bothered your watching and listening to the TV program.

"There is no right or wrong answer. If you are not annoyed, we don't want you to say you are. We just want to know how you feel. You will notice on the right hand side of the sheet, a thermometer which we used in the interview, with numbers 0-9. 0 means that the airplanes did not bother or annoy you at all. 9 means that you were extremely annoyed. Any number in-between would indicate that your feelings were something greater than 0 but less than the top category of 9.

"After recording your annoyance response, I want you also to place a check in the "YES" or "NO" box in the second line labelled "acceptability" (point) to indicate whether or not you believe the airplane flyovers you have just rated would be acceptable to you; by this I mean whether or not you feel that you could learn to live with them if you heard them regularly in your own home while watching TV.

"You will note that there are four columns, one for each half-hour program. You will not be required to answer after each aircraft flyover, but only at the end of each program when you hear a voice from this speaker, (point to speaker).

"Please also notice that there are three more lines for comparing airplane flyovers over your home with those you just heard here. We realize that some days you may have more flyovers than other days. What we want you to do is to make a general comparison as best you can of your feelings when the planes are flying by. First, we want your best judgement whether the number of airplanes you just heard was more, about the same or less than you usually hear at home during a typical half-hour in the evening from 7:00 PM to 11:00 PM, when the airplanes are flying over and you may be watching TV. Second, we want you to compare the amount of noise from the airplanes you just heard, and last, we want you to judge the amount of your annoyance with the planes you just heard compared to your annoyance at home when you are watching TV in the evening. Enter one check for each of these three comparisons.

"After each time you hear the voice asking you for your response, you will enter your answers on each line, one number to indicate how you feel about the amount of annoyance, one check to express your acceptability with the aircraft flyovers and one check for each of the three questions comparing the flyovers you just heard with your usual home experiences.

"At the end of each session, we will have a brief coffee-break. If at any time during the session you want to talk to one of us for example: if the TV picture or sound is not clear, you can do so by pressing the button on top of the TV speaker and then releasing it and then you will be able to talk.

"Please try to record your own personal feelings about the airplanes flying here. Try not to influence each other by avoiding any discussion or indication of how you, yourself, feel about them. From our past experience, we know that there may be a strong temptation to compare your ratings with others in the room. As you know, no two people are alike in their feelings about noise and if you discuss your ratings, it will make our findings less valid; so please, wait until the very end of the fourth session to discuss your ratings if you feel you must, but not during the sessions when you are making your own judgements. Of course, if you want to talk about the TV program, as you might at home, feel free to do so. We want you to relax and act as much as possible as if you were in your own home."

At this point the TV monitor was activated and the interior and exterior chamber doors were closed by the departing staff member. After each half-hour session, the staff member reentered the living room, checked the reaction sheets

for completeness of responses and the subjects had a brief coffee-break, used the rest rooms or just relaxed between sessions. After the fourth session, the subjects were thanked, informally debriefed, paid an \$8 honorarium and driven home. A copy of the reaction sheet is shown in Figure 4.

It might be of interest to note that in the fourth paragraph of the above instructions, subjects are only cautioned that "if you are not annoyed, we don't want you to say you are". The opposite caution was not used, "if you are annoyed, we want you to say you are", because previous studies had indicated that coming to the laboratory sometimes appears to create an upward bias in response 12/, and the instruction was designed to mitigate this bias. Some of those who are more favorably predisposed to aircraft noise in their home environment sometimes feel that the fact that the University considers aircraft noise sufficiently important to conduct further study may mean the problem is more important than they had believed. Consequently, they appear to reassess their annoyance responses in the laboratory. Of course, the instructions do positively emphasize a neutral position of the study, "we just want to know how you feel".

III. Findings

A. Representativeness of Sample

1. Completion Rate of Field Interviews

As Table 5 indicates, about 82% of all randomly assigned households were successfully interviewed, while less than one out of ten contacts refused the interview. This compares favorably with interviewing experience in the New York metropolitan area and indicates the representativeness of the interviewed sample.

2. Representativeness of Subjects Participating in Laboratory Study

Table 6 presents a picture of the outcomes of invitations to participate in the laboratory study. About half of all sample respondents agreed to make an appointment, while almost 10% refused. The remainder were unable to make an appointment within the time schedule of the experiment. About 70-80% of those who made an initial appointment, or over a third of all residents who were ever invited to participate, eventually became subjects.

Table 7, which presents selected personal and attitudinal data for laboratory subjects and non-participants, indicates that there are no significant or substantial differences for middle (Y) or distant (Z) residents. With respect to close low fear Rosedale residents, however, there is somewhat more fear, higher income and more TV annoyance expressed by subjects than non-participants ($p < .05$). This suggests that all subjects except the 24 low fear subjects from the close area are an unbiased representative sub-sample of residents. The relatively few available close residents (50) with feelings of low fear limited our ability to correct this deficiency. The low fear subjects from the close area may reflect a small upward bias in annoyance responses in the laboratory for this group.

B. Description of Aircraft Noise Exposures

1. Actual Aircraft Operations

As Table 8 indicates, actual operations on runway 22L varied considerably from month to month over the period July-October 1975. While the resident who was interviewed in September and October was asked to respond to his perception and annoyance with the airplanes during the past summer, operations during the months in which the interviews occurred are also shown, since they may have unconsciously influenced these judgements. As can be seen, the proportions of 707s and 747s actually landing over the sample areas were somewhat less than the numbers estimated for the laboratory tapes. The differences in averages for July and

NAME: _____
 ADDRESS: _____ (Street)
 _____ (Town)

		SESSIONS			
		1	2	3	4
A. Annoyance		Score 0-9			
		_____	_____	_____	_____
B. Acceptability	Yes	_____	_____	_____	_____
	No	_____	_____	_____	_____
C. Comparisons with Home Airplane Flyovers					
1. Was the <u>number</u> of airplanes you just heard <u>more</u> , about the <u>same</u> or <u>less</u> than you <u>usually</u> hear at home during a half-hour in the evening from 7:00 PM to 11:00 PM?	More	_____	_____	_____	_____
	Same	_____	_____	_____	_____
	Less	_____	_____	_____	_____
2. Was the amount of <u>noise</u> from the airplanes you just heard <u>louder</u> , about the <u>same</u> or <u>quieter</u> than you <u>usually</u> hear at home during a half hour in the evening from 7:00 PM to 11:00 PM?	Louder	_____	_____	_____	_____
	Same	_____	_____	_____	_____
	Quieter	_____	_____	_____	_____
3. Was your <u>annoyance</u> from the airplanes you just heard <u>more</u> , about the <u>same</u> or <u>less</u> than you usually feel when you watch TV at home during the evening from 7:00 PM to 11:00 PM?	More	_____	_____	_____	_____
	Same	_____	_____	_____	_____
	Less	_____	_____	_____	_____

FOR OFFICE USE
 Date
 Condition
 No.
 Distance

CU - 9/75

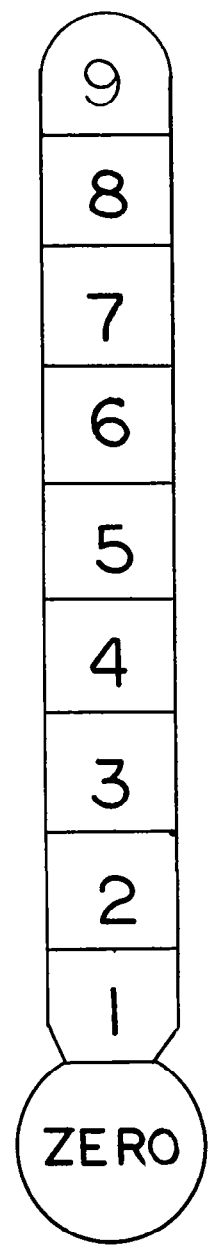

"HOW MUCH"
 EXTREMELY

NOT AT ALL
 OR
 NONE

20

Figure 4.- Reaction sheet.

TABLE 5

COMPLETION RATES OF ASSIGNMENTS

	<u>Distant (Z)</u>		<u>S A M P L E A R E A</u>				<u>TOTAL</u>	
	<u>No.</u>	<u>%</u>	<u>Middle (Y)</u>		<u>Close (X)</u>		<u>No.</u>	<u>%</u>
			<u>No.</u>	<u>%</u>	<u>No.</u>	<u>%</u>		
Total Assigned Residences	813		509		702		2024	
Not contacted	187		100		155		442	
Contacted Residences	626	100 %	409	100%	547	100%	1582	100%
Completed Interviews	500	79.9	338	82.6	456	83.4	1294	81.8
Not Completed	126	<u>20.1</u>	71	<u>17.4</u>	91	<u>16.6</u>	288	<u>18.2</u>
Refusal	48	7.7	37	9.1	49	8.9	134	8.5
Other	78	12.4	34	8.3	42	7.7	154	9.7

TABLE 6

OUTCOME OF INVITATIONS TO PARTICIPATE IN LABORATORY STUDY

A. Low Fear Group	D I S T A N C E O F R E S I D E N C E							
	C L O S E		M I D D L E		D I S T A N T		T O T A L	
	No.	%	No.	%	No.	%	No.	%
Total Contacted	50	100	57	100	64	100	171	100
Refusal	11	22	8	14	13	21	32	19
Temporarily unavailable	9	18	14	25	22	34	45	26
Appointment	<u>30</u>	<u>60</u>	<u>35</u>	<u>61</u>	<u>29</u>	<u>45</u>	<u>94</u>	<u>55</u>
Kept 1st	21	42	17	30	21	33	59	35
Kept 2nd	1	2	5	9	3	5	9	5
Kept 3rd	2	4	2	3	0	0	4	2
Subject cancel	6	12	9	16	4	6	19	11
C.U. cancel	0	0	2	3	1	1	3	2
B. Medium Fear Group								
Total Contacted	81	100	56	100	67	100	204	100
Refusal	11	14	5	9	4	6	20	10
Temporarily unavailable	36	44	22	39	35	52	93	45
Appointment	<u>34</u>	<u>42</u>	<u>29</u>	<u>52</u>	<u>28</u>	<u>42</u>	<u>91</u>	<u>45</u>
Kept 1st	22	27	21	38	23	34	66	32
Kept 2nd	3	4	3	5	1	2	7	4
Kept 3rd	0	0	0	0	0	0	0	0
Subject cancel	7	9	5	9	2	3	14	7
C.U. cancel	2	2	0	0	2	3	4	2
C. High Fear Group								
Total Contacted	82	100	82	100	55	100	219	100
Refusal	3	4	5	6	2	4	10	5
Temporarily unavailable	45	55	43	52	24	43	112	51
Appointment	<u>34</u>	<u>41</u>	<u>34</u>	<u>42</u>	<u>29</u>	<u>A/</u>	<u>97</u>	<u>44</u>
Kept 1st	17	21	24	30	20		61	28
Kept 2nd	8	10	1	1	4		13	6
Kept 3rd	0	0	0	0	0		0	0
Subject cancel	6	7	8	10	5		19	8
C.U. cancel	3	3	1	1	0		4	2

A/ Excludes 6 subjects used in pre-test

TABLE 7

COMPARATIVE CHARACTERISTICS OF SUBJECTS AND NON-PARTICIPANTS

<u>Characteristics</u>	<u>S U B J E C T S</u>			<u>N O N P A R T I C I P A N T S</u> ^{1/}		
	<u>Distance of Residents</u>			<u>Distance of Residents</u>		
	<u>Close</u> N=24	<u>Middle</u> N=24	<u>Distant</u> N=24	<u>Close</u> N=266	<u>Middle</u> N=149	<u>Distant</u> N=228
<u>A. High Fear</u>						
<u>Sex</u>						
Male	21%	29%	13%	28%	34%	20%
Female	79	71	87	72	66	80
Median Income	\$ 11,852	\$ 16,673	\$ 18,340	\$ 13,750	\$ 18,149	\$ 19,375
Mean Fear	28.0	28.0	30.3	27.7	26.8	27.1
Mean TV Annoyance	8.6	8.1	8.5	8.3	7.6	8.3
Mean general aircraft annoyance	68.7	58.1	65.5	63.0	54.6	62.4
<u>B. Medium Fear</u>	N=24	N=24	N=24	N=84	N=70	N=120
<u>Sex</u>						
Male	33%	21%	42%	45%	26%	25%
Female	67	79	58	55	74	75
Median Income	\$ 15,359	\$ 17,859	\$ 17,520	\$ 13,366	\$ 17,850	\$ 17,279
Mean Fear	12.1	11.9	11.6	12.4	11.4	11.1
Mean TV Annoyance	6.0	6.0	6.2	6.5	5.5	5.8
Mean general aircraft annoyance	32.5	30.2	35.8	33.7	24.9	31.4
<u>C. Low Fear</u>	N=24	N=24	N=24	N=32	N=45	N=67
<u>Sex</u>						
Male	38%	50%	17%	34%	56%	39%
Female	62	50	83	66	44	61
Median Income	\$ 14,990	\$ 16,995	\$ 17,507	\$ 11,103	\$ 15,990	\$17,500
Mean Fear	2.5	1.5	0.9	1.5	1.7	2.0
Mean TV Annoyance	5.9	3.0	4.5	4.1	4.1	4.8
Mean general aircraft annoyance	21.6	11.5	18.0	20.4	16.7	20.2

^{1/} 17 completed interviews are excluded as follows: 13 distant residents - 6 used in pretest, 6 did not hear aircraft and were not asked about field TV annoyance and one had poor comprehension of instructions. The other 4 residents came to the laboratory, but were classified as ineligible subjects - 2 with poor comprehension and 2 were extra subjects who were scheduled at the close of the study in case other subjects cancelled their appointments.

TABLE 8

PERCENT DISTRIBUTION OF MONTHLY ARRIVALS ON RUNWAY 22L
DURING THE EVENING HOURS 7:00 PM - 9:59 PM BY TYPE OF AIRCRAFT

<u>1975 Month</u>	<u>707/DC-8</u>	<u>747</u>	<u>727</u>	<u>DC-10/L1011</u>	<u>Total</u>	
					<u>No.</u>	<u>%</u>
July	39.3%	17.9%	29.0%	13.8%	1155	100%
August	42.5	16.7	26.5	14.3	904	100
September	48.3	18.0	20.8	12.9	596	100
October	48.9	17.5	22.5	11.1	440	100
Average July-August	40.7	17.4	27.9	14.0	2059	100
Average September-October	48.6	17.8	21.5	12.1	1036	100
Average July-October	43.3	17.5	25.8	13.4	3095	100
Laboratory Average	50	20	20	10	-	100

TABLE 9

FREQUENCY DISTRIBUTION OF THE NUMBER OF DAILY ARRIVALS
ON RUNWAY 22L DURING THE EVENING HOURS

<u>Number of Planes</u> <u>Per Hour</u>	<u>N U M B E R O F D A Y S P E R M O N T H</u>			
	<u>July</u>	<u>August</u>	<u>September</u>	<u>October</u>
0	5	14	13	20
< 2	4	0	4	2
2-2.9	0	0	0	0
3-5.9	0	2	1	0
6-9.9	3	1	2	0
10-14.9	5	4	1	1
15-19.9	2	7	3	3
20+	<u>12</u>	<u>3</u>	<u>6</u>	<u>5</u>
TOTAL	31	31	30	31
Average excl. "0"	17	20	14	16
Peak number	31	34	25	21

August were greater than for September and October. In any event, the limitations on the number of planes that could be included in the laboratory tapes made it impossible to present more precise proportions of the actual aircraft mix.

Table 9 presents the variations in daily flight operations over the sample areas. Due to wind and other operating factors, about half of all days during August and September and two-thirds of the days during October, had no landings over the sample areas. In July, however, only 5 of the 31 days (16%) were without planes overhead. On days when the planes did use runway 22L, the variations in daily numbers ranged from an average of 14 per hour during September to 20 per hour during August. In the model used in this experiment, S2 (6 per half hour) was assumed to represent the average hourly experience. Obviously, this assumed number of 12 per hour was somewhat too low, since the actual four-month average was 17 operations per hour. Likewise, while S3, which was supposed to represent the peak number of exposures included 12 flights per half hour or an hourly rate of 24 operations, the actual peak daily experience averaged 30 per hour or 15 per half hour.

Comparing the experimental stimulus tapes with the "knowledge after the fact" actual operations, it can be concluded that:

- S1 was about one-third of the actual average
- S2 was about 70% of the actual average
- S3 was about 40% above the actual average and 80% of the actual peak
- S4 was about 60% more than the actual average peak

Thus, S2 was in fact closest to the actual average and S3 was closest to the peak or "worst" day exposure.

2. Spectral Characteristics and Time Histories of Stimulus Tapes

Figures 5-8 present the spectral characteristics of the peak dBA noise level for each of the four plane types and three distance sample areas. Figures 9-12 present the time histories for the planes landing over the close areas; figures 13-16 the time histories for the middle distance areas and figures 17-20 those for the distant areas.

Peak dBA levels for all planes and distances were presented in Table 1 and were measured at the ear level of the center of the couch without subjects present in the room.

C. Reported Annoyance with TV Interference in the Field Interview and Laboratory Sessions

Table 10 presents the comparative mean annoyance responses for the 216 subjects in their interview and laboratory sessions. It is important to note a number of general observations. First, annoyance in both field and laboratory reports appears to increase as fear of crashes increases. Second, annoyance generally increases as the number of exposures increases, and third, it increases as the level of noise increases as the distance of the area from the airport decreases. These observations will be statistically supported in the discussions that follow and are consistent with previous research findings.

It should also be noted that "t" tests of the differences between reported field and laboratory mean annoyance responses indicate that for all subjects and for the close area subjects, the mean for stimulus 3 (approximate peak number of actual exposures) appears to be closest to the integrated field annoyance response. The "t" test indicates that there are no significant differences between these means. This observation is further supported by correlation analyses discussed in subsequent sections.

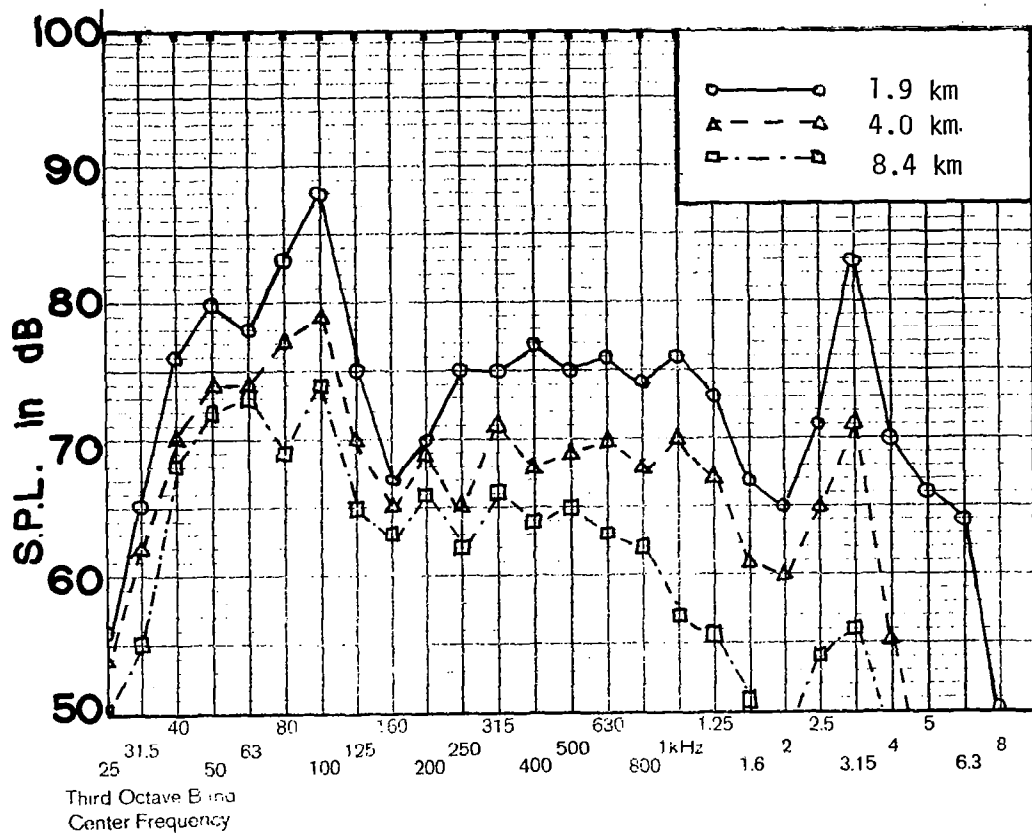

Figure 5.- Indoor noise spectra of 707 maximum dBA level on approach.

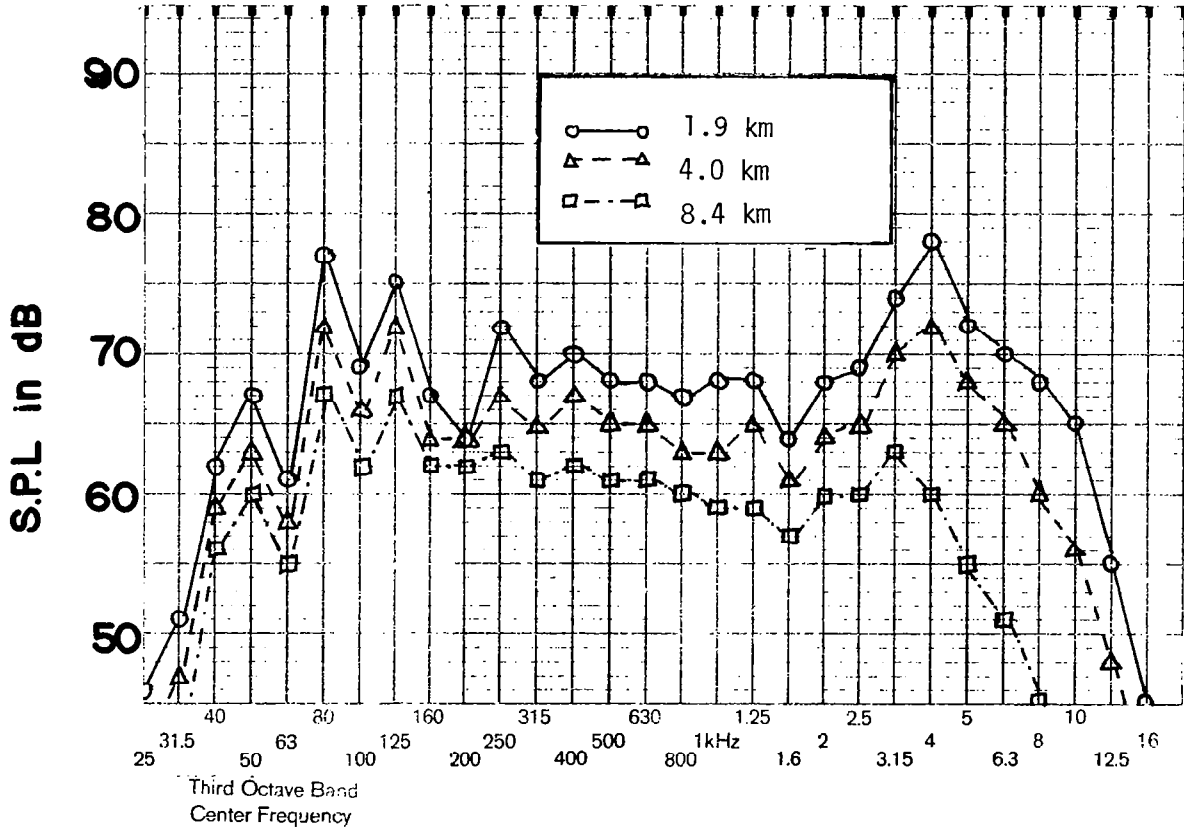

Figure 6.- Indoor noise spectra of 747 maximum dBA level on approach.

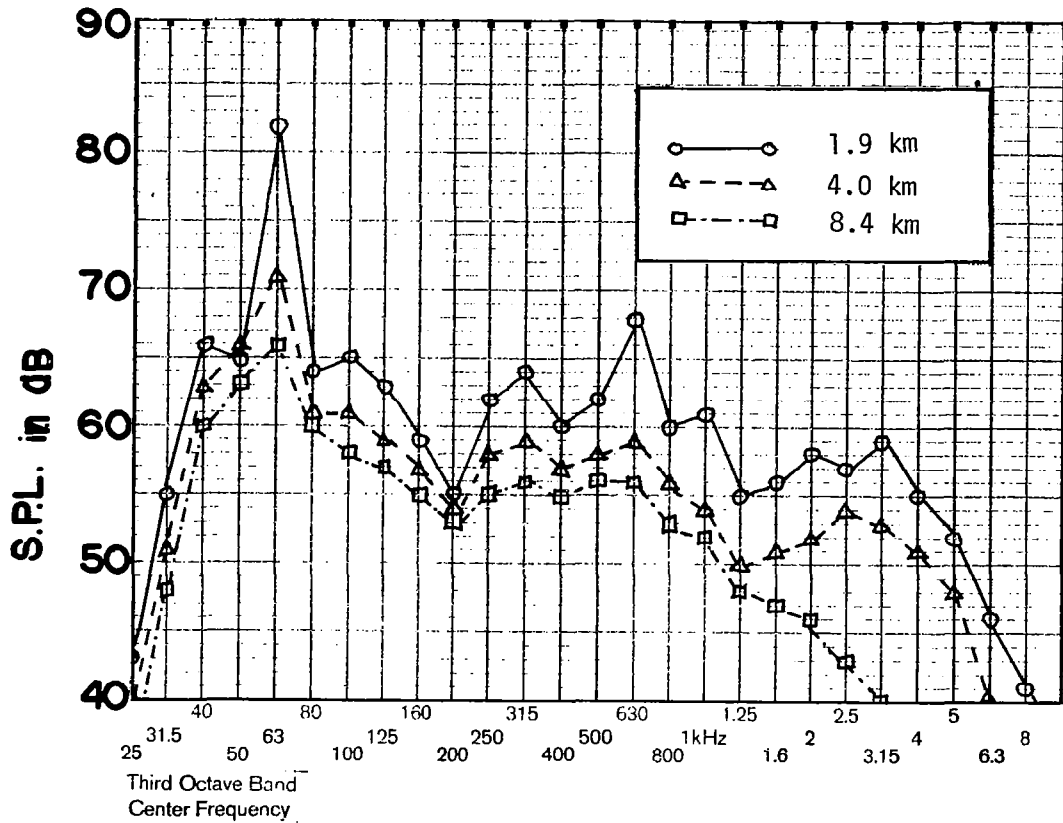

Figure 7.- Indoor noise spectra of 727 maximum dBA level on approach.

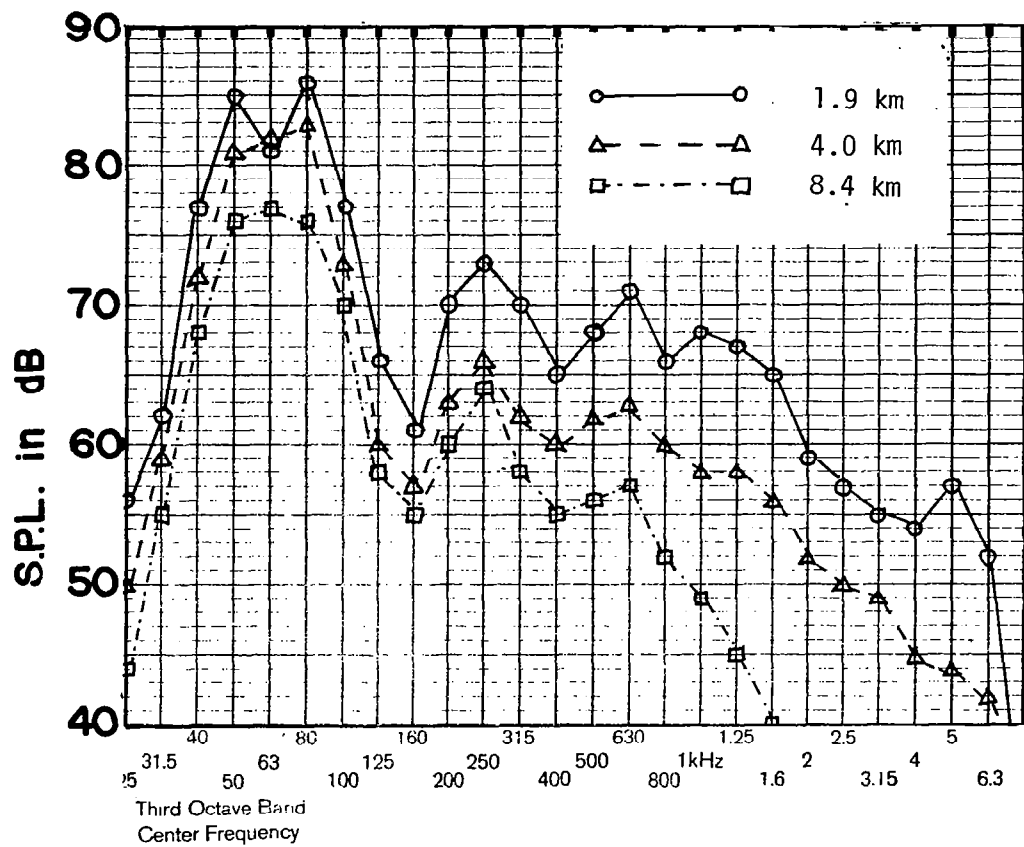

Figure 8.- Indoor noise spectra of DC-10 maximum dBA level on approach.

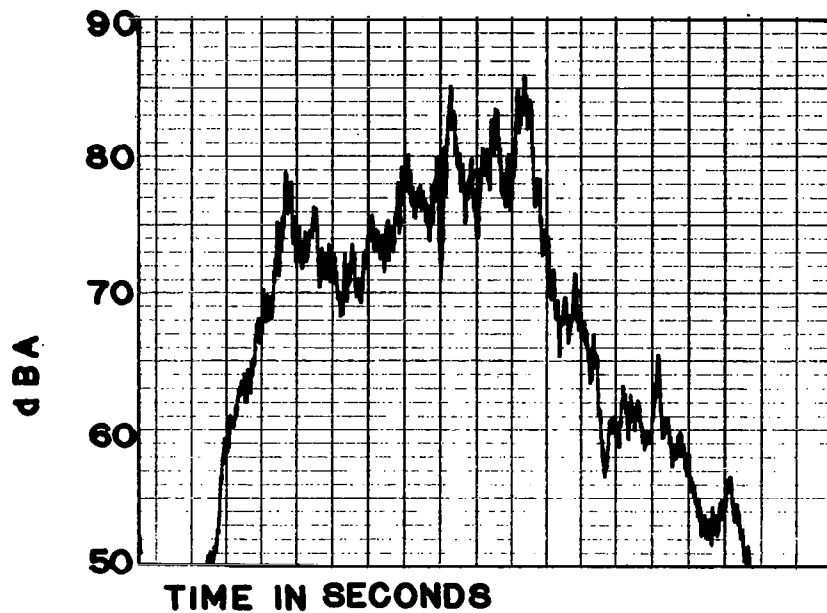

Figure 9.- Indoor dBA levels of 707 1.9 km from touchdown - time history.

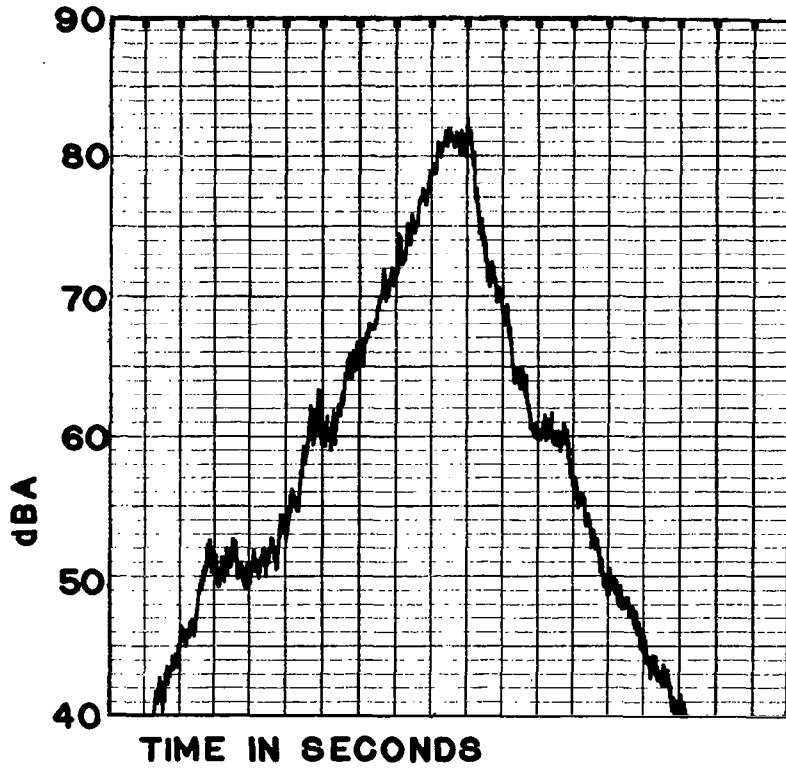

Figure 10.- Indoor dBA levels of 747 1.9 km from touchdown - time history.

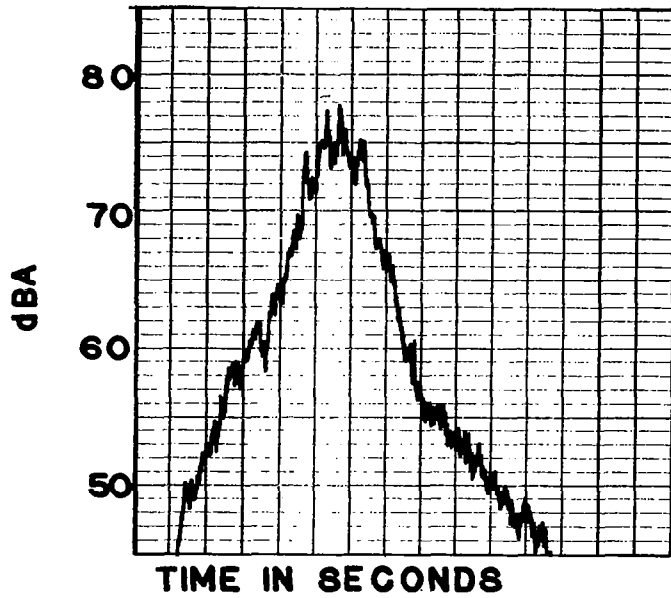

Figure 11.- Indoor dBA levels of 727 1.9 km from touchdown - time history.

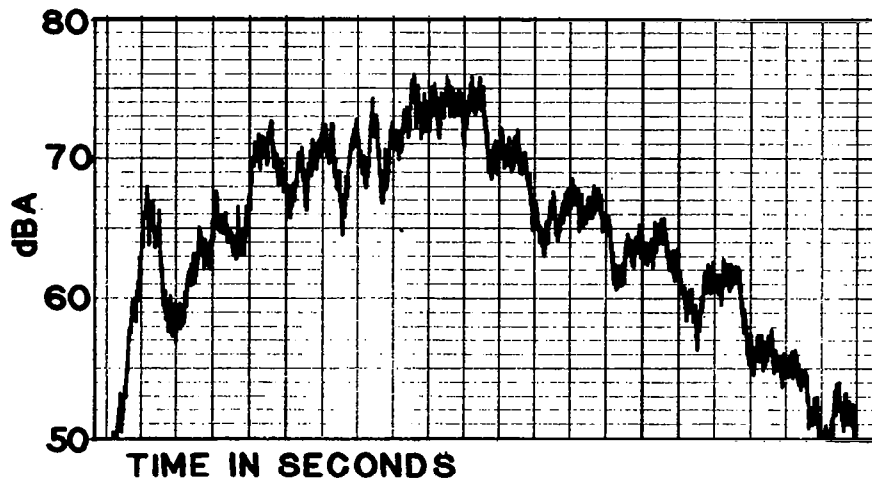

Figure 12.- Indoor dBA levels of DC-10 1.9 km from touchdown - time history.

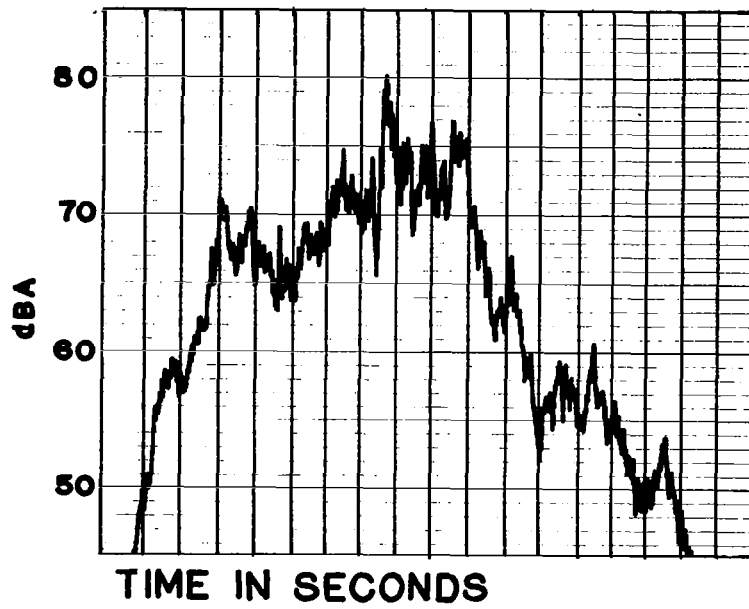

Figure 13.- Indoor dBA levels of 707 4.0 km from touchdown - time history.

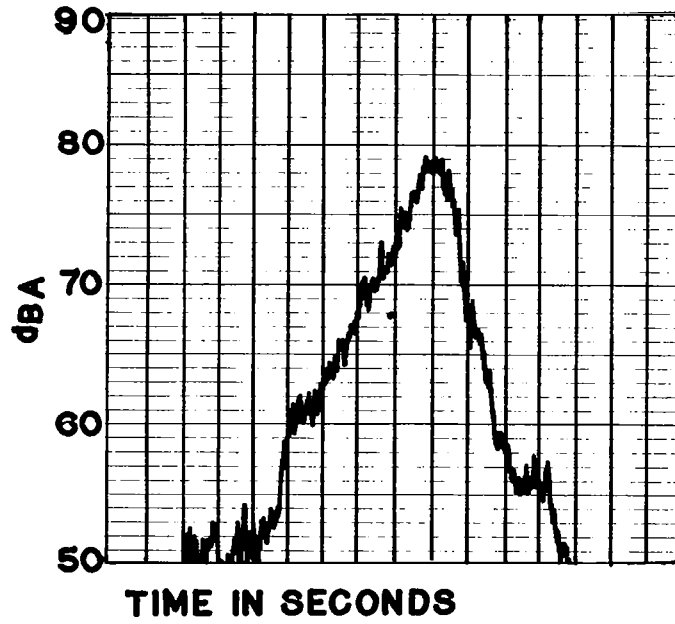

Figure 14.- Indoor dBA levels of 747 4.0 km from touchdown - time history.

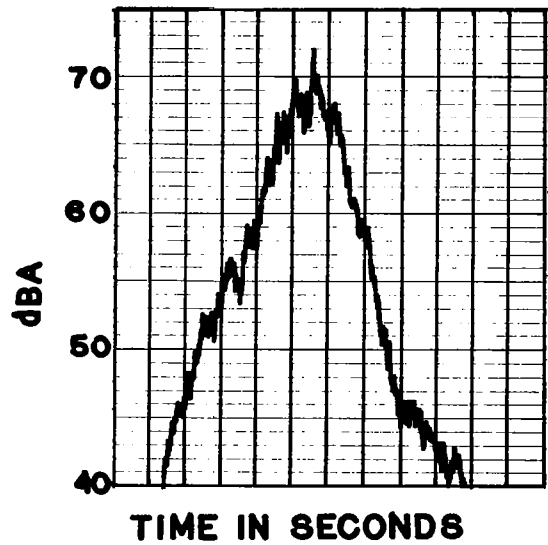

Figure 15.- Indoor dBA levels of 727 4.0 km from touchdown - time history.

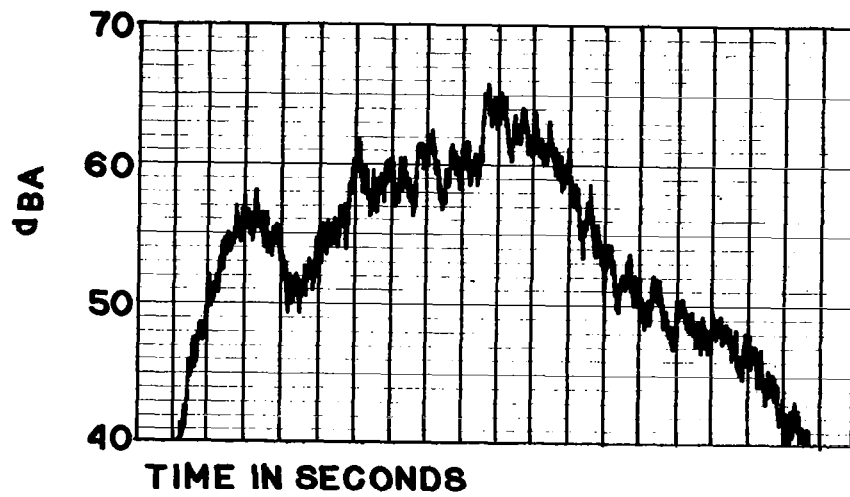

Figure 16.- Indoor dBA levels of DC-10 4.0 km from touchdown - time history.

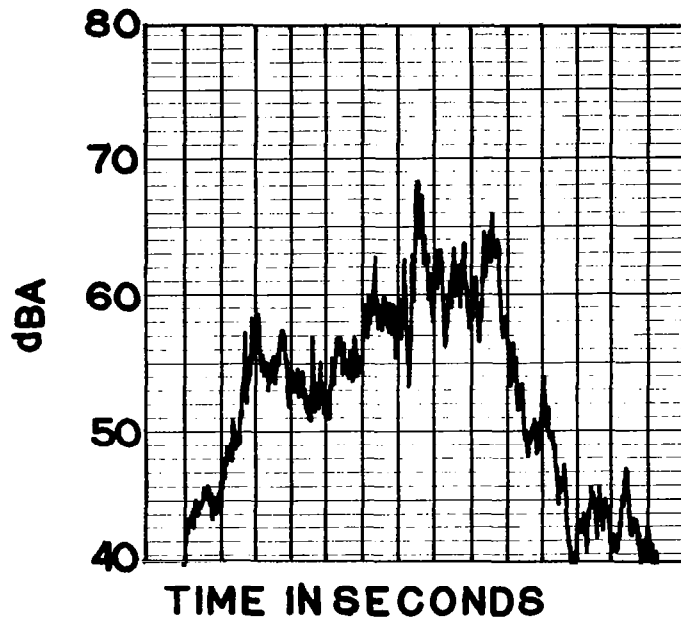

Figure 17.- Indoor dBA levels of 707 8.4 km from touchdown - time history.

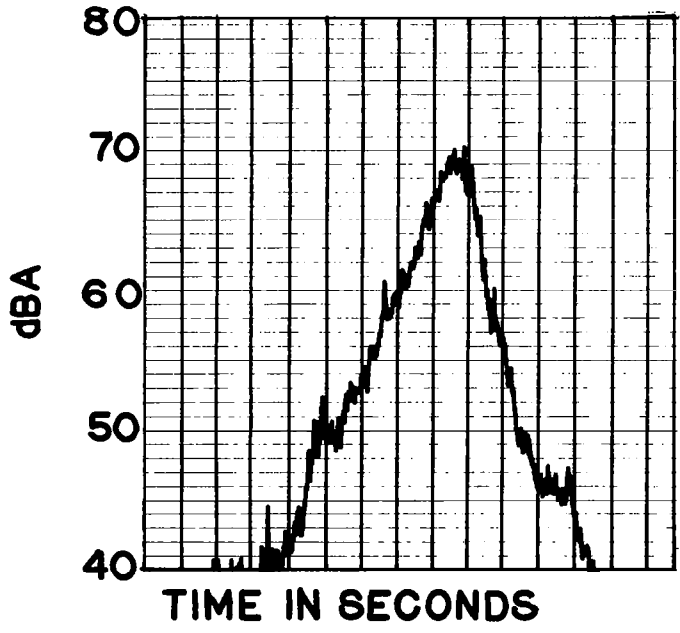

Figure 18.- Indoor dBA levels of 747 8.4 km from touchdown - time history.

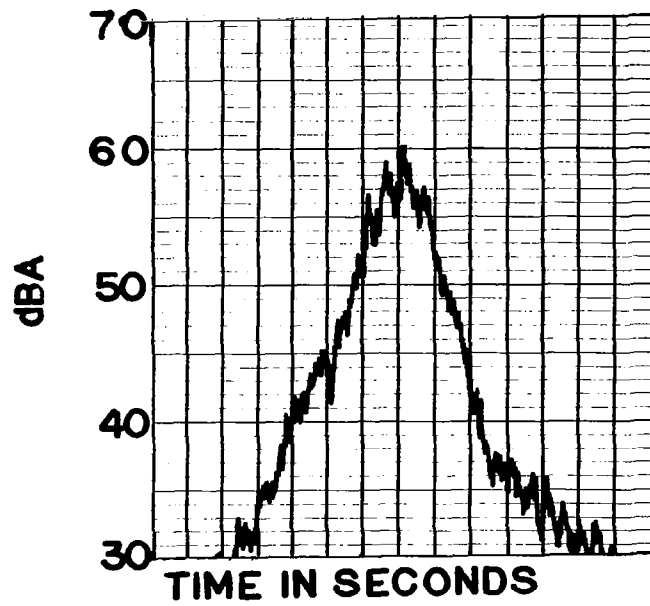

Figure 19.- Indoor dBA levels of 727 8.4 km from touchdown - time history.

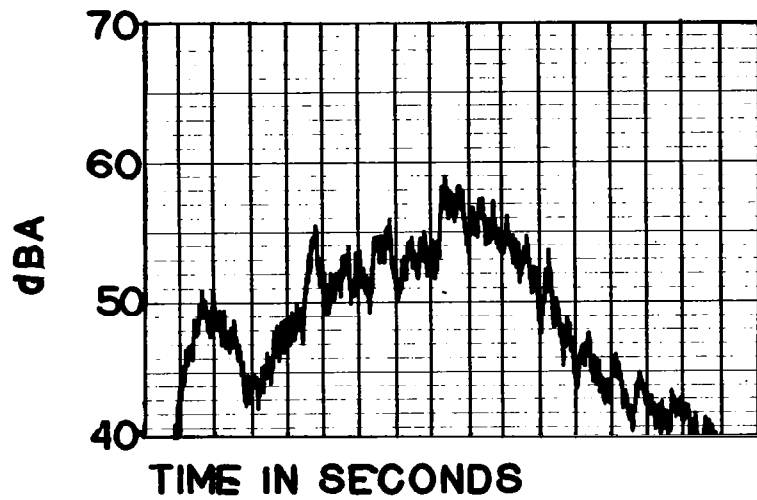

Figure 20.- Indoor dBA levels of DC-10 8.4 km from touchdown - time history.

A number of further observations may be made from Table 10. The standard deviations of the means (σ) are generally greater for the field interview responses, ranging generally above 3 points on the annoyance scale. The exception is for the high fear group, where the standard deviation is generally less than two points. This is as expected, since the variations in the real environment stimuli are so great and are probably perceived differently by various residents who are not usually present in their homes doing the same things at the same time. High fear residents who generally have a more intense field annoyance response, almost double that of low fear residents, also have less variability in annoyance related to degree of physical exposure. Even at relatively lower noise levels, high fear residents report high annoyance. Consequently, it is not surprising that they have a smaller standard deviation. As will be seen in the next section on correlation analyses, the high standard deviation of the field interviews tends to reduce the level of correlations between field and laboratory responses.

D. Correlation Analyses of Reported Annoyance in Field and Laboratory Environments

1. Difficulties Involved in Comparing Field Responses to Simulated Field Conditions in a Laboratory

When a resident is interviewed in the field and reports a single summated feeling of annoyance to TV interference, it is obvious that he somehow is integrating many different experiences over unknown periods of time. As discussed in Section B, "Description of Aircraft Noise Exposures", the number, mix of aircraft and level of noise varied considerably from day to day and month to month. Tables 8 and 9 describe these variations for only the evening hours, when it is assumed most adult TV viewing occurs. However, the variations in aircraft operations and noise exposures are even greater in other time periods of the day and it is possible that there are time lag effects of exposures from other time periods that make the problem of replication very complex. ^{15/} Since a laboratory test must necessarily limit the number of variables it can study in a single experiment, it is most difficult to replicate even approximately the complexities of the real environment.

TABLE 10

MEAN ANNOYANCE REPORTS WITH TV INTERFERENCE
IN THE FIELD INTERVIEW AND LABORATORY

A. All Areas	Field Interview		S T I M U L U S G R O U P							
	\bar{X}	σ	S1	S2		S3		S4		
Fear Group	\bar{X}	σ	\bar{X}	σ	\bar{X}	σ	\bar{X}	σ	\bar{X}	σ
Low (N=72)	4.5	3.5	4.0	2.6	4.5	2.4	5.4	2.5	6.8**	2.3
Medium (N=72)	6.0	3.2	4.3**	2.6	5.1	2.5	6.5	2.3	7.7**	1.7
High (N=72)	8.4	1.6	4.9**	2.7	5.4**	1.6	6.8**	2.1	8.0	1.3
Total (N=216)	6.3	3.3	4.4**	2.7	5.0**	2.5	6.2	2.4	7.5**	1.9
B. Rosedale (close)										
Fear Group	\bar{X}	σ	\bar{X}	σ	\bar{X}	σ	\bar{X}	σ	\bar{X}	σ
Low (N=24)	5.9	3.3	3.8*	2.6	5.2	2.4	6.0	2.5	7.5	2.1
Medium (N=24)	6.0	3.5	3.9*	2.0	6.1	2.0	7.0	1.9	8.1*	1.3
High (N=24)	8.6	1.3	4.4**	2.4	5.7**	2.2	7.3**	1.7	8.3	1.1
Total (N=72)	6.8	3.1	4.0**	2.4	5.7**	2.2	6.8	2.1	8.0**	1.6
C. Laurelton (middle)										
Fear Group	\bar{X}	σ	\bar{X}	σ	\bar{X}	σ	\bar{X}	σ	\bar{X}	σ
Low (N=24)	3.0	3.1	4.3	2.6	5.3**	2.1	6.0**	2.0	7.0**	2.1
Medium (N=24)	6.0	3.4	4.6	2.6	5.0	2.8	6.9**	2.1	7.8*	1.6
High (N=24)	8.1	2.0	5.5**	2.9	6.8*	2.2	7.6	1.8	8.5	1.0
Total (N=72)	5.7	3.6	4.8	2.7	5.7	2.5	6.8*	2.1	7.7**	1.7
D. Floral Park (Distant)										
Fear Group	\bar{X}	σ	\bar{X}	σ	\bar{X}	σ	\bar{X}	σ	\bar{X}	σ
Low (N=24)	4.5	3.4	3.9	2.7	3.2	2.1	4.3	2.4	6.0	2.5
Medium (N=24)	6.2	2.7	4.4*	3.0	4.2**	2.3	5.6	2.5	7.1	1.9
High (N=24)	8.5	1.3	4.7**	2.6	3.7**	2.2	5.3**	2.0	7.2**	1.4
Total (N=72)	6.4	3.1	4.3**	2.8	3.7**	2.2	5.1**	2.4	6.8	2.1

* "t" test significant at p.05 level

** "t" test significant at p.01 level

It has already been noted that the mix of aircraft in the laboratory tapes overstated somewhat the numbers of 707 and 747 aircraft and correspondingly, understated the numbers of 727 and DC-10 flyovers. Likewise, tape S2, (6 flyovers) which was designed to represent an average number of actual flyovers, in fact, was 2½ flights too low, on the average for the July-October period and as much as 3 flights too low when compared to actual operations for July-August. In a similar fashion, the S3 tape (12 flyovers) which was designed to test reactions to the peak number of daily exposures was 3 flights too low on the average and 4 flights too low in relation to July-August operations. Despite these discrepancies, however, tape 2 is most nearly like the actual average exposure and tape 3 is closest to the peak exposures. Tape 4 has clearly more operations than experienced in any single day during the four-month period July-October 1975.

Some general difficulties inherent in efforts to match field and laboratory responses have been discussed by Carl Hovland and other sociologists. 16/ Four major differences are applicable to our specific study. First, in the real environment a resident is self-selective in the attention he gives to varying stimuli over time. It is known that persons with high fear of possible crashes pay more attention to successive overflights than persons with low fear. In fact, residents with low fear do not consciously even hear many overflights when they are preoccupied with other activity. The meaning of the aircraft noise is known to the resident and since it occurs repetitively, there is no compelling reason for the low fear person to pay continuing attention to the aircraft noise. In a recent field study 15/, 84% of the high fear residents said that they pay attention to almost every time an airplane flies overhead until it passes, compared to less than a third of all residents expressing little or no fear of crashes. About half of the medium fear residents also pay attention to almost all flyovers. The process, which we define as adaptation, involves this very submergence of the aircraft noise into the undifferentiated ambient noise. A person with high fear, on the other hand, despite all past safe overflights, needs to detect, evaluate and be reassured that each flight will present no imminent danger.

In contrast to the real environment situation, in the laboratory, the subject is fully exposed to all the controlled stimuli, and is more aware of them than in his own home. In fact, he is told that he will be asked to judge the stimuli and therefore, has an incentive to pay more attention to them.

A second important problem is that the entire complex of stimuli exists in the real environment while only a selected portion of it can be presented in a limited laboratory experiment. This limitation has already been discussed, i.e. only four stimulus tapes could be realistically presented. The real environment summated judgement includes many days of no operations and more varying numbers and mixes of aircraft.

A third significant difference is the time frame for the judgements. In the real world, the single judgement given to the interviewer may reflect years of exposure and reactions, even though the question is asked only about the past summer months. Overflights during the more immediate fall months of September and October may also have unconsciously influenced the interview response, since the judgement was given during the fall months. It is even possible that some unusual intense exposures in the more distant past had a lingering effect on a current judgement. In the laboratory, on the other hand, only a limited period of 30-minutes could be allocated to each experimental situation. This difference in duration of exposure could be very important.

A fourth variable involves the differences in social contexts of the field and laboratory judgements. In the field, there is possible interaction and social reinforcement of peer groups which may affect the respondent's answers. In the laboratory the sponsorship of the study, the beliefs by the subjects of the points of view of the study staff and the feelings transmitted to the subject about the nature and importance of the study, undoubtedly influence laboratory judgements. A discussion of these situational factors was presented in greater detail in a previous research report 12/.

Considering all of the above difficulties inherent in matching field and laboratory responses, it is somewhat surprising to find the degree of relationships which are found in Tables 10 and 11.

2. Correlations Between Field Interviews and Controlled Laboratory Reports of Annoyance

Contrary to many prevailing assumptions, integrated field annoyance appears less related to any simple averaging of widely varying physical exposures and more related to the most intense "worst" day experiences. As Table 11 indicates, there is a fairly consistent pattern in which the best correlations between field TV annoyance responses appear to be with S3 or approximate peak experience exposures. Considering all subjects, the correlation coefficient for these two responses is $r=.25$, which is significant at the $p.01$ level. Likewise, as shown in Table 10, a "t" test of these two means shows no significant differences (field mean = 6.3; S3 mean = 6.2). The prediction equation for this relationship is $y_1 = 4.14 + .35x$, where X is the S3 laboratory value and Y is the predicted field response. The correlation coefficient for the field and S3 responses for all medium fear subjects is $r=.34$, which is even higher. Likewise, for the middle and distant medium fear subjects, it is $r=.56$ and $.51$ respectively.

Correlations between S1 and S2 exposures and field annoyance reports were generally not significant. Correlation between S4 exposures and field annoyance reports for all subjects was $r=.28$, but the two means as shown in Table 10 were significantly different ($p < .01$). The overall mean annoyance for S4 exposures was 7.5, while the corresponding field TV annoyance was only 6.3. Consequently, it is reasonable to conclude that the best correlation between reported integrated field TV annoyance and laboratory judgements is the peak level of exposures (S3).

The above conclusion suggests that in the complex field environment, residents appear to base their integrated annoyance responses more on their worst experiences rather than on some type of simple averaging of widely varying numbers of experiences. This "worst experience" hypothesis is further supported by correlations between overall aircraft annoyance which encompasses interference with all kinds of activity besides TV, reported during the interview and annoyance reported in the laboratory for the S3 and S4 stimuli. The correlation between overall aircraft noise annoyance reported in the context of all other noises heard in the area and the S3 laboratory annoyance reports for all subjects is $r=.29$. These data will be discussed in a subsequent section of the report.

E. The Effects of Reported Feelings of Fear and Number of Aircraft Flyovers on Annoyance

There is little doubt that annoyance is generally less when there are fewer noise exposures of comparable noise levels and the subjects have less fear of aircraft crashes. All statistical tests consistently support these conclusions. A

TABLE 11

CORRELATIONS BETWEEN FIELD INTERVIEW AND LABORATORY REPORTS OF
ANNOYANCE WITH INTERFERENCE OF TV BY AIRPLANE NOISE

A. All Areas

<u>Fear Group</u>	<u>S T I M U L U S G R O U P</u>			
	<u>S1</u>	<u>S2</u>	<u>S3</u>	<u>S4</u>
Low (N=72)	-.01	-.03	.04	.22
Medium (N=72)	.20	.19	.34**	.18
High (N=72)	.11	.01	.17	.09
Total (N=216)	.14*	.12	.25**	.28**

B. Close

<u>Fear Group</u>				
Low (N=24)	.17	.18	.38	.42*
Medium (N=24)	.05	.03	.03	-.27
High (N=24)	.32	.30	.58**	.10
Total (N=72)	.17	.12	.30**	.18

C. Middle Distance

<u>Fear Group</u>				
Low (N=24)	-.03	-.09	.21	.23
Medium (N=24)	.14	.22	.56**	.28
High (N=24)	.08	-.22	-.03	-.03
Total (N=72)	.15	.16	.42**	.36**

D. Distant

<u>Fear Group</u>				
Low (N=24)	-.09	-.20	.42*	.02
Medium (N=24)	.43*	.41*	.51*	.53**
High (N=24)	.09	.26	.30	.31
Total (N=72)	.17	.13	.12	.31**

* significant at p.05
** significant at p.01

two-way analysis of variance of the laboratory responses, "t" tests of field interview responses and correlation analysis of field and laboratory data all indicate these conclusions are valid.

Table 12 presents an analysis of variance between fear and number of flyovers. The effect of number of flyovers is significant at the 1% level in all tests. The effect of fear is also significant at the 1% level in all cases except the close area, where it is significant at the 5% level. It must be recalled that the close area subjects with low fear had an upward bias in their field responses of annoyance. This undoubtedly contributes to the somewhat lower level of significance in this one category.

Table 13 presents the mean annoyance scores for all four stimulus sessions by fear group. Scheffé tests of differences between mean annoyance reports indicate that: 17/

1. Annoyance reported by low fear subjects is significantly less than annoyance by high fear subjects in all areas and overall for all subjects.
2. Annoyance reported by low fear subjects is significantly less than annoyance reported by moderate fear subjects in close and distant areas and for all subjects, but not for middle distance subjects.
3. Annoyance reported by moderate fear subjects is not generally different from high fear subjects. Only in the case of the middle distance are these means different.

Table 14 presents the mean annoyance scores for all fear groups combined by laboratory stimulus groups. Scheffé tests of differences between mean annoyance reports indicate that for all distance groups combined and separately except for the distant group, the mean annoyances are significantly greater as the number of exposures increases, i.e. $S_4 > S_3 > S_2 > S_1$. For the far distance group, the annoyance pattern is $S_4 > S_3 > S_1 > S_2$.

When the number of exposures in each stimulus group is correlated with the appropriate subject annoyance reports for all 216 subjects, a highly significant correlation coefficient of $r=.42$ is obtained. The regression equation for this relationship between 3, 6, 12 and 24 exposures and annoyance is $y_1 = 4.20 + .14x$.

Some further evidence of the significant effects of feelings of fear on annoyance responses are shown in Tables 15 and 16. Table 15 shows field interview reports of TV annoyance for subjects and non-participants, by fear group. "T" tests of differences between mean annoyance responses indicate that in all but one comparison there are significant differences in annoyance reports by fear group; the more fear, the greater annoyance. The one exception, as expected, is for the close area subjects, where annoyance by low and medium fear groups are the same. The close area subjects with reported low fear were found to have an upward bias in their fear responses when compared to non-cooperating residents (Table 7).

Table 16 shows a similar comparison for total aircraft noise annoyance reported on the field interviews. Total annoyance 12/ is a composite index of interferences with 11 activities and has a range in scores of 0-99. "T" tests of differences between means indicates that in all comparisons for subjects and non-subjects, the greater the fear, the greater the overall annoyance levels. The statistical significance level of the differences is generally at the 1% level.

TABLE 12

TWO-WAY ANALYSIS OF VARIANCE
FEAR BY NUMBER FLYOVERS

A. All Subjects

<u>Source of Variation</u>	<u>Sum of Squares</u>	<u>Degree of Freedom</u>	<u>Mean Square</u>	<u>F Ratio</u>
Fear	23.422	2	11.711	15.04**
No. Flyovers	174.350	3	58.117	74.65**
Interaction	1.937	6	.323	.415
Within Groups	663.292	852	.779	-

B. Rosedale (close)

<u>Source of Variation</u>	<u>Sum of Squares</u>	<u>Degree of Freedom</u>	<u>Mean Square</u>	<u>F Ratio</u>
Fear	5.209	2	2.604	3.86*
No. Flyovers	93.836	3	31.279	46.32**
Interaction	1.585	6	.264	.391
Within Groups	186.371	276	.675	-

C. Laurelton (middle)

<u>Source of Variation</u>	<u>Sum of Squares</u>	<u>Degree of Freedom</u>	<u>Mean Square</u>	<u>F Ratio</u>
Fear	17.094	2	8.547	11.03**
No. Flyovers	54.071	3	18.024	23.27**
Interaction	2.031	6	.339	.44
Within Groups	213.804	276	.775	-

D. Floral Park (Distant)

<u>Source of Variation</u>	<u>Sum of Squares</u>	<u>Degree of Freedom</u>	<u>Mean Square</u>	<u>F Ratio</u>
Fear	7.976	2	3.988	4.93**
No. Flyovers	54.599	3	18.200	22.51**
Interaction	1.299	6	.216	.27
Within Groups	223.127	276	.808	-

* significant at p.05
** significant at p.01

TABLE 13

MEAN LABORATORY ANNOYANCE RESPONSES
BY FEAR OF AIRCRAFT CRASHES

<u>Fear Level</u>	<u>All Subjects</u>	<u>D I S T A N C E O F R E S I D E N C E</u>		
		<u>Close</u>	<u>Middle</u>	<u>Distant</u>
Low	5.20	5.64	5.63	4.33
Medium	5.89	6.27	6.07	5.32
High	6.25	6.44	7.11	5.21

TABLE 14

MEAN LABORATORY ANNOYANCE RESPONSES
BY NUMBER OF FLYOVERS

<u>Number of Flyovers</u>	<u>All Subjects</u>	<u>D I S T A N C E O F R E S I D E N C E</u>		
		<u>Close</u>	<u>Middle</u>	<u>Distant</u>
S1 (3)	4.38	4.01	4.81	4.32
S2 (6)	5.01	5.65	5.71	3.67
S3 (12)	6.24	6.81	6.83	5.07
S4 (24)	7.50	7.99	7.74	6.76

TABLE 15

REPORTED MEAN TV ANNOYANCE IN FIELD SURVEY
BY FEAR GROUPS OF RESIDENTS

<u>Area</u>	<u>Subjects</u>			<u>Non-Participants</u>		
	<u>F E A R G R O U P</u>			<u>F E A R G R O U P</u>		
	<u>Low</u>	<u>Medium</u>	<u>High</u>	<u>Low</u>	<u>Medium</u>	<u>High</u>
Close	5.9	6.0	8.6	4.1	6.5	8.3
Middle Distance	3.0	6.0	8.1	4.1	5.5	7.6
Distant	4.5	6.2	8.5	4.8	5.8	8.3

TABLE 16

REPORTED TOTAL AIRPLANE NOISE ANNOYANCE IN FIELD SURVEY
BY FEAR GROUPS OF RESIDENTS

<u>Area</u>	<u>Subjects</u>			<u>Non-Participants</u>		
	<u>F E A R G R O U P</u>			<u>F E A R G R O U P</u>		
	<u>Low</u>	<u>Medium</u>	<u>High</u>	<u>Low</u>	<u>Medium</u>	<u>High</u>
Close	21.6	32.5	68.7	20.4	33.7	63.0
Middle Distance	11.5	30.2	58.1	16.7	24.9	54.6
Distant	18.0	35.8	65.5	20.2	31.4	62.4

Since most cumulative noise indexes such as CNR, NEF, L_{dn} and L_{eq} , all assume that single noise events are combined on an energy basis, it was decided to calculate the L_{eq} values for each of the four half-hour segments for the sessions of each distance group and to correlate these L_{eq} values with the laboratory annoyance responses. The ambient noise level, which was determined by the TV programs, averaged 60 dBA at each session. As figures 9-20 indicate, the duration for each fly-over above 60 dBA was relatively brief, ranging from 17 seconds for the close DC-10 to 0 for the distant DC-10. The different durations above ambient for each plane type are shown in Table 17.

TABLE 17
DURATION IN SECONDS OF FLYOVERS ABOVE AMBIENT

Plane Type	Distance of Residence from Runway		
	Close	Middle	Distant
707	13	10	4
747	7	6	3
727	5	3	1
DC-10	17	6	0

The formulas used for calculating L_{eq} were as follows: $\frac{18}{10} \left[\frac{\Delta L}{10} - 1 \right]$

$$L_{eq} \text{ for single event} = L_b + 10 \log \left[\frac{10}{2.3 \Delta L} \left(10^{\frac{\Delta L}{10}} - 1 \right) \right]$$

Where L_b is the ambient and ΔL is the difference between peak dBA and ambient dBA.

$$L_{eq} \text{ for 30-minute segment} = 10 \log \left[\frac{T_1}{T} 10^{\frac{L_1}{10}} + \frac{T_2}{T} 10^{\frac{L_2}{10}} + \dots + \frac{T_n}{T} 10^{\frac{L_n}{10}} \right]$$

The computed L_{eq} values for each segment is shown in Table 18:

TABLE 18
COMPUTED L_{eq} VALUES FOR EACH LABORATORY SEGMENT

Stimulus Group	Distance of Residence from Runway		
	Close	Middle	Distant
S1	63.1	61.1	60.1
S2	64.3	61.3	60.1
S3	66.4	62.7	60.2
S4	68.8	64.3	60.3

As can be seen, the L_{eq} values have only a fairly small variation due to the relatively brief time airplane noise exceeds the ambient. The overall correlation between L_{eq} and annoyance for all 864 judgements of the 216 subjects is $r = .35$. The regression equation is $Y = -16.1 + .35X$, where Y is the predicted annoyance and X is the L_{eq} value.

It is interesting to note that the overall correlation between simply number of exposures (3, 6, 12, 24) and annoyance is $r = .42$. Apparently, any index which systematically includes number and level of peak exposure produces a very significant correlation. But since the L_{eq} somewhat suppresses the importance of numbers of exposure, the simple direct correlation of number of flyovers and annoyance is greater.

F. Relationships of Selected Attitudes and Personal Variables on Laboratory and Field Annoyance Responses

Table 19 presents a summary of correlations of a number of personal variables and laboratory and field annoyance responses for all 216 subjects used in the laboratory experiment. Similar correlations were computed for each sample area and the results are comparable.

It should be noted that of all the laboratory test stimuli, the S3 and S4 laboratory annoyance responses have the highest and most significant correlations with the selected attitude and personal variables which have been established as most relevant. This further underscores the findings of section D2 that the summated TV field annoyance is more related to "worst" case exposures than to a simple averaging of experiences.

Secondly, fear is significantly related to all laboratory and field annoyance responses. The correlations are highest with field reports of TV annoyance ($r=.51$) and total field aircraft annoyance ($r=.67$). Apparently the problems inherent in a laboratory setting somewhat reduce the magnitude of the effects of fear on laboratory judgements of annoyance but not its statistical significance.

Third, misfeasance also appears to have a highly significant relationship to the S4 stimulus, and an even more significant relationship to the field interview annoyance responses. Sex and income levels of residents have relatively less significance with respect to interview annoyance responses. Field total annoyance responses are highly intercorrelated with field TV annoyance and with S3 and S4 laboratory annoyance judgements. This is consistent with the other findings.

Beliefs that the aircraft noise has harmful health effects also has a highly significant relationship to annoyance, both in the laboratory and in field reports. A special analysis which further describes these "health effects" is shown in Table 20. All subjects who reported some harmful health effects were asked Q.25B, "In what way is aircraft noise harmful to health?" It should be noted that belief in harmful health effects is also strongly related to fear of crashes. Only 26% of the low fear subjects compared to 90% of the high fear subjects reported harmful health effects of aircraft noise. The more frequent types of health effects mentioned are creation of tension, harm to hearing, disturbing sleep and communication and adding to fear.

G. Reported Retrospective Comparisons of Laboratory Stimuli and Home Environments

As described in the explanation of laboratory procedures, at the end of each half hour stimulus presentation, each subject was asked to judge the stimulus just heard in relation to his home environment. This was a very difficult task for many subjects because they said that their home airplane exposures varied so much, that they didn't know what was "a general situation". Moreover, a number of subjects found it a problem to recall the exposures during the evening hours as compared to other time periods, and our instructions were to focus on the evening hours. Their difficulties are realistic reflections of the actual variability in operating conditions as described in Tables 8 and 9. Nevertheless, despite the considerable differences among answers by subjects, the general pattern of answers appears related to actual exposure conditions. The variations in subjects' ability to accurately recall their home exposures undoubtedly contributed to lower correlations between field and laboratory responses. Table 21 presents the subject comparisons of laboratory noise exposures with their home environments.

TABLE 19

CORRELATIONS BETWEEN PERSONAL VARIABLES
AND ANNOYANCE RESPONSES FOR ALL SUBJECTS

	<u>LABORATORY STIMULUS GROUP</u>				<u>TV</u>	<u>Total</u>
	<u>S1</u>	<u>S2</u>	<u>S3</u>	<u>S4</u>	<u>Field</u>	<u>Annoyance</u>
N=216						
Fear	.16*	.14*	.22**	.26**	.51**	.67**
Health	.02	.04	.07	.13*	.23**	.29**
Misfeasance	.27**	.22**	.20**	.26**	.48**	.62**
Sex	.03	.12	.07	.07	-.12	-.15*
Income	-.10	-.07	-.11	-.11	-.14*	-.15*
A/C annoyance in noise context	.25**	.16*	.29**	.25**	.58**	.66**
TV field annoyance	.14*	.12	.25**	.28**	1	.71**
Total field annoyance	.17**	.12	.21**	.27**	.71**	1

* significant at p.05 level

** significant at p.01 level

TABLE 20

REPORTED WAYS AIRCRAFT NOISES ARE BELIEVED
HARMFUL TO HEALTH

	<u>F E A R G R O U P</u>							
	<u>Low</u>		<u>Medium</u>		<u>High</u>		<u>Total</u>	
	<u>No.</u>	<u>%</u>	<u>No.</u>	<u>%</u>	<u>No.</u>	<u>%</u>	<u>No.</u>	<u>%</u>
Total Subjects	72	100%	72	100%	72	100%	216	100%
Not harmful or don't know if harmful	53	74	23	32	7	10	83	38
Believed harmful	19	26	49	68	65	90	133	62
In What Way? ^{1/}		100%		100%		100%		100%
General pollution		15.8		6.1		13.8		11.3
Create tension		36.8		69.4		64.6		62.4
Hurts hearing		36.8		40.8		38.5		39.1
Non-auditory health effects		15.8		4.1		7.7		7.5
Distracting		10.5		8.2		4.6		6.8
Disturbs sleep		10.5		4.1		15.4		10.5
Disturb communication		0		6.1		10.8		7.5
Adds to fear		0		0		15.4		7.5
General annoyance		10.5		0		0		1.5

^{1/} Percentages do not add to 100% since more than one reason may be given.

TABLE 21

LABORATORY STIMULI CONDITIONS COMPARED TO USUAL HOME CONDITIONS

Question	Laboratory/Home Percent	S T I M U L U S C O N D I T I O N															
		1				2				3				4			
		F E A R G R O U P				F E A R G R O U P				F E A R G R O U P				F E A R G R O U P			
		Low	Med.	High	Total	Low	Med.	High	Total	Low	Med.	High	Total	Low	Med.	High	Total
C1-Number Flights	more	11%	3%	0%	5%	25%	14%	0%	13%	40%	32%	15%	29%	61%	57%	33%	50%
	same	26	26	17	23	32	30	28	30	40	40	36	39	26	36	49	37
	less	63	71	83	72	43	56	72	57	20	28	49	32	13	17	18	13
C2-Noise Level	more	38	28	17	27	38	22	11	24	43	42	12	32	54	54	29	46
	same	39	46	50	45	33	45	36	38	35	46	60	47	36	36	61	44
	less	23	26	33	28	29	33	53	38	22	12	28	21	10	10	10	10
C3-Annoyance	more	25	11	1	13	33	15	6	18	40	38	11	30	63	60	35	52
	same	31	35	40	35	35	42	36	38	40	46	58	48	22	35	54	37
	less	44	54	59	52	32	43	58	44	20	16	31	22	15	5	11	11

With respect to comparisons of the number of laboratory flights and the number usually heard at home, 72% of all subjects correctly said, "less" for S1, but 57% also said "less" for S2, which was closest to the average. The distribution for S3 was almost equally divided among all three choices, but a small plurality of 39% said "same". This response is consistent with our correlation analyses in which annoyance with S3 was most closely related to the field interview annoyance reports. Likewise, 50% said S4 was "more" than their home experience, which is also in accord with reality. But 37% said S4 (24 flyovers per half hour) was the "same" and 13% said it was even "less" than their usual home experiences. This distortion of recall of the home environment must have contributed to the greater variability in annoyance responses and reduced correlations between laboratory and field annoyance responses.

It is of interest to note that the greater the fear of crashes, the greater the distortion; 49% of the high fear group said S3 was "less" and 18% said S4 was "less" than usual operations. Correspondingly, more of the low fear group consistently felt the number of laboratory exposures was more than they usually experienced. This supports our previous discussion that low fear subjects usually pay less attention to their home airplane exposures.

Chi-square tests of the distributions of answers for each stimulus group indicate that answers to each stimulus group are significantly different from one another, at the 1% level of significance. This was also true for all fear groups, with one exception that for the high fear group, the answers to S1 and S2 were not significantly different. Table 22 presents these findings.

With respect to the question on noise levels, a chi-square test indicates that subjects judged S1 and S2 exposures and S1 and S3 exposures about the same, but S1 was judged less noisy than S4 and S2 less noisy than S3 and S4. Likewise, S3 was judged less noisy than S4. It is unfortunate that the subjects were not asked to describe their interpretations of noisy. Did they consider the individual types of airplane noise levels, or did they utilize some way of aggregating the individual flights? Nevertheless, almost half of all subjects judged S3 as about "equal" to their usual environment at home, i.e. the approximate peak noise exposure. Likewise, 44% said S4 was "equal" and 46% said "more" than their usual exposure.

Lastly, an evaluation of answers on comparative annoyance, indicates that answers to S1 and S2 are not significantly different, but answers to all other stimulus groups are different at the 1% level of significance. It is important to note again the reinforcement of our previous conclusion that annoyance with S3 is best related to the real environment situation. Almost half of all subjects said their annoyance with S3 was about the same as their usual annoyance at home and 52% said S4 was more than their home experiences. Table 22 presents the detailed chi-square comparisons of answers presented in Table 21.

H. Annoyance and Acceptability Judgements

The 216 subjects made 864 annoyance judgements of laboratory stimuli. As shown in Table 23, and Figure 21, they do not expect a stressless environment. Annoyance levels of 0-2 are reported acceptable by practically all persons, while annoyance levels of 3-4 are acceptable to about 80% of all persons. Annoyance levels of 5-6 appear to be the median levels, where about half the subjects say they can live with that level of annoyance and half cannot. Annoyance intensities above levels 7-9 are clearly acceptable to relatively few residents and not acceptable to most. Table 23 and Figure 21 present these findings.

TABLE 22

CHI-SQUARE TESTS OF DISTRIBUTIONS OF ANSWERS
TO JUDGEMENTS OF LABORATORY AND HOME EXPOSURES

A. All Subjects (N=216)

<u>C1 - Number Flights</u>	<u>Significance Level</u>	<u>Chi-Square</u>
S1 vs S2	**	13.90
S1 vs S3	**	80.75
S1 vs S4	**	180.22
S2 vs S3	**	31.84
S2 vs S4	**	111.98
S3 vs S4	**	30.77
 <u>C2 - Noise Level</u>		
S1 vs S2	not significant	5.54
S1 vs S3	not significant	3.16
S1 vs S4	**	28.91
S2 vs S3	**	16.24
S2 vs S4	**	53.42
S3 vs S4	**	13.83
 <u>C3 - Annoyance</u>		
S1 vs S2	not significant	3.72
S1 vs S3	**	45.64
S1 vs S4	**	112.49
S2 vs S3	**	24.93
S2 vs S4	**	80.81
S3 vs S4	**	25.50

B. Low Fear Group

<u>C1 - Number Flights</u>		
S1 vs S2	*	6.8
S1 vs S3	**	30.29
S1 vs S4	**	48.92
S2 vs S3	**	9.69
S2 vs S4	**	23.38
S3 vs S4	*	6.25
 <u>C2 - Noise Level</u>		
S1 vs S2	not significant	.73
S1 vs S3	not significant	.48
S1 vs S4	*	6.42
S2 vs S3	not significant	.97
S2 vs S4	**	9.26
S3 vs S4	not significant	4.46
 <u>C3 - Annoyance</u>		
S1 vs S2	not significant	2.52
S1 vs S3	**	10.58
S1 vs S4	**	22.77
S2 vs S3	not significant	2.96
S2 vs S4	**	12.60
S3 vs S4	*	7.58

TABLE 22 (Cont.)

C. Medium Fear Group

<u>C1 - Number Flights</u>	<u>Significance Level</u>	<u>Chi-Square</u>
S1 vs S2	*	6.52
S1 vs S3	**	33.26
S1 vs S4	**	74.25
S2 vs S3	**	13.63
S2 vs S4	**	47.55
S3 vs S4	**	14.23
 <u>C2 - Noise Level</u>		
S1 vs S2	not significant	1.04
S1 vs S3	not significant	5.58
S1 vs S4	**	12.49
S2 vs S3	**	11.09
S2 vs S4	**	19.56
S3 vs S4	not significant	2.25
 <u>C3 - Annoyance</u>		
S1 vs S2	not significant	1.84
S1 vs S3	**	25.71
S1 vs S4	**	52.51
S2 vs S3	**	15.28
S2 vs S4	**	40.24
S3 vs S4	*	8.76

D. High Fear Group

<u>C1 - Number Flights</u>		
S1 vs S2	not significant	2.57
S1 vs S3	**	22.74
S1 vs S4	**	65.52
S2 vs S3	**	15.10
S2 vs S4	**	52.97
S3 vs S4	**	16.24
 <u>C2 - Noise Level</u>		
S1 vs S2	not significant	5.57
S1 vs S3	not significant	1.41
S1 vs S4	**	12.58
S2 vs S3	**	9.83
S2 vs S4	**	31.81
S3 vs S4	**	11.07
 <u>C3 - Annoyance</u>		
S1 vs S2	not significant	1.96
S1 vs S3	**	14.07
S1 vs S4	**	46.74
S2 vs S3	**	12.51
S2 vs S4	**	40.93
S3 vs S4	**	15.40

* p.05 = 5.99
 ** p.01 = 9.21

TABLE 23

REPORTS OF ANNOYANCE AND ACCEPTABILITY REPORTED IN LABORATORY JUDGEMENTS

<u>Annoyance Level</u>	<u>Number Annoyance Judgements</u>	<u>A C C E P T A B I L I T Y</u>	
		<u>Yes</u>	<u>No</u>
9	171	3.5%	96.5%
8	125	6.4	93.6
7	103	28.2	71.8
6	100	47.0	53.0
5	95	57.9	42.1
4	78	78.2	21.8
3	58	79.3	20.7
2	67	92.5	7.5
1	37	97.3	2.7
0	<u>30</u>	<u>100.0</u>	<u>0</u>
Total	864		

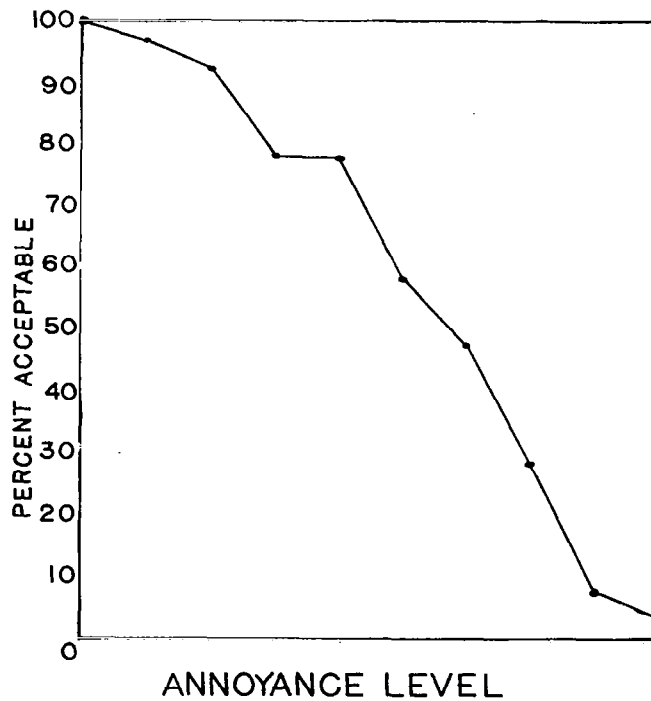

Figure 21.- Comparison of annoyance and acceptability judgments.

The decision of what is an acceptable noise exposure is a political issue and not a purely technical question. How much protection should be provided to how many people is clearly a question for government regulations. Scientific research, however, has a role in providing data on the likely relationships between physical noise exposures and probable annoyance and acceptability responses by different populations. The data produced by this study are highly suggestive of what the thresholds of acceptability are likely to be, and the following discussion outlines some of the implications of the findings.

The major objective of this study was to test the relationships between responses in the laboratory and a field survey. Consequently, the experimental design limited the flyover noise exposure levels judged by each group of subjects to only those nominal levels estimated to be typical for its location. Close distance subjects did not express their annoyance and acceptability reactions to middle distance or distant area noise exposure levels. As a result, it is not possible from these data to develop a generalized statistical model of subject reactions to all combinations of numbers and noise levels of exposure. A separate experiment is needed to derive such findings. The results of this study, however, will provide valuable insights and assist in the appropriate design of such further research.

First, a re-examination of Tables 1 and 2 indicates that the 707 and 747 aircraft, which are by far the largest and noisiest of the planes studied, also dominated the number of exposures in each stimulus group. These two planes represented 100% of all S1 exposures and about 70% of all other stimulus group exposures. The peak dBA noise levels for these planes were about 84 for the close areas, 80 for the middle distance and 70 for the distant areas.

Then, if we accept the present findings and assume that an annoyance score of 5 or more is generally not acceptable to most residents and a score of less than 5 is acceptable, then the following observations may be made from the mean annoyance reports listed in Table 10.

Considering subjects from all areas combined:

1. Low fear residents with high predispositions to accommodate noise reported:
 - a. their home annoyance acceptable (mean = 4.5)
 - b. S1 and S2 noise exposures are also acceptable (means of 4.5 and 4.0)
 - c. S3 noise exposures (9 of 12 exposures are the noisy 707 and 747) are not acceptable (mean 5.4) to about half of all subjects.
 - d. S4 exposures (17 of 24 exposures are the 707-747) are definitely not acceptable (mean of 6.8)
2. Medium fear residents with moderate predispositions to accommodate noise reported:
 - a. their home annoyance is not acceptable (mean of 6.0)
 - b. S1 exposures are acceptable (mean of 4.3)
 - c. S2 exposures marginally not acceptable (mean of 5.1) to about half of all subjects
 - d. S3 and S4 definitely not acceptable (means of 6.5 and 7.7)

3. High fear residents with low predispositions to accommodate noise reported:

- a. their home environment is definitely not acceptable (mean of 8.4)
- b. stimulus S1 is marginally not acceptable (mean 4.9) to half of all subjects.
- c. stimulus S2-S4 are definitely not acceptable (means of 5.4, 6.8 and 8.0)

When the close and middle distance areas are considered separately, even close residents with low fear find their general home noise environments are not acceptable (mean of 5.9), but S1 exposures are acceptable and S2 are marginally not acceptable. S3 and S4 exposures are clearly not judged acceptable (means of 6-7.5). The moderate and high fear residents report a similar pattern to the low fear residents, but more emphatically. The S2 mean annoyance for close residents with moderate fear is 6.1, definitely not acceptable.

In contrast, the distant area subjects, with much lower noise level exposures, report different acceptability patterns. The low fear group find their home noise environments acceptable, and stimulus groups S1-S3 acceptable. Only S4 exposures are not acceptable (mean 6.0). The medium and high fear residents, however, report their general environmental noise levels are not acceptable, but S1 and S2 are acceptable. It is of interest that annoyance with exposures of S3 (12 overflights) and S4 (24 overflights) are not acceptable, even at the distant noise levels. These answers also correspond to the reported dissatisfaction with the overall environmental noise conditions, (means of 6.2 for moderate and 8.5 for high fear).

These findings suggest that the numbers and levels of airplane noise exposures that are judged acceptable by the general public will differ with the noise level (distance from airport) and psychological predispositions of the residents. Clearly, 24 exposures and probably even 12 per half hour are too many at even fairly low noise levels. The thresholds of acceptability exposure levels should be determined by further studies of judgements by different distance and fear groups of the many combinations of airplane noise and numbers of operations.

I. Relationships Between 5 and 10-Point Annoyance Scales

In most past studies, an annoyance scale of 0-4 was used to record the relative intensity of annoyance. The limits were defined as "0" meaning "not at all, or none" and "4", "very much". When fairly high noise levels were studied, it was found that the annoyance scores clustered at the top level. Consequently, it was decided to expand the scale to 10-points in the hope that a better distribution of scores would be achieved. An examination of Table 23 indicates that this objective was successful.

To facilitate comparisons of data from older studies with those using the new annoyance scale, a pair of questions was asked in the field interview. After all the different activity-annoyance questions were asked in terms of the 10-point scale, a summary Q.17 was asked, "Now, taking everything into consideration, during the past summer, how bothered or annoyed would you say you were with the airplane noise around here?" (10-point scale used). Then Question 18 was asked, "Now just for this question, instead of the 0-9 item thermometer, (Hand Resp. Card 5) I'd

like you to use this 0-4 number scale, where zero is still "not at all", 4 is "very much" and any number in between expresses the amount of your own feelings. Could you tell me again, just how much the noise from the airplanes this past summer bothered or annoyed you?"

Table 24 presents a cross-tabulation of these parallel questions for the 216 subjects. As can be seen, a fairly consistent pattern of answers is given. To determine the more precise statistical relationships of the two scales, the answers to these two questions were correlated, and the coefficient was a very high $r=.90$. The two regression equations were calculated as follows:

$$Y_1 = .73 + 1.97X$$

$$X_1 = .193 + .414Y$$

In the practical application of these conversion equations, some investigators will want to convert the 10-point scale of one study into a 5-point scale of another study. In other situations, the opposite will be true; conversion will be from a 5-point to a 10-point scale. Since the above two equations may predict different X or Y values depending upon which equations are used, and since there is no reason to assume that either scale should be considered the "independent" values, a new equation was computed where the slope is the square root of the quotient of the two slopes previously calculated, i.e. $\sqrt{\frac{1.97}{.41}}$. The new equations which will produce uniform values are:

$$X_1 = -.08 + .46Y$$

$$Y_1 = .17 + 2.18X$$

<u>X</u>	<u>Predicted</u>	<u>Y</u>	<u>Predicted</u>
0	.17	0	-.08
1	2.35	1	.38
2	4.53	2	.84
3	6.71	3	1.30
4	8.89	4	1.76
		5	2.22
		6	2.68
		7	3.14
		8	3.60
		9	4.06

TABLE 24

CROSS TABULATION OF FIELD REPORTS OF OVERALL ANNOYANCE WITH AIRPLANE NOISE
ON 10 AND 5 POINT SCALES

<u>Annoyance</u> <u>Level</u>	<u>0</u>	<u>1</u>	<u>2</u>	<u>3</u>	<u>4</u>	<u>Total</u>
0	15	2	0	0	0	17
1	0	8	0	0	0	8
2	1	4	2	0	0	7
3	1	8	7	0	0	16
4	0	3	4	1	0	8
5	1	1	21	4	3	30
6	0	2	5	8	2	17
7	0	1	4	9	7	21
8	0	0	0	13	13	26
9	<u>0</u>	<u>0</u>	<u>0</u>	<u>3</u>	<u>63</u>	<u>66</u>
Total	18	29	43	38	88	216

J. Conclusions

About 1300 residents randomly selected from close, middle and distant areas near JFK Airport were interviewed in their homes and reports obtained on airplane noise annoyance and other relevant psycho-social variables. A total of 216 subjects consisting of sub-samples of 72 residents from each of the three distance areas were brought to the Columbia University, Franklin Square, L.I. research laboratory and gave annoyance and acceptability judgements for a mix of aircraft noise exposures comparable to levels heard in their home environments. Subjects judged four different half-hour noise exposures randomly presented. The first consisted of three flights per half hour, and the second included six flights, which was the approximate average number experienced in their homes. The third stimulus included 12 flights, which was the approximate maximum number of "worst day" experiences, and the fourth stimulus included twenty-four overflights per half hour, clearly more than ever experienced by these areas.

Major Findings are:

1. The 216 subjects generally were representative of the residents living in their areas.
2. The integrated aircraft noise annoyance responses obtained from residents on the field interviews are more closely related to laboratory annoyance reports for the maximum number of flights, or "worst day" experiences, rather than to some arithmetic average of varying numbers of flights. The correlation coefficient for all subjects for the "worst day" comparison is $r = .25$, which is significant at the 1% level. When the extreme psychological predisposition groups of subjects represented by their feelings of high and low fear of crashes are excluded, the correlation for all subjects with medium fear attitudes is $r = .34$, and for the separate middle and distant area medium fear groups, the correlation is a high $r = .56$ and $.51$ respectively.
3. There is little doubt that annoyance is generally less when there are fewer aircraft flyovers of comparable noise levels and subjects have favorable predispositions toward airplanes, as reflected in their low fear of aircraft crashes.
4. Beliefs that there are harmful "health effects" due to aircraft noise are also highly correlated with fear of crashes and noise annoyance. The "health effects" generally mentioned are; creates tension, harms hearing, disturbs sleep and communication and adds to fear.
5. Subjects found it difficult to compare directly their laboratory and home environment noise exposures. Nevertheless, the "worst day" laboratory stimulus was most closely related to the retrospective judgements of the home environment. A plurality of 39% said that the "worst day" laboratory exposure had the same number of flights as their usual home exposure. Almost half said the "worst day" laboratory exposure was equally noisy and equally annoying as their home experiences.
6. Subjects defined the 10-point annoyance scale as follows: 0-2 acceptable by practically all, scores of 3-4 acceptable by 80%, 5-6 acceptable by 50-60%, scores of 7 acceptable by only 28% and 8-9 annoyance scores acceptable by about only 5% of all subjects.
7. Annoyance and acceptability judgements vary by how fearful of crashes and how close a resident lives to the airport. The highest fear group living closest to the airport and experiencing the most intense noise exposures, reports the most

fear and least acceptability. How much protection for how many people is clearly a political and administrative decision but, if for illustrative purposes, the median annoyance-acceptability scores of 5-6 are assumed to be the goals for administrative noise control, then even the close residents with low fear and favorable psychological predispositions report their home annoyance levels are not acceptable. In contrast, the low fear group living in the distant areas find the annoyance in their homes and most laboratory exposures acceptable. The medium fear group from all distances, which represents a modal population, reports their home environment and their "worst day" exposures are clearly not acceptable.

8. A conversion equation was developed for the new 10-point scale of annoyance and previously used 5-point scales. The correlation of these two scales is a very high $r = .90$.

BIBLIOGRAPHY

- 1/ Borsky, Paul N., Community Aspects of Aircraft Noise - National Advisory Committee for Aeronautics, 1952.
- 2/ Borsky, Paul N., Community Reactions to Air Force Noise, W.A.D.D., Technical Report 60-689, March 1961.
- 3/ Borsky, Paul N. - Leonard, Skipton - A Causal Model for Relating Noise Exposure, Psycho-social Variables and Aircraft Noise Annoyance, International Congress on Noise as a Public Health Problem, Dubrovnik, Yugoslavia, May 13-18, 1973.
- 4/ McKennell, A.C., Aircraft Noise Annoyance Around London Airport, Central Office of Information, London 1963.
- 5/ Heathrow Airport Survey, Mil Research Ltd., London 1967.
- 6/ Carlsson, Gosta, Ronge, Hous., Attitude and Opinion Studies on Human Reactions to Aircraft Noise, University of Lund, Sweden, April 1962.
- 7/ Grandjean, Etienne et al, A Survey of Aircraft Noise in Switzerland, Proceedings "International Congress on Noise as a Public Health Problem", Dubrovnik 1973
- 8/ Annoyance Caused by Noise Around Airports - Center Scientifique et Technique du Batiment, Paris, March 1, 1968.
- 9/ Finke, H. O., Guski H., Bohrman B., et al. An Interdisciplinary Study of the Effects of Aircraft Noise on Man, Proceedings "International Congress on Noise as a Public Health Problem", Dubrovnik 1973.
- 10/ Borsky, Paul N., A New Field-Laboratory Methodology for Assessing Human Response to Noise, NASA Report CR-2221, March 1973.
- 11/ Borsky, Paul N. - Leonard, Skipton - Annoyance Judgements of Aircraft With and Without Acoustically Treated Nacelles, NASA Report CR-2261, August 1973.
- 12/ Borsky, Paul N., Annoyance and Acceptability Judgements of Noise Produced by Three Types of Aircraft by Residents Living near JFK Airport, Columbia University Report, December 1974.
- 13/ Society of Automotive Engineers, Proposal AIR 1087.
- 14/ Nunnally, J. - Psychometric Theory, McGraw Hill, New York 1967.
- 15/ Borsky, Paul N. - Special Analyses of Community Annoyance with Aircraft Noise Reported by Residents in the Vicinity of JFK Airport-1972 - Columbia University Report, September 1975
- 16/ Hovland, Carl I., Reconciling Conflicting Results Derived from Experimental and Survey Studies of Attitude Change, The American Psychologist, Volume 14, January 1959.

- 17/ Hicks, C. R. - Fundamental Concepts in the Design of Experiments, Holt, Rinhart and Winston 1973.
- 18/ U.S. Environmental Protection Agency - Information on Levels of Environmental Noise Requisite to Protect Public Health and Welfare with an Adequate Margin of Safety, Report 550/9-74-004, Washington, D.C., March 1974.