

NASA Technical Memorandum 101459

A Comparison of Reflector Antenna Designs for Wide-Angle Scanning

(NASA-TM-101459) A COMPARISON OF REFLECTOR
ANTENNA DESIGNS FOR WIDE-ANGLE SCANNING
(Illinois Univ.) 30 P CSCL 20N

N89-21138

G3/32 Unclass
0191962

M. Zimmerman, S.W. Lee,
and B. Houshmand
*University of Illinois at Urbana-Champaign
Urbana, Illinois*

Y. Rahmat-Samii
*Jet Propulsion Laboratory
Pasadena, California*

and

R. Acosta
*Lewis Research Center
Cleveland, Ohio*

February 1989

NASA

A COMPARISON OF REFLECTOR ANTENNA DESIGNS FOR WIDE-ANGLE SCANNING*

M. Zimmerman, S.W. Lee, and B. Houshmand

University of Illinois at Urbana-Champaign, Urbana, Illinois 61801

Y. Rahmat-Samii

Jet Propulsion Laboratory, Pasadena, California 91109

R. Acosta

NASA Lewis Research Center, Cleveland, Ohio 44135

Abstract

Conventional reflector antennas are typically designed for up to ± 20 beamwidths scan. In this paper we try to stretch this scan range to some ± 300 beamwidths. We compare six single and dual reflector antennas. It is found that a symmetrical parabolic reflector with $f/D=2$ and a single circular waveguide feed has the minimum scan loss (only 0.6 dB at $\theta_0=8^\circ$, or a 114 beamwidths scan). The scan is achieved by tilting the parabolic reflector by an angle equal to the half-scan angle. The f/D may be shortened if a cluster of 7 to 19 elements instead of one element is used for the feed. The cluster excitation is adjusted for each new beam scan direction to compensate for the imperfect field distribution over the reflector aperture. The antenna can be folded into a Cassegrain configuration except that, due to spillover and blockage considerations, the amount of folding achievable is small.

*Portions of this material were presented at the NASA Technology Workshop for Earth Science Geostationary Platforms, September 21-22, 1988 at NASA Langley Research Center, Hampton, Virginia.

I. Introduction

Traditionally, reflector antennas are designed for limited scan. A symmetrical parabolic reflector with $f/D=0.4$ can only scan ± 5 beamwidths (BW) with less than 2 dB loss [1]. If the reflector diameter is $1,000 \lambda$, the ± 5 BW scan corresponds to only $\pm 0.5^\circ$, which is a very narrow field of view.

In some future applications, the antenna requirements will be quite different from what they presently are. One example is the NASA Earth Science Geostationary Platform Project. The preliminary antenna specifications are as follows:

Frequency range	20 GHz - 200 GHz
Antenna diameter	15 m ($1,000 \lambda$ - $10,000 \lambda$)
Scan range 1	$\pm 2^\circ$ (± 33 BW - ± 330 BW)
Scan range 2	$\pm 8^\circ$ (± 133 BW - $\pm 1,333$ BW)

Note that the scan requirement has been significantly increased from the traditional value of ± 5 BW. Usually a phased array design is used to satisfy specifications such as these.

A phased array antenna design is an order of magnitude more complicated than a reflector design. This is due to the large number of array elements and the beam-forming network contained in the design. Reflector antennas have the additional advantage of being less expensive and lighter in weight than phased arrays. Therefore it is desirable to use a reflector antenna design if at all possible. The question then is can a reflector antenna be designed that is capable of meeting these specifications?

This paper examines and compares six different reflector designs. We intend to show how far the reflector performance can be stretched. The object is to achieve a wide-angle scan that will satisfy requirements such as those listed above. The first three designs, P1, P2, and P3, are parabolic single reflector designs. These three designs are considered in Section II. The first design is a center-fed, single-element feed design with $f/D=2$ (Fig. 1a). Scanning is accomplished by mechanically tilting the reflector. The second design has

$f/D=1$ and uses a 19 element cluster feed but otherwise is similar to the first design (Fig. 1b). The third design is an off-set reflector with $f/D=2$ and an electronically scanned cluster feed (Fig. 1c).

The last three designs, C1, C2, and C3, are dual reflector Cassegrain designs. They are considered in Section III. The three designs all use the same reflector geometry. The first design scans by mechanically tilting the main reflector (Fig. 2a). The second design scans by mechanically tilting the subreflector (Fig. 2b). The last design scans by tilting both the main reflector and the subreflector (Fig. 2c).

Data on extremely wide-angle scans of reflector antennas are scarce in the literature. Hung and Mittra [2] in 1986 did analyze a center-fed symmetrical parabolic reflector with a cluster feed, and calculate patterns up to a hundred beamwidth scan. We have verified our single reflector computer code by comparing with their results.

II. Single Reflector Antennas

P1: Symmetric Parabolic Reflector with $f/D=2$

Two contributing factors to poor scanning ability are (i) short focal length and (ii) high off-set. For these reasons, the first design considered is a symmetrical parabolic reflector with an unusually long focal length. Design P1 has a diameter $D=1,000 \lambda$ and a focal length $f=2,000 \lambda$, thus giving $f/D=2$. The feed is a long circular open-ended waveguide with radius $a=3 \lambda$. A study was done of the directivities and beam efficiencies corresponding to various feed radii. The results are shown in Figure 3, with directivities converted to antenna efficiency. Antenna efficiency is defined as the fraction of the nominal directivity that the given directivity is, namely,

$$\eta_{ant}=(\text{Directivity})/(\pi D/\lambda)^2. \quad (1)$$

In this case, the nominal directivity $(\pi D/\lambda)^2$ is 69.9 dB. The radius value chosen was that which maximized beam efficiency. The antenna has a half-power beamwidth $HPBW=0.07^\circ$. Beam efficiency is calculated as the fraction of power hitting the reflector that is contained in the beam defined as being 2.5 times as large as the HPBW. In this case, the beam has a half angle of approximately 0.09° . Note that this definition of beam efficiency does not take into account spillover loss. The chosen radius value of 3λ produces the highest beam efficiency, $\eta=0.91$. Scanning is accomplished by tilting the main reflector. Tilting the main reflector by α degrees results in a scan angle $\theta \approx 2\alpha$. The main advantage of tilting the reflector instead of moving the feed element is that the scan angle is twice the angle of tilt. If the feed were moved then the angle of scan would be equal to the angle that the feed was moved through. This is referred to as the mirror effect. Since for any reflector design, the scan loss increases as the feed moves away from the reflector's focal point, a significant reduction in scan loss is gained by tilting the reflector instead of shifting the feed.

Features of reflector P1 are:

1. Virtually no feed blockage due to the small size of the single element feed.
2. Depending on the exact arrangement, there is a lossy transmission distance between the feed and the receiver/transmitter. To avoid excessive transmission loss at high frequency applications (60 GHz or more), it may be necessary to connect the feed and the receiver/transmitter via a beam waveguide.
3. Because of the mirror effect, the scan range is twice as far as the conventional shifted feed design.

The radiation pattern for the on-axis beam is shown in Figure 5. The radiation pattern is calculated by a standard physical optics reflector code [3]. The directivity is 66.7 dB which includes the following losses:

Nominal directivity $(\pi D/\lambda)^2$		69.9 dB
Feed spillover loss	-	0.6 dB
Amplitude taper over reflector surface	-	<u>2.6 dB</u>
Directivity		66.7 dB

The above directivity, as usual, does not include the loss due to the feed transmission line. The 3λ radius feed produces a pattern that has a null before the edge of the reflector (Fig. 4). This pattern results in a sidelobe level of -31 dB. It is a commonly used rule-of-thumb that to maximize beam efficiency, the first feed pattern null should lie on the reflector edge, which is at $\theta_{\max}=14.25^\circ$. The first null lay on the reflector edge for feed radius $a=2.3\lambda$. This value produces close to a maximum in beam efficiency (see Fig.1).

This reflector has extremely good scan characteristics because of the long f/D and the mirror effect. The scan loss is only 0.6 dB at $\theta_0=8^\circ$ (Fig. 6), corresponding to a 114 beamwidth scan. The sidelobe level does increase from -31 dB to -13 dB as expected. At

a larger scan angle $\theta_0=20^\circ$ (286 beamwidth scan), the scan loss is 5.1 dB and the pattern is badly distorted with a high shoulder (Fig. 7).

P2: Symmetric Parabolic Reflector with $f/D=1$

A drawback of P1 is its excessively long focal length ($2,000 \lambda$). Now let us reduce it by one half, giving a $f/D=1$. Then wide-angle scan is possible only if a cluster feed is used. A brief explanation of the cluster feed concept is in order at this point. The feed cluster consists of N identical elements with complex excitations

$$\mathbf{I}=[I_1, I_2, \dots, I_N] \quad (2)$$

We wish to determine \mathbf{I} so that, when the beam position is at θ_0 , a prescribed antenna parameter such as directivity, beam efficiency, or sidelobe level is optimized. To this end, let us introduce an element secondary pattern vector \mathbf{E} such that

$$\mathbf{E}(\theta_0)=[E_1(\theta_0), E_2(\theta_0), \dots, E_N(\theta_0)] \quad (3)$$

where $E_2(\theta_0)$, for example, is the co-polarization secondary pattern in direction θ_0 when element 2 is excited with

$$\begin{cases} I_2 = 1 \\ I_m = 0 \end{cases}, \text{ for all } m \neq 2 \quad (4)$$

There exist three methods for determining \mathbf{I} in literature.

- (i) Conjugate Field Matching [4-11]. The cluster excitation is simply set equal to the complex conjugate of $\mathbf{E}(\theta_0)$, i.e.,

$$\mathbf{I}=[\mathbf{E}(\theta_0)]^* \quad (5)$$

Strictly speaking, such a choice of cluster excitation does not optimize any particular antenna parameter. For practical purposes, however, it does lead to nearly optimum directivity in most cases.

- (ii) Optimum Directivity [12]. For a feed cluster with prescribed primary patterns and element locations, the directivity in direction θ_0 is optimized by choosing

$$\mathbf{I} = \bar{\bar{\mathbf{A}}}^{-1} [\vec{\mathbf{E}}(\theta_0)]^* \quad (6)$$

where $\bar{\bar{\mathbf{A}}}$ is a $N \times N$ square matrix with elements

$$A_{mn} = \frac{1}{C} \int_0^{4\pi} (E_m E_n) d\Omega \quad (7)$$

where C is a normalization constant, and the integration is over 4π - radiation sphere. When the element spacing of the cluster is large (a few wavelengths), matrix $\bar{\bar{\mathbf{A}}}$ is nearly an identity matrix. Then the solution in (6) reduces to that in (5).

- (iii) Sidelobe Control [13,14]. The element secondary pattern vector \mathbf{E} in (3) is normally calculated in a transmitting approach. By reciprocity, it can be equally calculated in a receiving approach when the reflector is illuminated by an incident plane wave from direction θ_0 . In the receiving approach, there is an additional advantage that the amplitude of the plane wave can be tapered. It is found that the amount of taper controls the sidelobe level of the final secondary pattern when the whole cluster is turned on.

Return now to P2 in Figure 1. A 19-element cluster feed is used. The individual elements are circular feeds with radius $a=1.2 \lambda$. This value is chosen to maximize directivity for a single feed scanned on-axis. This radius feed also produces a relatively good beam efficiency with $\eta=0.88$. The maximum beam efficiency was $\eta=0.89$, which is recorded for a feed with radius $a=1.3 \lambda$. Sidelobes for the $a=1.2 \lambda$ feed were -23 dB. This was not nearly the best possible sidelobes value, as a feed with radius $a=1.5 \lambda$ had sidelobes that were -32 dB, along with $\eta=0.87$. The primary pattern of the $a=1.2 \lambda$ circular waveguide feed was approximated by a $\cos^q \theta$ pattern with $q=9.5$. This value of q

gave good sidelobe matching but the main lobe was 0.6 dB higher, with a maximum directivity of 68.9 dB. Spillover loss for the $\cos^4\theta$ feed pattern was 0.4 dB for $a=1.2 \lambda$. The cluster feed is used to help compensate for the higher scan losses that result from the lower f/D . At small scan angles only the center feed element has a relatively strong excitation (Fig. 8a). For an 8° scan (i.e. the reflector is tilted 4°) only two of the outer ring elements have significant excitations (Fig. 8b). This indicates that for scans under 8° , a 7-element cluster feed would probably work almost as well as a 19-element feed. When the reflector is tilted 10° for a scan angle of 20° , nearly all of the elements are excited (Fig. 8c). At $\theta_0=8^\circ$, the scan loss is 3.7 dB (Fig. 9, 10) and at $\theta_0=20^\circ$, the scan loss is 7.4 dB (Fig. 11). Very similar scan loss results were obtained with $a=1.5 \lambda$ feed. This is not as good as the results for P1, but it is only a few dB worse. The advantage of P2 over P1 is that the focal length has been cut in half. The disadvantage is that a 19 element feed is much more complicated than a single element feed. For both of these center-fed designs the feed blockage is negligible.

Though design P2 has a higher scan loss at $\theta_0=20^\circ$ than P1, the beam is less distorted (see Fig.7 and Fig.11). This is because at scan angles of this size, the cluster feed is able to form a much better beam pattern than a single element feed. For angles below $\theta_0=8^\circ$, there is no benefit to design P1 from using a cluster feed. However, scan loss could be reduced for large scan angles by using a cluster feed.

P3: Off-set Parabolic Reflector

Design P3 is an off-set parabolic reflector. Off-set height must be kept as small as possible to avoid intolerably high scan loss. Unfortunately, small offset leads to serious feed blockage. A possible way out of this dilemma is to use two identical reflector antennas: one for scanning up and one for scanning down as sketched in Fig. 1. The focal length is $2,000 \lambda$ and the reflector diameter is $1,000 \lambda$, for a $f/D=2$. The off-set height is zero. In contrast to P1 and P2, this design utilizes electronic scanning. This means that a large feed

array is used. Up to 19 elements are excited at any time. In order to cover a scan range from $\theta_0=0^\circ$ to $\theta_0=8^\circ$, a semicircular array with a radius of 283λ must be used. The individual feed elements have a radius $a=1.065 \lambda$, meaning that roughly 0.13 million feeds elements are needed for the entire device. This feed size is chosen so that if the excited element is turned off and an adjacent element is turned on, then the beam is scanned 1 BW. This antenna has a on-axis directivity of 66.2 dB when a single element is turned on. The spillover loss is 3.5 dB. This is quite high since the feed element is so small. Note that this antenna has roughly the same $\theta_{\max}=14.3^\circ$ as P1, which uses a feed that is three times larger in radius.

The advantage of electronic scan is well-known: it is fast and inertialess. However, electronic scanning forces the use of a feed array that has half the diameter of one of the reflectors used. Therefore this design uses about a fourth as many elements as a phased array with the same aperture size. The savings in complexity are almost lost. In addition the overall volume occupied by this antenna is much larger than that needed by the previous designs. For the on-axis beam, only the center element of the 19 element cluster is significantly excited (Fig. 12,13), with a directivity of 67.3 dB. This is slightly higher than that excited by a single element feed (66.2 dB). Although excited with small excitations, the surrounding elements do help to reduce the spillover (Fig. 15).

Another problem is that the design puts a physical limitation on the maximum scanning angle. This is because the feed elements don't move. The previous designs could have been scanned farther than 20° if it had been desired. This design has a directivity of 67.3 dB, with $BW=0.06^\circ$ and sidelobes at -18 dB. Patterns were computed at scan angles $\theta_0=0^\circ$ and $\theta_0=8^\circ$. The feed excitations used to get these results are shown in Figure 12. At $\theta_0=8^\circ$, scan loss is already 6.3 dB (Fig. 13,14). The advantages of electronic scanning are that it is quicker than mechanical scanning and that it will not upset the equilibrium of the spacecraft since there is no physical motion. Some of the drawbacks listed above could be avoided by mechanically moving a 19 element feed cluster instead of

electronically scanning. However, this design has much more scan loss at $\theta_0=8^\circ$ than designs P1 and P2.

III. Dual Reflector Antennas

C1: Cassegrain Reflector with Tilted Main Reflector

Design C1 is dual-reflector Cassegrain antenna. The main reflector is parabolic with a focal length of $2,000 \lambda$ and a diameter of $1,000 \lambda$ for a $f/D=2$. A Cassegrain antenna may be considered as a folded version of a parabolic reflector. In many applications, it is desirable to reduce the length of the antenna and to place the feed directly behind the vertex of the main reflector. These are the reasons for folding the antenna. With $f/D=2$ for the present case, it is not possible to fold the feed close to the vertex without either excessive spillover loss or an excessively large subreflector or even both. In the present design (Fig. 2), the hyperbolic subreflector has a diameter of 115λ and is located $1,650 \lambda$ from the the main reflector vertex. The circular feed has a radius $a=1.5 \lambda$ and is located $1,300 \lambda$ from the main reflector vertex. This feed size is chosen to produce 10 dB edge taper on the subreflector. Directivity for this design is 67.1 dB, with $BW=0.06^\circ$ and a -18 dB sidelobe level. Scanning is accomplished by tilting the main reflector. The scan angle $\theta_0=2\alpha_1$, where α_1 is the angle that the main reflector is tilted. There is a discontinuity in the scan loss at about $\theta = 14^\circ$, the point where the main reflector is tilted so far that some of the energy from the subreflector begins to miss the main reflector. The performance of C1, shown in Figures 15 and 16, is similar to that of P1, the unfolded version of C1. The use of the subreflector does change the aperture taper. Consequently, the sidelobes of C1 and P1 are different.

C2: Cassegrain Reflector with Tilted Subreflector

Design C2 has the same geometry as C1. Scanning is accomplished by tilting the subreflector instead of the main reflector. Due to the substantial difference in size, tilting the subreflector is much easier mechanically than tilting the main reflector. Electrically, however, tilting the subreflector for wide-angle scan is not feasible because

- (i) The subreflector must be tilted by a much larger angle α_2 in order for the beam to scan. The approximate relation between the two angles is

$$\theta_0 \approx \alpha_2 / M$$

where $M = D_{\text{main}} / D_{\text{sub}} =$ magnification factor.

- (ii) When the subreflector is tilted by a large angle, there is an excessive spillover loss.

In this case $M=8.7$. The scan loss is quite high. At $\theta_0=1.75^\circ$, the scan loss is 6.6 dB (Fig. 18). At $\theta_0=3.32^\circ$, the scan loss is 36.3 dB. This would seem to indicate that tilting the subreflector is not a viable option for wide-angle scan.

C3: Cassegrain Reflector with Both Reflectors Tilted

Design C3 has the same geometry as C1 and C2. Scanning is accomplished by tilting both the subreflector and the main reflector. The idea is to use the main reflector for coarse scanning, and to use subreflector tilting for local scanning within a small angular region. The scan angle $\theta_0 \approx 2(\alpha_1 + \alpha_2 / M)$. Given α_1 and α_2 , the scan loss can be obtained by looking at the results for C1 and C2.

IV. Conclusions

We have studied the wide-angle scan ability of the six reflector antennas shown in Figures 1 and 2. All reflectors have a circular diameter of $1,000 \lambda$ and $f/D=2$, except that P2 has a shorter focal length $f/D=1$. The scan loss is summarized in Figure 19.

Conclusions are listed below.

- (i) For mechanical scan by tilting reflectors, the best system is P1. The scan loss at $\theta_0=8^\circ$ (114 beamwidth) is only 0.6 dB (Fig. 5,6). The sidelobe level for the $\theta_0=8^\circ$ position is increased considerably (from -31 dB to -13 dB). This problem may be alleviated by using the cluster compensation method [10,12,14], and needs to be studied.
- (ii) The folded version of P1 is the Cassegrain antenna C1. In the present study, the feed is taken to be a single open-ended circular waveguide with $a=3 \lambda$. As a consequence, the amount of folding achieved is small (the length reduction is from $2,000 \lambda$ to $1,650 \lambda$). If more folding is desired, a much larger feed should be used.
- (iii) To shorten the f/D from 2 to 1, reflector P2 must rely on a cluster feed to reduce its scan loss. The excitation of the cluster varies as the beam scans. The scan performance of P2 is still not as good as that of P1, indicating that a 19-element cluster cannot totally compensate the reduction in f/D .
- (iv) Tilting the subreflector of a Cassegrain antenna can only achieve a small scan (about ± 15 BW). It can be used in conjunction with the electrically more effective but mechanically more costly main reflector tilting to achieve a small local scan.
- (v) Among the six antennas, only the off-set parabolic reflector P3 scans the beam electronically. The price is steep since (a) there are two identical antennas, one to scan up and one to scan down, (b) the feed has 0.13 million elements, and

(c) with a 19-element feed cluster, the scan loss at $\theta_0=8^\circ$ is 6.3 dB. Without the cluster, the loss is 15.4 dB. This is much worse than the 0.6 dB loss for P1.

REFERENCES

- [1] Y. Rahmat-Samii: Reflector Antennas. Antenna Handbook, ed. Y. T. Lo and S. W. Lee, Van Nostrand Reinhold, p. 15-61, 1988.
- [2] C. C. Hung and R. Mittra, "Wide-angle scanning for reflector antennas," *URSI Sym. Digest*, p.75, May 1983.
- [3] P. T. Lam, S. W. Lee, C. C. Hung, and R. Acosta, "Strategy for reflector pattern calculation: let the computer do the work," *IEEE Trans. Antennas & Propagation*, vol. 34, pp. 592,594, 1986.
- [4] H. C. Minnett and B. MacA. Thomas, "Fields in the image space of symmetrical focusing reflectors," *Proc. IEEE*, vol. 115, pp. 1419-1430, 1968.
- [5] A. W. Rudge and M. J. Withers, "Design of flared-horn primary feeds for parabolic reflector antennas," *Proc. IEEE*, vol. 117, pp. 1741-1749, 1970.
- [6] H. H. S. Luh, "On the radiation pattern of a multibeam antenna," *IEEE Trans. Antennas & Propagation*, vol. AP-24, pp. 101-102, 1976.
- [7] Y. Rahmat-Samii and S. W. Lee, "Applications of the conjugate field matching technique to reflector antennas--a critical review," *URSI Digest*, p. 85, 1981.
- [8] A. V. Mrstik and P. G. Smith, "Scanning capabilities of large parabolic cylinder reflector antennas with phased-array feeds," *IEEE Trans. Antennas & Propagation*, vol. AP-31, pp.756-763, 1983.
- [9] C. C. Hung and R. Mittra, "Secondary pattern and focal region distribution of reflector antennas under wide-angle scanning," *AP Digest*, vol. AP-31, pp. 463-470, May 1983.
- [10] H. Y. Jong, B. Popovich, W. R. Adams, and A. W. Love, "Analysis of paraboloidal reflector fields under oblique incidence," *AP Digest*, vol. 1, pp. 305-308, 1984.
- [11] R. J. Acosta, "compensation of reflector surface distortion using conjugate field matching," *AP-S International Symp. Digest*, vol. 1, pp. 259-262, 1986.
- [12] P. T. Lam, S. W. Lee, D. C. D. Chang, and K. C. Lang, "Directivity optimization of a reflector antenna with cluster feeds: A closed form solution," *IEEE Trans. Antennas & Propagation*, vol. AP-33, pp.1163-1174, 1985.
- [13] R. Acosta, A. Zaman, E. Bobinsky, A. R. Cherrette, and S. W. Lee, "Case study of active array feed compensation with sidelobe control for reflector surface distortion," *AP-S International Symp. Digest*, vol. 2, pp. 863-867, 1988.
- [14] R. Acosta, "Active feed array compensation for reflector antenna surface distortion," NASA TM100826, NASA Lewis Research Center, Cleveland, OH 44135, June 1988.

A. P1: Tilting Parabolic Reflector

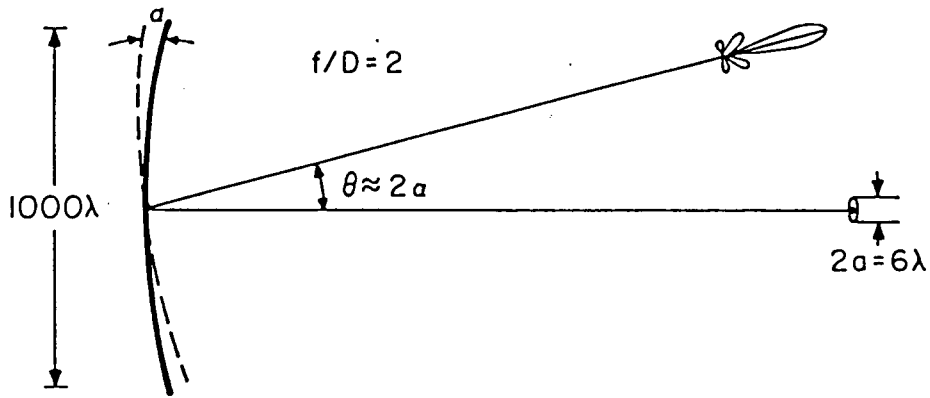

B. P2: Same as P1 Except $f/D=1$ and Cluster Feed

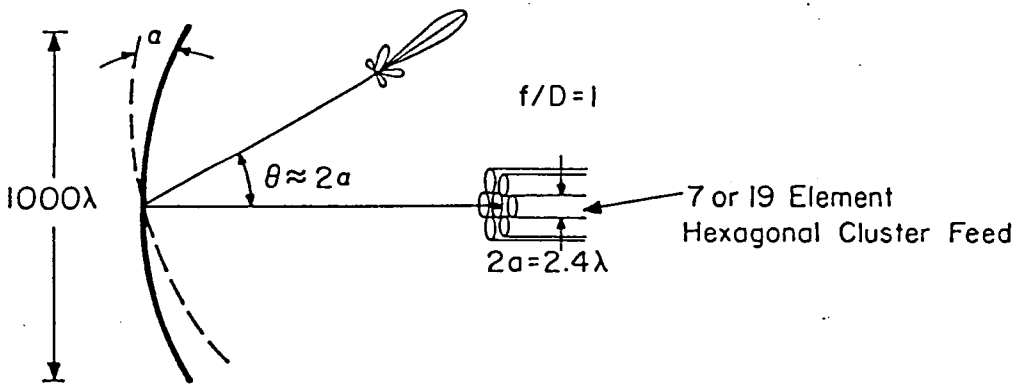

C. P3: Off-set Parabolic Reflector With Electronic Scan

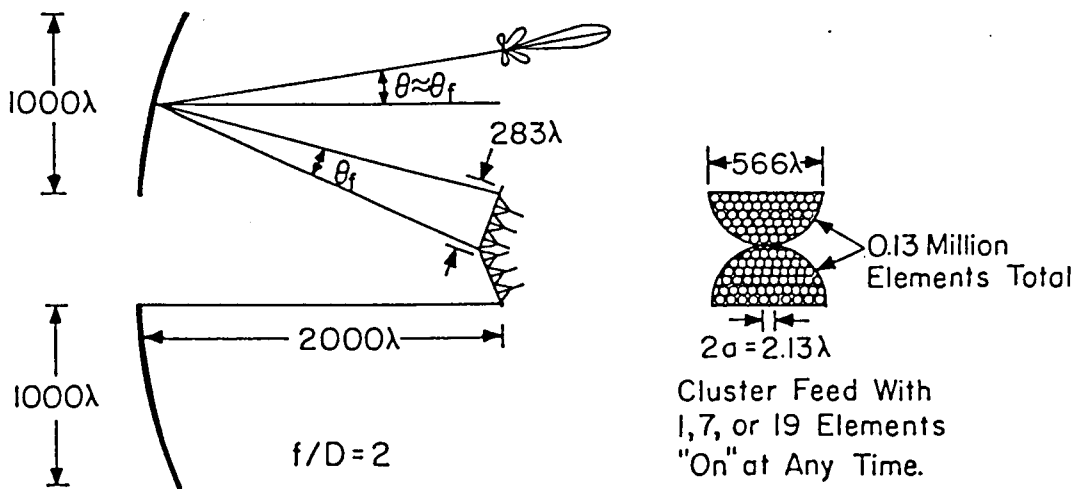
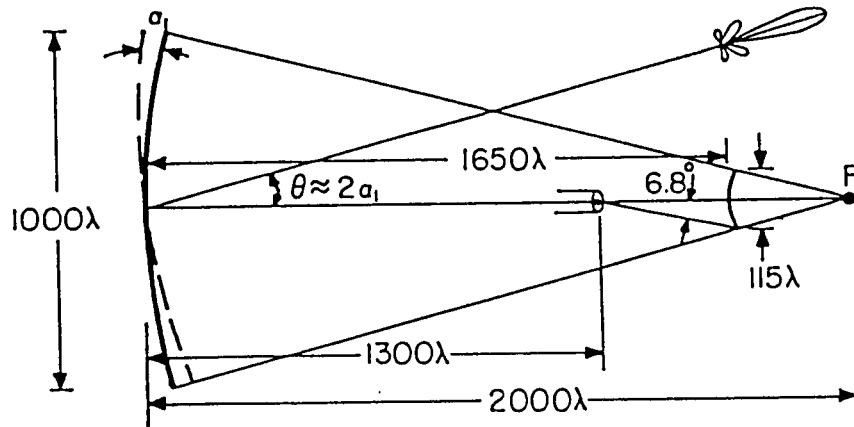
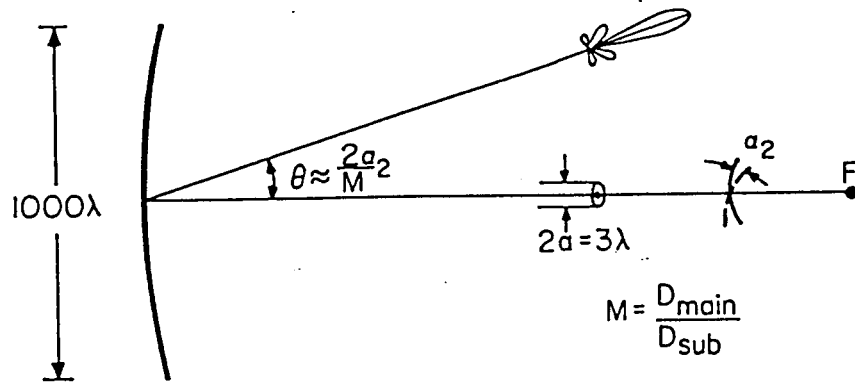

Figure 1. Single Reflector Antenna System

A. C1: Tilting Main Reflector



B. C2: Tilting Subreflector



C. C3: Tilting Both Reflectors

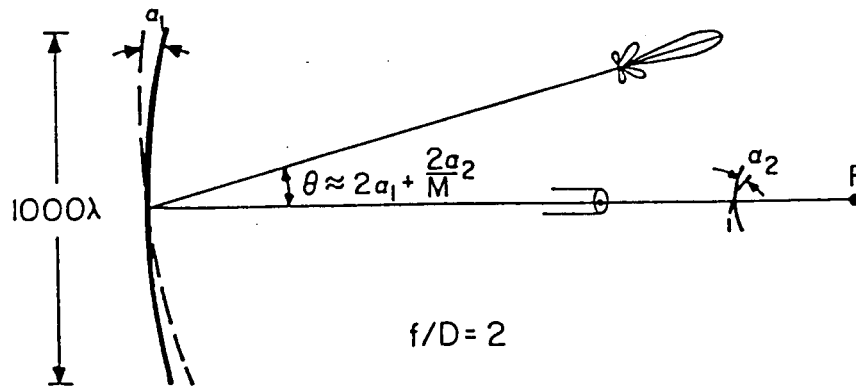

Figure 2. Cassegrain Dual Reflector Antenna Systems

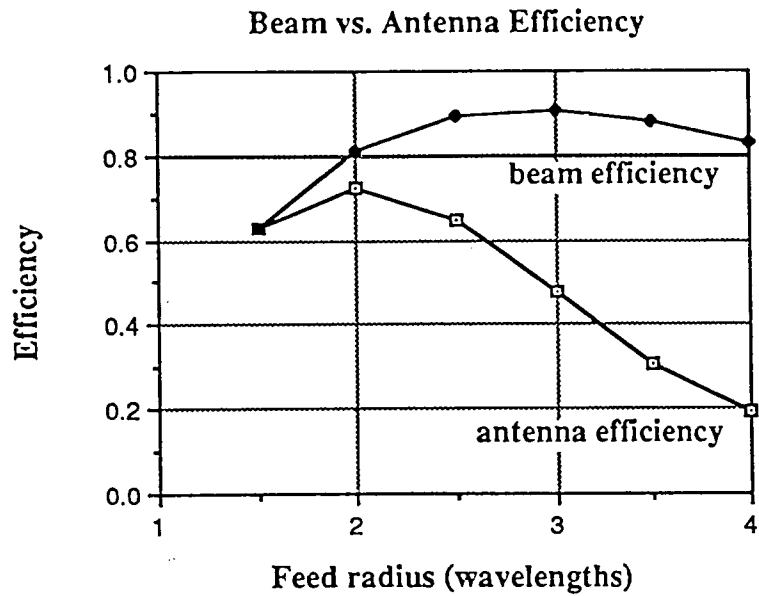

Figure 3. Beam efficiency and antenna efficiency for P1 symmetrical parabolic reflector as a function of feed radius. The feed is an open-ended circular waveguide.

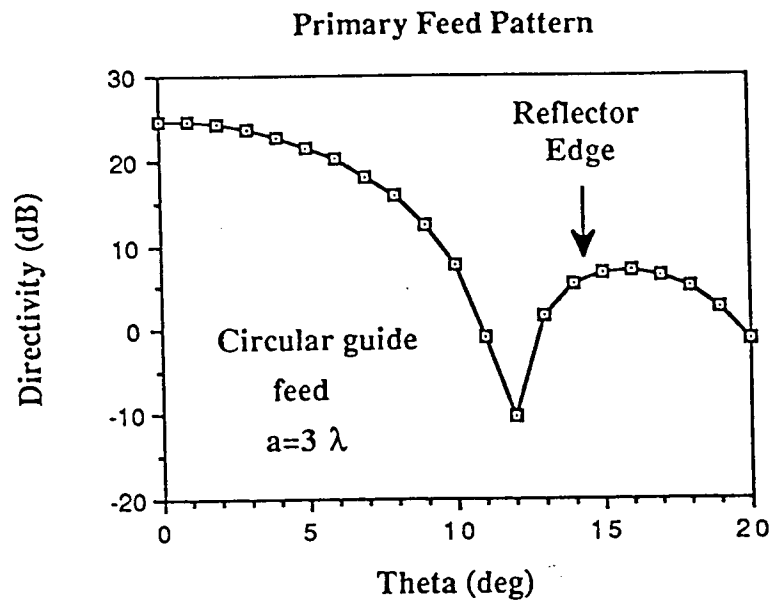

Figure 4. Primary feed pattern for P1 symmetrical parabolic reflector. The feed is an open-ended circular waveguide.

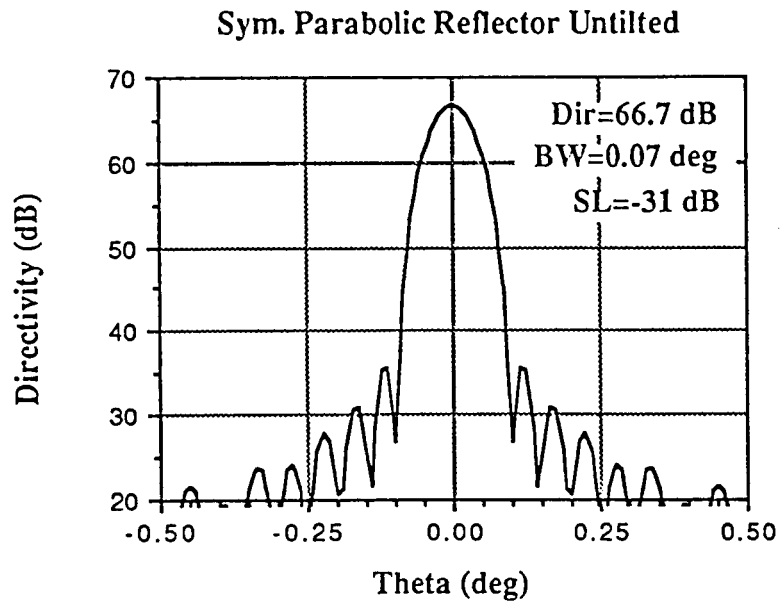

Figure 5. P1 symmetric parabolic reflector far-field pattern for 0° scan.

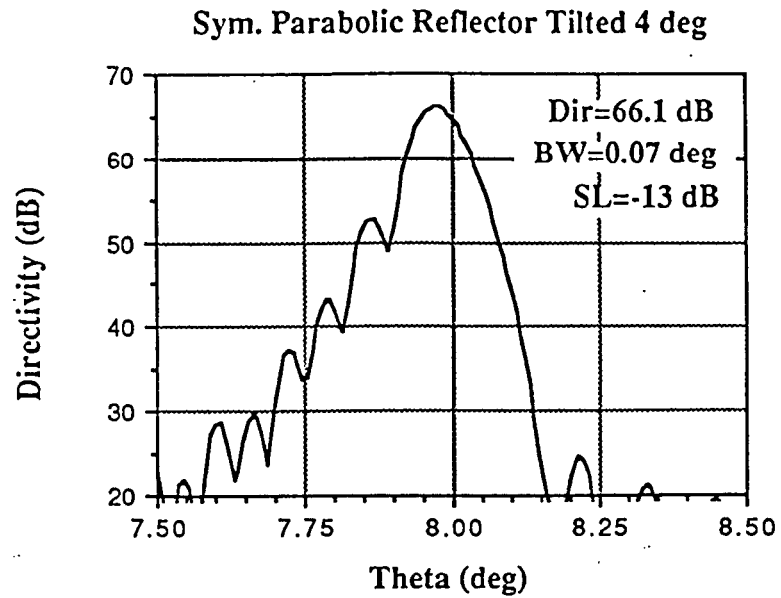

Figure 6. P1 symmetrical parabolic reflector far-field pattern for 8° scan (114 beamwidth scan).

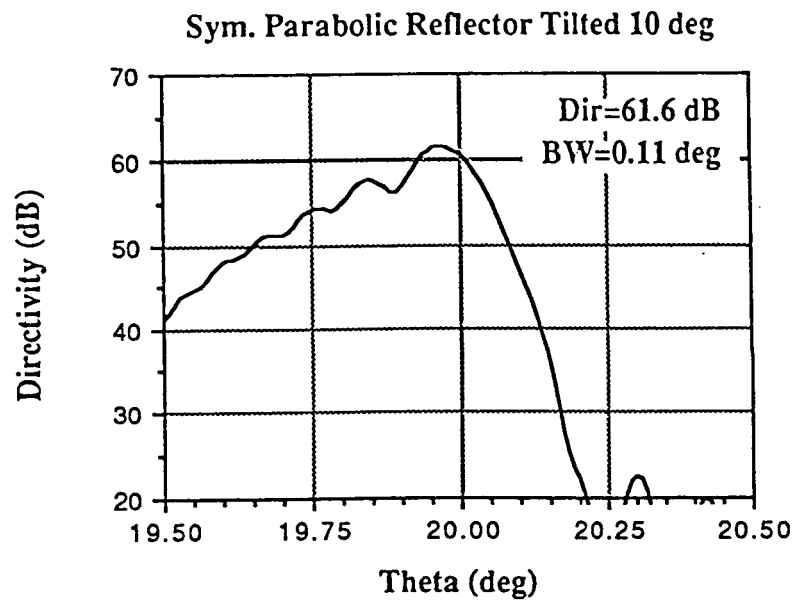

Figure 7. P1 symmetrical parabolic reflector far-field pattern for 20° scan (286 beamwidth scan).

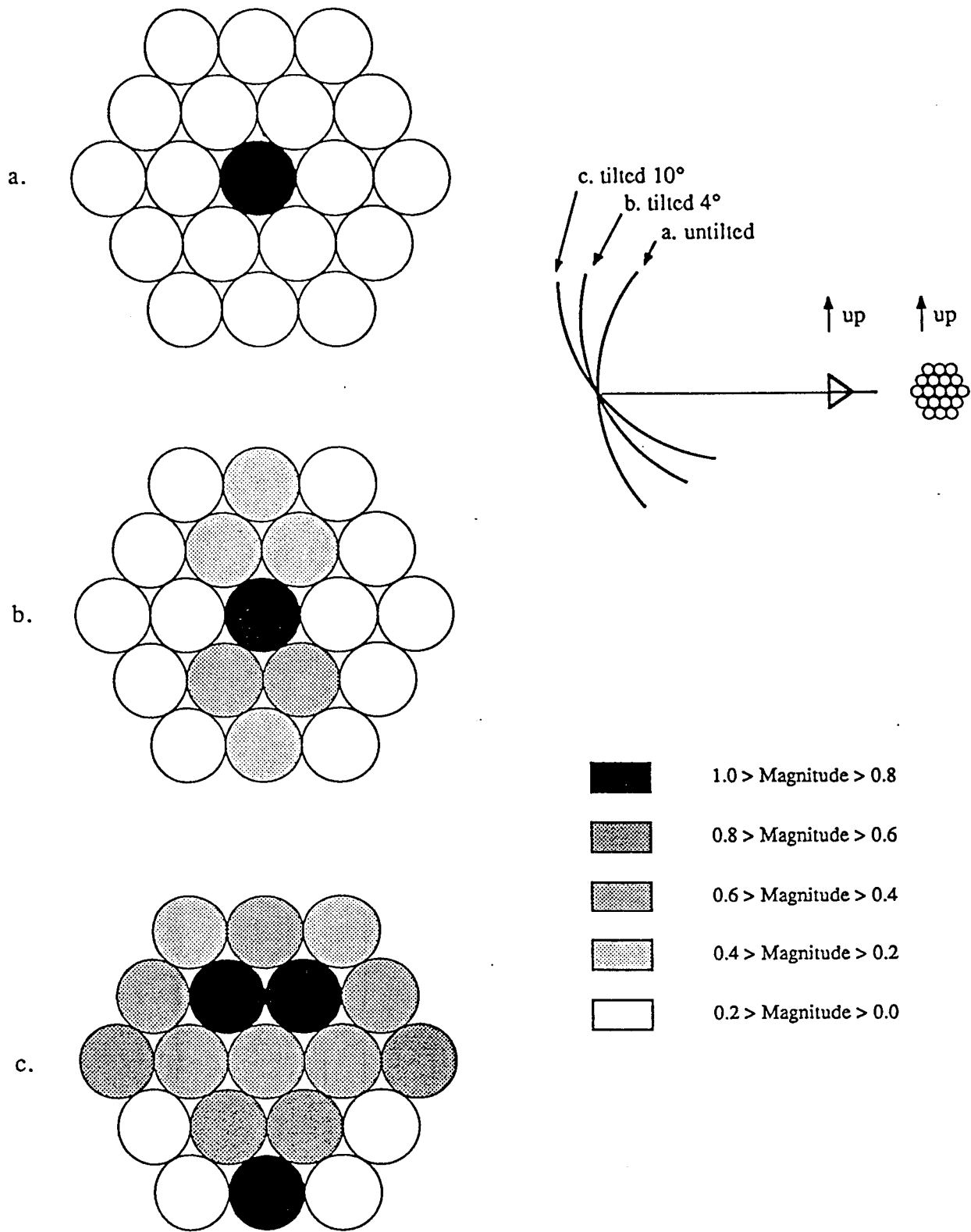

Figure 8. Relative excitations for the 19-element feed cluster in P2 symmetrical parabolic reflector: (a) beam scanned 0° , (b) beam scanned 8° , and (c) beam scanned 20° .

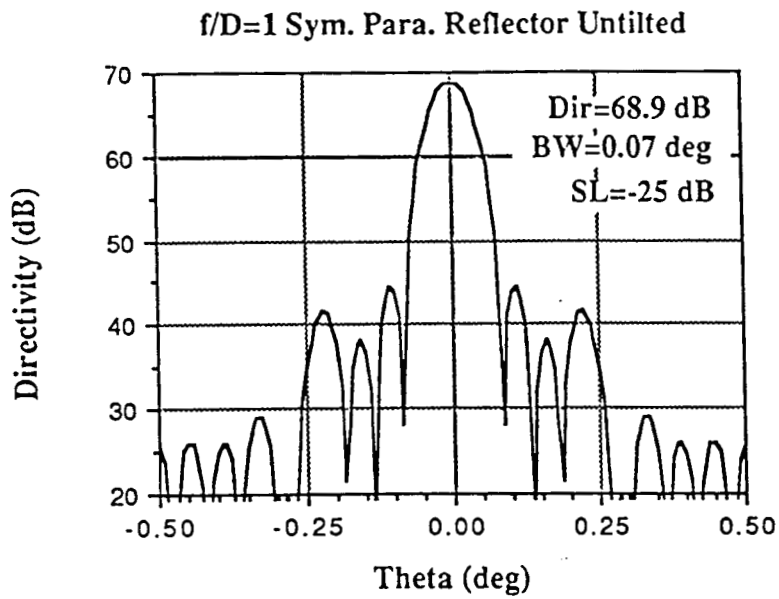

Figure 9. P2 symmetric parabolic reflector far-field pattern for 0° scan.

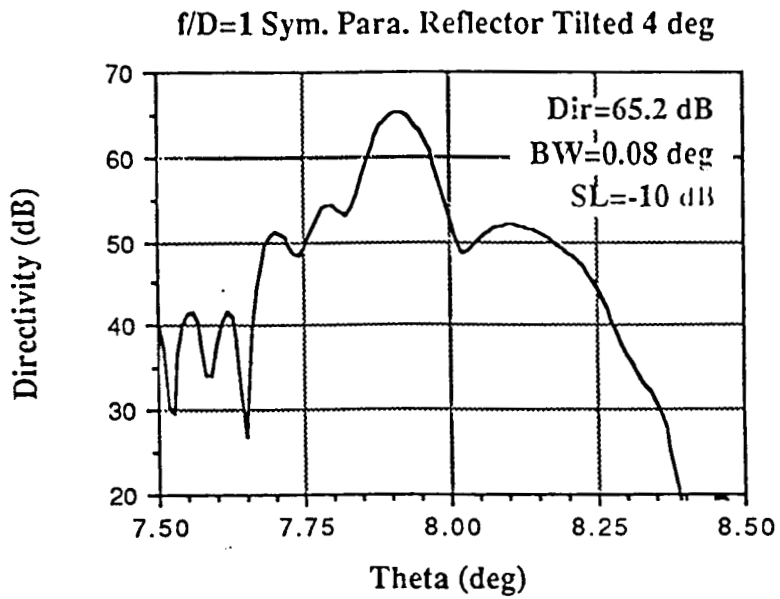

Figure 10. P2 symmetric parabolic reflector far-field pattern for 8° scan.

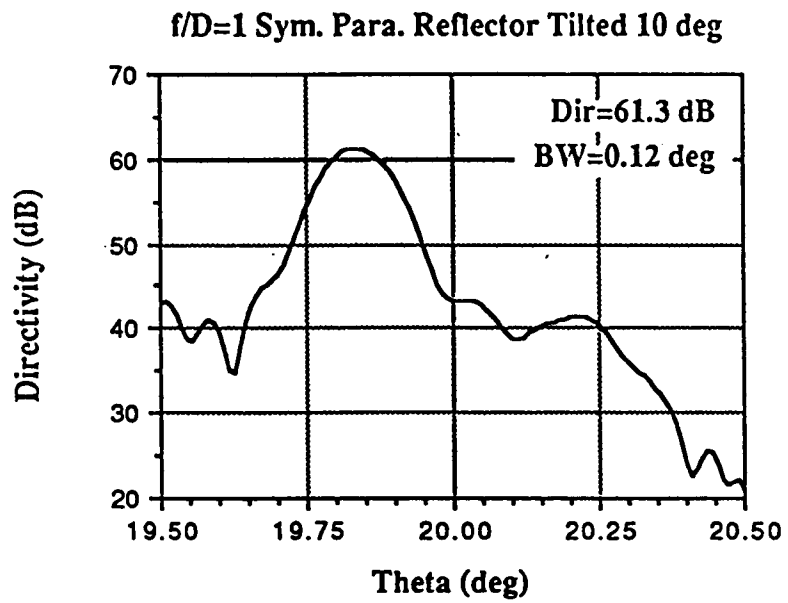
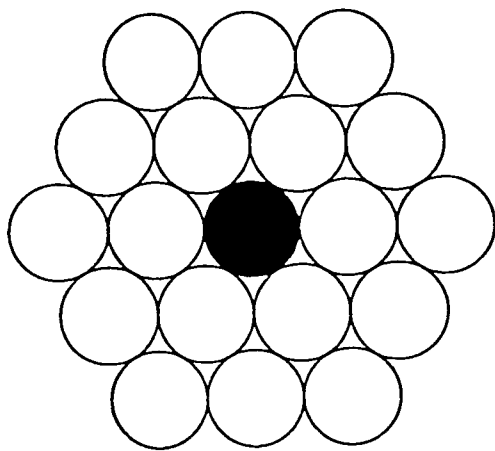
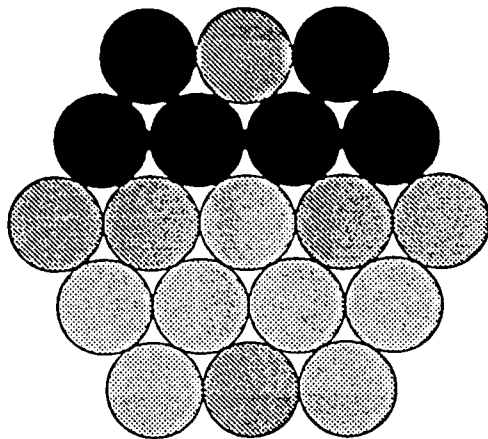

Figure 11. P2 symmetric parabolic reflector far-field pattern for 20° scan.



a.



b.

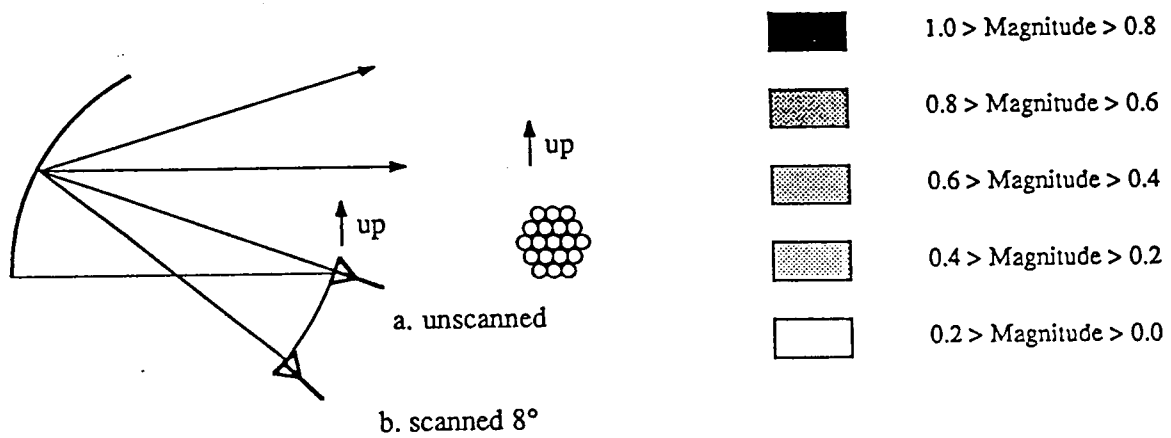

Figure 12. Relative feed excitations for the P3 off-set parabolic reflector.

a. Beam unscanned. b. Beam scanned 8°.

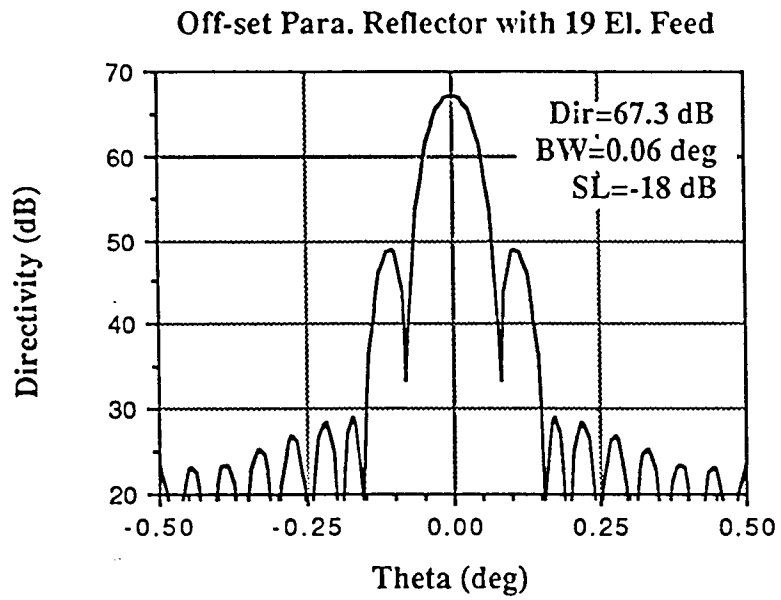

Figure 13. P3 off-set parabolic reflector far-field pattern for 0° scan.

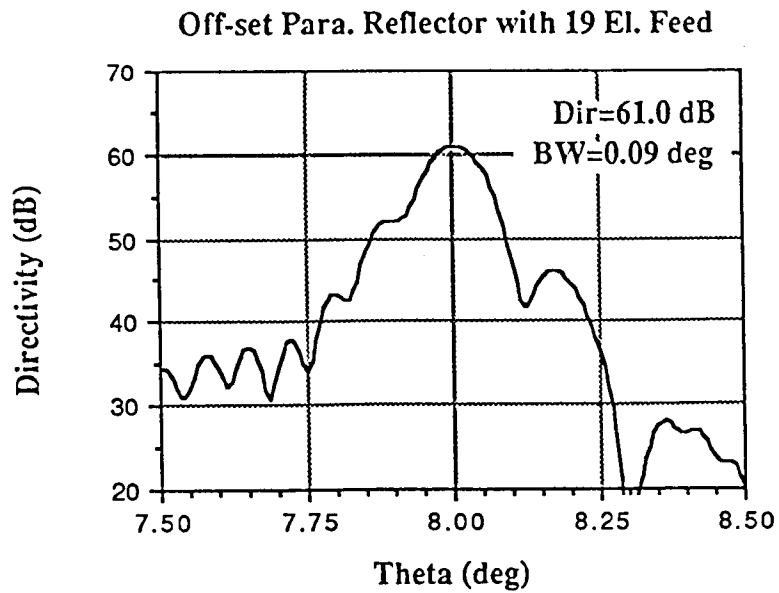

Figure 14. P3 off-set parabolic reflector far-field pattern for 8° scan.

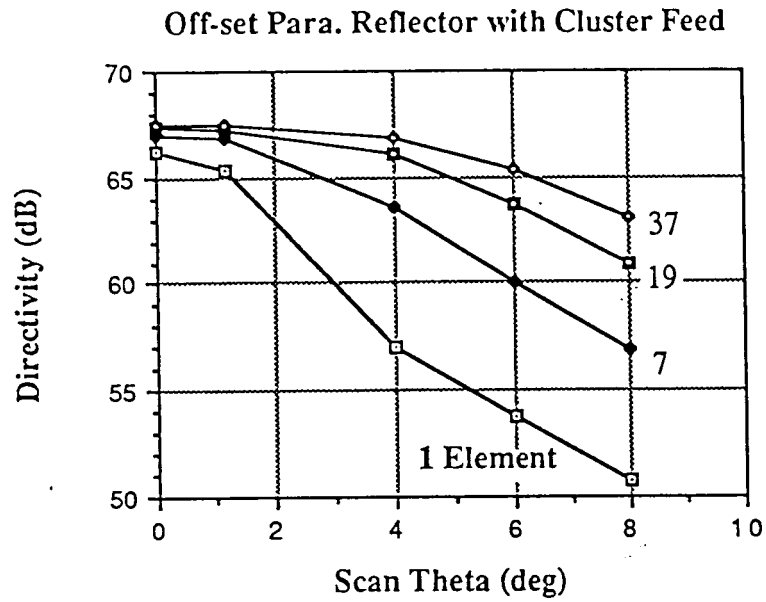

Figure 15. Directivity vs. scan for the off-set parabolic reflector. Note that as the number of cluster elements increases, so does the directivity.

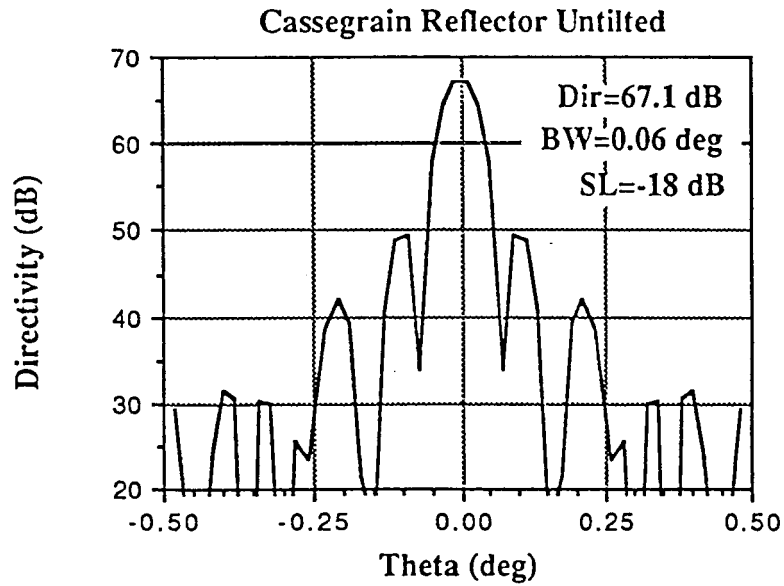

Figure 16. Symmetrical cassegrain reflector far-field pattern for unscanned beam. C1, C2, and C3 have identical patterns for this case.

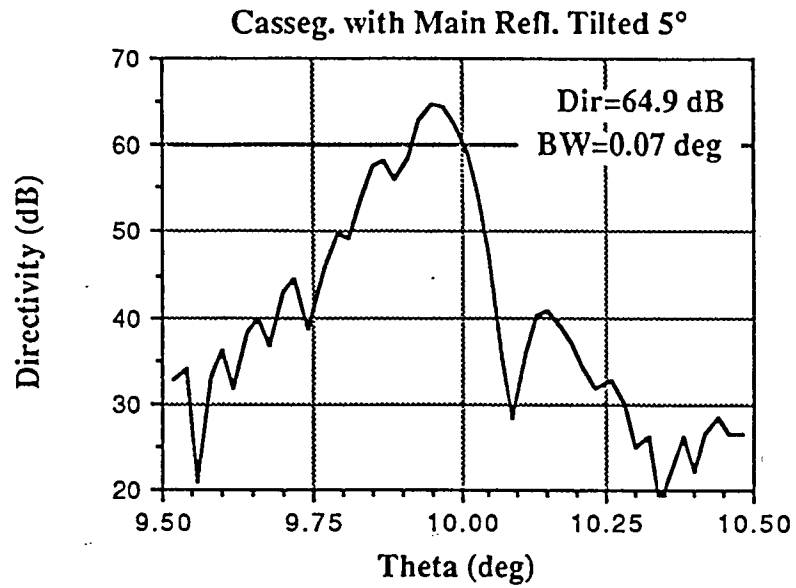

Figure 17. C1 symmetrical cassegrain reflector far-feild pattern with main reflector tilted to produce 9.96° scan.

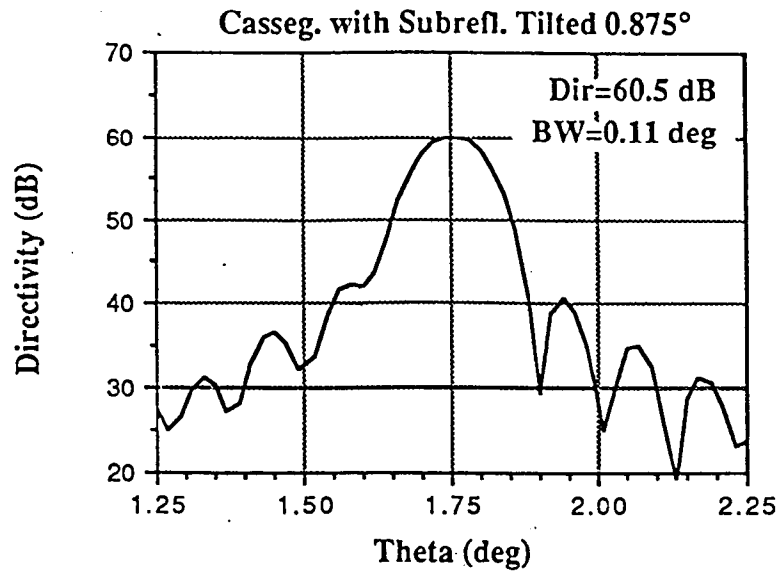

Figure 18. C2 symmetric cassegrain reflector far-field pattern with subreflector tilted to produce 1.75° scan.

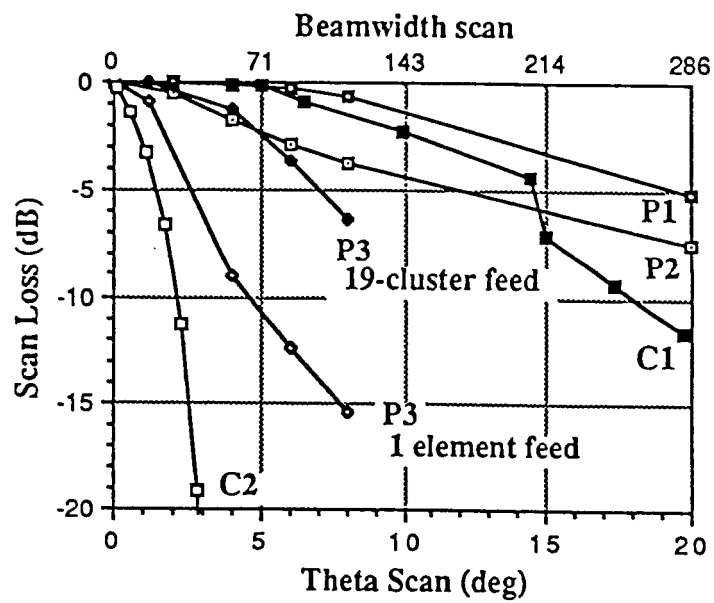

Figure 19. Scan loss of the six reflector antennas shown in Figures 1 and 2.

1. Report No. NASA TM-101459		2. Government Accession No.		3. Recipient's Catalog No.	
4. Title and Subtitle A Comparison of Reflector Antenna Designs for Wide-Angle Scanning				5. Report Date February 1989	
				6. Performing Organization Code	
7. Author(s) M. Zimmerman, S.W. Lee, B. Houshmand, Y. Rahmat-Samii, and R. Acosta				8. Performing Organization Report No. E-4569	
				10. Work Unit No. 650-60-20	
9. Performing Organization Name and Address National Aeronautics and Space Administration Lewis Research Center Cleveland, Ohio 44135-3191				11. Contract or Grant No.	
				13. Type of Report and Period Covered Technical Memorandum	
12. Sponsoring Agency Name and Address National Aeronautics and Space Administration Washington, D.C. 20546-0001				14. Sponsoring Agency Code	
15. Supplementary Notes Portions of this material were presented at the NASA Technology Workshop for Earth Science Geostationary Platforms, September 21-22, 1988 at NASA Langley Research Center, Hampton, Virginia. M. Zimmerman, S.W. Lee, and B. Houshmand, University of Illinois at Urbana-Champaign, Urbana, Illinois 61801; Y.Rahmat-Samii, Jet Propulsion Laboratory, Pasadena, California 91109; R. Acosta, NASA Lewis Research Center.					
16. Abstract Conventional reflector antennas are typically designed for up to ± 20 beamwidths scan. In this paper we try to stretch this scan range to some ± 300 beamwidths. We compare six single and dual reflector antennas. It is found that a symmetrical parabolic reflector with $f/D = 2$ and a single circular waveguide feed has the minimum scan loss (only 0.6 dB at $\theta_0 = 8^\circ$, or a 114 beamwidths scan). The scan is achieved by tilting the parabolic reflector by an angle equal to the half-scan angle. The f/D may be shortened if a cluster 7 to 19 elements instead of one element is used for the feed. The cluster excitation is adjusted for each new beam scan direction to compensate for the imperfect field distribution over the reflector aperture. The antenna can be folded into a Cassegrain configuration except that, due to spillover and blockage considerations, the amount of folding achievable is small.					
17. Key Words (Suggested by Author(s)) Antenna far-field Wide angle compensation Feed array			18. Distribution Statement Unclassified - Unlimited Subject Category 32		
19. Security Classif. (of this report) Unclassified		20. Security Classif. (of this page) Unclassified		21. No of pages 30	22. Price* A03