

A COMPARITIVE APPROACH OF ENERGY EFFICIENT STREET LIGHTING SYSTEMS

Sankaran Nampoothiri K¹, Arathy Ayyappan², Arundhathy Mohan³, Revathy R Krishnan⁴, Athira M⁵

^{1,2,3,4,5}Assistant Professor, Dept. of EEE, Sree Buddha College of Engineering for Women, Kerala

ABSTRACT: The energy wastage is proved a big problem in this modern life. Usage of the energy resources are increasing rapidly. The current scenario of the street light system is that it needs the man power to control the lighting system and the other problems associated with the conventional street light system is energy wastage .The street lights are seen in ON condition in the day time when not needed and in OFF conditions sometimes when needed most. To avoid these errors, the street lighting system is being controlled by GSM technology, Microcontroller and a Schmitt trigger circuit. A number of street light control system have been developed to control and to reduce energy consumption of a public lighting system. These ranges from controlling a circuit of street light and/or individual lights with specific ballasts and network operating protocols. These may include sending and receiving instruction via a separate data network, at a high frequency over the top of the low voltage supply or wireless. The control centre will deal with the data so that it can know the situation of each streetlight. A novel scheme for a Zig-bee based street light control is to proposed with an aim to reduce the human error in the operation of street lights, decrease the energy consumption of the system, and ease the maintenance of the street light network. These objectives are achieved by creating a wireless Zig-bee network of street lights that can be monitored from a base station. An automatic mode of operation that utilizes light sensors to automatically switch ON the street lights when light intensity falls below a certain level, has also been incorporated.

I. INTRODUCTION

A street light, light pole, lamp post, street lamp, light or lamp standard is a raised source of light on the edge of a road . Modern lamps may also have light-sensitive photocells that activate automatically, when light is not needed: dusk, dawn, or the onset of dark weather. The function in the older lighting systems could have been performed with the aid of a solar dial. Many street light systems are been connected underground, instead of wiring from one utility post to another. The use of street lighting was first recorded in the city of Antioch from the 4th century. Later it was recorded in the Arab Empire from the 9th–10th centuries, especially in Cordova, and then in London from 1417 when Henry Barton, the mayor, ordered" lanterns with lights to be hanged out on the winter evenings between Hallow tide and Candle masse [1]".

It was introduced in the US by inventor Benjamin Franklin, who was the postmaster of Philadelphia, Pennsylvania. This may be the reason, many regards Philadelphia as the birthplace of street lighting in the US. In the colonial-era period, streetlights were lit by candles placed inside a glass vessel, which kept the candle from being blown out by the wind. Franklin's design was four-sided, with four panes of glass separate, so that if one pane of glass was broken, the lamp did not need to be replaced entirely, and might not even blow out. William Murdoch invented the gas lighting in 1792; cities in Britain began to light their streets using gas. The United States followed this technique shortly afterwards with the introduction of gas lighting to Pelham Street in Newport, Rhode Island in 1803. In the 19th century, the use of gas lighting was increased. Some locations in the US still might use these gas lights [1].

Light bulbs were developed for the street lights , after Thomas Edison pioneered the electric use. The use of electric street lights was the first used by Wabash, Indiana. The City Council of

Wabash agreed to test the lights, and on March 31, 1880, Wabash became the "First Electrically Lighted City in the World" as a flood of light engulfed the town from four Brush Lights mounted atop the courthouse. One of the original Brush Lights is on display at the Wabash County Courthouse. By the beginning of the 20th century, the fire-based streetlight was dwindling as developers were searching for safer and more effective measure to illuminate their streets [1].

Incandescent lights and Fluorescent lights became popular during the 1930s and 1940s, when the automobile travel begins to flourish. A Street light was referred to as a white way during the early 20th century. Part of New York City's Broadway was nicknamed as the Great White Way due to the massive number of electric lights used on theatre marquees lining the street. A street light, light pole, lamppost, street lamp, light standard, or lamp standard is a raised source of light on the edge of a road. Modern lamps may also have light-sensitive photocells that activate automatically when light is not needed: dusk, dawn, or the onset of dark weather. The function in older lighting systems could have been performed with the aid of a solar dial. Many street light systems are being connected through underground, instead of wiring from one utility post to another. Intelligent street lighting refers to public street lighting that adapts to movement of pedestrians, cyclists and cars. Intelligent street lighting is also referred to as adaptive street lighting, dims when no activity is detected, but brightens when the movement is detected. This type of lighting is different from traditional, stationary illumination, or dimmable street lighting that dims at pre-determined times. The benefits of this type of technology are:

- Energy savings: Use of energy and costs decline because the lights are dim at night ,when there is a low activity.
- Maintenance cost reduction: Maintenance costs are reduced because it takes more time before the lamps have to be replaced.
- Reduction in CO₂ emissions: Energy reduction makes a reduction in CO₂ emissions.
- Reduction of light pollution: light pollution can be reduced to an such extent, because the street lights don't shine at full brightness anymore. Street scenes become calmer looking.
- Maintenance of safety: Safety is maintained, because the lights are dimmed, does not turned off completely. One might even argue safety improves because it becomes clear from far away when movement is approaching (the lights brighten) [1].

There are various intelligent street lighting systems now being used. Different papers were collected regarding various intelligent street lighting systems out of them six papers are selected to study these systems and found out their drawbacks.

II. "AUTOMATIC STREET LIGHT CONTROL SYSTEM USING MICROCONTROLLER"

In this paper, two kinds of sensors had been used which are light sensor and photoelectric sensor. The light sensor will detect darkness to activate the ON/OFF switch, so that the streetlights will be ready to turn on and the photoelectric sensor will detect the movement to activate the streetlights. LDR, will varies according to the amount of light falling on its surface, thus gives an induction for whether it is a day-night time, the photoelectric sensors are placed on the side of the road, which can be controlled by microcontroller PIC16f877A. The photoelectric sensor will be activated only at the night time. If any object crosses the photoelectric beam, a particular light will be automatically turn ON.

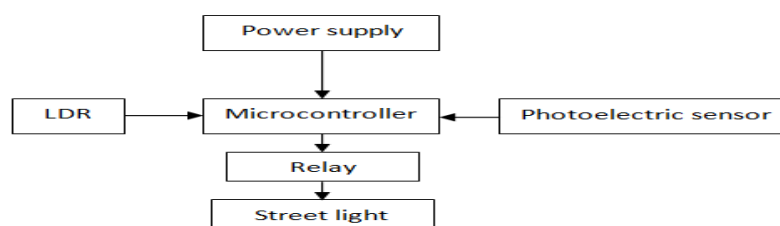

Fig 1. Block diagram of street Light system.

By using a basic principle, the intelligent system can be designed for the perfect usage of streetlights at any place. The block diagram of the street light system is as shown in figure 1 consists of a microcontroller, LDR, and a photoelectric sensor. By using this LDR, we can operate the street lights, i.e. when the light is available, then it will be in the OFF state and when it is dark the light will be in ON state, i.e. LDR is inversely proportional to light. When the light falls on the LDR, it sends a commands to the microcontroller so that it should be in the OFF state then it automatically switch OFF the light, the photoelectric sensor will be used to turn ON or OFF the light according to the presence or absent of the object. All these commands are sent to the controller then according to that the device operates. We use a relay to act as an ON/OFF switch. The theoretical concept of the light sensor lies behind, which is used in this circuit as a darkness detector.

III. GSM BASED STREET LIGHT AUTOMATION

The latest trends in the technologies related to wireless communication has led to the emergence of several engineering designs for human requirements. The creeping interest in the wireless and GSM based projects, came up with an idea of developing a simpler, multipurpose, cost-effective design to control the on-off street lights via through short message service (SMS). Commands are sent to the street light for night lighting. Applications system through mobile users as data are send through SMS (Short Service Messages) by providing a cost effective, reliable far reaching access to the user. Hardware implementation of Auto light intensity and Auto switching system control for Smart Street lighting system is proposed. AT COMMAND is used for functionality of street light just like server used. By sending a SMS on to microcontroller by the help of mobile they read it and match by itself. If the controller is accepting then, street light is ON vice versa for OFF. Contractor are used against to relay protect and control maintained of supply. There is an inbuilt circuit are here power supply are given to module therefore with the help of ac capacitor ripples are reduced and then converted into dc by the help of bridge rectifier by using antenna they transmit the MSG to micro controller the read and accept if they match with at command after then MSG should be received led light emitted. GSM based street light automation describes the new economical solution for managing the street light and power saving energy. This system consists of an electrical device, GSM modem and a control circuitry. The client server is directly connected with the web based application to control any street light from any one position. By using this java application maintained, the complete street light recorded if we wish to switch OFF/ON any particular street light, server will send a GSM SMS to that street controller to take action. Street controller will receive that SMS and will decode it and finds out the particular street light which needs to put ON/OFF by using relay circuit. The street controller 89C51 is connected to GSM modem through its UART port (Serial Ports). 89C51 cannot directly connect to GSM modem directly due to disturbance in the voltage levels. So modem is connected directly through voltage level convertor MAX 232. There are 2 lines TX (TRANSMITTER) & RX (RECEIVER) is connected to the MAX 232. The MAX232 is connected to GSM modem via through RS 232 cable. An oscillator circuit of 5 MHz is connected to the 89C51. One of its port of 89C51 is connected to relay driver circuit that helps the controller 89C51 to switch the power OFF/ON of the street lights. 89C51 will continuously reading the serial port after every second for the new SMS. Ones the SMS came, it will try to forward that SMS from GSM modem using AT commands.

GSM based street light automation describes the new economical solution for managing the street light and power saving energy. This system consists of a electrical device, GSM modem and control circuitry. The client server is directly connected with the web based application to control any street light from any one position. By using java application maintained, the complete street light recoded if we wish to switch OFF/ON any particular street light, the server will send a GSM SMS to that street controller to take action. Street controller will receive that SMS and will decode it and finds out the particular street light which needs to put ON/OFF by using relay circuit. Here the street controller 89C51 is connected to GSM modem through its UART port (Serial Ports). 89C51 cannot connect to GSM modem directly due to disturbance in voltage levels. So modem is connected

directly through voltage level convertor MAX 232. There are 2 lines TX (TRANSMITTER) & RX (RECEIVER) connected to the MAX 232. The MAX232 is connected to GSM modem via RS 232 cable. An oscillator circuit of 5 MHz is connected to the 89C51. One of the port of 89C51 is connected to relay driver circuit which will help 89C51 to switch power OFF/ON of the street lights.89C51 will continuously reading the serial port after every second for new SMS. Ones the SMS came it will try to forward that SMS from GSM modem using AT commands. It will decode it and finds the particular street light which needs to the entire street light lamps are connected to relay driver circuit. Base server will run a Java application which will maintain complete street when we want to switch ON/OFF any particular street light, server will send a GSM SMS to that street controller to take necessary action. Further, with By using the auto switching system of Smart Street light we can also reduce energy consumption because manually operating lighting system are not switched ON earlier before sunset and also not switched OFF properly after the sun rise. In healthy condition street light operates in a normal working condition by turning ON and OFF automatically for night and day light, but in unhealthy condition the street light does not turn ON or OFF and it sends a feedback message to control room to notify the host. The host is able to turn ON or OFF the street light manually and wirelessly with the help of graphical user interface. In a fault condition, the street light sends an Error message to the control room to alert the host or operator regarding the fault. The operator Notified and takes further action to carry out repair works. As compared to the conventional street lighting system, the smart street system offers high reliability, low maintenance. The feedback system allows the street light to respond with the control room reporting its daily status and condition .Mobile should not only use for MSG but also for web application.

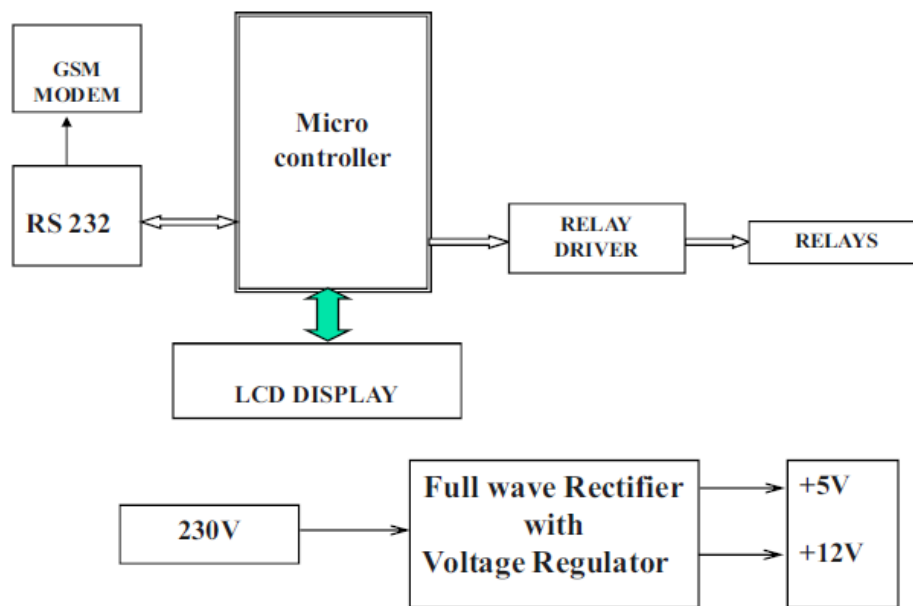

Fig 2 Block Diagram of GSM Based Street Light Automation

By sending a SMS to microcontroller circuit with the help of GSM circuit through a mobile, the unit of street light automatically switch ON/OFF. LED should indicate whether the street light is on or off and they should be control by using fix timer. Therefore time wastage and requirement of skilled worker is reduced to a greater extent. We can monitor and control more parameters and devices. It is used in various rooms like seminar hall, conference room, and study rooms in college where the capacity of room is limited and should not be exceeded. So the project will display the actual number of street light is work. Thus message is decide whether the street light should ON/OFF by the help of GSM and microcontroller circuit. It enables regulate their communication strategies according to dynamically changing network environment. Street lights should work on the systematic manner by the help of circuit and huge reduction in power consumption on whole around the world it is less costly and effective in manner.

IV. DESIGN AND IMPLEMENTATION OF AN AUTOMATIC STREETLIGHT CONTROL SYSTEM USING SCHMITT TRIGGER”

Street lighting system is a public key service provided and sustained by public authorities at the local, state and even at federal levels. Efficient lighting is paramount and vital for road safety, human safety and urban beautification. The first street lighting system was brought up, to focus in the Arab Empire from the 9th to the 10th century in Cordoba, Spain and lamps filled with vegetable oil were used. The oil lamps were operated by special slaves who have to ensure the oil is never exhausted in the lamps. Today, most of the street lights are manually operated despite several street lighting control technologies have been developed.

Proposed a cost effective automated street lighting control system which depends on a microcontroller based intelligent management of the lamp posts activities of pedestrians, automotive traffic and ambient light conditions. Developed a street light control system featuring two sensors, a light sensor and a photoelectric sensor, and uses a PIC microcontroller to operate the lamps. Proposed is a GSM-Based RFID approach to automatic street lighting system. In this system, automatic street light is designed to control system using a simple light dependent resistor (LDR). The system uses one sensor and does not require a microcontroller as it is simple but is efficient in regulating the state of the street lights. The project is based on UA741 operational amplifier which is configured as a Schmitt trigger and a light dependent resistor (LDR).

During the daytime, the LDR senses enough illumination and the security light goes OFF. And at the night time, the resistance of the LDR increases and causes the light to turn “ON”. Also, a transistor switching occurs, a 12V Relay is deployed to provide the switching mechanism to activate the street lights connected in parallel. Manual operation of streetlight is needed and much energy is saved that would have been otherwise wasted if the user were to forget to power “OFF” the light at any point in time. This work has been successfully designed, implemented and commissioned for use. The LDR and the 100K variable resistor form a voltage divider network. When the voltage across the variable resistor is small at the dark time, as most of the voltage is dropped across the LDR and as such the reference voltage V_{ref} at the non-inverting terminal (pin 3) is higher than the voltage across the inverting terminal (pin 2) of UA 741 Operational Amplifier. The operational amplifier will produce a positive voltage of 12Volts at the output terminal (pin 6). The voltage is fed through a voltage divider network comprising R5 and R6 which drives the bipolar transistor, C945 to switch the Relay that activates the street lamps.

The power supply consists of a 12V step down transformer, a bridge rectifier I.C, a 50V/2200uf capacitor and a 12V voltage regulator. The step down transformer transforms the alternating current voltage from 220V to 12V ac. The bridge rectifier I.C consists of four diode rectifier internally and converts the ac Voltage to dc Voltage. The 50V/2000uf capacitor filters the output dc voltage from the rectifier ac in to a pure dc voltage, while the 12V ac the voltage regulator ensures that the voltage is stabilized at 12Volts. The light dependent resistor is a resistor whose value varies on intensity of light. When light falls on it, the resistance reduces and increases when exposed to darkness. The inverting Schmitt trigger circuit uses a uA741 operational amplifier and a positive feedback is provided by resistor, R4. Pin 2 of the Op-amp is the inverting input while Pin 3 is the non-inverting input. Pin 6 represents the output terminal while Pin 7 and Pin 4 are for +VCC and -VCC respectively. R2 and R3 is the potential divider network to determine the reference voltage V_{ref} . The voltage at the non-inverting input terminal (V_+) is determined by V_{ref} and the output voltage, figure 3 shows the circuit as described below.

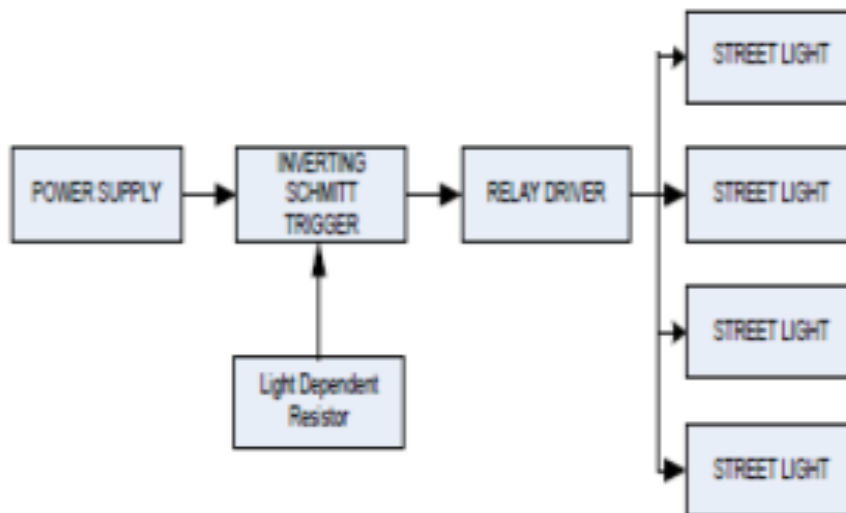

Fig 3 Street Lighting System Using Schmitt Trigger

The system utilizes an inverting Schmitt trigger circuit, that relies on the light sensitive component called light dependent resistor (LDR). The amount of light falling on the LDR, determines the resistance. The LDR and the 100K variable resistor form a voltage divider. The voltage across the variable resistor is small when it is dark, and most of the voltage is dropped across the LDR. And in such condition, the voltage across the inverting terminal (pin2) of UA 741. Reference voltage V_{ref} is higher than operational amplifier at the non-inverting terminal (pin3). The operational amplifier will produce a positive voltage of 12Volts at the output terminal (pin 6). The voltage is fed through a voltage divider network comprising R5 and R6 which drives the bipolar transistor, C945 to switch the Relay. The Double Pole Double Throw (DPDT) Relay makes contact to switch “ON” the two security lights. A flywheel diode is connected across the Relay to protect the contact against “back-emf” generated by the magnetic field of the Relay coil. When light shines on the light dependent resistor, the resistance reduces depending on the amount of light and the voltage across the variable resistor increases. This voltage is applied to the inverting terminal (pin2) of the UA741 operational amplifier configured as a Schmitt trigger.

V. RESULT & DISCUSSION

In this modern world people are forced to use more and more electronic devices in their daily life. Among, these electronic control systems deserve most importance. The strain and time of people in their day- to- day life are reducing to the minimum by the use of such systems. We studied three papers regarding automatic streetlight control. Out of those papers, GSM controlled streetlight monitoring system is the most efficient one since it helps in long range wireless communication.

VI. CONCLUSION

Automatic street light system using microcontroller, GSM based automatic street illumination system for efficient power system, intelligent street light system using wireless transmission, GSM based street light automation, intelligent automatic street lighting system with advanced control through GSM model, design and implementation of an automatic street light control system using Schmitt trigger etc. were studied in detail and identified the drawbacks of each. Following are the drawbacks of the systems studied. Schmitt trigger circuit makes the entire circuit complex, operating cost is high, and any failure to the power supply unit affects the overall performance of the system. Disadvantages of GSM Technology based systems are, their maintenance and repair is difficult, it causes ranging problems and is complex.

REFERENCES

- [1] “GSM Based Autonomous Street Illumination System for Efficient Energy Management”, Prof. K.Y, RaJput,Gargeyee Khatav,2013.
- [2] “GSM Based Street Light Automation”M SharizAnsari, Tanmay Srivastava”,2015.
- [3] “Intelligent Automatic Street Lighting System with Advance Control through GSM Modem”,Mr.UmeshG.Phonde, Dr.Uttam.L.Bombale”,2014.
- [4] “Automatic Street Light Control System Using Microcontroller”,Mustafa Saad, Abdalhalim Farij,2013.
- [5] “Intelligent Street Light System Using Wireless Transmission”,SakshiAnand, Dr.Neelu Jain,2015.
- [6] “Design And Implementation Of An Automatic Street Light Control System Using Schmitt Trigger”IsahAbdulazeez Watson, Oshomah Abdulai Braimah”,2015.
- [7] “ZigBee-based Intelligent Street Lighting System”, Sagar Deo, Sachin Prakash ,2014.
- [8] “Development of ZigBee based street light control system”,Lee,J.D.Nam
- [9] “Inventi+ng the lighting Century” Neal Baldwin, Edison, 1995.