



A Comprehensive Review of the Integration of Battery Energy Storage Systems Into Distribution Networks

MARCO STECCA  (Student Member, IEEE), **LAURA RAMIREZ ELIZONDO** (Member, IEEE), **THIAGO BATISTA SOEIRO**  (Senior Member, IEEE), **PAVOL BAUER**  (Senior Member, IEEE),
AND PETER PALENSKY (Senior Member, IEEE)

Electrical Sustainable Energy Department, Delft University of Technology, Delft 2628 CD, The Netherlands

CORRESPONDING AUTHOR: M. STECCA (e-mail: m.stecca@tudelft.nl)

ABSTRACT Recent developments in the electricity sector encourage a high penetration of Renewable Energy Sources (RES). In addition, European policies are pushing for mass deployment of Electric Vehicles (EVs). Due to their non-controllable characteristics, these loads have brought new challenges in distribution networks, resulting in increased difficulty for Distribution System Operators (DSOs) to guarantee a safe and reliable operation of the grid. Battery Energy Storage Systems (BESSs) are promising solutions for mitigating the impact of the new loads and RES. In this paper, different aspects of the BESS's integration in distribution grids are reviewed. At first, the physical layer will be considered, focusing on the main battery technologies commercially available and on the power electronics converter. Secondly, the different functionalities that a grid-connected BESS can provide will be investigated, and then its sizing, location and control in distribution network will be discussed. In addition, an overview of actual BESSs installations is given. All in all, this paper aims at providing a comprehensive view of BESSs integration in distribution grids, highlighting the main focus, challenges, and research gaps for each one of these aspects.

INDEX TERMS DC-AC power converter, distribution network, energy storage.

I. INTRODUCTION

The existing electrical networks have been designed according to the old paradigm that foresees mainly large generation plants, connected at the transmission grids, providing most of the required energy. Distribution grids, instead, have been planned to host consumption points and not distributed generation. The increase of solar and wind energy production, together with the introduction of new types of loads, as electric vehicles and heat pumps, have brought heavy changes in distribution networks [1], [2]. For these reasons, Distribution System Operators (DSOs) now face new technical challenges, especially due to the unpredictable nature of solar and wind power and of Electric Vehicles (EVs) charging stations [3]–[5]. Energy Storage Systems (ESSs) might be a valid alternative to network reinforcements. However, their benefits and economic viability

are not completely clear [6]. In addition, adverse policies might hamper the deployment of such systems [7]–[9]. Although many energy storage technologies have been developed, the focus of this work is on battery-based energy storage systems.

Due to their flexibility and expected decreasing costs [10], [11], Battery Energy Storage Systems (BESSs) have attracted the attention of the scientific community, resulting in a considerable number of studies. Several energy storage technologies are presented in [12], [13], article [14] provides an economic analysis of storage technologies, whereas in [15] the possible grid applications are discussed. BESSs' placement and sizing techniques are considered in [16]–[19]. Whereas article [20] also discusses ESS control and a few case studies. Regarding the converter topology specifically for energy storage, a survey is given in [21], whereas [22]

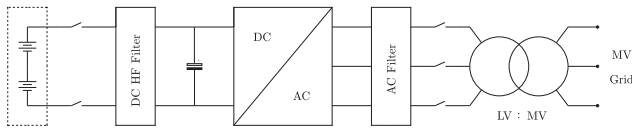

FIGURE 1. Basic schematic of a grid-connected battery energy storage system.

presents a comparative analysis of efficiency and costs between the main circuit topologies.

Technical aspects such as BESS components, functionality, planning, control, and installations are generally studied and reviewed independently from each other. This paper, instead, aims to provide a comprehensive view of BESSs integration in AC distribution grids. At first, in Section II, the main electrochemical storage technologies and the possible research gaps related to the design of grid-connected power electronics converter for battery energy storage are investigated. Secondly, in Section III, the main BESS electrical services will be discussed, providing insights on the possible applications and the deriving revenues. Moreover, in Sections IV and V, it will be shown how the studies related to energy storage planning and control differ in terms of BESS ownership, modeling, and application for which the storage is deployed. Finally, in Section VI, energy storage installations and pilot projects will be considered, to analyze how and to what extent BESSs have been deployed and which are the key players in the commercialization of storage systems. Section VII presents the conclusion of this review.

II. BATTERY ENERGY STORAGE SYSTEMS COMPONENTS

In this Section the physical components of battery energy storage systems are investigated. Fig. 1 shows a circuit schematic of a grid-connected BESS. The main components are the battery bank, the DC-AC converter, the DC and AC filters, the protection circuits, and the step up transformer. The parts by interest considered in this Section are the battery bank and the power electronics converter.

A. ELECTROCHEMICAL BATTERY TECHNOLOGIES

The main electrochemical technologies that have been used in grid applications are lithium-ion, sodium-sulfur, lead-acid, and redox flow batteries. Grid-connected electrochemical storage is characterized in terms of energy density, efficiency, lifetime, and costs, as illustrated in Figs. 2 and 3 and discussed in the following.

Lead-Acid batteries were the first rechargeable battery technology invented in 1889 by the French physicist Gaston Planté. Nowadays lead-acid batteries are considered a mature technology, which is characterized by a low cell cost (50-600 \$/kWh) and good efficiency (80-90 %) [23], [28], [29]. Their main drawback is the low cycling life (up to 2500 cycles), compared to other technologies, [23], [24] and low energy density (20–30 Wh/kg). Besides, lead-acid batteries lifetime is negatively affected by a high depth of discharge [30], [31].

Sodium-sulfur (NaS) batteries were developed by NGK Insulators Ltd in collaboration with TEPCO. NaS batteries are characterized by high operating temperature (around 300° C), reasonable efficiency (>80%), high energy density (in the range of 150-240 Wh/kg) and long cycling life (up to 4500 cycles) [32], [33]. This technology has been already adopted as grid-connected energy storage to mitigate the impact of renewable energy based generators [14], [33], [34].

Redox Flow (RF) batteries were first developed by NASA in 1974 [35]. They consist of two separate tanks, where the two chemical reactants are contained, and two electrodes separated by a membrane, where the two components are combined and the reaction of oxidation-reduction (redox) occurs. The energy capacity of flow batteries is defined by the amount of reactants stored in the tanks, whereas the power is defined by the electrodes and membrane system. Power and energy ratings are then separated, and this adds flexibility in the design and operation. Redox flow batteries have a low energy density (15–30 Wh/kg) and efficiency up to 75% [36]. Nevertheless, flow batteries are not subject to limitations in terms of reactants' life cycle and by the depth of discharge [37]. Besides the technical peculiarities, redox flow batteries have been recognized as a potential candidate for grid-scale storage also due to their economic performance [38]. Several chemical compositions for the reactants have been studied and proposed. However, Vanadium based and Zn-Br are the most prominent ones [39].

Lithium-ion batteries were firstly commercialized by Sony in 1991. The electrochemical properties of Li-ion batteries are defined by the chemical composition of the cathode, typically a lithium metal oxide, and of the anode, typically graphite [25]. This technology shows high efficiency, that can reach over 90%, although some commercial products offer a rated round trip efficiency over 95% [40], high energy density (90–190 Wh/kg) [41], and a long lifetime, that can reach up to 10000 cycles depending on the Li-ion chemistry, as shown in Fig. 3 [24], [25]. The lifetime is nonetheless affected by the cell temperature, which is a critical factor in the degradation process [42]. Li-ion batteries have been widely used in electronics devices, and in recent years, it has become the main technology for EVs. Despite being still relatively expensive, this technology is well suited for grid-connected applications [10]. Today many Li-ion technologies exist, e.g., Lithium cobalt oxide-based (LiCoO₂), Lithium manganese oxide-based (LiMn₂O₄), Lithium nickel oxide-based (LiNiO₂), Lithium nickel cobalt aluminium oxide-based (LiNiCoAlO₂), Lithium nickel manganese oxide-based cobalt (LiNiMnCoO₂), Lithium titanate oxide-based (Li₂₄Ti₅O₁₂), and Lithium iron phosphate-based (LiFePO₄) [43]. Fig. 3 presents the performances of (a) Lithium iron phosphate, (b) Lithium nickel manganese cobalt and (c) Lithium nickel aluminium cobalt [24], [25]. Between the considered electrochemical compositions, Lithium nickel manganese cobalt based technology, NMC, offers the best performances. Its good performances, among other factors, have contributed to bringing about NMC as the primary Li-ion technology for

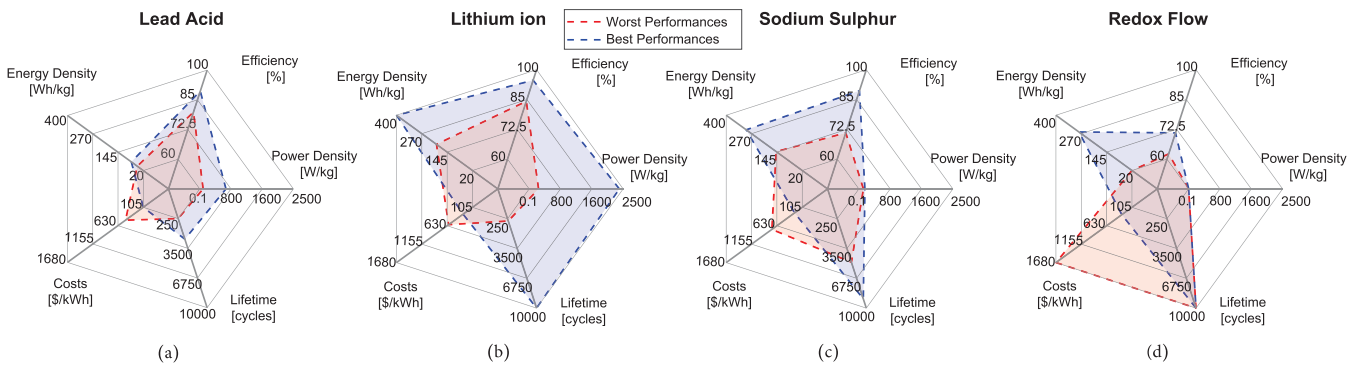

FIGURE 2. Performances of different electrochemical battery technologies: (a) Lead Acid, (b) Lithium ion, (c) Sodium Sulphur, and (d) Flow Battery – author’s elaboration from [23], [24].

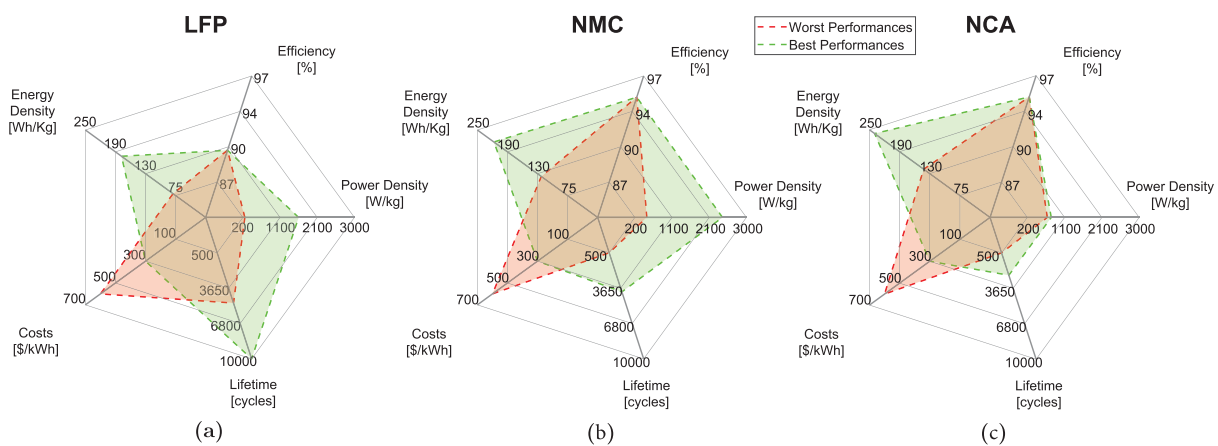

FIGURE 3. Performances of different Li-ion battery technologies: (a) Lithium iron phosphate, (b) Lithium nickel manganese cobalt, and (c) Lithium nickel aluminium cobalt – author’s elaboration from [24], [25].

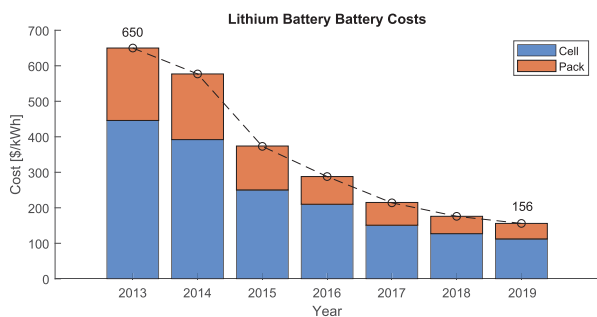

FIGURE 4. Costs of lithium-ion battery cell and pack over the last years – author’s elaboration from [26], [27].

stationary storage and EVs [44], [45]. Fig. 4 shows the cost of lithium-ion battery cells and pack over the past years [26]. What stands out is the substantial cost reduction, roughly –75% in 6 years, from 650 \$/kWh in 2013 to 156 \$/kWh in 2019. Following this trend, further cost reduction is expected. Consequently, with a lower total cost of ownership (TCO), energy storage systems could further establish themselves in the electricity sector.

Figs. 2 and 3 illustrate the main performance indicators of the electrochemical battery technologies previously discussed. Lithium-ion batteries outperform the other technologies, offering higher power and energy density, efficiency, and low daily self-discharge. Consequently, they have been the preferred choice by the industry, as it will be discussed in Section VI.

B. POWER ELECTRONICS DC-AC CONVERTER

The connection of battery storage systems to the AC distribution grid is made through power electronics based converters. In lithium-ion and lead-acid batteries based storage systems, the Power Conditioning System (PCS) accounts for a minor part of the total costs, as Fig. 5 shows, however the decreasing trend of battery cells costs, illustrated in Fig. 4, will lead to a higher share of costs for the PCS, as also foreseen in [24]. In this perspective, it is advisable to design the power electronics converter to ensure high efficiency and reliability, i.e., to limit the total cost of ownership [14].

Batteries have some peculiarities that need to be considered for the inverter design. The cells’ terminal voltage variations between fully charged and fully discharged status can be up

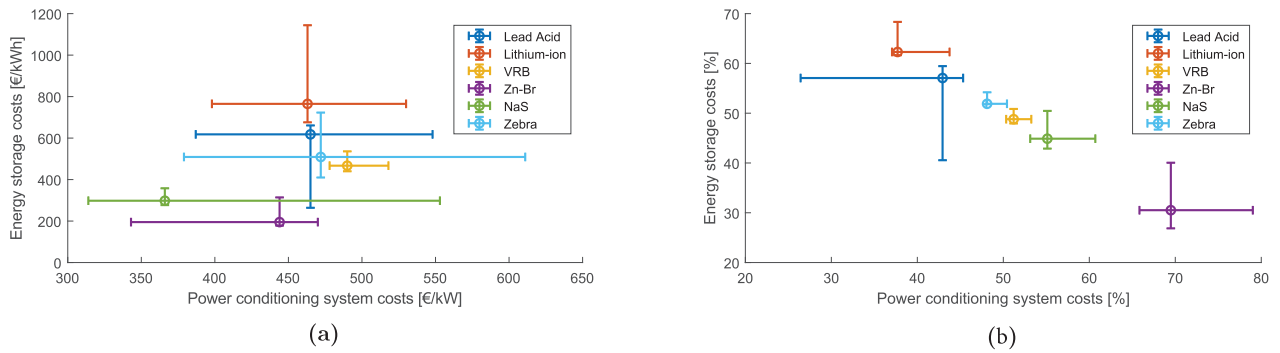

FIGURE 5. Energy storage systems (a) absolute and (b) relative costs for different electrochemical technologies, (b) refers to battery energy storage systems designed for 1–C application, so that the ratio of the BESS rated kWh/kW is equal to 1, e.g. a 1MW/1 MWh system—author’s elaboration from [14].

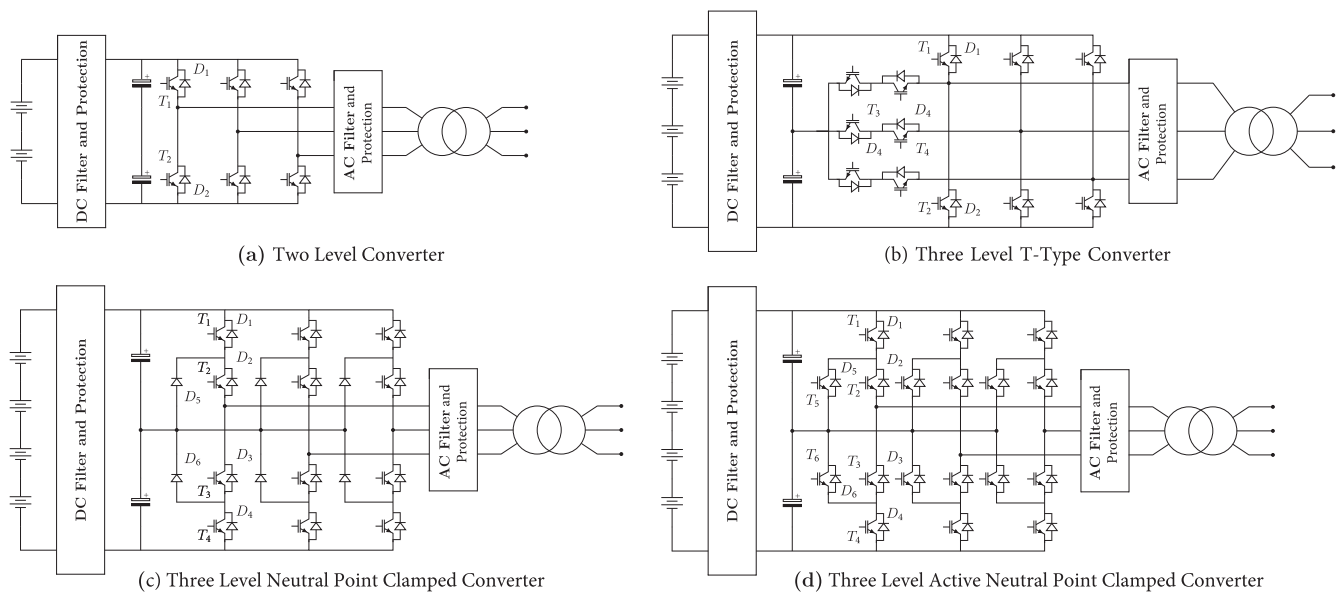

FIGURE 6. Transformer based Two Level and Three Level DC-AC converter topologies: (a) Two Level VSC, (b) Three Level T-Type VSC, (c) Three Level Neutral Point Clamped VSC, and (d) Three Level Active Neutral Point Clamped VSC.

to 40% [46]. Moreover, to ensure a highly efficient DC-AC conversion, the AC voltage should be kept as high as possible, to reduce the current stress in the semiconductors, which is the dominant source of loss within the power electronics converter.

Whereas the maximization of the efficiency will push for increasing the rated AC and DC voltages, the international norms fix the boundary between low and Medium Voltage (MV) at 1.5 kV [47], with additional safety requirements for appliances working at MV. Besides, the series connection of a high number of battery cells can lead to lower system reliability [48]. Furthermore, the limitations and requirements in terms of safety, harmonic content, and P-Q capabilities set by the technical standards and national grid codes need to be considered [49], [50].

Power electronics converters can be firstly classified depending on the presence or not of a step-up transformer, moreover, when transformers are not adopted, the step-up in

voltage, necessary for the connection at MV, can be achieved through the series connections of semiconductors or sub-modules. Also, the DC voltage can be controlled through an auxiliary DC-DC converter placed in between the battery and the grid connected DC-AC converter. However, the extra conversion step adds complexity, costs and it can lead to additional power losses. This choice needs to be justified by technical or operational challenges. Two Level (2 L) Voltage Source Converters (VSCs), shown in Fig. 6(a), are the preferred choice by the industry for interfacing stationary energy storage with the MV grid [51], [52]. However several other topologies, such as Three Level T-type, Neutral Point Clamped (NPC) converter, and Active Neutral Point Clamped (ANPC) converter, shown in Fig. 6(b)-(c)-(d) respectively, have been developed [21], [22].

Fig. 7 shows the semiconductors module efficiency for 100 kW Two Level and Three Level VSCs connected to a 400 V line-to-line AC grid with different switching

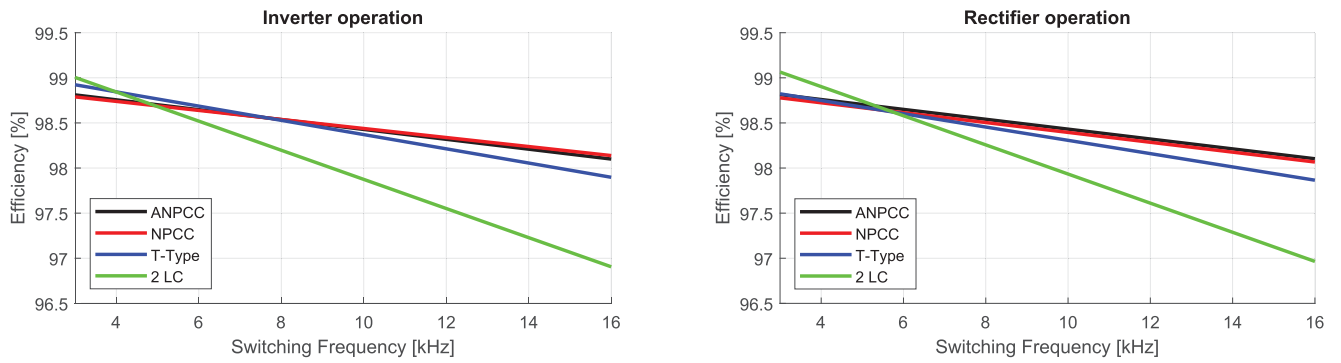

FIGURE 7. Efficiency at rated power of PWM Modulated Two Level and Three Level VSC topologies operating at different switching frequency for the converter specifications given in Table 1.

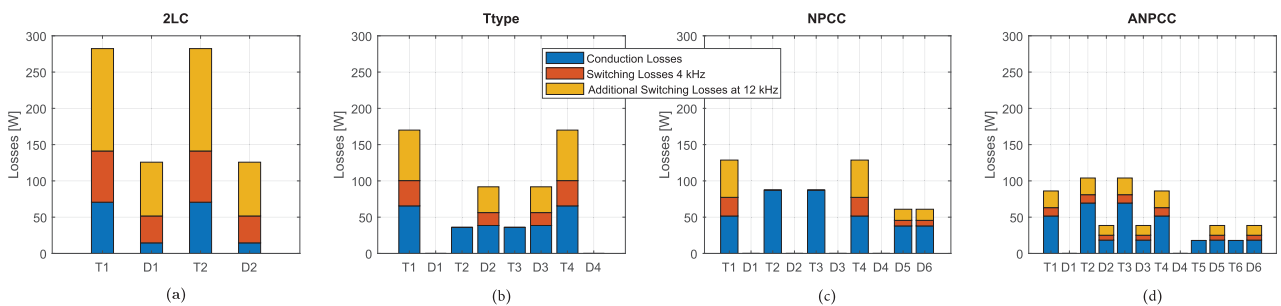

FIGURE 8. Losses distribution in Two Level (a) and Three Level (b)-(c)-(d) topologies during inverter operation, with switching frequency $f_s = 4$ kHz (blue+red) and $f_s = 12$ kHz (blue+red+yellow), considering the specifications in Table 1 and the components nomenclature of Fig. 6.

TABLE I Specifications Considered for the Efficiency and Loss Distribution Comparisons Between Circuit Topologies

Parameter	P_n	$U_{DC,n}$	$U_{ac,ll}$	$\cos \varphi$	f_s
Value	100 kW	900 V	400 V	1	3-16 kHz

frequencies f_s . The converter specifications are given in Table 1. For the analysis, appropriately rated IGBT-Diode modules from [53] are chosen. Three Level topologies outperform Two Level converters at higher switching frequencies, moreover, in particular Neutral Point Clamped topologies, show a better distribution of losses between the components, as displayed in Fig. 8. Further advantages from higher switching frequencies derive from the lower volume of the AC output harmonic filter, thus increasing the converter power density and the shifting away from the human audible noise frequencies. In reality, large grid-connected BESS are confined in containers and mostly installed away from people, which allows the power electronics to operate at low switching frequencies, e.g., 4 kHz, well within the human audible noise range. This leads to low switching loss across the semiconductors, displayed in red in Fig. 8. Additionally, Two Level VSC displays outstanding conduction losses, as depicted in Fig. 8, which justify its wide utilization at those low levels of f_s .

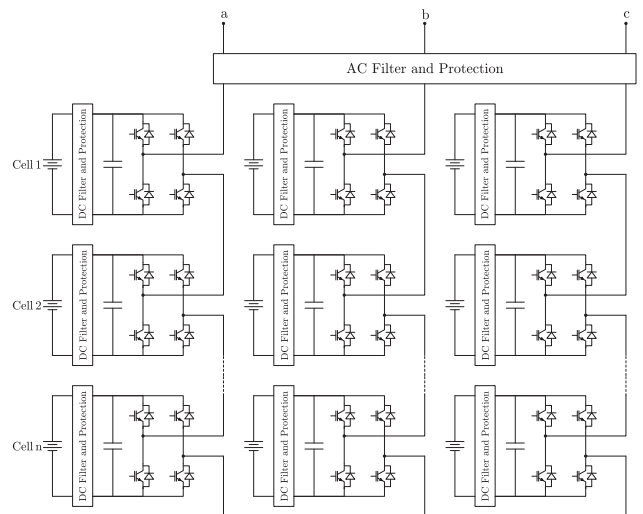

FIGURE 9. Three Phase DC-AC Cascaded H Bridge.

The cost comparison for energy storage MV converters presented in [22] indicates that Cascaded H Bridge (CHB), shown in Fig. 9, is a cheaper solution with respect to classic topologies, Two and Three Level converters, and the Modular Multilevel Converters (MMCs), depicted in Fig. 10. Multilevel topologies, such as the CHB and MMC, have been

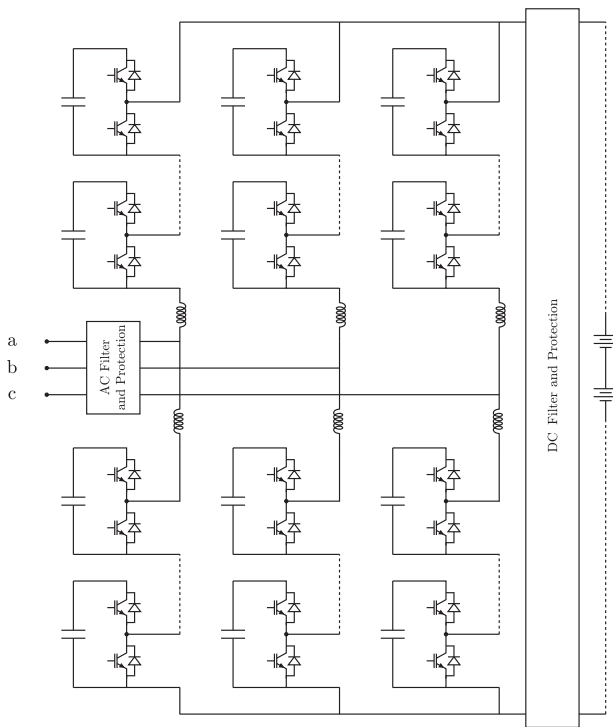

FIGURE 10. Three Phase DC-AC Modular Multilevel Converter.

proved well performing circuit topologies for grid connected energy storage applications; providing a lower overall harmonic content, high power density, and high efficiency at high switching frequency [22], [52], [54]–[56].

The reliability of energy storage systems, considering power electronics and battery cells, is studied in [48]. The authors performed a comparative study between two BESS configurations, a fully rated 2 L converter, and four partially rated 2 L converters. The two configurations are tested under different operating conditions, number of cycles that the battery cells are performing, battery power, and series-parallel cell configurations. The study highlighted how low power applications could ensure higher reliability. Moreover, it was found that there is an inverse proportional relationship between reliability, power level, and the number of cycles. This study can be a reference for further reliability analysis and comparisons between different topologies and battery’s cell configurations.

C. DISCUSSION

From the literature considered, it is found that despite the Two Level VSC is the most used topology for grid-connected BESS converters, alternative topologies can guarantee better performances in terms of efficiency, cost, power density, and system reliability. Furthermore, the influence of the operating conditions and then of the battery functionality on converters efficiency and reliability has been proved. Nonetheless, few researches show how BESS cost of ownership is influenced by adopting a more performing converter, in this context and

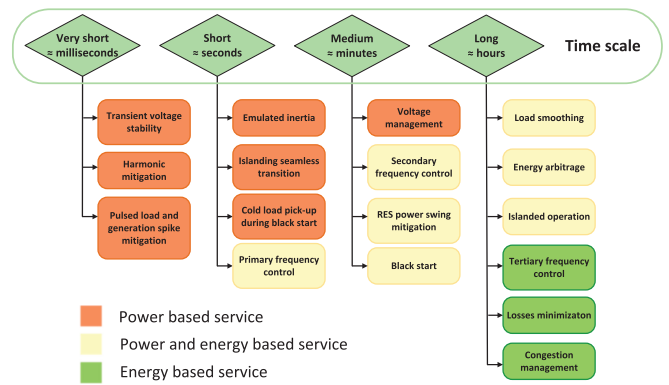

FIGURE 11. Ancillary services provided by BESS—author’s elaboration from [68].

from the insights gained from Figs. 7 and 8, further work can be focused on showing how different converter topologies impact on BESSs technical and economic performances. It is also essential to perform this analysis for different grid functionalities, such as the ones discussed in Section III, showing how the different operation requirements affects the DC-AC converter performances and design.

III. APPLICATIONS OF GRID CONNECTED BATTERY ENERGY STORAGE SYSTEMS

Grid-connected energy storage systems might be used to provide several services to grid operators, Distributed Generators (DGs) plant owners, energy retailers, and consumers [28], [57]. Fig. 11 lists some possible grid applications and classify them as power or energy intensive, meaning that their provision requires high energy reserve or high power capability, and according to the time scale of their deployment, from milliseconds to hours. Before analyzing how storage has been applied for the provision of these services, it can be useful to have an overview of the services themselves.

A. POWER QUALITY

Power quality indexes are used to measure the distortion of the voltage and current waveform with respect to an idealized pure sinusoidal one. Distortions can have a transient characteristic, for example, in the turning on or off of loads or generators, or be constant at steady state, for instance, due to the operation of non-linear loads or power electronic interfaced generation [58]. Energy storage has been investigated for this application, and it has been proved an effective solution [59], [60].

The rise of intermittent power sources has as well brought forward the issue of power swing in the network. The solar irradiation and wind speed fluctuations can lead to a sudden high variation of Distributed Generation plants and this can negatively affect the network. In this context, energy storage can be added to the DG plant and used to buffer the short term power variation [61]–[63]. When deployed for this scope BESS represent an additional cost component to the RES

plant, decreasing the system revenue. In this context, economic incentives to the plant owners for the power fluctuation mitigation might be a way to offset the revenue losses [63].

In addition to the voltage waveform measurements and to the output power fluctuations, also the continuity of service is monitored. System Average Interruption Frequency Index (SAIFI) and System Average Interruption Duration Index (SAIDI), between the many available indexes, are used to define the DSOs' remuneration bonus. Moreover, national grid codes can foresee fines or payments from DSOs to the users in case of service interruptions [64]. In the context of improving the continuity of service of distribution grids, energy storage systems can be implemented to facilitate the black start procedures and to allow the islanding operation of the distribution feeder. These two situations are consequent of one or multiple faults that bring a portion of a distribution network to operate disconnected from the main transmission grid. In the case of blackouts, storage systems could be integrated into the grid restoration plans and facilitate the recovery procedure [65]. Besides, high penetration of distributed generation together with storage systems could allow a safe operation also during unintentional islanding [66]. In a hypothetical islanding procedure, BESSs will be required to monitor and mitigate the transient due to the fault, and the sudden load-generation unbalance to have a smooth transition between grid-connected and islanded mode [67].

B. VOLTAGE CONTROL

Voltage control in distribution grids can be performed through several devices, among them tap changers, capacitor banks, voltage regulators, and static VAR compensators [65], [70]. However, as previously discussed, it might be necessary to add extra flexibility in managing distribution grids, and BESSs can play a crucial role in the future paradigm of voltage management. Since DG injection could make ineffective the regulating devices at the substation, such as transformers tap changers, the possibility of having several units distributed along the network, able to selectively generate reactive power, could allow an easier voltage control [71]. The implementation of storage units in the voltage control scheme has been proved technically effective [72], [73].

The voltage profiles of one of the two main feeders of the IEEE European test network, displayed in Fig. 12, are evaluated and plotted in Fig. 13. Fig. 13(a) shows the voltage profile before and after the introduction of PV generators, it is possible to see how the photovoltaic generators can lead to overvoltages at the end of the network. Fig. 13(b) display the potential of BESS in reducing the overvoltages. The colored lines represent the voltage profiles with the activation of the BESS system targeting the overvoltage reduction. The different colors indicate the different positions of the energy storage in the network. For each case, the node where the BESS is located is highlighted with a star. The number is assigned according to Fig. 12. The influence of the energy storage location on voltage regulation can also be seen in Fig. 13, the green case shows a better overvoltage reduction, nonetheless

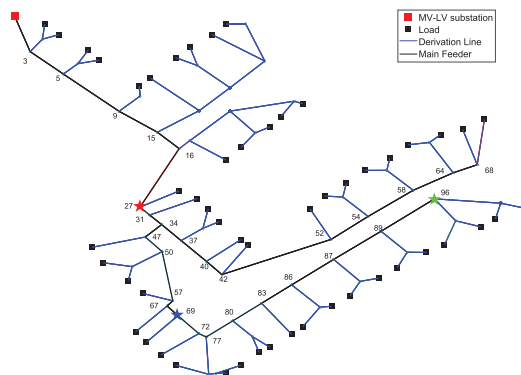

FIGURE 12. IEEE European Test Feeder schematic [69]—highlighted with a star the three nodes considered for locating the energy storage units in the analysis of Fig. 13.

storage systems present a good potential for voltage regulation.

To limit the impact on the grid's voltage of DGs, besides the introduction of voltage regulating devices in the DSOs voltage control strategies, national and international energy regulators have introduced in the grid codes the obligation for DGs connected to the distribution grids of following $Q(V)$ or $\cos \varphi(V)$ droop curves. In the most recent versions of the national technical standards, these requirements have also been extended to energy storage systems, e.g. in the Italian standards CEI 0-16 [74] and CEI 0-21 [75] and in the German standards VDE-AR-N 4110 [76] and VDE-AR-N 4105 [77]. This service has to be provided automatically and in parallel to the main functionality. It helps to mitigate the overvoltage, through the absorption of reactive power, and the undervoltage, through the injection of reactive power, in distribution network feeders.

C. PEAK SHAVING AND LOAD SMOOTHING

Peak shaving and load smoothing consist of flattening the generation and load profiles so that the maximum power seen by the grid is reduced. In real-time operation, this scheme can allow the solution of network congestion, relieving the overloading of the conductors due to generation and load peak power. Moreover, in a planning horizon, network reinforcements, such as feeder re-conducting or substituting a transformer, might be avoided and deferred in time through the installation of energy storage systems [84], [85]. In this application, energy storage might be a promising solution, since DSOs are required to guarantee the adequacy of the network infrastructure so that the network can accommodate both the nominal power of the load and of the connected generators. In addition to the upgrade deferral, peak shaving and load smoothing may have a beneficial impact on network losses. In this regard, increasing the profile matching between load and local generation, BESS operation can further reduce system losses [86], [87].

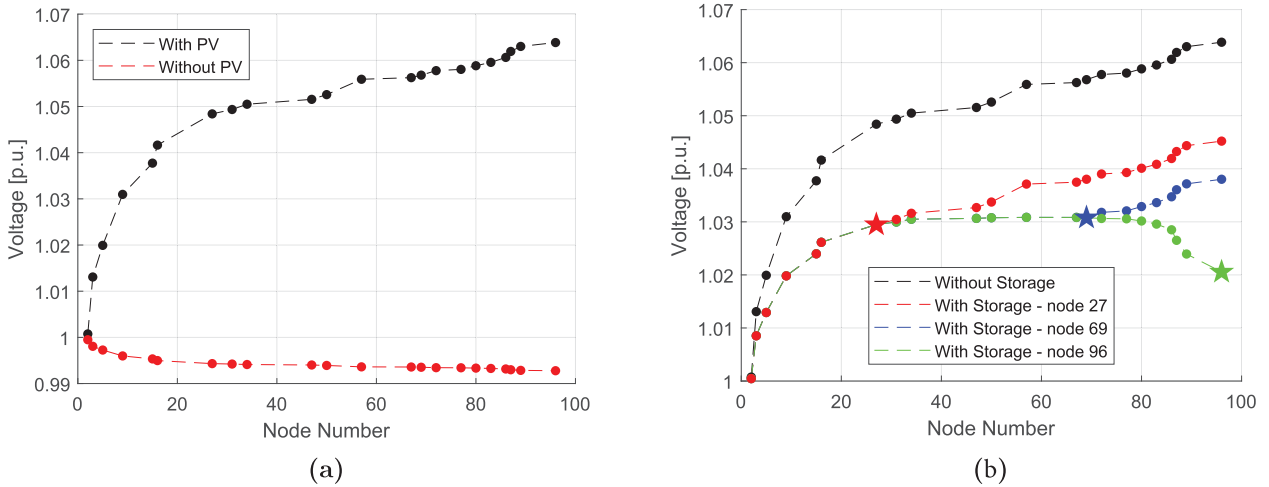

FIGURE 13. Voltage Profiles along the network: (a) with and without PV generation and (b) with PV generation and with storage units used to reduce the over voltage, the storage units are located in the node marked with a star—the nodes numbers are referred to the numeration of Fig. 12.

TABLE II Primary Control Parameters in Some European Countries—Data Obtained From [78]–[83]

Parameter	DE	FR	ES	NL	BE	GB
Full Availability	$\leq 30s$	$\leq 30s$	$\leq 30s$	$\leq 30s$	$\leq 30s$	$\leq 30s$
Droop	-	3-6 %	$\leq 7.5\%$	10%	-	3-5%
Dead Band	10 mHz	10mHz	-	-	10mHz	15mHz
Full Deployment	± 200 mHz	± 200 mHz	± 200 mHz	± 200 mHz	± 200 mHz	± 200 mHz
Service Procurement	Tenders	Bilateral contracts	Not remunerated	Tenders	Tenders	Tenders

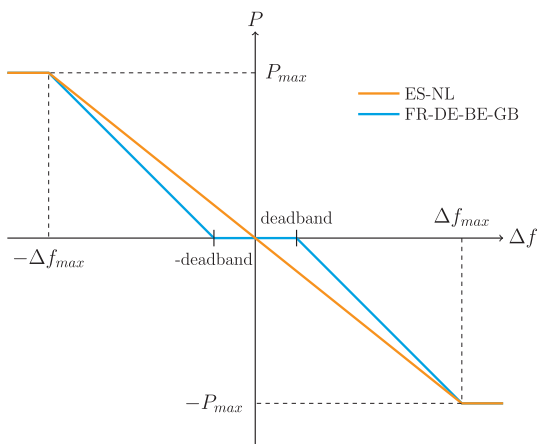

FIGURE 14. Example of P-f curves for primary frequency control—the curves are made according to the data of Table 2.

D. FREQUENCY CONTROL

Frequency control is a commercial service typically offered by generators connected to the transmission networks in the ancillary service market. In recent years, also generators and energy storage systems connected at the distribution network have been allowed to provide this service. Generators and

BESS adopt a droop control that follows the frequency unbalances and reacts accordingly, changing the power output. An example of the droop control logic is shown in Fig. 14. In Table 2, the main parameters defining the primary frequency control logic for some European countries are shown. The provision of frequency control has been proven a profitable functionality for energy storage systems [88], [89]. Energy storage systems might be limited by their maximum and minimum State of Charge (SoC), to mitigate this problem, several techniques for controlling the SoC have been proposed [90]. Depending on the country, the droop logic is implemented with different parameters, defining or not the deadband and varying the droop value. The remuneration scheme is often through tenders, where the participants bids couples of regulating power and the required price.

E. ENERGY ARBITRAGE

Energy arbitrage consists of buying and selling energy in the spot energy market. Since the electricity sector in most countries is unbundled, only a commercial user is allowed to perform energy arbitrage. This can be performed by a couple BESS+DG or BESS+load, where the storage unit is used to shift the energy production or generation to profit the most from the price variations of the energy market [91]. Business

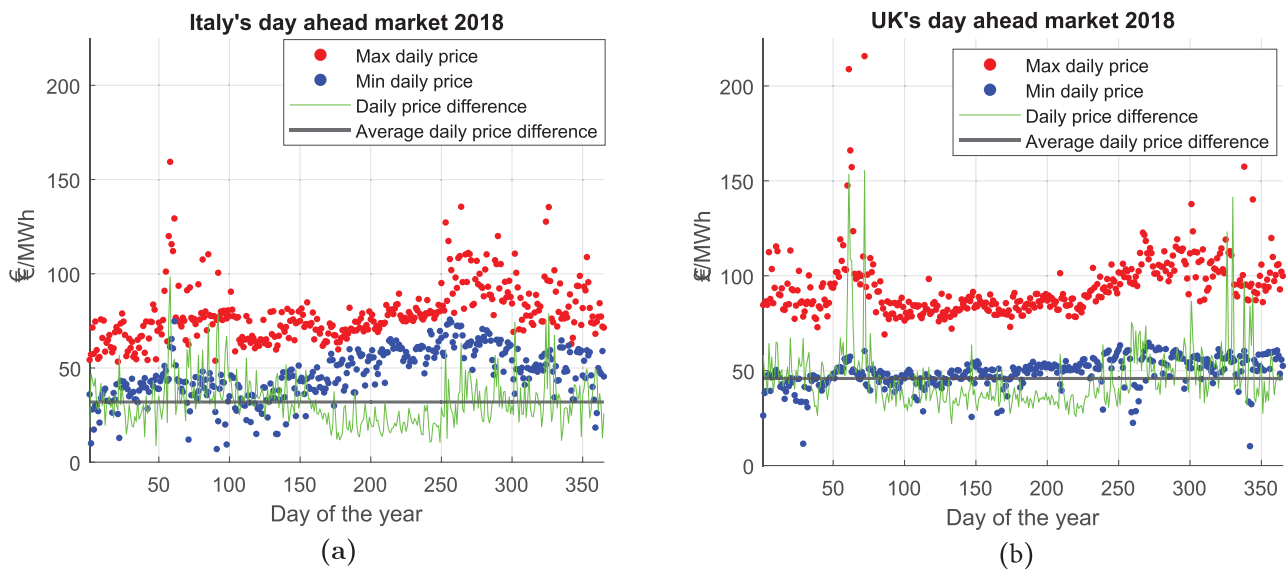

FIGURE 15. Analysis of day ahead market prices of year 2018 for Italy (a) and the UK (b). Elaboration of the author's from data obtained from [93] - [94].

cases could be built out of energy arbitrage, however present central European spot market prices might be not high enough if only energy arbitrage is considered as revenue stream [92]. Considering the Day-Ahead-Market (DAM) price data of the year 2018 for Italy and the UK, the minimum and maximum daily prices are extracted [93], [94]. These are plotted in Fig. 15, together with the daily maximum price difference and its average over the year. It is possible to see that the daily average price difference is below 50 €/MWh. For a storage system rated 1 MWh/1MW, considering € 50 as net revenues per cycle, neglecting power losses revenue taxes and battery capacity fading, and assuming the battery lifetime as 4000 cycles and the battery capital costs as 500 €/kWh, the revenues would be significantly lower than the assumed cost, confirming the findings of [92]. Following the same assumptions, the target price for break-even within 4000 cycles would be 125 €/MWh, a too high price for the present market, while 10000 cycles would be required to reach the break even for 50 €/MWh.

F. DISCUSSION

Although ESS grid applications have been so far presented individually, several studies in the literature analyze ESS performances when multiple functionalities are selected. Multifunctional BESSs can be subject to contrasting technical requirements and regulatory position, due to the combination of the different services. Moreover, the minimum power for the eligibility on the provision of specific services, for example, frequency regulation, could be too high, especially for units connected at the low voltage network. The synergies and contrasts between the different applications have been explored and the overall revenue increase, with respect to the provision of the single service separately, has been proven [95]–[98].

Future research might address how to efficiently combine multiple services, from the technical, economic, and regulatory point of view. Research should be oriented on showing how to successfully exploit at maximum the battery characteristics through designing a coherent scheme for services provision. Also, it is found that through the involvement of several stakeholders, the chances for a positive business case increase.

IV. BESS SIZING AND LOCATION IN DISTRIBUTION NETWORK

The problem of the optimal sizing and siting of storage systems in the distribution network has been widely studied in the literature [6], [16]–[18]. Several variables need to be defined to approach it, the solving technique, the performance metric for the optimum evaluation, the battery technology and modeling, and the test network where to perform the studies. There are two main approaches to this problem: mathematical programming and heuristic methods. The distinctions between the two consist in how to set the optimization problem and in the solving algorithm. Other approaches, such as analytical methods, can perform well in small networks, but they are not suitable or too computational demanding in complex scenarios [16], [17].

Mathematical programming consists in describing the problem with a set of equations, and, according to the characteristics of these, different solving techniques can be applied. Some conventional formulations are Linear Problem, Semi Definite Problem, or Second Order Cone Problem. Many commercially available solvers can solve convex optimization problem, and these have been widely used in power systems applications with good computational performances. Mathematical programming requires an explicit analytical

TABLE III Mathematical Programming vs Heuristic Methods

	Mathematical Programming	Heuristic methods
Pros	<ul style="list-style-type: none"> • Strong in finding global optimum • Mature in power systems • Good computational performances 	<ul style="list-style-type: none"> • Flexible to solve all problems • Avoid complex derivations • Less computationally demanding
Cons	<ul style="list-style-type: none"> • Convergence difficulties • Explicit mathematical formulation required 	<ul style="list-style-type: none"> • May converge to local optimum • Less accuracy

formulation of the objective function and the constraints. Heuristic methods do not require explicit mathematical formulations and, for this reason, they are suitable for multi-objective optimization. The general pattern in applying these algorithms consists of adopting artificial intelligence methods for the size and location of the storage systems and then evaluating the fitness of the candidates through classic optimal power flow algorithms. Heuristic methods found several derivations, however, some of the most common algorithms are Particle Swarm Optimization (PSO) [99] and Genetic Algorithms (GA) [100]. PSO has been adopted to solve some of the classical power system problems, for example, load flow, voltage control, and economic dispatch [101]. Due to the nature of the energy storage sizing and placement problem, PSO and GA are valid candidates as an optimization algorithm. Table 3 shows a brief comparison between the two categories of optimization techniques. As previously discussed, when convex programs are adopted, an explicit formulation of the problem is required. In this aspect, heuristic methods are more flexible at the expense of the accuracy of the solution. These algorithms do not ensure reaching the global optimum, and they may get trapped in a local optimum.

An overview of some relevant studies regarding the planning of the distribution system, including energy storage, is provided in Table 4. This review aims at understanding how the problem of sizing and siting storage systems has been tackled in the literature and at highlighting the assumptions adopted in the problem settings. Through this information it might be possible to reveal the limitations of the studies analyzed and the potential improvements with respect to state of the art. Table 4 clearly shows that the energy storage planning problem has been widely considered both through mathematical programming, where storage is placed targeting the optimization of virtual operation costs [114], of the energy purchase costs [115], and of system costs, losses and the energy flow at the substation [106], and through artificial intelligence based algorithms. Heuristic methods have been adopted for evaluating the optimal storage capacity, for minimizing losses and voltage violations after finding the best location through loss sensitivity analysis (PSO) [116], for solving the grid expansion plan aiming at lowering the total system costs (PSO) [117] (GA) [118], for minimizing storage capital costs, where BESS are used to mitigate overvoltages (GA) [119] and for avoiding network congestion (PSO) [104]. Hybrid approaches, combining heuristic methods and convex programs, have been used for the minimization of the VAR power flow

at the HV/MV substation (GA+SQP) [111], for maximizing revenues from arbitrage, upgrade deferral, improving in system reliability and losses reduction (GA+LP) [105] and for optimizing system costs and revenues from arbitrage, environmental emission reduction, transmission access fee and loss reduction (GA+LP) [108]. The last study couples DIGSILENT PowerFactory and MATLAB, the first for the network models and the second for the optimization algorithms. From the literature, it is found that a few articles base their analysis only on technical parameters. The main trend, in fact, consists of targeting the minimization of system costs on a long term horizon. This can be explained by the need to justify the high initial investment of storage units not only through technical improvements of the grid but also with a feasible business plan. Technical parameters, such as branch current, node voltages and the generators and BESS capability curves, are included in most relevant studies under the form of constraints of the problem. Furthermore, several studies introduce also constraints in the short term power fluctuations. In this respect BESS are adopted to mitigate the power swing of the associated renewable energy based generator to comply to the eventual TSOs or DSOs requests, as detailed in Section III-A [61]–[63]. In addition, it is found that mostly, as simplification, the planning problem is considered in a discrete way [111], in the sense that the sizing of the storage is considered by steps of 10 or 100 kWh, or in sequential approach [113], [114], first, the optimal location is found, and secondly, the battery capacity is evaluated. These strategies might simplify the setting of the problem at the expense of the solution’s accuracy. Another interesting approach for the deployment of several storage units consists of dividing the network into different clusters and finding the optimal location of the units within each cluster [112]. Several electrochemical technologies have been considered, for instance, lithium-ion, vanadium redox, NaS, and lead-acid, yet, in most cases, the differences in the modeling are accounted for in terms of capital cost, lifetime and round trip efficiency. Modeling battery efficiency as fixed value is a common practice [103], [105], [107], [108], [110], [111], [113], [115]. More accurate solutions, such as electrical models, are rarely taken into account at the planning phase, although a too simplified model can lead to significant errors in the lifetime and aging estimation [120]. In [121] the energy storage planning and scheduling optimization routine is run both using an accurate BESS description, equivalent electrical circuit, and a simplified one. The study shows that when the simplified model is used the BESS lifetime is negatively

TABLE IV. Energy Storage Systems Sizing and Location Studies.

Main objective	Secondary Objective	Problem	Analysis	Opt technique	ESS technology	ESS model	Test grid	RES included	Reference
Power quality and reliability	Equipment costs (CAPEX of BESS and switches)	Sizing and siting	Technical and Economical	NSGA and Pareto dominance	Not specified	Not specified	Portuguese radial feeder	No	[102]
DG curtailment minimization	Congestion and voltage management	Sizing	Technical	Multi period AC OPF	Li-ion	85% Fixed efficiency	English MV network	Wind	[103]
Congestion management	Minimize ESS costs	Pre determined siting + discrete sizing	Economical	PSO	Not specified	Not specified	IEEE 24-bus / transmission	PV + Wind	[104]
System costs	System upgrade, losses, arbitrage and interruption	Siting + discrete sizing	Economical	GA and LP + Monte Carlo analysis for the probabilistic approach	LA, NaS, VR	Fixed efficiency	33-bus radial	Wind	[105]
	Active power flow at primary substation	Sizing and siting	Economical	SOCP OPF	Lead acid	Not specified	69-bus 12.66kV	PV	[106]
	Arbitrage, peak shaving, reverse flow	Pre determined siting + sizing	Economical (NPV)	Stochastic optimization	NaS	81% Fixed efficiency	Modified IEEE 13-bus	PV	[107]
	Arbitrage, environmental emissions, transmission access fee and losses	Sizing + siting	Economical (NPV)	GA combined with LP	VRB	75% Fixed efficiency	Iranian LV grid	PV	[108]
System upgrade deferral	Voltage control, losses and congestion management	Sizing and siting	Economical	SOCP and ADMM	Li ion	Losses quadratic with power	287-bus Swiss network	PV	[109]
	Voltage control	Sizing + siting	Economical	LP and statistic modelling of random parameters	Li-ion	Fixed efficiency	IEEE 13-bus balanced	PV	[110]
	Arbitrage, Var power flow and incentives	Discrete sizing + siting	Economical (NPV)	GA and SQP	Redox Flow	72% Fixed efficiency	17-bus MV	PV + Wind	[111]
Voltage improvement	Losses and storage size	First siting then sizing	Technical for siting and Economical for sizing	CSA and SDP	Not specified	Not specified	Italian LV 17-bus, IEEE 34-bus and 200 random grids	PV	[112]
Losses minimization	Investment costs	First siting then sizing	Technical	Siting = losses sensitivity analysis / Sizing = Pattern search (PS) / (OPF = Backward/Forward Sweep Method (BFSM) + MIQCQP)	Li-ion	95 % Fixed efficiency	CIGRE 14-bus MV and 17-bus sub transmission grid	No	[113]
Min virtual op costs	Voltage, feeder current, losses, energy cost and load curtailment	Sizing and siting	Technical and Economical	MI SOCP	Not specified	Losses quadratic with power	Modified IEEE 34-bus	PV + Wind	[114]
Minimize energy purchase costs	BESS lifetime	Siting	Economical	MI SOCP	Lead acid	81 % Fixed efficiency	11-bus system	PV + Wind	[115]

NPV = Net Present Value, NSGA = Non-dominated Sorting Genetic Algorithms, OPF = Optimal Power Flow, SOCP = Second Order Cone Program, ADMM = Alternating Direction Method of Multipliers, SQP = Sequential Quadratic Program, SDP = Semi Definite Program, CSA = Clustering and Sensitivity Analysis, MI SOCP = Mixed Integer SOCP

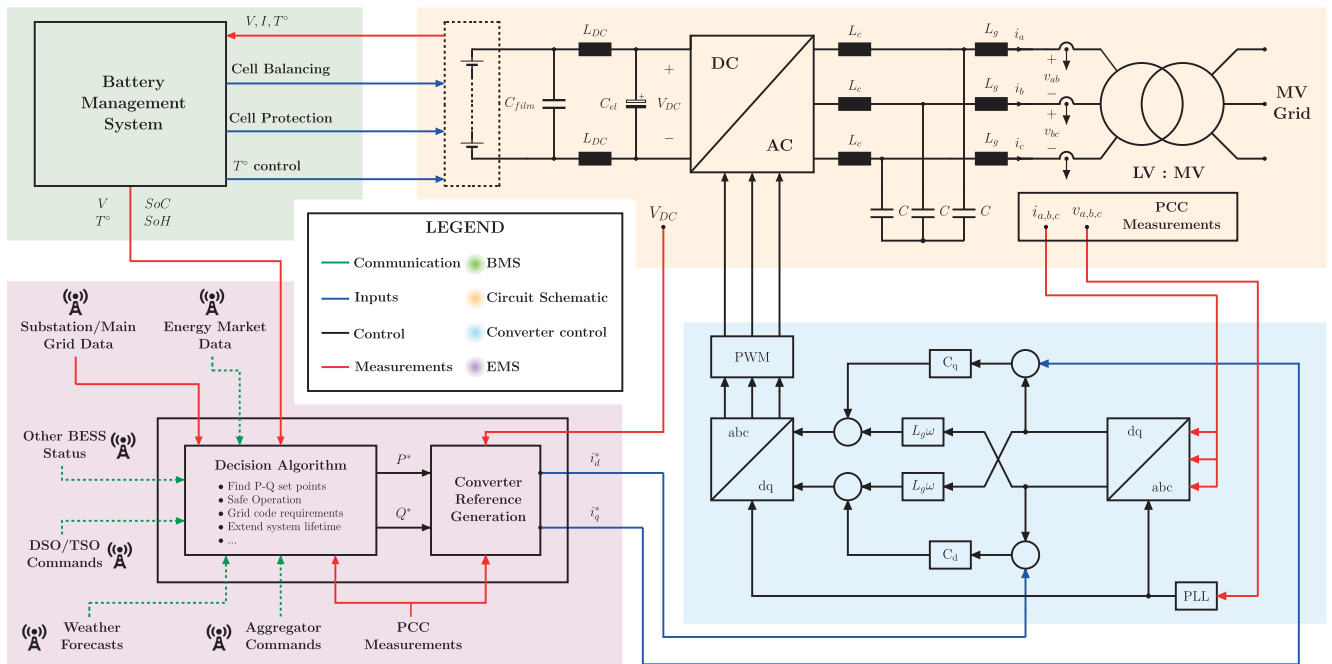

FIGURE 16. Battery energy storage system circuit schematic and main components.

influenced by a non-optimal BESS scheduling. However, in the case presented, the computational time significantly increase, remaining nonetheless acceptable.

At the planning stage, the focus of the researches is on deploying ESSs for mitigating the impact of RES generation whereas providing a cheap solution for upgrading the network. In this aspect, to improve the accuracy of the analysis, future research should consider more detailed battery models, such as considering variable efficiency or equivalent electrical circuits, since battery modelling is not adequately addressed in most of the planning studies, both in terms of performances and lifetime. These strongly depend on the BESS operating conditions, rarely taken into account at the planning phase [122], [123]. Also, since the electricity sector is undergoing profound changes, properly considering the future evolution of distribution networks, in terms of load and generation increase as well as the introduction of new types of loads, can provide a clear understanding of the role of energy storage.

V. BESS MANAGEMENT AND OPERATION

The main components necessary for the functioning of a battery energy storage system are illustrated in Fig. 16. The Battery Management System (BMS) collects measurements data from the electrochemical storage and it is responsible for balancing the cells' voltage, protecting them from overloading, and for minimizing the temperature gradient to guarantee an even ageing of the cells [124]. The BMS computes the state of charge and the state of health of the battery, feeding this information to the Energy Management System (EMS),

i.e., the unit in charge of the storage system operations and protection. The EMS, as shown in Fig. 16, in addition to the battery parameters received from the BMS, it collects inputs from different sources, e.g., when available, electrical measurements at the Point of Common Coupling (PCC), weather forecasts, energy market data, and commands from DSOs, TSOs and aggregators. Given these data, the decision algorithm embedded in the EMS finds the P-Q set points of the storage systems [125]. These are digitally converted into the reference values for the DC-AC converter and sent to the control board that drives the system. In Fig. 16, the block with light blue background illustrates a current control scheme based on the dq frame for the storage system [126]. Additionally, the EMS is responsible for scheduling BESS operation and, when multiple BESSs are present, for coordinating the different storage units. Each BESS unit may be equipped by an independent EMS, managing the storage system based on local measurements, as depicted in Fig. 17(a), alternatively, there may be a supervisory unit managing a portion of the grid, Fig. 17(b), or the full network Fig. 17(c), or each unit equipped with a decision making algorithm able to communicate with the neighbouring units Fig. 17(d). These management strategies may be classified as Local, Decentralized, Centralized, and Distributed control [71].

The main challenges when designing a control system for battery storage systems consist of the communication infrastructure, developing the decision-making algorithm, and managing the uncertainties in the data and the errors in the forecasts. The communication infrastructure can be costly, especially in geographically vast grids. Moreover, for an

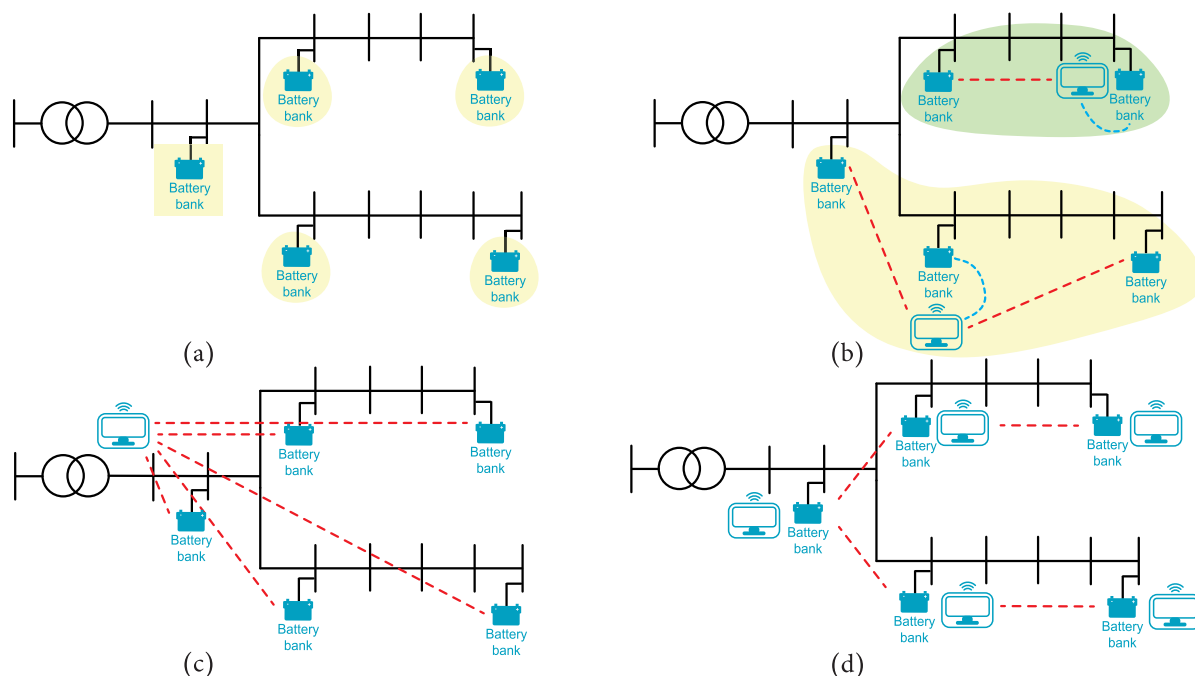

FIGURE 17. Example of BESS management strategies: a) Local control, b) Decentralized control, c) Centralized control, and d) Distributed control.

effective control strategy, the requirements in terms of reliability, latency, and data rate might be stringent.

In Table 5, a summary of some selected papers that study the BESSs' optimal control and operation is presented. What it is possible to notice at first sight from the table is that most studies consider the DSO as controlling agent of the storage units. Mostly, the articles' focus is on mitigating the impact of PVs, and the approach developed is tailored for DSOs [127]–[131] or to be applied locally by the single devices [131]–[134]. However, regarding the control strategy, there is not a solution that emerges as the most common. Photovoltaic panels are generally considered in the network, and so BESS are often studied for reducing the overvoltages created by the PV generators. The studies presented in Table 5 are related to both medium and low voltage distribution grids. Despite sharing similar problems, the two voltage levels have different degrees of monitoring and automation. These peculiarities need to be considered when designing the control system of storage devices in order to optimally exploit the already available resources and to minimize the extra costs for the integration of new systems.

The most frequently considered ESS technologies are Li-ion [132]–[135] or lead-acid [127], [137], [138], besides, electrical models are also widely used [129], [131]–[133], [135]. The common adoption of electrical models shows a difference from what is found in the analysis of the planning stage studies of Table 4, where simpler solutions are preferred. In [121] the energy storage planning and scheduling optimization routine is run both using an accurate BESS description, through an equivalent electrical circuit, and neglecting the accurate

model for the storage system. The study shows that when the accurate model is neglected the BESS lifetime is negatively influenced by a non-optimal BESS scheduling. This article shows the importance of an accurate BESS description in the operation optimization for extending the storage lifetime.

Regarding the data available for the decision algorithm, it is possible to see that in most of the analyzed cases, the control algorithm relies on local electrical measurements. Moreover, some studies consider also weather conditions [130]. Articles [139], [140] consider a fully monitored network for coordinated or centralized control. However, this might be not cost-effective or easy to realize, especially at the LV level, due to the high number of LV networks and their low degree of automation and monitoring devices. In other studies, a limited amount of network measurements are fed to a state estimator [129], [135]. The second solution, although more computationally expensive and complex to design, offers a solution more compatible with the state of the art of distribution grids. Another interesting insight coming from the literature is that when distributed control is applied the different units share their State of Charge to properly share the required regulating power [134].

As previously discussed, the EMS is responsible for the scheduling of the storage systems. Energy market data, RES plant production and grid parameters, such as node voltage and branch current, are only partly predictable. In this context, the scheduling algorithm, based on available data, historical data and forecasts, is in charge of defining the BESS operation for a fixed horizon. However, real time data and more accurate forecasts can be obtained during operation and this

TABLE V. Energy Storage Systems Management and Operation Studies.

Main service	Extra services	Controller	Control input	ESS control	ESS technology	ESS model	Test grid	RES included	Reference
Voltage control	No	DSO	Local voltage, remaining battery life, SoC and voltage sensitivities	Non coordinated / Coordinated	VRLA	Fixed efficiency	Residential UK grid	PV	[127]
	No	DSO ESS / Local PV	Short term forecast of load and PV sensitivities	Centralized	Not specified	Not specified	23-bus LV danish	PV	[128]
	Voltage and frequency control	Main control center	Voltage, current, frequency and SoC	Coordinated + main control center	Li-ion	Electrical model	MV Korean	No	[133]
	No	Local	Voltage and SoC	Local	Li-ion	Electrical model	Real German grid	PV	[132]
	No	DSO	State estimator fed by real time measurement	Centralized	General electrochemical + super capacitor	Electrical model	Mod. IEEE 34-bus	PV	[129]
	No	Local / Distributed	Local voltage and SoC of BESSs	Coordinated	Li-ion	Linear efficiency	Realistic 7-bus LV	PV	[134]
	Losses minimization	DSO	Irradiation, $T^{\circ}C$, substation measures and historic data of load and DG	Receding horizon control	Not specified	Varying efficiency	Italian LV 17-buses	PV	[130]
	No	Local / Distributed	Local voltage and SoC	Distributed + localized	VRB	Electrical model	6-bus LV/ 13-bus LV	PV	[131]
	Active power dispatch	DSO	Power and voltage or state estimation	Model predictive control	Li-ion	Electrical model	IEEE 34-nodes MV and CIGRE benchmark LV grid	PV	[135]
	No	DSO	State of load, generator, ESS and OLTC	Fully monitored network	Li-ion	Fixed efficiency	English MV	Wind	[103]
Frequency control	Voltage and frequency control	Main control center	Voltage, current, frequency and SoC	Coordinated + main control center	Li-ion	Electrical model	MV Korean	No	[133]
Power profile flattening	No	DSO / Local	Predictions of load and generation and network topology	Centralized / Decentralized / Distributed	Not specified	Not specified	Small residential network	PV	[136]
Optimal Day Ahead bidding	No	DSO	Historical data, ESS and topology	Centralized	Lead acid	Fixed efficiency	IEEE 15-bus 11kV	PV + Wind	[137]
Power quality	Voltage control	Local	Local Voltage	Local	Lead acid + Ultra capacitor	Not specified	16-bus network LV	PV	[138]
Minimize energy costs	Local energy balancing	DSO	Fully monitored network	SOQP	Not specified	Not specified	13-bus CIGRE	PV + Wind	[139]
	No	DSO	Full awareness considered	MI SOCP	Not specified	Fixed efficiency	11-bus and 42-bus	PV + Wind	[140]
Local energy balancing	Power quality	DSO	Fully monitored network	SOQP	Not specified	Not specified	13-bus CIGRE	PV + Wind	[139]
Active power dispatch	Voltage control	DSO	Power and voltage or state estimation	Model predictive control	Li-ion	Electrical model	IEEE 34-nodes MV and CIGRE benchmark LV grid	PV	[135]
	Peak shaving	DSO	Reference SoC and day ahead profile	Model predictive control	Not specified	Not specified	12 kV grid	PV	[141]

VRLA = Valve Regulated Lead Acid, MI SOCP = Mixed Integer Second order Cone Program, SOQP = Sequential Quadratic Programming, OLTC = On-Load Tap Changer, SoC = State of Charge, T = Temperature, DG= Distributed Generators.



FIGURE 18. Example of a Li-ion based battery energy storage system rated up to 3.1 MW/MWh [143].

might change the optimal storage scheduling. Model Predictive Control is a well established technique used for dealing with uncertainties and forecasts in multi period optimization and it has also been applied for the scheduling of energy storage systems operations [130], [135], [141], [142].

For future research, it is worth to properly take into account robustness against uncertainty and forecasts errors, e.g., through Model Predictive Control. Especially when centralized control strategies are adopted, a state estimation algorithm might be necessary to create an accurate overview of the network. As expected local control offers the poorest performances; however, in particular situations, it may be an appropriate solution. Distributed or coordinated control is the trade-off that allows higher flexibility to distributed storage systems and might be the most efficient solution for future applications. Future research should aim at developing control strategies that fulfil the targeted objective, but at the same time, take into account the reality of distribution networks and of the communication infrastructure.

VI. ENERGY STORAGE SYSTEMS INSTALLATIONS

Energy storage systems are usually designed and commercialized by an Energy Storage Systems Integrator (ESSI). ESSIs buy or internally manufacture the battery packs, the power conditioning system, the auxiliary system, and the controlling software. These are then assembled inside the containers. They offer modular BESS solutions, in terms of power and energy ratings, ranging from hundreds of kW to few MW. An example of the final ESS product is displayed in Fig. 18. ESSIs play a crucial role in the proliferation of energy storage systems, striving for an optimized product and seeking for new applications and use cases. Navigant Research, a market research and advisory firm in the field of the energy industry, identifies Fluence, Nidec ASI, Tesla, RES, Powin Energy, Greensmith, LG CNS, NEC Energy Solutions, NextEra Energy Resources, and Doosan GridTech as main players in the utility scale ESSI market [145], [146]. Other Energy Storage Systems Integrators are, for instance, ABB, Alfen, General Electric, and Schneider Electric. Concerning the battery cell manufacturing, some of the main players in the market today are, for lithium-ion based technologies: A123Systems,

CATL, ElectroVaya, Fiamm, Johnson Control, LG, Panasonic, Saft, Samsung, and Toshiba; for Flow Batteries: Cell-Cube, Primus Power, Rongke Power, UniEnergy Technologies, and Vionx Energy; and for Sodium Sulfur batteries NGK Insulators.

Regarding BESS installations and pilot projects, the database on energy storage installations maintained by National Technology & Engineering Sciences of Sandia, LLC (NTESS), operator of Sandia National Laboratories for the U.S. Department of Energy/National Nuclear Security Administration [144], contains information, such as power and energy rating, location, applications, owner, storage technology, and status, of installations located worldwide. To adhere to the review's focus, only the active installations, with sufficient information, adopting electrochemical technology and power rating less or equal to 5 MW are considered. At the time of consultation, this resulted in a set of 466 projects. The selected projects are analyzed to extract the services performed by the storage and the electrochemical technology, the two pie charts of Fig. 19 display this. What stands out from Fig. 19(a) is the fact that there is not a single use case that predominates the BESS application. Additionally, six services, electric bill management, energy time shifting, frequency regulation, microgrid capability, renewable generation shifting, and renewable capacity firming, are the most frequent BESS use cases. On the other hand, Fig. 19(b) clearly shows how lithium-ion technologies are by far the most common solution. Fig. 20 shows that BESS are often deployed as multi-functional and that they are mostly involved in both commercial and technical services, in line with what was discussed in Section III.

Besides general information regarding battery based storage projects, a closer look in a specific project where BESS were tested for frequency control is given. In this context, TenneT B.V., Dutch TSO, conducted a pilot project regarding the provision of Frequency Containment Reserves (FCR) through aggregators of different sources, including energy storage [147]. During the pilot, several aggregated pools have been tested for the provision of FCR in the Dutch market. Between the several aggregator pools also lead-acid and lithium-ion batteries have been tested. The minimum bid size was reduced from 1 MW to 100 kW, and the participants were required to submit their bids each week for the following week. Batteries' performance has shown to be strongly dependent on the battery management system, on the other hand, the energy limitation of the energy storage did not hamper the FCR provision. The main result of the pilot shows that all assets were technically able to provide FCR and that the main difficulties were related to the frequency measurement and the communication infrastructure between the TSO and the aggregators. It is shown that TSO's requirements in terms of minimum power step might be challenging for BESSs. The reduction of the bidding period and the measuring requirements have been identified as main points for easing aggregators' participation in the FCR market.

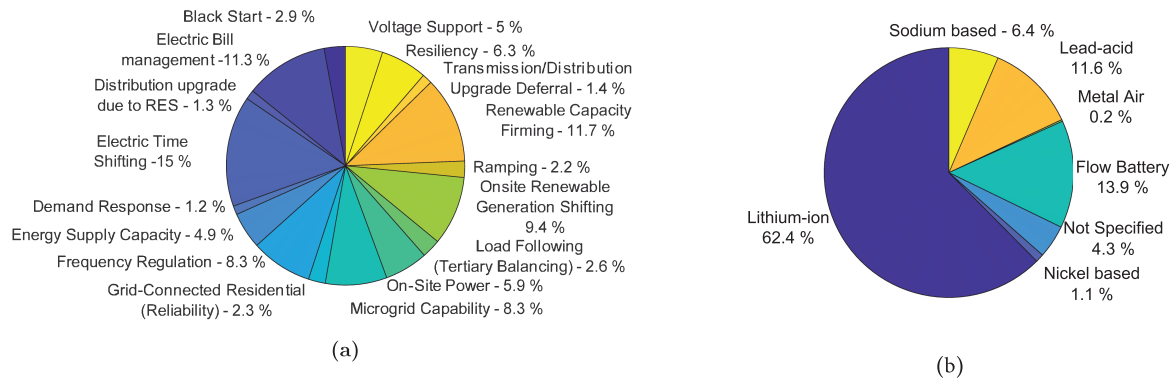

FIGURE 19. Storage application (a) and technologies (b) – author’s elaboration from [144].

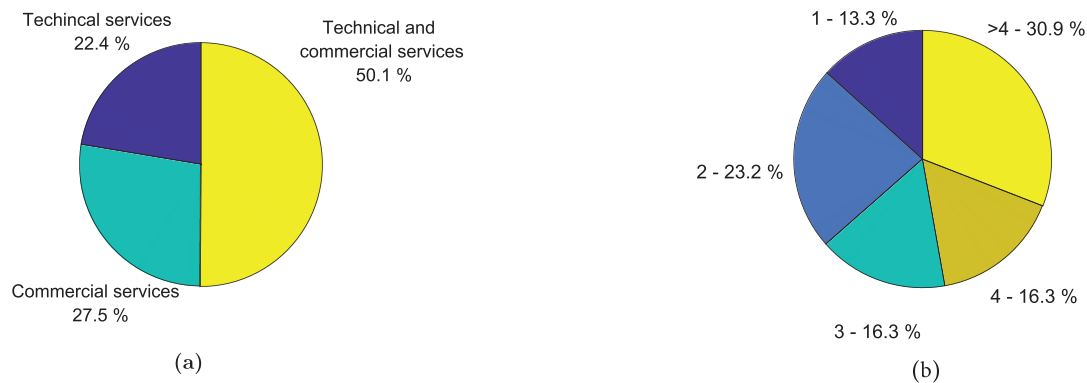

FIGURE 20. Percentage of BESS installation performing technical and commercial services (a) and number of services that each installation performs (b) - author’s elaboration from [144].

VII. CONCLUSION

This paper has focused on the different aspects of the integration of energy storage systems in distribution networks. It has been shown that the storage system has the potential to strengthen and improve the electrical grid in several aspects. Nevertheless, energy storage systems are struggling to achieve mass deployment. From the review of the literature, some key challenges that demand further investigation, so that both technical and economic performances of battery storage systems can be enhanced, have been highlighted.

- **DC-AC energy storage converter design considering more advanced circuit technologies and BESS functionality.** The literature related to the converter design shows that Two Level VSCs, mostly adopted in commercial products, could be outperformed by Three Level and modular converters, in terms of efficiency, reliability, power density and costs. Nonetheless, three level and multilevel topologies have been widely studied for other applications, it has not been shown how the adoption of a more performing converter topology influences the storage system technical performances and its cost of ownership. Furthermore, it is found that few studies rightly consider the peculiarity of electrochemical storage and the difference in the operating conditions according to the grid application for the DC-AC converter design.

- **Study the provision of multiple grid services from the technical and regulatory point of view.** The high initial investment and the unclear revenue streams are the main barriers for the BESS deployment. In this respect, it is found that the combination of various services can enhance BESS profitability. This is confirmed by the analysis of Section VI, where it is pointed out that the majority of running installations perform multiple services and often target both technical, e.g., voltage regulation, network upgrade deferral, microgrid capabilities, and black start, and market related activities, such as energy arbitrage, frequency regulation, and demand response. Nonetheless, these can lead to contrasting technical and regulatory requirements. Further research is then necessary on how to optimally integrate the provision of multiple services from the same storage unit.
- **Accurate and computationally performing battery models.** Studies have proved that a too simplified battery model can lead to excessive capacity fading due to non-optimal scheduling. The usage of detailed models comes at the price of computational performances. Further research should then be focused on developing models that precisely describe the battery performance and lifetime, but at the same time do not overly rise the computational time. In this way, these may be applied not

only for the short term scheduling but also for network planning.

REFERENCES

- [1] K. Clement, E. Haesen, and J. Driesen, "Stochastic analysis of the impact of plug-in hybrid electric vehicles on the distribution grid," in *Proc. CIRED 20th Int. Conf. Exhib. Electric. Distribution - Part 2*, 2009, pp. 1–4.
- [2] R. A. Walling, R. Saint, R. C. Dugan, J. Burke, and L. A. Kojovic, "Summary of distributed resources impact on power delivery systems," *IEEE Trans. Power Del.*, vol. 23, no. 3, pp. 1636–1644, Jul. 2008.
- [3] J. Delgado, R. Faria, P. Moura, and A. T. de Almeida, "Impacts of plug-in electric vehicles in the portuguese electrical grid," *Transp. Res. Part D Transport Environ.*, vol. 62, pp. 372–385, Jul. 2018.
- [4] L. F. Ochoa, A. Padilha-Feltrin, and G. P. Harrison, "Evaluating distributed generation impacts with a multiobjective index," *IEEE Trans. Power Del.*, vol. 21, no. 3, pp. 1452–1458, Jul. 2006.
- [5] A. Canova, L. Giaccone, F. Spertino, and M. Tartaglia, "Electrical impact of photovoltaic plant in distributed network," *IEEE Trans. Ind. Appl.*, vol. 45, no. 1, pp. 341–347, Jan./Feb. 2009.
- [6] C. K. Das, O. Bass, G. Kothapalli, T. S. Mahmoud, and D. Habibi, "Overview of energy storage systems in distribution networks: Placement, sizing, operation, and power quality," *Renewable Sustain. Energy Rev.*, vol. 91, pp. 1205–1230, Aug. 2018.
- [7] G. Castagneto Gisse, P. E. Dodds, and J. Radcliffe, "Market and regulatory barriers to electrical energy storage innovation," *Renewable Sustain. Energy Rev.*, vol. 82, pp. 781–790, Feb. 2018.
- [8] S. Mir Mohammadi Kooshknow and C. Davis, "Business models design space for electricity storage systems: Case study of the Netherlands," *J. Energy Storage*, vol. 20, pp. 590–604, Dec. 2018.
- [9] K. K. Zame, C. A. Brehm, A. T. Nitica, C. L. Richard, and G. D. Schweitzer, "Smart grid and energy storage: Policy recommendations," *Renewable Sustain. Energy Rev.*, vol. 82, pp. 1646–1654, Feb. 2018.
- [10] G. Zubi, R. Dufo-López, M. Carvalho, and G. Pasaoglu, "The lithium-ion battery: State of the art and future perspectives," *Renewable Sustain. Energy Rev.*, vol. 89, pp. 292–308, Jun. 2018.
- [11] E. Telaretti and L. Dusonchet, "Stationary battery technologies in the U.S.: Development Trends and prospects," *Renewable Sustain. Energy Rev.*, vol. 75, pp. 380–392, Aug. 2017.
- [12] A. B. Gallo, J. R. Simões-moreira, H. K. M. Costa, M. M. Santos, and E. Moutinho, "Energy storage in the energy transition context: A technology review," *Renewable Sustain. Energy Rev.*, vol. 65, pp. 800–822, Nov. 2016.
- [13] S. Sabihuddin, A. E. Kiprakis, and M. Mueller, "A numerical and graphical review of energy storage technologies," *Energies*, vol. 8, no. 1, pp. 172–216, 2015.
- [14] B. Zakeri and S. Syri, "Electrical energy storage systems: A comparative life cycle cost analysis," *Renewable Sustain. Energy Rev.*, vol. 8, no. 1, pp. 172–216, 2015.
- [15] M. C. Argyrou, P. Christodoulides, and S. A. Kalogirou, "Energy storage for electricity generation and related processes: Technologies appraisal and grid scale applications," *Renewable Sustain. Energy Rev.*, vol. 94, pp. 804–821, Oct. 2018.
- [16] N. D. Hatzigiorgiouri, D. Škrlec, T. Capuder, P. S. Georgilakis, and M. Zidar, "Review of energy storage allocation in power distribution networks: Applications, methods and future research," *IET Gener. Transmiss. Distrib.*, vol. 10, no. 3, pp. 645–652, 2016.
- [17] Y. Yang, S. Bremner, C. Menictas, and M. Kay, "Battery energy storage system size determination in renewable energy systems: A review," *Renewable Sustain. Energy Rev.*, vol. 91, pp. 109–125, 2018.
- [18] H. Saboori, R. Hemmati, S. M. S. Ghiasi, and S. Dehghan, "Energy storage planning in electric power distribution networks—A state-of-the-art review," *Renewable Sustain. Energy Rev.*, vol. 79(C), pp. 1108–1121, 2017.
- [19] I. Alsaïdan, A. Alanazi, W. Gao, H. Wu, and A. Khodaei, "State-of-the-art in microgrid-integrated distributed energy storage sizing," *Energies*, vol. 10, no. 9, p. 1421, 2017.
- [20] L. A. Wong, V. K. Ramachandaramurthy, P. Taylor, J. B. Ekanayake, S. L. Walker, and S. Padmanaban, "Review on the optimal placement, sizing and control of an energy storage system in the distribution network," *J. Energy Storage*, vol. 21, pp. 489–504, 2019.
- [21] V. Fernão Pires, E. Romero-Cadaval, D. Vinnikov, I. Roasto, and J. F. Martins, "Power converter interfaces for electrochemical energy storage systems—A review," *Energy Convers. Manage.*, vol. 86, pp. 453–475, 2014.
- [22] G. Wang et al., "A review of power electronics for grid connection of utility-scale battery energy storage systems," *IEEE Trans. Sustain. Energy*, vol. 7, no. 4, pp. 1778–1790, Oct. 2016.
- [23] World Energy Council, "World energy resources 2016," Tech. Rep., London, U.K., 2016.
- [24] IRENA, *Electricity Storage and Renewables: Costs and Markets to 2030*, International Renewable Energy Agency, Abu Dhabi, 2017.
- [25] E. Chemali, M. Preindl, P. Malysz, and A. Emadi, "Electrochemical and electrostatic energy storage and management systems for electric drive vehicles: State-of-the-art review and future trends," *IEEE J. Emerg. Sel. Top. Power Electron.*, vol. 4, no. 3, pp. 1117–1134, Sep. 2016.
- [26] BloombergNEF, Mar. 5, 2019. [Online]. Available: <https://about.bnef.com/blog/behind-scenes-take-lithium-ion-battery-prices/>
- [27] BloombergNEF, Dec. 3, 2019. [Online]. Available: <https://about.bnef.com/blog/battery-pack-prices-fall-as-market-ramps-up-with-market-average-at-156-kwh-in-2019/>
- [28] X. Luo, J. Wang, M. Dooner, and J. Clarke, "Overview of current development in electrical energy storage technologies and the application potential in power system operation," *Appl. Energy*, vol. 137, pp. 511–536, Jan. 2015.
- [29] H. Chen, T. N. Cong, W. Yang, C. Tan, Y. Li, and Y. Ding, "Progress in electrical energy storage system: A critical review," *Prog. Nat. Sci.*, vol. 19, no. 3, pp. 291–312, 2009.
- [30] H. Ibrahim, A. Ilinca, and J. Perron, "Energy storage systems-Characteristics and comparisons," *Renewable Sustain. Energy Rev.*, vol. 12, no. 5, pp. 1221–1250, 2008.
- [31] I. Hadjipaschalis, A. Poullikkas, and V. Efthimiou, "Overview of current and future energy storage technologies for electric power applications," *Renewable Sustain. Energy Rev.*, vol. 13, no. 6-7, pp. 1513–1522, 2009.
- [32] Q. Liao, B. Sun, Y. Liu, J. Sun, and G. Zhou, "A techno-economic analysis on NaS battery energy storage system supporting peak shaving," *Int. J. Energy Res.*, vol. 40, pp. 241–247, 2016.
- [33] N. Kawakami et al., "Development and field experiences of stabilization system using 34MW NAS batteries for a 51MW Wind farm," in *Proc. IEEE Int. Symp. Ind. Electron.*, 2010, pp. 2371–2376.
- [34] S. Tewari and N. Mohan, "Value of NAS energy storage toward integrating wind: Results from the wind to battery project," *IEEE Trans. Power Syst.*, vol. 28, no. 1, pp. 532–541, Feb. 2013.
- [35] L. N. Thaller, "Electrically rechargeable redox flow cells," in *Proc. 9th Intersociety Energy Convers. Eng. Conf.*, 1974, pp. 1–5.
- [36] P. Leung et al., "Recent developments in organic redox flow batteries: A critical review," *J. Power Sources*, vol. 360, pp. 243–283, 2017.
- [37] C. Ponce de León, A. Frías-Ferrer, J. González-García, D. A. Szánto, and F. C. Walsh, "Redox flow cells for energy conversion," *J. Power Sources*, vol. 160, no. 1, pp. 716–732, 2006.
- [38] P. Leung, X. Li, C. Ponce De León, L. Berlouis, C. T. Low, and F. C. Walsh, "Progress in redox flow batteries, remaining challenges and their applications in energy storage," *RSC Adv.*, vol. 2, no. 27, pp. 10125–10156, 2012.
- [39] B. Dunn, H. Kamath, and J.-M. Tarascon, "Electrical energy storage for the grid : A battery of choices," *Science*, vol. 334, no. 6058, pp. 928–935 2011.
- [40] BYD, "B-Box BYD," 2018. [Online]. Available: <https://en.byd.com/energy/b-box-ess/>
- [41] B. Diouf and R. Pöde, "Potential of lithium-ion batteries in renewable energy," *Renewable Energy*, vol. 76, pp. 375–380, 2015.
- [42] M. Aneke and M. Wang, "Energy storage technologies and real life applications - A state of the art review," *Appl. Energy*, vol. 179, pp. 350–377, 2016.
- [43] A. I. Stan, M. Swierczynski, D. I. Stroe, R. Teodorescu, and S. J. Andreasen, "Lithium ion battery chemistries from renewable energy storage to automotive and back-up power applications—An overview," in *Proc. Int. Conf. Optim. Elect. Electron. Equipment*, 2014, pp. 713–720.
- [44] T. Zhao, "Sustainable development strategy for EV battery," 2018, pp. 1–31. [Online]. Available: <https://www.ica.org/media/Workshops/2018/Session2ZhaoTongBYD.pdf>

- [45] I. Tsiropoulos, D. Tarvydas, and N. Lebedeva, "Li-ion batteries for mobility and stationary storage applications—Scenarios for costs and market growth," Publications Office of the European Union, Luxembourg, Tech. Rep., 2018.
- [46] I. Trintis, S. Munk-Nielsen, and R. Teodorescu, "Cascaded H-bridge with bidirectional boost converters for energy storage," in *Proc. 14th Eur. Conf. Power Electron. Appl.*, 2011, pp. 1–9.
- [47] "IEC Standard Voltages," IEC Standard 60038:2009, Jun. 2009.
- [48] M. Liu, W. Li, C. Wang, M. P. Polis, L. Y. Wang, and J. Li, "Reliability evaluation of large scale battery energy storage systems," *IEEE Trans. Smart Grid*, vol. 8, no. 6, pp. 2733–2743, Nov. 2017.
- [49] IEEE Standards Association, "IEEE recommended practice and requirements for harmonic control in electric power systems," IEEE Standard 519-2014, 2014.
- [50] IEEE Standards Association, "IEEE Standard for interconnection and interoperability of distributed energy resources with associated electric power systems interfaces," IEEE Standard 1547-2018, 2018, pp. 1–138.
- [51] S. Vazquez, S. M. Lukic, E. Galvan, L. G. Franquelo, and J. M. Carrasco, "Energy storage systems for transport and grid applications," *IEEE Trans. Ind. Electron.*, vol. 57, no. 12, pp. 3881–3895, Dec. 2010.
- [52] J. I. Y. Ota, T. Sato, and H. Akagi, "Enhancement of performance, availability, and flexibility of a battery energy storage system based on a modular multilevel cascaded converter (MMCC-SSBC)," *IEEE Trans. Power Electron.*, vol. 31, no. 4, pp. 2791–2799, Apr. 2016.
- [53] "Semikron," 2020. [Online]. Available: <https://www.semikron.com/products/product-classes/igbt-modules.html>
- [54] P. D. Judge and T. C. Green, "Modular multilevel converter with partially rated integrated energy storage suitable for frequency support and ancillary service provision," *IEEE Trans. Power Del.*, vol. 34, no. 1, pp. 208–219, Feb. 2019.
- [55] A. Hillers and J. Biela, "Optimal design of the modular multilevel converter for an energy storage system based on split batteries," in *Proc. 15th Eur. Conf. Power Electron. Appl. EPE*, 2013, pp. 1–11.
- [56] L. Baruschka and A. Mertens, "Comparison of cascaded H-bridge and modular multilevel converters for BESS application," in *Proc. IEEE Energy Convers. Congr. Expo. Energy Convers. Innov. Clean Energy Future*, 2011, pp. 909–916.
- [57] H. C. Hesse, M. Schimpe, D. Kucevic, and A. Jossen, "Lithium-ion battery storage for the grid—A review of stationary battery storage system design tailored for applications in modern power grids," *Energies*, vol. 10, no. 12, p. 2107, 2017.
- [58] S. Bhim, K. Al-Haddad, and A. Chandra, "Harmonic elimination, reactive power compensation and load balancing in three-phase, four-wire electric distribution systems supplying non-linear loads," *Electric Power Syst. Res.*, vol. 44, pp. 93–100, 1998.
- [59] X. Liang, "Emerging power quality challenges due to integration of renewable energy sources," *IEEE Trans. Ind. Appl.*, vol. 53, no. 2, pp. 855–866, Mar./Apr. 2017.
- [60] T. N. Reddy, M. K. Mishra, and S. Srinivas, "Grid interactive combined supercapacitor/battery energy storage system with power quality features," in *Proc. IEEE Int. Conf. Ind. Technol.*, 2015, pp. 2600–2605.
- [61] H. Lee, B. Y. Shin, S. Han, S. Jung, B. Park, and G. Jang, "Compensation for the power fluctuation of the large scale wind farm using hybrid energy storage applications," *IEEE Trans. Appl. Supercond.*, vol. 22, no. 3, Jun. 2012, Art. no. 5701904.
- [62] Z. Zhang, Y. Zhang, Q. Huang, and W.-J. Lee, "Market-oriented optimal dispatching strategy for a wind farm with a multiple stage hybrid energy storage system," *CSEE J. Power Energy Syst.*, vol. 4, no. 4, pp. 417–424, 2018.
- [63] W. A. Omran, M. Kazerani, and M. M. Salama, "Investigation of methods for reduction of power fluctuations generated from large grid-connected photovoltaic systems," *IEEE Trans. Energy Convers.*, vol. 26, no. 1, pp. 318–327, Mar. 2011.
- [64] Autoriteit Consument & Market (ACM), "Netcode elektriciteit," 2016. [Online]. Available: <https://wetten.overheid.nl/BWBR0037940/2019-10-22>
- [65] B. Zhang, P. Dehghanian, and M. Kezunovic, "Optimal allocation of PV generation and battery storage for enhanced resilience," *IEEE Trans. Smart Grid*, vol. 10, no. 1, pp. 535–545, Jan. 2019.
- [66] M. A. Abusara, J. M. Guerrero, and S. M. Sharkh, "Line-interactive UPS for microgrids," *IEEE Trans. Ind. Electron.*, vol. 61, no. 3, pp. 1292–1300, Mar. 2014.
- [67] W. R. Issa, M. A. Abusara, and S. M. Sharkh, "Control of transient power during unintentional islanding of microgrids," *IEEE Trans. Power Electron.*, vol. 30, no. 8, pp. 4573–4584, Aug. 2015.
- [68] S. D. Izadkhast, "Aggregation of plug-in electric vehicles in power systems for primary frequency control," Ph.D. dissertation, Inst. Res. Technol., Comillas Pontifical Univ., Madrid, Spain, 2017.
- [69] IEEE PES Distribution Systems Analysis Subcommittee Radial Test Feeders, "IEEE European LV Test Feeder," 2015, pp. 1–6. [Online]. Available: <https://site.ieee.org/pes-testfeeders/resources/>
- [70] N. Mahmud and A. Zahedi, "Review of control strategies for voltage regulation of the smart distribution network with high penetration of renewable distributed generation," *Renewable Sustain. Energy Rev.*, vol. 64, pp. 582–595, 2016.
- [71] K. E. Antoniadou-Plytaria, I. N. Kouveliotis-Lysikatos, P. S. Georgi-lakis, and N. D. Hatzigiorgiou, "Distributed and decentralized voltage control of smart distribution networks," *IEEE Trans. Smart Grid*, vol. 8, no. 6, pp. 2999–3008, Nov. 2017.
- [72] P. Wang, D. H. Liang, J. Yi, P. F. Lyons, P. J. Davison, and P. C. Taylor, "Integrating electrical energy storage into coordinated voltage control schemes for distribution networks," *IEEE Trans. Smart Grid*, vol. 5, no. 2, pp. 1018–1032, Mar. 2014.
- [73] C. Sabillon-Antunez, O. D. Melgar-Dominguez, J. F. Franco, M. Lavorato, and M. J. Rider, "Volt-VAR control and energy storage device operation to improve the electric vehicle charging coordination in unbalanced distribution networks," *IEEE Trans. Sustain. Energy*, vol. 8, no. 4, pp. 1560–1570, Oct. 2017.
- [74] CEI - Comitato Elettrotecnico Italiano, "CEI 0-16," 2019. [Online]. Available: <https://www.ceinorme.it/it/norme-cei-0-16-e-0-21.html>
- [75] C. C. E. Italiano, "CEI 0-21," 2019. [Online]. Available: <https://www.ceinorme.it/it/norme-cei-0-16-e-0-21.html>
- [76] "Connection and operation to medium-voltage grid," 2018. [Online]. Available: VDE-AR-N 4110
- [77] "Technical requirements for the connection to and parallel operation with low-voltage distribution networks," 2018. [Online]. Available: VDE-AR-N 4105
- [78] Y. G. Rebours, D. S. Kirschen, M. Trotignon, and S. Rossignol, "A survey of frequency and voltage control ancillary services—Part I: Technical features," *IEEE Trans. Power Syst.*, vol. 22, no. 1, pp. 350–357, Feb. 2007.
- [79] Y. G. Rebours, D. S. Kirschen, M. Trotignon, and S. Rossignol, "A survey of frequency and voltage control ancillary services—Part II: Economic features," *IEEE Trans. Power Syst.*, vol. 22, no. 1, pp. 358–366, Feb. 2007.
- [80] "TenneT B.V.," 2020. [Online]. Available: <https://www.tennet.eu/electricity-market/ancillary-services/fcr-documents/>
- [81] "Elia Group," 2020. [Online]. Available: <https://www.elia.be/en/grid-data/balancing>
- [82] "Rede Eléctrica de España," 2020. [Online]. Available: <https://www.ree.es/es/actividades/operacion-del-sistema-electrico/procedimientos-de-operacion>
- [83] Réseau de Transport d'Électricité, "Frequency ancillary services terms and conditions," 2018. [Online]. Available: http://clients.rte-france.com/lang/an/clients_producteurs/services_clients/services_systeme.jsp
- [84] A. Rahimi, M. Zarghami, M. Vaziri, and S. Vadhva, "A simple and effective approach for peak load shaving using Battery Storage Systems," in *Proc. 45th North Am. Power Symp.*, 2013, pp. 1–5.
- [85] A. J. Pimm, T. T. Cockerill, and P. G. Taylor, "The potential for peak shaving on low voltage distribution networks using electricity storage," *J. Energy Storage*, vol. 16, pp. 231–242, 2018.
- [86] M. Farokhifar, S. Grillo, and E. Tironi, "Loss minimization in medium voltage distribution grids by optimal management of energy storage devices," in *Proc. IEEE PowerTech Grenoble Conf.*, 2013, pp. 1–5.
- [87] A. Nourai, V. I. Kogan, and C. M. Schafer, "Load leveling reduces T&D line losses," *IEEE Trans. Power Del.*, vol. 23, no. 4, pp. 2168–2173, Oct. 2008.
- [88] A. Oudalov, D. Chartouni, and C. Ohler, "Optimizing a battery energy storage system for primary frequency control," *IEEE Trans. Power Syst.*, vol. 22, no. 3, pp. 1259–1266, Aug. 2007.
- [89] P. Mercier, R. Cherkaoui, and A. Oudalov, "Optimizing a battery energy storage system for frequency control application in an isolated power system," *IEEE Trans. Power Syst.*, vol. 24, no. 3, pp. 1469–1477, Aug. 2009.

- [90] D.-I. Stroe, V. Knap, M. Swierczynski, A.-I. Stroe, and R. Teodorescu, "Operation of a grid-connected lithium-ion battery energy storage system for primary frequency regulation: A battery lifetime perspective," *IEEE Trans. Ind. Appl.*, vol. 53, no. 1, pp. 430–438, Jan./Feb. 2017.
- [91] A. Daggett, M. Qadrdan, and N. Jenkins, "Feasibility of a battery storage system for a renewable energy park operating with price arbitrage," in *Proc. IEEE PES Innov. Smart Grid Technol. Conf. Eur. ISGT-Europe*, 2018, pp. 1–6.
- [92] B. Zakeri, S. Syri, and F. Wagner, "Economics of energy storage in the German electricity and reserve markets," in *Proc. Int. Conf. Eur. Energy Markets*, 2017, pp. 1–6.
- [93] "Gestore dei Mercati Energetici S.p.A.," 2020. [Online]. Available: <https://www.mercatoelettrico.org/It/Statistiche/ME/DatiSintesi.aspx>
- [94] "Nord Pool AS," 2019. [Online]. Available: <https://www.nordpoolgroup.com/historical-market-data/>
- [95] J. M. Gantz, S. M. Amin, and A. M. Giacomoni, "Optimal capacity partitioning of multi-use customer-premise energy storage systems," *IEEE Trans. Smart Grid*, vol. 5, no. 3, pp. 1292–1299, May 2014.
- [96] A. Perez, R. Moreno, R. Moreira, M. Orchard, and G. Strbac, "Effect of battery degradation on multi-service portfolios of energy storage," *IEEE Trans. Sustain. Energy*, vol. 7, no. 4, pp. 1718–1729, Oct. 2016.
- [97] R. Moreno, R. Moreira, and G. Strbac, "A MILP model for optimising multi-service portfolios of distributed energy storage," *Appl. Energy*, vol. 137, pp. 554–566, 2015.
- [98] D. Pudjianto, M. Aunedi, P. Djapic, and G. Strbac, "Whole-systems assessment of the value of energy storage in low-carbon electricity systems," *IEEE Trans. Smart Grid*, vol. 5, no. 2, pp. 1098–1109, Mar. 2014.
- [99] J. Kennedy and R. Eberhart, "Particle swarm optimization," in *Proc. IEEE Int. Conf. Neural Networks*, vol. 4, 1995, pp. 1–7.
- [100] J. H. Holland, *Adaptation in Natural and Artificial Systems*. Cambridge, MA, USA: MIT Press, 1992.
- [101] A. Paffrath, M. Henneberger, and J. Mayer, "Particle swarm optimization: Basic concepts, variants and applications in power systems," *IEEE Trans. Evol. Comput.*, vol. 12, no. 2, pp. 171–195, Apr. 2008.
- [102] A. Vieira Pombo, J. Murta-Pina, and V. Fernão Pires, "Multiobjective formulation of the integration of storage systems within distribution networks for improving reliability," *Electric Power Syst. Res.*, vol. 148, pp. 87–96, 2017.
- [103] S. W. Alnaser and L. F. Ochoa, "Optimal sizing and control of energy storage in wind power-rich distribution networks," *IEEE Trans. Power Syst.*, vol. 31, no. 3, pp. 2004–2013, May 2016.
- [104] R. Hemmati, H. Saboori, and M. A. Jirdehi, "Stochastic planning and scheduling of energy storage systems for congestion management in electric power systems including renewable energy resources," *Energy*, vol. 133, pp. 380–387, Aug. 2017.
- [105] A. S. Awad, T. H. EL-Fouly, and M. M. Salama, "Optimal ESS allocation for benefit maximization in distribution networks," *IEEE Trans. Smart Grid*, vol. 8, no. 4, pp. 1668–1678, Jul. 2017.
- [106] E. Grover-Silva, R. Girard, and G. Kariniotakis, "Optimal sizing and placement of distribution grid connected battery systems through an SOCP optimal power flow algorithm," *Appl. Energy*, vol. 219, pp. 385–393, 2018.
- [107] K. Mahani, F. Farzan, and M. A. Jafari, "Network-aware approach for energy storage planning and control in the network with high penetration of renewables," *Appl. Energy*, vol. 195, pp. 974–990, 2017.
- [108] M. R. Jannesar, A. Sedighi, M. Savaghebi, and J. M. Guerrero, "Optimal placement, sizing, and daily charge/discharge of battery energy storage in low voltage distribution network with high photovoltaic penetration," *Appl. Energy*, vol. 226, pp. 957–966, 2018.
- [109] M. Nick, R. Cherkaoui, and M. Paolone, "Optimal siting and sizing of distributed energy storage systems via alternating direction method of multipliers," *Int. J. Elect. Power Energy Syst.*, vol. 72, pp. 33–39, 2015.
- [110] H. Akhavan-Hejazi and H. Mohsenian-Rad, "Energy storage planning in active distribution grids: A chance-constrained optimization with non-parametric probability functions," *IEEE Trans. Smart Grid*, vol. 9, no. 3, pp. 1972–1985, May 2018.
- [111] G. Carpinelli, G. Celli, S. Mocci, F. Mottola, F. Pilo, and D. Proto, "Optimal integration of distributed energy storage devices in smart grids," *IEEE Trans. Smart Grid*, vol. 4, no. 2, pp. 985–995, Jun. 2013.
- [112] A. Giannitrapani, S. Paoletti, A. Vicino, and D. Zarrilli, "Optimal allocation of energy storage systems for voltage control in LV distribution networks," *IEEE Trans. Smart Grid*, vol. 8, no. 6, pp. 2859–2870, Nov. 2017.
- [113] P. Lazzeroni and M. Repetto, "Optimal planning of battery systems for power losses reduction in distribution grids," *Electric Power Syst. Res.*, vol. 167, pp. 94–112, 2019.
- [114] M. Nick, R. Cherkaoui, and M. Paolone, "Optimal planning of distributed energy storage systems in active distribution networks embedding grid reconfiguration," *IEEE Trans. Power Syst.*, vol. 33, no. 2, pp. 1577–1590, Mar. 2018.
- [115] A. R. Camargo, C. A. Castro, and M. Lavorato, "Optimal allocation of energy storage devices in distribution systems considering lifetime characteristics of batteries," in *Proc. IEEE Int. Conf. Power Syst. Technol.*, 2016, pp. 1–6.
- [116] S. B. Karanki, D. Xu, B. Venkatesh, and B. N. Singh, "Optimal location of battery energy storage systems in power distribution network for integrating renewable energy sources," in *Proc. IEEE Energy Convers. Congr. Expo.*, 2013, pp. 4553–4558.
- [117] M. Sedghi, M. Aliakbar-Golkar, and M. R. Haghifam, "Distribution network expansion considering distributed generation and storage units using modified PSO algorithm," *Int. J. Elect. Power Energy Syst.*, vol. 52, no. 1, pp. 221–230, 2013.
- [118] K. K. Mehmood, S. U. Khan, S.-J. Lee, Z. M. Haider, M. K. Rafique, and C.-H. Kim, "Optimal sizing and allocation of battery energy storage systems with wind and solar power DGs in a distribution network for voltage regulation considering the lifespan of batteries," *IET Renewable Power Gener.*, vol. 11, no. 10, pp. 1305–1315, 2017.
- [119] A. F. Crossland, D. Jones, and N. S. Wade, "Planning the location and rating of distributed energy storage in LV networks using a genetic algorithm with simulated annealing," *Int. J. Elect. Power Energy Syst.*, vol. 59, pp. 103–110, 2014.
- [120] C. Brivio, "Battery energy storage systems: Modelling, applications and design criteria," Ph.D. dissertation, Politecnico di Milano, Milan, Italy, 2012. [Online]. Available: <http://hdl.handle.net/10589/136844>
- [121] H. H. Eldeeb, S. Faddel, and O. A. Mohammed, "Multi-objective optimization technique for the operation of grid tied PV powered EV charging station," *Electric Power Syst. Res.*, vol. 164, pp. 201–211, 2018.
- [122] R. C. Dugan, J. A. Taylor, and D. Montenegro, "Energy storage modeling for distribution planning," *IEEE Trans. Ind. Appl.*, vol. 53, no. 2, pp. 954–962, Mar./Apr. 2017.
- [123] M. Dubarry and A. Devie, "Battery durability and reliability under electric utility grid operations: Representative usage aging and calendar aging," *J. Energy Storage*, vol. 18, pp. 185–195, 2018.
- [124] M. T. Lawder et al., "Battery energy storage system (BESS) and battery management system (BMS) for grid-scale applications," *Proc. IEEE*, vol. 102, no. 6, pp. 1014–1030, Jun. 2014.
- [125] R. H. Byrne, T. A. Nguyen, D. A. Copp, B. R. Chalamala, and I. Gyuk, "Energy management and optimization methods for grid energy storage systems," *IEEE Access*, vol. 6, pp. 13231–13260, 2017.
- [126] A. Yazdani and R. Iravani, *Voltage-Sourced Converters in Power Systems*. Hoboken, NJ, USA: Wiley, 2010.
- [127] L. Wang, D. H. Liang, A. F. Crossland, P. C. Taylor, D. Jones, and N. S. Wade, "Coordination of multiple energy storage units in a low-voltage distribution network," *IEEE Trans. Smart Grid*, vol. 6, no. 6, pp. 2906–2918, Nov. 2015.
- [128] S. Hashemi and J. Østergaard, "Efficient control of energy storage for increasing the PV hosting capacity of LV grids," *IEEE Trans. Smart Grid*, vol. 9, no. 3, pp. 2295–2303, May 2018.
- [129] K. Christakou, D. C. Tomozei, M. Bahramipناه, J. Y. Le Boudec, and M. Paolone, "Primary voltage control in active distribution networks via broadcast signals: The case of distributed storage," *IEEE Trans. Smart Grid*, vol. 5, no. 5, pp. 2314–2325, Sep. 2014.
- [130] D. Zarrilli, A. Giannitrapani, S. Paoletti, and A. Vicino, "Energy storage operation for voltage control in distribution networks: A receding horizon approach," *IEEE Trans. Control Syst. Technol.*, vol. 26, no. 2, pp. 599–609, Mar. 2018.
- [131] Y. Wang, K. T. Tan, X. Y. Peng, and P. L. So, "Coordinated control of distributed energy-storage systems for voltage regulation in distribution networks," *IEEE Trans. Power Del.*, vol. 31, no. 3, pp. 1132–1141, Jun. 2016.
- [132] J. Von Appen, T. Stetz, M. Braun, and A. Schmiegel, "Local voltage control strategies for PV storage systems in distribution grids," *IEEE Trans. Smart Grid*, vol. 5, no. 2, pp. 1002–1009, Mar. 2014.
- [133] S. J. Lee et al., "Coordinated control algorithm for distributed battery energy storage systems for mitigating voltage and frequency deviations," *IEEE Trans. Smart Grid*, vol. 7, no. 3, pp. 1713–1722, May 2016.

- [134] M. Zeraati, M. E. Hamedani Golshan, and J. M. Guerrero, "Distributed control of battery energy storage systems for voltage regulation in distribution networks with high PV penetration," *IEEE Trans. Smart Grid*, vol. 9, no. 4, pp. 3582–3593, Jul. 2018.
- [135] X. Gao, F. Sossan, K. Christakou, M. Paolone, and M. Liserre, "Concurrent voltage control and dispatch of active distribution networks by means of smart transformer and storage," *IEEE Trans. Ind. Electron.*, vol. 65, no. 8, pp. 6657–6666, Aug. 2018.
- [136] K. Worthmann, C. M. Kellett, P. Braun, L. Grüne, and S. R. Weller, "Distributed and decentralized control of residential energy systems incorporating battery storage," *IEEE Trans. Smart Grid*, vol. 6, no. 4, pp. 1914–1923, Jul. 2015.
- [137] Y. Song *et al.*, "Optimal operation of battery energy storage system considering distribution system uncertainty," *IEEE Trans. Sustain. Energy*, vol. 9, no. 3, pp. 1051–1060, Jul. 2018.
- [138] P. Ariyaratna, K. M. Muttaqi, and D. Sutanto, "A novel control strategy to mitigate slow and fast fluctuations of the voltage profile at common coupling point of rooftop solar PV unit with an integrated hybrid energy storage system," *J. Energy Storage*, vol. 20, pp. 409–417, 2018.
- [139] B. Olek and M. Wierzbowski, "Local energy balancing and ancillary services in low-voltage networks with distributed generation, energy storage, and active loads," *IEEE Trans. Ind. Electron.*, vol. 62, no. 4, pp. 2499–2508, Apr. 2015.
- [140] L. H. Macedo, J. F. Franco, and M. J. Rider, "Optimal operation of distribution networks considering energy storage devices," *IEEE Trans. Smart Grid*, vol. 6, no. 6, pp. 2825–2836, Nov. 2015.
- [141] A. Di Giorgio, F. Liberati, A. Lanna, A. Pietrabissa, and F. D. Priscoli, "Model predictive control of energy storage systems for power tracking and shaving in distribution grids," *IEEE Trans. Sustain. Energy*, vol. 8, no. 2, pp. 496–504, Apr. 2017.
- [142] A. Saez-De-Ibarra, A. Milo, H. Gaztanaga, V. Debusschere, and S. Bacha, "Co-optimization of storage system sizing and control strategy for intelligent photovoltaic power plants market integration," *IEEE Trans. Sustain. Energy*, vol. 7, no. 4, pp. 1749–1761, Oct. 2016.
- [143] "Alfen B.V," 2017, [Online]. Available: <https://alfen.com/nl/nieuws/solar-global-kiest-voor-mega-energieopslags-systeem-van-alfen>
- [144] "US Department of Energy, Global energy storage database," 2019. [Online]. Available: <http://www.energystorageexchange.org/>
- [145] "Navigator research leaderboard: Utility-scale energy storage systems integrators," 2020. [Online]. Available: <https://www.navigatorresearch.com/reports/>
- [146] "Fluence," 2018. [Online]. Available: <https://fluenceenergy.com/wp-content/uploads/2019/02/lb-essi-18-executi-ve-summary.pdf>
- [147] TenneT TSO BV, "End report FCR pilot," 2018, pp. 1–35. [Online]. Available: <https://www.tennet.eu/electricity-market/ancillary-services/fcr-documents/>



MARCO STECCA (Student Member, IEEE) received the bachelor's degree in energy engineering from the University of Padova, Italy, in 2016, and the master degree in electrical engineering from Politecnico di Milano, Italy, in 2018. Since 2018 he has been working toward the Ph.D. degree in the field of grid scale battery energy storage systems with the Delft University of Technology. His research interests include grid connected DC-AC power electronics converters and energy storage system integration in distribution grids.



LAURA RAMIREZ-ELIZONDO (Member, IEEE) received the bachelor's degree in electrical engineering and in music with a major in Piano at the Universidad de Costa Rica. She graduated with honors from the M.Sc. studies in electrical power engineering from the Delft University of Technology in 2007, and the Ph.D. degree in electrical engineering from the Delft University of Technology (2013). She is a Assistant Professor at the DC Systems, Energy Conversion & Storage group.



THIAGO BATISTA SOEIRO (Senior Member, IEEE) received the B.S. (Hons.) and M.S. degrees in electrical engineering from the Federal University of Santa Catarina, Florianopolis, Brazil, in 2004 and 2007, respectively, and the Ph.D. degree from the Swiss Federal Institute of Technology, Zurich, Switzerland, in 2012. During the masters and Ph.D. studies, he was a Visiting Scholar at the Power Electronics and Energy Research Group, Concordia University, Montreal, QC, Canada, and at the Center for Power Electronics Systems,

Blacksburg, VA, USA, respectively. From 2012 to 2013, he was a Senior Engineer at the Power Electronics Institute, the Federal University of Santa Catarina. From 2013 to 2018, he was a Senior Scientist at the Corporate Research Center, ABB Switzerland Ltd., Baden-Dattwil, Switzerland. Since 2018, he has been an Assistant Professor at the DC Systems, Energy Conversion and Storage Group, Delft University of Technology, Delft, The Netherlands. His research interests include advanced power converters and dc system integration.



PAVOL BAUER (Senior Member, IEEE) received the master's degree in electrical engineering from the Technical University of Kosice in 1985 and the Ph.D. degree from the Delft University of Technology in 1995. He is currently a Full Professor with the Department of Electrical Sustainable Energy of Delft University of Technology and head of DC Systems, Energy Conversion and Storage group. He is also Professor at the Brno University of Technology in Czech Republic and Honorary Professor at Politehnica University Timișoara in

Romania. From 2002 to 2003, he was working partially at KEMA (DNV GL, Arnhem) on different projects related to power electronics applications in power systems. He published over 120 journal and 500 conference papers in his field (with H factor Google scholar 40, Web of Science 26), he is an author or co-author of eight books, holds seven international patents and organized several tutorials at the international conferences. He has worked on many projects for industry concerning wind and wave energy, power electronic applications for power systems such as Smarttrafo; HVDC systems, projects for smart cities such as PV charging of electric vehicles, PV and storage integration, contactless charging; and he participated in several Leonardo da Vinci, H2020 and Electric Mobility Europe EU Projects as Project partner (ELINA, INETELE, E-Pragmatic, Micact, Trolley 2.0, OSCD, P2P, Progressus) and Coordinator (PEMCWebLab.com-Edipe, SustEner, Eranet DCMICRO). His main research interest is power electronics for charging of electric vehicles and DC grids. He is a Senior Member of the IEEE ('97), former Chairman of Benelux IEEE Joint Industry Applications Society, Power Electronics and Power Engineering Society chapter, Chairman of the Power Electronics and Motion Control (PEMC) council, member of the Executive Committee of European Power Electronics Association (EPE) and also member of international steering committee at numerous conferences.



PETER PALENSKY (Senior Member, IEEE) received the M.Sc. degree in electrical engineering in 1997 the Ph.D. degree in 2001, and his Habilitation in 2015, all from the Vienna University of Technology, Austria. He co-founded an Envidatec, a German startup on energy management and analytics, and joined the Lawrence Berkely National Laboratory, CA, as Researcher, and the University of Pretoria, South Africa, in 2008. In 2009, he was appointed Head of business unit on sustainable building technologies at the Austrian Institute of Technology

(AIT), and later the first Principal Scientist for complex energy systems at the AIT. In 2014, he was appointed Full Professor for intelligent electric power grids at TU Delft. He is active in international committees like ISO or CEN and serves an IEEE IES AdCom Member-at-Large in various functions for the IEEE. He is Editor in Chief of the *IEEE Industrial Electronics Magazine*, Associate Editor for several other IEEE publications, and regularly organizes IEEE conferences. His main research fields are energy automation networks, smart grids, and modeling intelligent energy systems.