

Received March 17, 2020, accepted April 9, 2020, date of publication April 16, 2020, date of current version May 5, 2020.

Digital Object Identifier 10.1109/ACCESS.2020.2988397

A Comprehensive State-of-the-Art Survey on Hybrid Renewable Energy System Operations and Planning

OLUBAYO MOSES BABATUNDE¹, (Student Member, IEEE),
JOSIAH LANGE MUNDA¹, (Member, IEEE), AND
YSKANDAR HAMAM^{1,2}, (Senior Member, IEEE)

¹Department of Electrical Engineering, Tshwane University of Technology, Pretoria 0001, South Africa

²Ecole Supérieure d'Ingénieurs Electrotechnique et Electronique (ESIEE) Paris, 93162 Noisy-le-Grand, France

Corresponding author: Olubayo Moses Babatunde (olubayobabatunde@gmail.com)

This work was supported in part by the National Research Foundation of South Africa and in part by The World Academy of Science (TWAS) under Grant121078.

ABSTRACT The use of hybrid renewable energy systems among household consumers in sub-Saharan Africa (SSA) is increasingly gaining attention. This is due to low electrification rates in many of the countries in SSA. A hybrid energy system for power generation combines various energy systems, either renewable or a combination of renewable and fossil-powered sources for optimal power extraction and operation. In the era of decarbonization of the electricity grid through the use of renewable energy, hybridization of sources is an essential condition for the production of electricity. Based on current quest for renewable energy (RE) expansion in the global energy mix, optimum conditions for the production and adoption of hybrid renewable energy systems (HRES) at micro-levels are indispensable and must be advocated for. This can be justified based on the perpetually rising cost of energy for socio-economic development. This paper presents a survey of major issues regarding the motivations and specific benefits behind the adoption of HRES. Also presented, is a discussion on different renewable energy sources that can be adopted for HRES application for both grid and off-grid consumers. Furthermore, a discussion on the important issues as it pertains to the design and implementation of HRES is also presented. Finally, a policy discussion on the affordability of HRES in a low-income household is presented.

INDEX TERMS Hybrid renewable energy, intermittent renewable energy, low-income household, operations and planning, decarbonization, affordability.

I. INTRODUCTION

The global energy demand across all sectors of human endeavors has grown over the past few decades with many literature and reports on energy studies attributing this increase to socio-economic developments. In most cases, these socio-economic developments are related to massive technological breakthroughs and industrial advancements. Nevertheless, population growth and progression in social status also contribute to an increase in energy demand. A major form of energy that supports socio-economic developments is electricity. Electricity penetrates its tentacles deep into every sector essential for the existence of the society.

The associate editor coordinating the review of this manuscript and approving it for publication was Xiaodong Liang¹.

Therefore, in order to sustain modern civilization, adequate and reliable access to electricity is very important [1]. Apart from being a major driver of socio-economic activities in the urban areas, reliable and adequate electricity is also important in improving quality of life in rural communities. For example, access to electricity for water pumping, lighting and for powering refrigerators used for storing vaccines will make life easy for rural dwellers. Furthermore, micro-economic activities in rural communities such as small scale agricultural activities require electricity for sustenance with regards to emerging technological trends [2]. From the foregoing, it is evident that the lack of or inadequate access to electricity can limit the quality of life, provision of quality public services, and modern economic activities [3]. Apart from these, lack of or inadequate electricity access can hamper the

adoption of modern technologies (in the banking industry, educational sector, agricultural sector and finances) aimed at reducing unemployment rates and increasing access to adequate healthcare. In order to improve the standard of living, access to electricity is essential. Electricity will play a pivotal role in the attainment of the globally accepted sustainable development goals (SDGs) proposed by the United Nations because it cuts across almost all human activities. This is why SDG number 7 specifies, ensuring “access to afford able, reliable, sustainable and modern energy for all” by 2030 [4]. If achieved, it has the tendency to reduce poverty, reduce hunger, improve health and well-being of all, improve the quality of education, enhance access to clean water and improve economic growth. Furthermore, access to clean and affordable electricity for all can create more industries, enhance innovations, and reduce climate change and its effects by ensuring responsible consumption and sustainable cities and communities. It is, therefore, difficult to achieve or conceive a robust and strong economy or an agile and productive household with massive electricity deficit.

Due to various government interventions and regulatory policies, (e.g. subsidies, feed-in-tariffs, market friendly policies), RESs are increasingly becoming more cost-effective and a major share of the power plant mix worldwide [5]. As such, it is reported that renewable energy accounts for one-third of the total electricity power generation worldwide [6]–[8]. Out of the emerging RESs commercially available for electricity generation, wind and solar PV have been given extensive research attention and practical implementation. This is because the efficiencies of these technologies are continuously being improved and can be adopted both for large scale applications and in modular form in areas with sufficient resource. For instance, it is reported that a solar generating facility occupying approximately 0.3% of the land mass in North Africa has the potential to meet all the energy demand of the European Union countries [9]. Due to its modularity, solar PV technology is the most commonly used RESs in meeting energy demands among off-grid household consumers. The output of a solar PV panel is dependent on the availability of the solar resource. This means that the power output of a solar PV panel depends on the degree of intermittency of solar resource and daily weather fluctuations. In order to compensate for the setback caused by intermittency of resources, the use of hybrid systems is usually proposed. Another means of clipping the effects of intermittency is the use of energy storage systems [10]. This will reduce the effect of resource availability fluctuations and help in getting a fairly smooth and constant output [11], [12]. Extracting the maximum obtainable output from the solar panel can also contribute to a technically and economically efficient energy system. This requires that all components are optimally sized. Several studies focusing on the techno-economic and environmental feasibility of standalone and grid connected hybrid renewable energy systems have been conducted [13]–[17] and they have been reported to be economically competitive when compared to the use of fossil fuel-powered generator.

The traditional way of power generation for off-grid applications typically involves the use of single standalone energy source such as wind, small hydro, biomass, solar and captive diesel/gasoline generators. Emerging electric power generation schemes is advocating for the hybridization of energy sources instead of power generation from single sources. With the various breakthroughs in renewable energy technologies, the hybridization of renewable energy sources has a tendency to deliver efficient and reliable power. A hybrid energy system is a power generation scheme that combines more than one energy sources to obtain a synchronized and optimal power output. Typically, the output of a hybrid energy system is either electricity, heat, or a combination of both (co-generation). Since most renewable energy sources are intermittent in nature, their power outputs are variable and unreliable. A combination of various energy sources will compensate for the variable nature of the power outputs to produce a more reliable power output. Apart from the benefit of variability reduction offered by HRES, the reduction or elimination (in small-scale application) of emission is also a major advantage of the system. With electricity generation accounting for more than 42% of the global CO_2 emission [18], the use of HRES is inevitable. It will encourage the implementation of more renewable energy projects and reduce the operations of fossil-powered energy systems. This means that, HRES configuration will basically serve as a means of ensuring sustainability (consumption, environment) in the electricity industry.

In recent times, the adoption of hybrid renewable energy systems has massively encouraged the rise of the renewable energy penetration in global power plant mix. This is particularly evident in the rate at which it is embraced by micro-grid facilities in grid-isolated communities. Figure 1 presents an illustration of a hybrid PV-wind-battery system that can be adopted for household application. Adoption of HRES will encourage a sustainable future for all. Promoting sustainability is the focal point of many national and international organizations that have proposed several sustainability-enabling

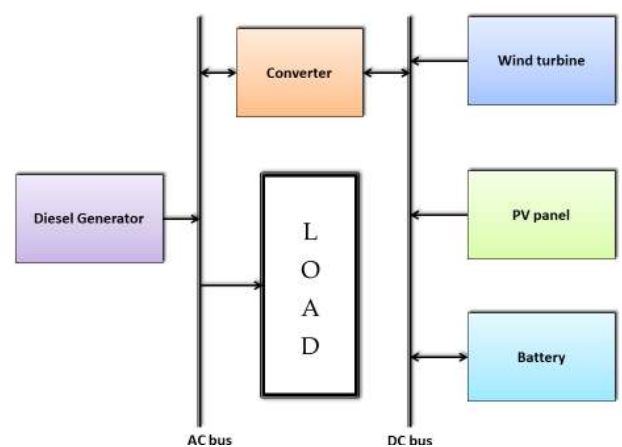

FIGURE 1. Block diagram of a typical PV-Wind battery HRES.



FIGURE 2. Sustainable development goals.

policies and frameworks. One of such is the SDGs as listed by the United Nations (Figure 2). The overall objectives of the SDGs are to end poverty, improve health and education, reduce inequality, and boost economic growth and preserve the environment for the future [19]. Another of such is the Paris Agreement which recommends that to save the planet; ‘the increase in average global temperature must be kept well below 2°C above the pre-industrial level and to limit the increase to 1.5°C [20].

Ideally, the concept of sustainability in HRES adoption involves the combination of various perspectives that encompasses social, technical, economic, environment, political and relevant enabling policies. For instance, a sound technical expertise is needed to optimally size a HRES system to improve reliability and reduce or avoid economic wastage. However, an accurately sized HRES is not sufficient for the sustainability of such a system. It is also important that consumers are able to acquire the system or the cost of energy attributed to such HRES without it negatively affecting their finances. Therefore, this article reviews some integrated issues concerning hybrid power system implementation.

A. PREVIOUS REVIEWS

In an attempt to contribute to the body of knowledge with respect to renewable energy systems adoption, various technical reviews and surveys have been conducted in the last few years. Bhandari *et al.*, presented a review on the modeling, criteria and methodologies for the optimization of HRES [21]. Another review which focused on the impact of renewable energy adoption for rural electrification on a national scale has also been presented by Hossain *et al.* [22]. Some studies have also presented a review of a range of modeling tools and methods applicable in HRES planning [22]–[24]. More specifically, Bahramara *et al.*, focused on a comprehensive review that discusses the use of HOMER software for the optimal planning of HRES [25]. In their

own work, Olatomiwa *et al* reviewed various energy management schemes in HRES [26]. A survey that focused on the sizing approaches, configurations and control schemes for HRES was presented [27]. The review conducted by Al-falahi *et al.*, focused on new developments in size optimization approaches and software tools for sizing standalone solar and wind HRES [28]. Siddaiah and Saini also focused their survey on HRES planning, configurations, modeling and optimization techniques for standalone applications [29]. A review that focused on issues related to integration, configurations, storage options, sizing methodologies and system control for energy flow management of HRES has also been presented [30].

Although the aforementioned studies have covered a vast range of contemporary issues on the sizing of HRES, a state-of-the-art survey that combines the social, technical (optimization approaches), economic, environmental, policy aspect of deploying HRES is yet to be reported. Furthermore, since one of the aims of the SDGs captures “clean and affordable energy for all”, it is also essential that a discussion on how low-income earners can acquire HRES be presented. Given the prospects of HRES in providing clean and affordable energy at all income-levels, this article bridges the aforementioned knowledge gap by presenting a review on the emerging issues surrounding off-grid HRES implementation and acquisition for household use in developing countries.

B. THIS REVIEW

Given in Table 1 is the summary of the various review and surveys papers that have contributed to the development of the HRES subject. It is evident that the aspects of affordability, application of multi-criteria methodologies to HRES, description of formulation, uncertainty analysis, drivers and challenges of HRES, HRES planning, comparison of studies has either received low attention or has not been previously presented. These themes and a few others (see Table 1) are

TABLE 1. Comparison of previous reviews/surveys with present study.

	[21]	[22]	[23]	[24]	[25]	[26]	[27]	[28]	[29]	[30]	[32]	[33]	This survey
Formulation and mathematical description	✓									✓	✓	✓	✓
Optimization methods	✓			✓	✓		✓	✓	✓	✓	✓	✓	✓
Uncertainty analysis			✓										✓
Control and management strategies						✓	✓			✓			✓
Energy storage										✓	✓	✓	✓
Performance metrics							✓	✓		✓			✓
HRES sources/ potentials	✓	✓										✓	✓
HRES classifications	✓						✓	✓	✓	✓	✓	✓	✓
HRES drivers and challenges													✓
HRES planning			✓						✓				✓
Reliability analysis	✓				✓				✓	✓	✓	✓	✓
MCDM													✓
Affordability discussion													✓
Comparision of studies								✓					✓
Distribution of research													✓

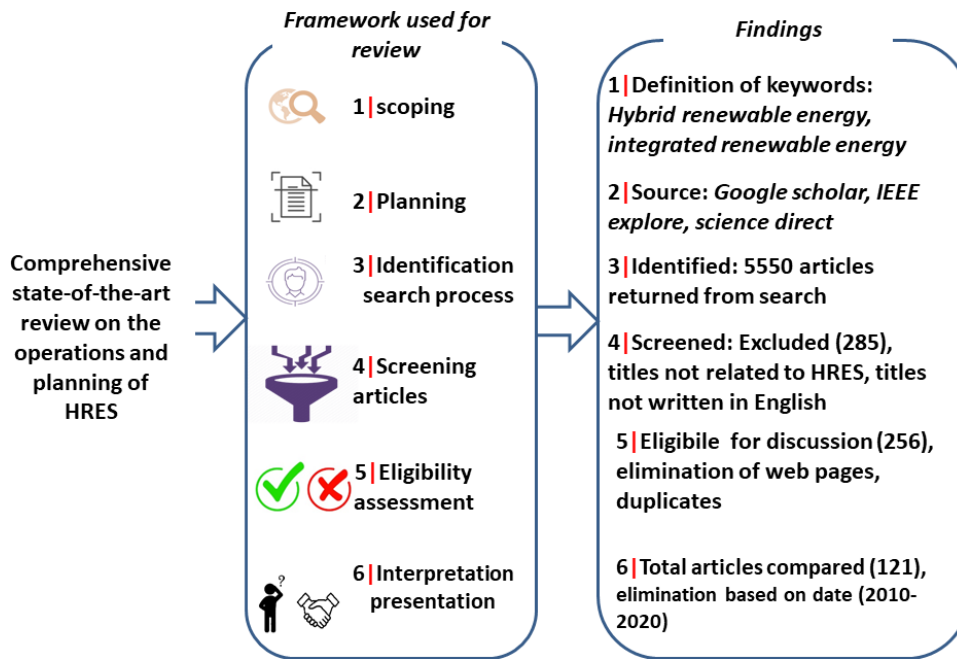

FIGURE 3. Methodological approach for selecting the reviewed studies.

presented in this paper. This paper, therefore, presents a comprehensive state-of-the-art review on the various aspect of HRES operations and planning.

This review adopts a comprehensive literature search technique. Initial search was performed on Google scholar using the keyword “hybrid renewable energy systems” and “integrated renewable energy systems”. This search led to further searches on prominent journal database such as IEEE-explore

and science direct. Details of how the literatures were selected is shown in Figure 3. The final comparisons were based on articles published between 2010 and 2020 (section XI).

II. DRIVERS AND CHALLENGES OF HRES ADOPTION

A. DRIVERS

According to Darmani *et al.*, the driving force behind renewable energy technologies may be divided into 5 broad

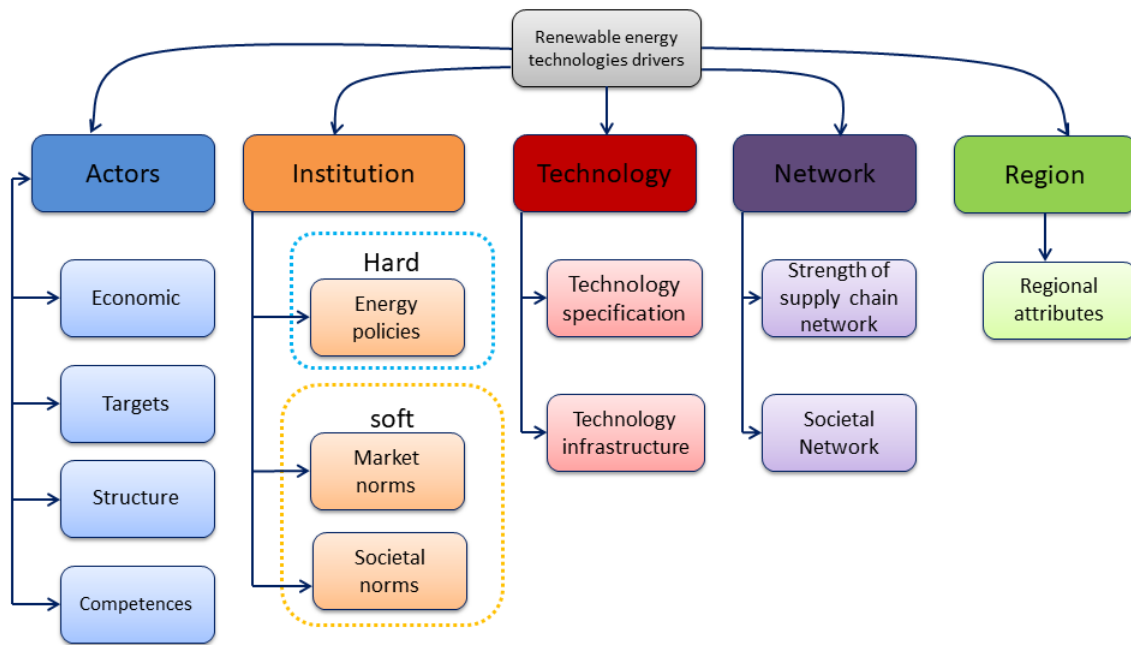

FIGURE 4. Drivers of renewable energy technologies. [31].

categories viz: actors, institution, technology, network and region (Figure 4) [31]. This section discusses some of the drivers of HRES.

1) ECONOMIC DRIVERS

The global economic meltdown has affected many formal and informal sectors in the society including the electricity industry. With the frequent fluctuations in price of fossil fuels (gas, oil and coal), the cost of energy from power plants powered by these sources of fuel is also on the rise. Apart from this, unrest in oil, gas, coal producing regions, change in government, and mismanagement are some of the causes of economic uncertainties which also affect the prices of these fuels. In many developing countries in sub-Sahara Africa with low access rates and unreliable supply, captive gasoline and diesel generators are the main sources of electricity generation [34], and as such the effects of changes in fuel prices is usually more pronounced among electricity consumers. Furthermore, the associated recurring cost of operating and maintaining the captive generators for adequate electricity supply is massive and economically unsustainable for many [35]–[42]. Hence, the economic implication of running fossil-powered captive generators and the costs associated with the transportation of the fuel is a major driver for investments in HRES. One of the main objectives behind the adoption of off-grid HRES is to have access at reduced electricity prices as compared to the use of captive generators (diesel and gasoline). Since off-grid HRES do not require installation of new transmission lines, the cost of energy is usually reduced by as much as 30% [43]. The contingency costs avoided by the improved reliability offered by HRES over weak grid systems are also a major economic factor that encourages the proliferation of HRES.

2) ENVIRONMENTAL DRIVERS

The quest to strike a balance between energy production and sustainable environment is one of the major priorities of the various stakeholders in the electricity industry. This is due to the emergence of the negative effects of climate change being presently experienced all over the globe. In the reality of the global economic constraints, it is essential that climate change mitigation techniques are put in place to avoid the negative economic pressure that emanates from climate change. Consequently, decision makers have proposed various policies at national, regional and international levels to ensure environmental conservation [44]. These policies aim to reduce greenhouse gas (GHG) emissions and preserve the environment. One of such is increased inclusion of renewable energy in the electricity sector. Since the energy sector is also a major contributor to the climate change, it is essential to increase the share of renewable energy in the global energy mix. In order to ensure this, Europe has established a policy that ensures that electricity providers consider cleaner energy sources [45]. Since the power outputs of PV and wind technologies which are the most common RE sources are intermittent in nature, their hybridization is usually encouraged.

3) TECHNOLOGICAL ADVANCEMENTS

Various technological breakthroughs with respect to renewable energy and energy storage have paved the way for the recent increase in the adoption of renewable energy-assisted electricity generation for both large and small scale applications. This has in turn increased the efficiencies of the technologies as well as reduced the costs of procurement for these technologies. Because of these technological advancements, the cost of procuring wind turbines has seen a reduction of

between 30–40% since 2009, while that of solar PV panels has gone down by approximately 80% since the end of 2019 [46]. As such more electricity consumers can now afford to acquire HRES. Another technological breakthrough that favours the adoption of HRES is the development of more efficient energy storage systems. With some remarkable emerging technological developments in energy storage system (ESS) technologies [47]–[49], market prices of products are falling and more energy can be stored during periods of sufficiency of renewable energy sources.

4) INADEQUATE ELECTRICITY SUPPLY

In many developing countries, especially sub-Sahara Africa, electrification rates are very low [3]. Apart from this, in many cases, the available electricity from the grid is unreliable. This usually results in frequent forced outages and load shedding. Inadequate access to electricity can have a serious adverse effect on the socio-economic activities of the people and the health sector. Inadequate access to electricity is usually an offshoot of poor planning, inadequate and reckless management of resources, handicap policies, budget constraints and more importantly absence of effective financing and implementation frameworks. The shortage of electricity supply can be mitigated through the use of off-grid standalone HRES by both rural and urban electricity consumers.

5) SOCIO-POLITICAL FACTORS

Energy alternative choices are usually subject to socio-political perspectives. Some of these include, power balances, social acceptance, governmental structure, and actions taken by political elites, individuals and groups. With the pressure of the international community to limit GHGs emission, more awareness is being created across the world. Such awareness has been able to influence the decision taken by political office holders on the choice of national energy options, with renewable energy sources as priorities. Furthermore, emerging political elites are now encouraged to explore the use of hybrid renewable energy to power remote communities and ensure clean and affordable energy for all.

6) RENEWABLE ENERGY RESOURCE AVAILABILITY

In remote locations, where grid extension is not profitable to utility companies, the use of standalone distributed generators is usually economical and preferred. Traditionally, diesel/gas powered generators are employed for such applications. With the emergence of cheap renewable energy technologies like wind turbine and solar PV, the hybridization of these renewable energy sources with the existing diesel/gas-powered generators offers cheaper electricity for consumers and more revenue for the utility company. Geographical locations with abundance of these renewable energy resources can opt for hybrid renewable energy systems to meet their energy needs.

7) ENABLING POLICIES AND INCENTIVES

Sound and relevant renewable energy policies are also responsible for the growth of HRES. Various countries have

come up with enabling policies that would encourage the integration of renewable energy resource both at macro and micro levels. Many of such policies are either region or country-specific, designed to raise the penetration of renewable energy to a specific level with long-term economic and environmental benefits [50]. Some other policies involve commercialization and market restructuring that is targeted at encouraging investors in picking interests in the establishment of renewable energy related businesses. In Europe, climate change regulatory schemes that encourage renewable energy use in mitigating energy security challenges are continuously being proposed and implemented. These policies have birthed various incentive schemes that promote renewable energy utilization. One of such incentives is the renewable energy subsidies that are targeted at reducing the cost of power generated from renewable energy sources [51]. Others include feed-in-tariffs, endowment of funds for research related to HRES, provision of capital base for establishment of renewable energy-based power schemes [5], [51]–[53]. All these schemes and many more are also responsible for the development of HRES.

III. RENEWABLE ENERGY SOURCES WITH POTENTIALS OF HRES APPLICATION

This section discusses some of the renewable energy sources that can provide electricity for residential households as well as remote communities especially in developing communities. These include biomass, solar, and wind.

A. BIOMASS

Biomass, a form of renewable energy source is organic matter that is derived from animals and plants. Biomass contains energy stored from sunlight. The process (for plants) starts with a process of energy absorption from the sun-photosynthesis. By burning biomass, a chemical process converts the energy stored in the biomass to release heat. Biomass as a form of renewable energy source, differs from fossil fuels, but uses the process of combustion (as opposed to PV, wind, geothermal, hydro), and produces appreciable quantities of air pollutants [54]. Biomass can be in form of liquid bio-fuels or biogas. Broadly speaking, biomass can come in form of agricultural waste from crop residues, biodegradable wastes from industrial sludge, dung and food waste and forest bioenergy resources [2]. In many rural areas of developing countries, this is still a major source of energy. Since there are a lot of agricultural wastes in the rural communities, this form of energy can be explored on large scale to combat the issues of low electricity access rates in many rural communities. This can also be implemented in urban centres with large amount of human and food wastes. There are various strategies of obtaining energy from biomass. Biomass feedstock can be used to produce steam or heat for the generation of electricity or other useful bio-fuel such as bio-methane, bio-ethanol, bio-diesel, and biomass pellets [2], [55]. Biomass has already found application in combined heat and power (CHP) for both small and large scale

purposes [56]–[62]. The use of biomass for energy production depends on factors related to emission coefficient, technology efficiency, resource accessibility, land use/ownership policies, social acceptance, and costs. Due to the concerns about water use policies, land use for food crops, and the undersubsidized features of renewable energy schemes in many developing countries, the use of biomass technologies for electricity generation is grossly underdeveloped and underutilized [63]–[65]. This is evident from the contribution of biomass to the global renewable share in 2016. Bio-energy only accounted for about 5.5 % (109,731 MW) of the total renewables contribution (2,006,202 MW) to the global power plant mix in 2016 [66]. Presently, efforts are being geared towards the use of bio-energy for HRES in electricity generation; more specifically, forest wood may soon be explored as a prospective candidate [2]. If well subsidized and supported with enabling forest control policies and strong political will, bioenergy can be a major source of power generation in sub-Saharan Africa with vast agricultural activities and forest.

Biomass gasifier is a full-fledged technology which is already being used for electricity generation mostly in rural communities. The gasification process usually involves drying of feed stock (between 100-150 degrees), pyrolysis (between 200-500 degrees), combustion and cracking (between 800-1200 degrees) and reduction (between 650-900 degrees) [67]. The power generated by a biomass gasifier is dependent on the availability of the feedstock, and the daily generator operating hours. The power output of a gasifier is mathematically represented by [68]:

$$P_{bmg} = \frac{\text{available biomass (tons/year)} \times CV_{bmg} \times \eta_{bmg} \times 1000}{356 \times \text{operating hours per day}} \quad (1)$$

where CV_{bmg} , and η_{bmg} are the calorific value of biomass and overall conversion efficiency of the entire gasifier system respectively.

B. SOLAR ENERGY

Solar energy is the radiant energy from sunlight. The global solar irradiation is one of the major prospects that can tremendously increase the global renewable energy share and reduce emission of GHGs. The potential of using solar energy is very vast and abundant in Africa and as such a solar generating facility occupying approximately 0.3% of the land mass in north Africa has the potential to meet all the energy demand of the European Union countries [9]. However, it is worth noting that the quantity and time duration of solar irradiation received varies across the world. These values also vary across regions in a particular country. For example in South Africa, the north-western locations receive more solar irradiation as compared with the southern and north-eastern cities (Figure 5). As a result of this, the technical and economic viability of solar power plants differ across a particular geographical location.

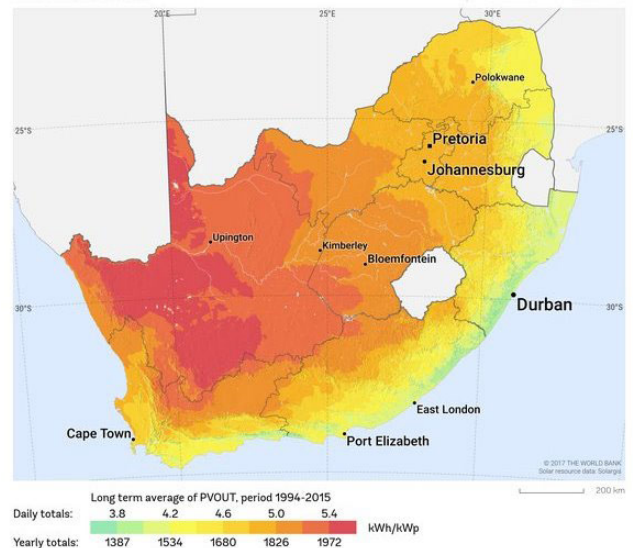

FIGURE 5. Global horizontal solar irradiation (GHI) map of South Africa, Lesotho and Swaziland [71].

Solar radiation can be converted to energy in two broad ways: active and passive solar design. Active solar designs are concerned with the conversion of solar irradiance to heating or for electricity generation. Passive solar system design focuses on maximization on the sun energy for optimal design of a building [69]. In the passive solar design, buildings are designed to maximize sunlight during the day (sun hours) so as to reduce the needs for artificial lighting and heating. Some of the technologies developed for harnessing solar resource for heating and electricity generation include: linear Fresnel reflector, parabolic trough collector, parabolic dish collector, central tower receiver and solar PV [70].

Solar energy is intermittent in nature and the duration of its availability is location specific. Therefore, to effectively utilize solar resources for electricity generation, conventional power generators and/or energy storage systems are essential. In other cases, other renewable energy sources can be integrated. One major challenge of energy conversion from solar resources to electricity is that the efficiency is typically low. PV development is a physical process in which solar energy is transformed directly into electrical energy. The power output of a PV panel can be obtained using:

$$P_{pv} = Y_{pv} f_{pv} \left(\frac{\overline{G_T}}{G_{T,STC}} \right) [1 + \alpha_{pv}(T_c - T_{c,STC})] \quad (2)$$

where Y_{pv} is the rated capacity of PV array, f_{pv} is the PV derating factor (per cent), $\overline{G_T}$ is the solar irradiation incident on the PV array (kW/m^2), $G_{T,STC}$ is the solar irradiation incident at standard condition ($1 kW/m^2$), α_{pv} is the temperature coefficient of power (per cent/ $^{\circ}C$), T_c is PV cell temperature ($^{\circ}C$) and $T_{c,STC}$ is the PV cell temperature under standard test conditions ($^{\circ}C$).

If the effects of temperature are neglected, the resulting expression is used for estimating the output of a PV solar panel:

$$P_{pv} = Y_{pv} f_{pv} \left(\frac{\overline{G_T}}{\overline{G_{T,STC}}} \right) \quad (3)$$

C. WIND ENERGY

Wind energy is the energy obtained by converting the kinetic energy in wind into electricity via a wind turbine. Wind energy is one of the most promising and fastest growing renewable energy worldwide. This can be attributed to the presence of wind resource in many parts of the world and various technological breakthroughs with respect to the design of wind turbines. These technological breakthroughs have also led to reduction in the investment cost and the cost of energy from a wind turbine [72]. Emerging trends due to the advancements in wind energy include development of off-shore wind farms, grid-tied on-shore wind farms and small scale off-grid wind turbines. Although research efforts are on-going on the development of new approaches to obtain optimal power from wind turbines, the fact still remains that the output from wind turbines is stochastic in nature due to the intermittent nature of the wind [73]. Just like solar energy, a wind turbine for electricity generation is not technically and economically feasible for all geographical areas. Offshore locations and locations on high altitude are mostly favored for siting of wind farms [74], [75].

At present, some developed countries such as Canada [76], Denmark [77] and USA [78] and developing countries like China, South Africa, Brazil and India already have wind turbines integrated onto their national grids. In order to further increase wind energy share across the globe, governments of various countries need to put in place appropriate subsidies, feed-in-tariffs, tax exemption on wind energy products, and subsidized cost of energy. Policies that compel utilities on the minimum level of energy from wind resource can also help in increasing wind energy penetration.

The power output from a wind turbine is dependent on the turbine blade size, wind density of the surrounding air and the wind speed. Before a wind turbine can be sited for electricity generation, it is important to carry out an assessment analysis to obtain the maximum obtainable power. This is what will determine the economic viability (payback period) of such investment [79]. It is, therefore, important that before siting a wind farm, a wind map showing the available wind resource and suitable turbine systems for a particular geographical location is made available.

Because of the good approximation provided by the two-parameter Weibull distribution function, it is usually used in characterizing wind regimes. The probability density function used to represent wind speed is represented by the following equation:

$$f(v, k, c) = \left(\frac{k}{c}\right) \left(\frac{v}{c}\right)^{k-1} \exp\left[-\left(\frac{v}{c}\right)^k\right] \quad (4)$$

where v is the wind speed, k is the Weibull shape factor, c is the Weibull scale parameter.

The output of wind energy system depends on the rated speed, power rating of the turbine (P_R), cut-out speed, and cut-in speed. The power output from a wind turbine system can be estimated using:

$$P_{out} = \begin{cases} 0 & \text{for } 0 \leq v < v_{ci} \text{ and } v > v_{co} \\ av^3 + bP_R & \text{for } v_{ci} \leq v < v_R \\ P_R & \text{for } v_R \leq v \leq v_{co} \end{cases} \quad (5)$$

$$a = \frac{P_R}{v_R^3 - v_{ci}^3} \quad (6)$$

$$b = \frac{v_{ci}^3}{v_R^3 - v_{ci}^3} \quad (7)$$

where v_R, v_{ci}, v_{co} are the wind turbine rated speed, cut-in speed and cut-out speed respectively.

The height at which the wind turbine is installed has a substantial influence on the total energy that can be obtained at a particular location. In order to accommodate the effects of change in height at which the blades of the wind turbine are placed, the famous Power Law is usually applied:

$$\left(\frac{v}{v_{ref}}\right) = \left(\frac{H}{H_{ref}}\right)^\beta \quad (8)$$

where v is the wind speed at hub height H , v_{ref} is the wind speed measured at the reference height H_{ref} and β is the power law exponent which varies with the elevation, the time of day, the season, the nature of the terrain, the wind speed and the temperature [80].

IV. OPTIONS FOR STORAGE TECHNOLOGIES

In order to improve the availability of HRES services, it is essential to introduce a backup device. This will help to avoid/reduce the effects of intermittency of some renewable energy sources (e.g. wind and solar). This could be achieved through the use of backup generators and energy storage devices. Energy storage devices are an essential part of a HRES because of their ability to store energy in times of abundant energy from the renewable resource(s) and use them to offset in times of deficit. Therefore, energy storage system (ESS) ensures that the mismatch between energy demand and supply is canceled out to avoid both technical and economic negative effects. Usually off-grid energy systems are designed to have energy storage systems which are connected to the renewable energy sources through power electronic devices which monitor and control the power flow in and out of the storage system. ESSs are usually used for smoothing fluctuations, providing flexibility, peak shaving, and for providing fast response in times when other sources of energy are out [81]. A typical example of a sector where the importance of ESS is evident is a remote community where spikes are usually noticed on the load pattern during the evening periods. If these spikes are to be met by conventional generators, it may result in excess capacity

which will increase the system cost and consequently the cost of energy. The integration of energy storage into such systems helps in shaving the spikes and eliminates demand deficits.

Figure 6 shows energy generation management with and without energy storage [82]. The ESSs generally operate in 3 modes viz: charging, storage and discharging (Figure 7). In the charging mode, the energy produced by the energy sources usually exceeds the demand and so there is excess energy that can be stored for future use. During discharge, the stored energy is used to supply the energy demand that is not met because of deficit from all the other power sources. Usually, the storage system is not allowed to discharge beyond a particular level called maximum depth of discharge. Figure 7 gives the two taxonomies of ESSs categorization based on time frame, and categorization based on storage medium. Details of these are available in the literature [10], [47], [83], [84].

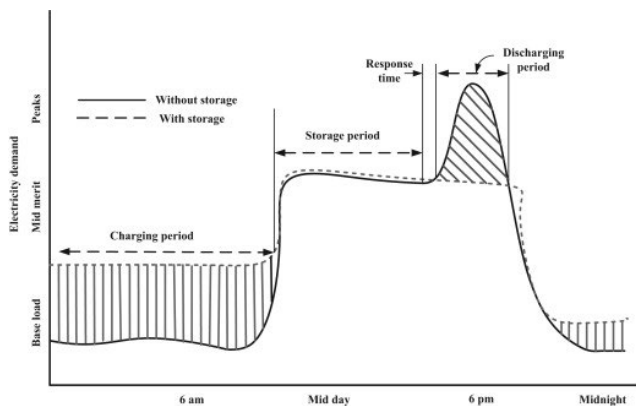

FIGURE 6. Power generation management with and without ESS [82].

V. SOLAR PV-WIND TURBINE HRES

The major aim of hybridization of energy systems is to compensate for the various drawbacks exhibited by individual energy systems. The most common HRES configuration is one in which one or more renewable energy sources is combined with a fossil-powered generator and/or energy storage system to supply the energy demand. For instance, output of a hybrid off-grid solar PV panel and wind turbine (PV/WD) is more reliable than operating them individually to power a load [29]. However, to maximally utilize the renewable energy resources and avoid mismatch between energy demand and supply, the addition of ESS is inevitable. The addition of fuel cells and diesel generators can also be used to provide the required power balance and eliminate or minimize the mismatch. In this review, attention is given to hybrid PV/WD HRES. This is because they are the most common renewable energy sources commercially available at both large and small scale. The PV/WD HRES can be adopted by utility companies for grid connections and as off-grid power plants for low-income earners with the intention of powering

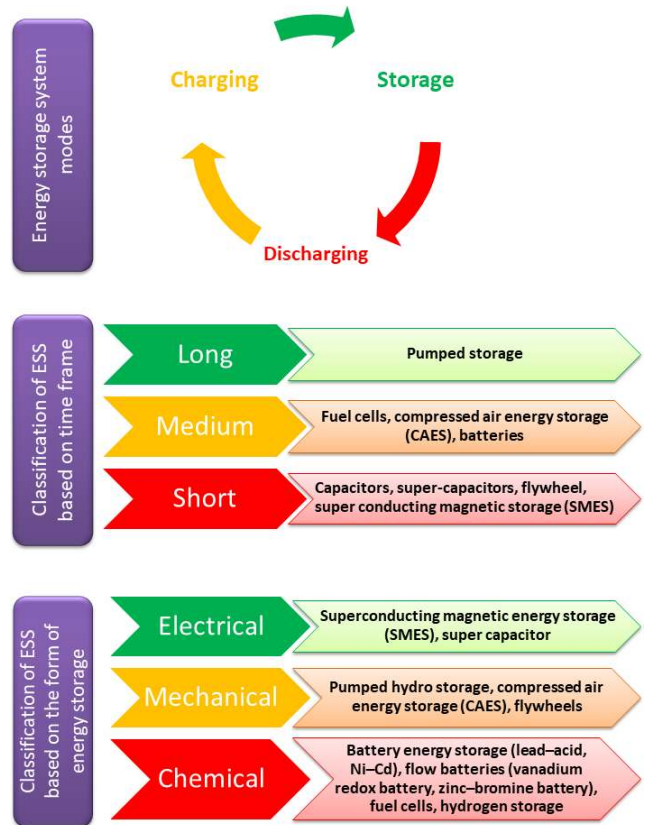

FIGURE 7. Energy storage modes and classifications [85], [86].

few kW of load. Shown in Figure 8 are the possible arrangements of a typical PV/WD system (PV/WD, PV/WD/ESS, PV/WD/ESS/other renewables, PV/WD/ESS/ Fossil sources, PV/WD/ESS/other renewables/fossil sources). The systems can be coupled on a DC-bus AC-bus or Dual bus. These connections are achieved through the use of various power electronics devices (converters). The next subsection presents a discussion on the various topologies for connecting PV/WD HRES.

A. COUPLING TOPOLOGIES

1) DC BUS-CONNECTED PV/WD HRES

In this topology, the DC output from the PV is connected to the DC bus through a DC-DC electronic converter, while the output from the wind turbine is connected to the DC bus using an AC-DC electronic converter. The ESS is coupled to the DC bus using a bi-directional converter to allow for the charging and discharging. This type of configuration is typically designed to serve DC loads but in the event that an AC load needs to be served, a DC-AC converter is required. Thus, this topology can serve both AC and DC loads simultaneously. Fossil fuel-powered generators and other sources of renewable energy can also be connected using the appropriate electronic converters. A major advantage of this topology is its simplicity and elimination of challenges associated with

PV/WD	PV/WD/ESS	PV/WD/ESS/ Other RES	PV/WD/ESS/ Fossil sources	PV/WD/ESS/Other RES/Fossil sources
<p>Description</p> <p>Wind and solar resources are intermittent in nature and they depend on the fluctuations on hourly weather forecast. This makes their individual outputs unreliable over a 24 hour period. By implication, a single source (PV panel or wind turbine) may not supply the sufficient power that is necessary to satisfy a connected load. Apart from this, single source energy system of PV or wind is not cost effective and in most cases not economically viable. The integration of both sources increases reliability and sustainability.</p>	<p>Description</p> <p>PV/WD/ESS is the most widely used and investigated HRES for standalone applications because of its high reliability especially in remote communities. Combining ESS with PV and wind turbine eliminates the challenge of power fluctuations experienced through the use of off-grid PV/WD system only. When compare to other forms of HRESs (WD/ESS, PV/ESS, PV/WD), PV/WD/ESS is more economical for off-grid electrification. Some of the available ESS technologies used in this configuration include hydrogen tank, battery bank, flywheel, pumped hydro, super capacitor etc.</p>	<p>Description</p> <p>In this configuration, other renewable energy sources such as biogas (BG), Pico-hydro (PH), biomass (BM), fuel cell (FC) electrolyzer (EL), hydrogen tank (HT) etc., are integrated with PV panel and wind turbine to supply the load. Based on the available resources in a particular location, various nomenclatures of PV/WD/ESS/Other RES are obtainable. Some of them include: PV/WD/BG/BM/ESS, PV/WT/BG/BM/HG/ESS, PV/WT/BM/ESS, PV/WT/FC etc.</p>	<p>Description</p> <p>This configuration combines PV/WD energy system with fossil fuel-powered captive generators and energy storage system. The most common form of the system is the PV/WD/ESS (battery) combined with a gasoline or diesel generator. Although this form of HRES generates emissions, it ensures that electricity is available at all times. The fossil powered generator attached to this configuration only comes online when the outputs from the PV panel and wind turbine are not sufficient to satisfy the load demand. This process ensures that fossil powered generator runs for less hours and there is reduction in emissions</p>	<p>Description</p> <p>This configuration integrates PV, WD, other renewable energy sources, fossil fuel-powered generators and storage devices. Due to the investment, operations and maintenance costs, this type of HRES is uncommon especially for small scale off-grid applications. However, depending on the location of the HRES and as the demand to be met increases, it may be cost effective. Examples of such configurations include: PV/WD/DG/BG/ESS, PV/WD/DG/BM/ESS, PV/WT/FC/DG/ESS, PV/WT/BM/HG/ESS etc.</p>

FIGURE 8. PV-wind HRES configurations.

synchronization. However, a failure of the DC-AC converter on the demand side results in the loss of the AC loads.

2) AC BUS-CONNECTED PV/WD HRES

The AC bus-connected PV/WD HRES consists of the PV panel connected to an AC bus through a DC-AC electronic converter and a wind turbine connected to the AC bus using an AC-AC electronic converter. Just like the DC-coupled PV/WD HRES, the ESS is connected through the use of a bi-directional electronic converter. AC loads are supplied directly from the AC bus while DC loads are supplied through an AC-DC converter. Conventional generators and other sources of renewable energy can be connected through the use of suitable electronic converters. This particular topology has a very vast application in both rural and urban areas for both large scale and small scale purposes (household, community, industrial, commercial). A major challenge of this topology is synchronization.

3) DUAL BUS-CONNECTED PV/WD HRES

The dual bus-connected PV/WD HRES topology uses the AC and DC bus. This topology ensures that renewable energy sources with AC outputs are directly connected to the AC bus while renewable energy sources with DC outputs are directly connected to the DC bus thereby reducing the number of converters and limiting power losses due to conversion [29], [87]. Consequently, dual bus-connected PV/WD HRES increases overall system efficiency while at the same time reducing cost as compared to HRES with single bus. This HRES topology is flexible and able to combine energy sources and load no matter their features [32], [88]–[98]. Based on these reasons, the most widely adopted PV/WD HRES topology is the dual bus-connected configuration. The major bottleneck in the adoption of this topology is the complexities that arises from the control and management of the system. It is worth noting that, there is no universal scheme with regards to renewable energy sources combination and their topology.

The best combination and topology are usually application and location specific. Some of these combinations are given in Figure 9.

B. HRES CONTROL STRATEGIES

The continuous interaction between the energy sources (renewables, storage devices and conventional sources) in a HRES and the load may lead to challenges related to power quality, voltage regulation, stability, frequency and dispatch strategy. In order to guarantee reliability, proper coordination and optimum operation in a HRES, a control strategy that ensures energy flow management is required. Apart from increasing the reliability of the system, a good control strategy also promotes cost effectiveness. The control/energy management strategy regulates and allocates active and reactive output power obtained from individual power sources and maintains the frequency and voltage of the HRES at the anticipated level. The control strategies with respect to energy management system in a HRES can be classified as centralized, distributed or hybrid control strategy. For each classification, each energy source connected to the central bus has its own localized controller that regulates the optimal operation of the unit based on instantaneous information.

The centralized control strategy is structured such that the individual energy sources (including energy storage devices) are connected to their individual local controller (slave) and these local controllers are connected to a central controller called the master controller (Figure 10). The master controller is operated in closed loop with the local controllers. This means that all measurements detected by the local controllers are forwarded to the master controller for adequate decision. Decisions are taken based on the overall objectives and restrictions set by the designer. This means that the master controller serves as the main energy coordinator. One of the disadvantages of this scheme is that it is computationally cumbersome and may likely suffer from single point

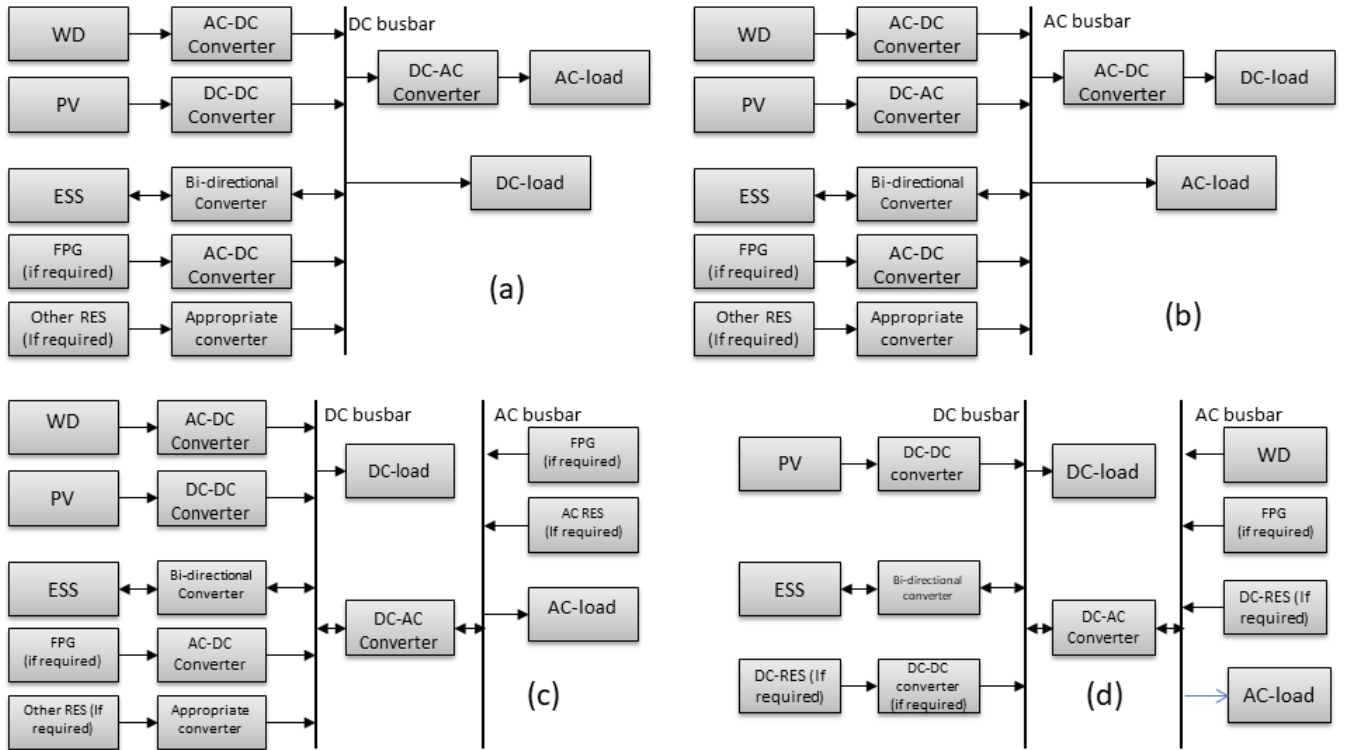

FIGURE 9. Solar PV-wind hybrid renewable energy topologies (a) DC-bus connected (b) AC-bus connected (c) dual-bus connected type 1 (d) dual-bus connected type 2.

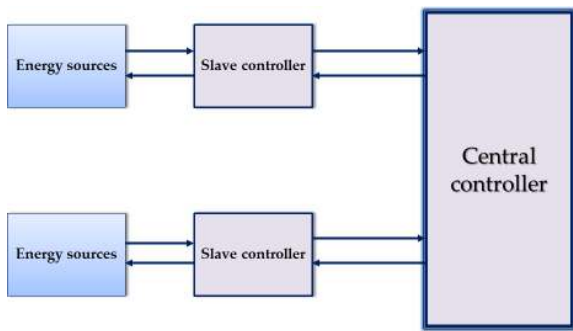

FIGURE 10. Centralized control topology.

based on the specified objectives. One of the advantages offered by a distributed control scheme is that the computational burden is reduced and does not suffer from single point failure [87], [99]. This method however suffers from complex communication among slave controllers [87], [99]. The hybrid control architecture combines the arrangements of both centralized and distributed control strategies (Figure 12). This scheme clusters the energy sources with similar features within the energy system and connects them to a slave controller [99], [100]. The resulting arrangement is then connected to master controllers which are arranged to communicate with each other. This means that

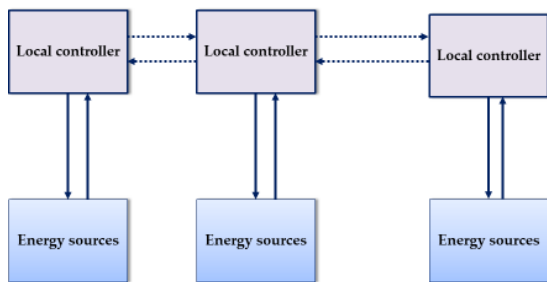

FIGURE 11. Decentralized control topology.

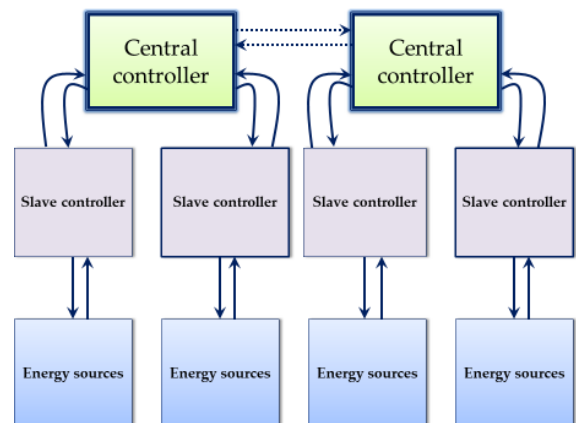

FIGURE 12. Hybrid control topology.

failures [87]. On the other hand, the distributed control configuration does not have a master controller (Figure 11). Rather, the local controllers of the individual energy sources communicate with each other to make informed decisions

the centralized control configuration is adopted within each group of similar energy sources while the distributed control is used for communication among the clusters. As such, local optimization is achieved through the centralized control while global optimization is achieved through distributed control [30]. Based on this, the hybrid control scheme reduces overall computational burden.

VI. BENEFITS OF HRES ADOPTION

A. ENERGY SYSTEM DECARBONIZATION

One of the major benefits of adopting HRES is that, it encourages increased penetration of renewable energy sources thereby encouraging decarbonization of the electricity market. With increased advancements in wind, solar and energy storage technologies, it is expected that future global energy mix will be highly dependent on renewables. This is expected to reduce the emissions and the effects of climate change. Apart from this, it helps in ensuring sustainability in energy production and consumption.

B. CONTINUOUS POWER SUPPLY AND IMPROVED RELIABILITY

The use of single intermittent renewable energy source for electricity production in most cases does not guarantee adequate reliability in terms of availability. This is due to variations in daily weather patterns. For instance, the performance of a standalone solar PV for water pumping will be reduced in days of low solar irradiation (cloudy conditions) and totally non-functional at night. In order to increase the performance of such energy systems, the integration of other renewable energy sources and a storage facility is usually encouraged. If optimally sized, the system's overall reliability increases and the life cycle cost also reduces. HRES, therefore, has the capacity to offer constant electricity without interruption because other conventional generator, energy storage system and/or other renewable energy sources are integrated together.

C. INNOVATIVE ADVANCEMENTS IN THE POWER ELECTRONIC INDUSTRY

Since HRES requires the integration of a different source of energy to provide electricity to various types of loads, adequate coordination between the sources and the loads is very essential for optimal performance. Unlike the conventional power generators which supply their rated power as soon as they are used to power the loads, HRES requires adequate load management for cost effectiveness and high efficiency. In order to achieve these performances, power electronic converters are needed. The need for adequate coordination between the sources and the loads connected in HRES, has also led to the development and innovative advancement in the power electronic industry. The power electronics industry has produced outstanding breakthroughs with respect to the energy conversion, monitoring as well as complex control algorithms that manage HRES [101].

For example, in order to obtain maximum obtainable energy output from a PV panel in a HRES, the use of a sun tracking device such as maximum power point tracking will be required [102]–[106].

D. AFFORDABLE RURAL ELECTRIFICATION

In many developing countries, the issue of rural electrification is of major concern. Electricity access in many remote communities in developing countries is very low and as such majority of rural dwellers lack access to affordable electricity. This is a form of energy poverty. This is predominant in sub-Saharan Africa where the electricity access rates is less than 50% [3], [107]. In such regions, extension of the grid system to rural areas is most of the times not economical because of the difficult terrains and the number of few consumers available to be electrified. It will not be cost effective for the utility companies to extend the grid to areas with a small number of consumers and if the extension is done, the tariff will be too high for the consumers to pay, thereby precipitating low connections and energy poverty. Recent studies and projects have elucidated the use of renewable resources-based distributed power generation for cost-effective electrification of such communities [108]–[112]. Under such schemes, renewable energy sources are hybridized with conventional energy sources and energy storage systems.

VII. PERFORMANCE EVALUATION OF SOLAR PV-WIND TURBINE HRES

A. INPUT REQUIREMENTS

The input requirements for the optimal sizing of a solar-PV-wind turbine HRES can be categorized into meteorological or resources, economic, technical, and load demand.

1) RESOURCE

For a typical solar PV-wind turbine HRES the meteorological/resource data needed include the solar irradiance measured in $\text{kWh}/\text{m}^2/\text{day}$, and the wind speed (m/s). If the effect of temperature on the PV panel is to be included in the model, then obtaining the corresponding ambient temperature for the area under consideration is also very important. If other sources of energy (e.g biomass, hydro, captive fossil powered generator) is/are to be integrated, then details of their corresponding resources must also be obtained.

2) ECONOMIC

The economic input requirements are one of the major factors that will determine the economic feasibility of the final optimized HRES. Some of these include the investment cost (cost of purchasing the individual system components), operations and maintenance costs, replacement costs as well as penalty costs.

3) TECHNICAL

With respect to technical input requirements, the capacities and operational details of the wind turbines, PV panel, battery and other connected system components are very essential.

TABLE 2. Comparison between renewable sources, conventional sources and hybrid renewable energy sources of energy generation.

Description	Renewable energy source only	Conventional generators	Hybrid system
Dependency on natural resources	100%	0%	Partial
Investment costs	High	Low	Moderate
Operation and maintenance cost	Low	High	Moderate
Fuel requirements	None	Consumes fuel depending on connected load	Consumes less fuel due to hybridization with renewable energy sources
Reliability	Relative to the availability of resources. Reliability is lower in intermittent renewable energy	Depends on fuel availability and frequency of maintenance	Reliability is high due to hybridization of renewable energy sources with conventional generators
Frequency of maintenance and repair	Low	High	Low
Load type	Load with few kWh/day	Load with high kWh/day	Load with few, moderate and high kWh/day
Environmental impact	Low	High	Moderate

Other technical details will consist of the constraints that must be added to make the model close to reality. This is usually related to renewable energy fraction and reliability margin. Other technical inputs are those related to the control and management of the entire system and emission conversion factors.

4) LOAD DEMAND

Energy demand (also known as load) is a major determinant needed to obtain the capacities of the individual energy system components. This can either be a DC or AC load. These loads can either be one with high priority or a deferrable load that can be powered when the demand is low. In cases when the load data is not available, an energy audit is carried out and modeled into what is useable by the HRES model. This load data modeling process usually requires that the users and electrical appliances are classified with the number of users of such appliance also obtained. Furthermore, for obtaining the final magnitude of the load, the nominal power of each appliance is used neglecting power cycles. It is also very important to define the period of use of the appliances or equipment (usually over a 24 hour period). An expression for obtaining the energy demand following this process is given in Equation (9).

$$E_d = \sum_{f \in F} N_e \times \left(\sum_{e \in E} N_{ef} P_{ef} t_{ef} \right) \quad (9)$$

where e is the type of equipment/ appliance (lighting, heating, refrigerating, cooling), f is the class (e.g. commercial, agricultural, industrial, educational), N_e is the number of users within class e , N_{ef} is the number of equipment belonging to a specific class, P_{ef} is the nominal electric power rating of an equipment e in class f and t_{ef} is the overall duration of use of each equipment e belonging to class f . The duration of use is usually in minutes or hours.

B. EVALUATION METRICS

Certain performance metrics are used in evaluating the performance of HRES with regards to reliability and viability. These performance metrics are indicators that usually help designers and decision makers to make informed decision in project implementation and policy formulation. Various performance metrics have been applied in the literature to evaluate the performances of HRES. The performance metrics are

broadly classified as socio-political technical, economic, and environmental (Figure 13).

The economic and social metrics are concerned with how affordable the proposed HRES is to all across all income levels. The social and environmental indicators investigate how bearable the optimal system is, while the economic and environmental indicators determine how viable the optimal system is [113]. For sustainability, a balance must be achieved among these indicators. Figure 13 gives a summary of the evaluation metrics for a PV/WD HRES.

C. MULTI-CRITERIA-BASED SELECTION OF SUITABLE

Lack of or inadequate power supply is reported to be one of the major causes of poverty in developing countries [114]–[117]. Access to clean, cheap and sustainable energy is important in motivating sustainable developments in developing countries. It will go a long way in the actualization of the UN's SDGs. It will assist in generation of more jobs, poverty reduction and quality of life improvement. However the size and mix of the optimal system that will encourage sustainable development need to be analyzed in such a way as to ensure that the system is adequately optimized, and effectively utilized.

When selecting an optimal HRES based on a single performance metric, the ranking is usually simple and straight forward. However, when the designer's aim is to design a sustainable system, ranking and selection of a system will be based on multiple criteria and more complex. Thus, it is essential to rank and select HRES based on multiple performance factors when designing and planning small scale energy systems. In the past, optimal renewable energy projects have been appraised based on single criterion some of which includes some of the factors presented in Figure 13 (e.g. life cycle cost, cost of energy, reliability, renewable energy fraction, emission saved). In order to have a sustainable system, it is necessary to consider in details the technical sustainability problems (non-conformity with codes and standards, reliability, capacity outages, management system), economic sustainability problems (impact of state policies, subsidies, access to funding), environmental sustainability (emissions, environmental life cycle assessments, land use) and the socio-political and institutional context. To achieve this, multi-criteria decision analysis (MCDA) methods are very essential [5], [51]. According to [5], "MCDM technique

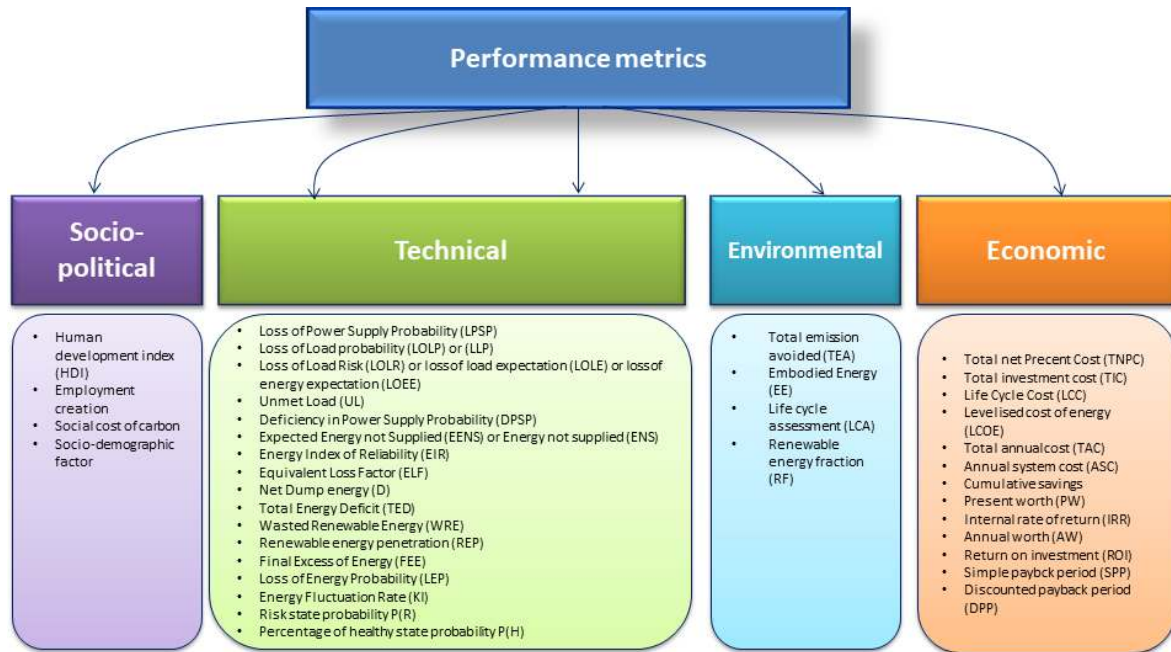

FIGURE 13. Summary of a PV/WD HRES performance metrics.

makes decision based on multiple and conflicting criteria”. It offers a step by step procedure for selecting the most suitable alternative from multiple alternatives based on multiple performance attributes. Details of MCDA methods may be found in the literature [5], [118]–[122].

D. RELIABILITY HANDLING IN HRES MODELING

The main aim of hybridization of power sources is to increase the availability of the entire system. This means a HRES should be able to adequately satisfy the energy requirements of the target customer at minimum net present cost and cost of energy. Oversizing the energy system to adequately meet the energy demand will lead to higher capital cost, operations cost, total net present cost as well as cost of energy while under-sizing will lead to unmet load and unscheduled loss of load that may result in technical challenges, financial losses and unnecessary litigations. Consequently, optimum reliability level must be specified and maintained at all times. In order to set a minimum reliability level in the design of HRES designers use either the technical or economic attributes. This can be introduced as an objective function or as a constraint that must be met. It is therefore essential that HRES are designed to accommodate ... without causing unbearable discomforts to the consumers routine repairs and maintenance, sudden demand increase, resource shortage, changes in operational conditions of the energy sources, forced outages. The issue of reliability in HRES modeling may not be much of a challenge in a small scale system like that used in powering low income households. It however becomes an issue when powering sensitive loads and large scale customers who cannot afford to stay off electric power.

Some of the reliability indices that have been applied in handling reliability issues include: minimum renewable fraction [1], [113], [123], loss of power supply probability [37], [124]–[131], loss of load expectation [132], [133], level of autonomy [134], deficiency of power supply probability [135], minimum annual capacity shortage [136], loss of load risks [132], [133], excess of power generation [135], equivalent loss factor [137], expected energy not supplied [138]–[141].

E. UNCERTAINTY ANALYSIS

In energy system modeling especially HRES, there are several events whose sequence and degree of occurrence are not predictable. These occurrences cause uncertainties that are usually difficult to quantify. Some of these factors are related to economic, political, technical, regulatory, environmental, resources availability, social and climatic (regional) [5], [53]. For instance, HRES are usually designed to last for between 10 and 20 years, this means if a fossil powered generator is added to the configuration, there is likelihood for the price of the fuel to fluctuate. This will definitely affect the life cycle cost of the system as well as the cost of energy. Apart from this, scarcity of fuel may also affect the overall performance of the entire system. The periodic variations in meteorological resource may also cause the technical and economic viability of a HRES to fluctuate. The inclusion of these uncertainties leads to complexities in the mathematical modeling and solution algorithm in terms of computation. Based on information in the literature, uncertainty analysis may be carried out by either scenario analysis, probabilistic analysis, portfolio analysis or sensitivity analysis [142].

These uncertainty handling techniques ensure that the proposed model is robust and flexible [5]. Some of the most common causes of uncertainties in HRES modelling are presented in Figure 14.

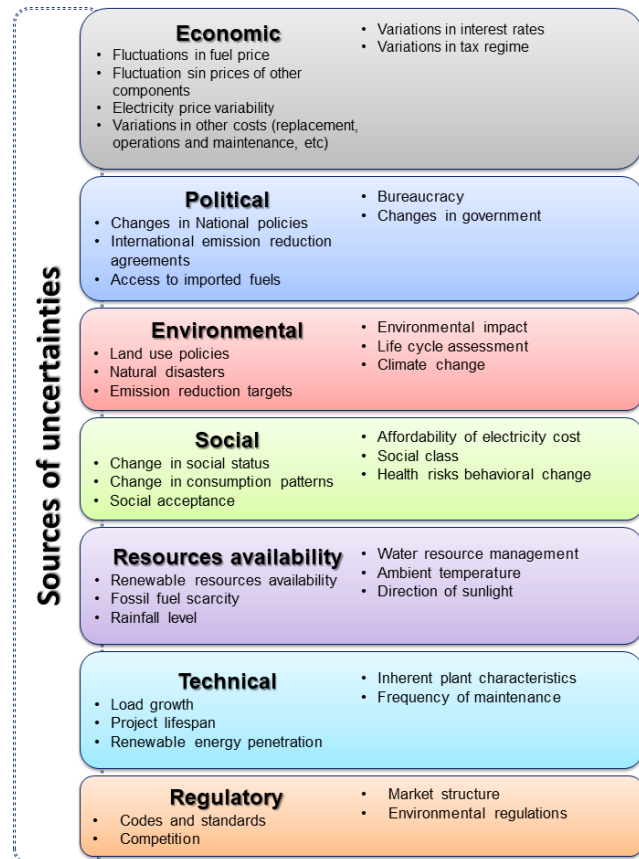

FIGURE 14. Sources of uncertainties in PV/WD HRES.

VIII. SIZE MODELING AND OPTIMIZATION OF HRES

Optimal sizing and modeling of HRES is essential so as to ensure resources are well managed. It is important that the component units are sized optimally to ensure optimum efficiency, adequate availability in terms of reliability as well as economic efficiency. Economic efficiency ensures that the energy system with the minimum total net present cost or minimum cost of energy that can adequately satisfy the consumer energy demand is selected as the most suitable. Since multiple components are usually connected to form a HRES, its technical coordination and financial implications becomes a complex optimization problem because all components must work together under multiple contradictory objectives and constraints. If a HRES is over-sized, the cost of investment and the cost of energy will increase and may be not economically viable. On the other hand, if undersized, the reliability of the system is compromised. Hence, a trade-off through the use of optimization technique(s) is inevitable.

Optimization techniques are algorithms for estimating maximum or minimum values of mathematical functions. Various objective functions may be examined when designing

a HRES. Some of them include: minimization of total costs/ life cycle cost, maximization of reliability, maximization of renewable energy fraction, and minimization of cost of energy. Others include minimization of emissions, maximization of number of jobs created, minimization of imported energy, maximization of profits and so on. Optimization techniques can help in addressing these objectives as well as their associated constraints in order to obtain an optimal HRES configuration. Generally, the main objective considered in HRES sizing, modeling and optimization is minimization of associated costs and maximization of reliability [29]. The broad optimization process for HRES is given in Figure 15. Various optimization techniques have been applied in the sizing and modeling of HRES. These techniques can be grouped into classical optimization techniques, meta-heuristics, hybrid techniques, and commercially available software.

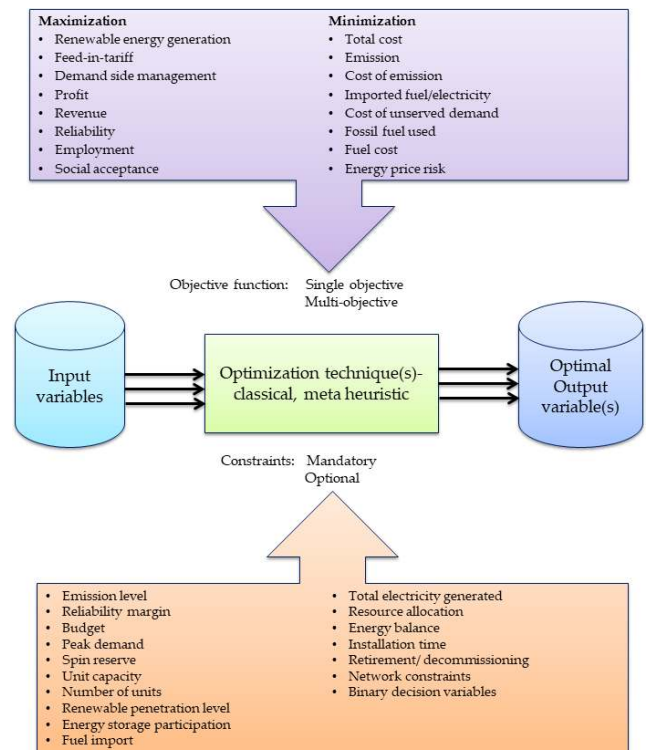

FIGURE 15. Optimization process for HRES sizing.

A. CLASSICAL OPTIMIZATION TECHNIQUES

Generally, classical optimization techniques are used in finding best solutions of differentiable and continuous functions. In order to obtain the optimal solution for a particular function, classical optimization techniques use differential calculus. According to Babatunde et al., “This approach has the tendency to handle three types of problems: single variable function, multivariable functions with both equality and inequality constraints, and multivariable functions with no constraints” [5]. Although it has been extensively used in obtaining solutions to optimization problems involving the design

of HRES, one of the drawbacks of classical optimization techniques is that it cannot obtain solutions to functions that are non-differentiable and/or non-continuous [5], [29], [143]. Some of the classical optimization techniques that have been used in the modeling and optimization of HRES includes: linear programming (LP) [144]–[149], dynamic programming (DP) [150], [151], Quasi-Newton algorithm [152], non-linear programming (NLP) [152], [153], branch and bound (BB) [154]–[157]: process graph (p-graph) [158], Generalized Reduced Gradient (GRG) [155], multi-objective programming (MOP) [159], [160], Dantzig-Wolfe decomposition (DWD) [161] multi-objective goal programming [162], Quadratic programming [163], [164] analytical method [132].

B. META-HEURISTIC OPTIMIZATION TECHNIQUES

Majority of practical optimization problems consist of non-linearities, non-convexities, discontinuities, conflicting multiple objectives, constraints as well as mixed variables. A combination of these features makes practical search and optimization problems complex with enormous dimensions. These kinds of optimization problems are usually difficult and sometimes impractical to solve using classical optimization techniques. It is reported that no classical optimization technique has been reported to provide optimal solutions to non-differentiable optimization problem with cost effective and fast computational time [5], [165]. In order to obtain solutions to such complex optimization problems, heuristics algorithms have been developed and tested. Although not based on sound mathematical backgrounds, such methods have been reported to provide approximate solution in reasonable computational time [5]. The term approximate connotes that solutions obtained through these medium are inexact but near-optimal solution in a computationally efficient way. Due to computational efficiency, simplicity of implementation as well as the ability to handle complex optimization problems, many meta-heuristic techniques have been implemented to provide solution to optimization problems involving the sizing of HRES. Most of the meta-heuristic optimization techniques are based on mimicking biological, physical or natural principles and exhibit stochasticity. A comparison between classical optimization and meta-heuristic optimization techniques indicates that global optimality is not guaranteed for the solution provided by the latter [5]. In order to obtain a solution, meta-heuristic optimization techniques perform a search of the solution space of the problem to find near optimal solutions using a set of logical or empirical rules based on either social behavior, natural, biological, or physical occurrences [166]–[168]. Examples of meta-heuristic optimization techniques that have found applications in use for HRES modeling and design include simulated annealing (SA) [169], particle swarm optimization (PSO) [170]–[178], genetic algorithm (GA) [170], [179]–[187], ant colony (AC) algorithm [188]–[191], fruit fly optimization algorithm (FAO) [192], artificial bee colony (ABC) [193]–[197],

artificial bee swarm (ABS) [198], Cuckoo Search algorithm [97], [170], discrete harmony search (DHS) [199], biogeography based optimization (BBO) [200]–[202], imperial competitive algorithm (ICA) [203], mine blast algorithm [204], brain storm optimization (BSO) [205].

C. HYBRID OPTIMIZATION TECHNIQUES

In order to obtain quality solutions, achieve simplicity of implementation and computational efficiency, existing optimization techniques are being combined for solving optimization problems. These resulting methods are called hybrid optimization techniques. Hybrid optimization techniques combine two or more single heuristics and/or classical optimization techniques by exploring the advantage of the individual methods. Various hybrid optimization techniques have been implemented for the design and modelling of HRES in the literature while there are more possibilities of exploring the combination of other optimization techniques in HRES design and modeling (Figure 16). The green shade shows the hybrid optimization techniques that have already being implemented, the orange shades show potential hybrid optimization models while the red shade cannot be implemented. Figure 16 shows that the most hybridized optimization model is GA followed by PSO.

	PSO	CSM	EST	MOEA	ANN-MCS	TA	Markov	HS	IM	SA
BB-BC	Green	Orange	Orange	Orange	Orange	Orange	Orange	Orange	Orange	Orange
TLBO	Orange	Green	Orange	Orange	Orange	Orange	Orange	Orange	Orange	Orange
GA	Orange	Orange	Green	Green	Green	Orange	Green	Orange	Green	Green
SA	Green	Orange	Orange	Orange	Orange	Green	Orange	Green	Orange	Red
Monte Carlo	Green	Orange	Orange	Orange	Orange	Orange	Orange	Orange	Orange	Orange
FPA	Orange	Orange	Orange	Orange	Orange	Orange	Orange	Orange	Orange	Green

FIGURE 16. Existing and proposed hybrid optimization approaches in HRES sizing (BB-BC-bang-big crunch, TLBO-teaching-learning-based optimization algorithm, GA-genetic algorithm, SA-simulated annealing, FPA- flower pollination algorithm, PSO-particle swarm optimization, CSM- clonal selection method, EST- exhaustive-search technique, MOEA-multi-objective evolutionary algorithm, ANN-MCS- artificial neural network-Monte Carlo simulation, TA-tabu search algorithm,HS-harmony search, IM- iterative method).

D. COMMERCIALY AVAILABLE SOFTWARE

Besides the classical, heuristic and hybrid optimization techniques available for the design and sizing of HRES, there are also many commercially available user-interface friendly software that are accessible for the design, modeling and sizing of various aspects (size and economic optimization, control, uncertainty analysis, environmental analysis) of HRES. Some of these software are discussed in this subsection. The most widely used commercially available HRES design

software by both academia and decision makers is HOMER. HOMER, a software designed by the National Renewable Energy Laboratory (NREL) USA, has the tendency to perform simulations, optimization and uncertainty analysis of HRES [206]. Some of the energy components available in HOMER include wind turbine, photovoltaic panel, battery, fossil powered generators, reformer, biomass, hydro-electric, hydrokinetic, hydrogen tank, electrolyzer, flywheel, converter and loads [206]. The inputs needed in HOMER include control specifications, emission details, component data (technical and economic), system constraints and resources data (meteorological and fuel). Some of the output include; total net present cost, levelized cost of energy, emissions, fuel consumption, renewable energy penetration, capital cost, unmet load, total investment cost, excess energy. HOMER can model both on and off-grid energy systems. Another software designed by NREL capable of implementing HRES is Hybrid2. Hybrid2 is a probabilistic time series simulation model which is user-friendly and can implement comprehensive long term economic and system performance analysis for various HRES components [207]. Improved Hybrid Optimization by Genetic Algorithms (iHOGA) is a HRES sizing software based on C++ designed by researchers at the Department of Electric Engineering, University of Zaragoza [208], [209]. It can simulate and optimize hybrid stand-alone and grid connected energy systems based on renewable energies (wind turbines, PV panels, fuel cell, and hydroelectric turbine). RETScreen is energy management software developed by the ministry of natural resources, Canada [210]. It has the capacity to analyse the techno-economic viability of energy efficiency, renewable energy and cogeneration projects [209], [210]. Other commercially available software includes hydrogen energy model (HYDROGEM) [2], RPSIM (remote area power supply simulator) [2], transient energy system simulation program (TRNSYS) [209], hybrid system simulation models (HYBRIDS) [209], [211], INSEL [2], SOLSI [2], SOMES [2].

IX. SUSTAINABLE HYBRID RENEWABLE ENERGY PLANNING

The need to ensure sustainable energy for all is currently a pressing global issue which has been acknowledged by government and decision makers in both developing and developed economies. As per developed economies, the access rates are usually very high such that many of their rural communities are electrified. However, the problem of electrification is still a major challenge in developing countries especially in Africa. The huge potentials of renewable energy resource in many developing economies if developed can serve as a measure for mitigating low electrification rates [212]. Embracing renewable energy technologies will not only cut down dependency on conventional sources of energy and imported fuels, it will also encourage decentralization of energy systems. With decentralization, the energy system is closer to the consumers and the cost associated with grid extension to remote communities is eliminated [213].

The use of HRES with or without fossil power plants for electrifying off-grid consumers is fast becoming an emerging concept especially in countries with low electrification rates. These technologies are also changing the electricity market in such countries (decentralization of the grid). At the decentralization level, the concept of energy planning involves mapping out or isolating consumers from the grid system and providing an adequate reliable energy resource to them at a cost effective rate and environmentally friendly manner. Depending on the target customer, some of the objectives of decentralization using HRES are reduction of energy cost, improvement in adequacy and reliability as well as electrification of remote areas. Cost effectiveness is achieved by using more of the locally available resource, while reliability is improved by hybridizing the energy systems.

According to the United Nation Development Programme, access to modern, low-cost energy systems for all is important in the realization of the globally agreed developmental goals. This would assist in the reduction of poverty and improvement of the quality of life for the greater part of the world's population. Access to electricity for all, may be achieved in three different ways [214]:

- At the household scale by adopting off-grid energy systems
- At the household community scale where there is a particular off-grid energy infrastructure that powers the community
- At the grid-based level where the existing national grid infrastructure is extended to the community

At the household level, consumers generate their own electricity from locally available resources (usually fossil-powered gasoline generator, battery bank and other renewable energy sources). In order to do this, consumers must know the possible energy option achievable in the proposed location, analyze the total demand to be served (including short term load increase) and size the energy system taking into consideration all relevant regulatory standards locally available. In remote locations, a particular household may extend excess electricity generated from their own energy system to neighboring households who may be willing to pay. In developed countries, consumers in grid connected areas are usually encouraged to sell excess electricity to the grid [215]. Consequently, such consumers must decide if they will operate their energy production facility as off-grid or grid connected systems.

It is estimated that about 2 billion people are resident in rural communities across the world and without access to electricity [216]. This figure is particularly high in rural communities in developing countries. Many of these communities are characterized by sparse population and difficult terrains which makes grid extension to such communities more expensive and in many cases difficult and impossible. These communities can be electrified using off-grid HRES. The community based energy planning includes powering various small and medium size villages with locally available energy resources.

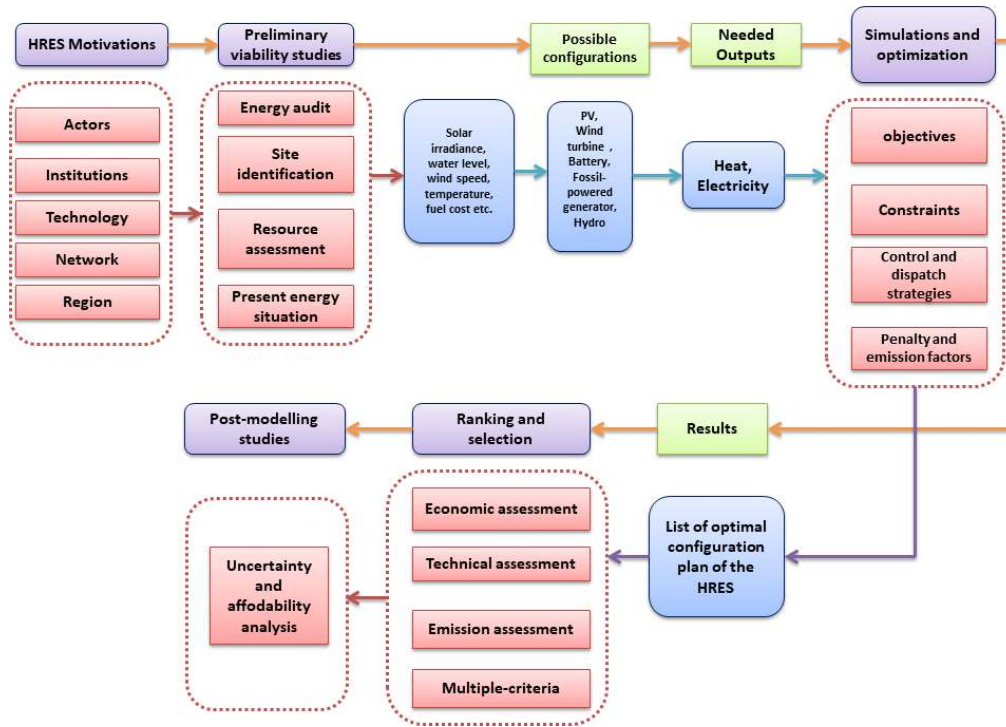

FIGURE 17. Proposed HRES planning framework.

At the grid-based level, the electricity structure is centralized with various power plants (conventional and renewables) participating in the generation of electricity and connected to the national or regional electricity network. The grid is only extended to regions that are economically viable for the utility companies.

HRES planning involves many conflicting objectives and constraints which must work together to produce the desired energy system. It therefore, involves rigorous and strategic planning. The aspect of HRES planning has not been given significant research efforts in the past. This section contributes to this aspect of HRES by proposing a framework that can be used or adapted for comprehensive HRES planning, utilization and informed decision making. The strategic framework can be modified to suit the optimal planning of any specific case study (Figure 17). The foremost step in the proposed framework is the definition of the motivation behind the adoption of a particular HRES. As specified in section 2, these motivations are classified as actors, institution, technology, network and region and may include economic (profit or minimum cost of energy generation, incentives), energy and environmental policies, technological advancements, resource availability. These motivations will define the type of system to be adopted, its size, budget and viability. The next stage involves a preliminary viability study to estimate the energy demand to be served, the possible energy mix, the present sources of energy in the region of target, the present power system capacity available, the various constraints, the output (electricity or heat). For consumers

without distinct load profiles, energy audit will be done to build an approximate load profile. After the preliminary studies have been carried out, it is essential to determine the optimal HRES based on the available resources, the specified objective(s) and the binding constraints. At this stage, various optimization approaches are usually applied to the resulting mathematical model to obtain the decision variables. The optimization process will give outputs related to capacities, costs and emission level. This stage also specifies the control and dispatch strategies that are applicable to optimal HRES. In the next stage, in order to select/rank the optimal systems, a set of metrics are specified and any system that best meets the specified metrics is selected as the overall best. The optimal system may change based on the selected metrics. In cases where there are more than one criterion, a multi-criteria decision making approach can be applied. Some of these metrics are related to economic (TNPC, LCC, COE, and other profitability indices), technical (capacity shortage, reliability), environmental (renewable fraction, emission, impact on biodiversity). The last stage of the planning is the post selection stage where the affordability analysis and sensitivity analysis of the optimal system is carried out. Once the optimal system is affordable (investment –wise or in terms of cost of energy), it is implemented and the periodic maintenance and system upgrades are carried out.

X. AFFORDABILITY OF HRES

Many energy consumers in remote off-grid communities in developing countries still make use of fossil fuel-powered

generators. In other countries with low electrification rates and unreliable central grid system, consumers are also forced to depend entirely either on gasoline or diesel powered generators for their electricity needs. With the increasing breakthroughs in renewable energy technologies and the abundance of certain renewable energy resources, many energy consumers are now migrating to the use of HRES. This is more cost effective, reliable and emits less GHGs. As a result, the theoretical depth and the discussive length of the technical, economic and environmental aspects of HRES have expanded massively in the past few years. However, as it stands, the cost of implementing HRES is still on the high side and still out of the reach of many prospective users. For example, in Nigeria, most of the available HRES projects are either funded or owned by governments, business organizations or middle and high income earners. Many low-income earners/businesses cannot afford these systems or the electricity generated through this means due to fact that the investment cost or the cost of energy (as the case may be) are still on the high side. Since the aim of item 7 on the UN SDG is affordable and clean energy for all, there is need to also ensure that low-income earners also benefit for the numerous advantages of embracing and adopting HRES. There is a pressing need to promote HRES adoption among low-income earners because a sustainable future cannot be created by neglecting a group of people from having access to clean and affordable energy supply. If HRES will be used as a tool for the decarbonization of the electricity sector in the near future to ensure sustainable consumption, then conscious innovative and investment efforts must be directed at improving parity instead of increasing discrimination among energy users. Generally on the average, a low-income household pays an additional 9.2% on electricity bill in contrast to other average households [217]. Apart from “over-paying”, these sets of consumers are usually more vulnerable to hardship resulting from poor economic conditions. Hence, HRES must be made affordable to low income households, through various economic friendly approaches to reduce investment cost or the cost of energy. This will go a long way in improving the quality of life of low-income earners. Affordability is a socio-economic criterion which is related to the ability and willingness of a consumer to pay (for cost of energy from HRES or to purchase the system) [218]. The ability and willingness of a consumer to pay for or purchase a HRES is usually dependent on the level of annual income.

Some of the strategies that can be adopted to diffuse HRES technologies to low-income earners include: collective discount payment programs, inexpensive tenancies and community HRES installations. However, home ownership and low income level are some of the bottlenecks that limit these strategies. Further strategies that will accommodate both home owners and tenants are therefore needed for HRES adoption to increase among low-income earners. The discount program allows consumers to purchase the HRES components in bulk so as to get discounts on the total cost of procurement. This strategy can be structured in two ways.

Consumers can purchase the HRES components in bulk from the sole distributor or the manufacturers and then employ the services of a single vendor to do the installations. This method will ensure that the consumers get discount on both procurement and installations. In the second method, the consumers purchase the components from a single distributor who gives a certain level of discount but use individual vendors (or help each other) for installation.

Based on their annual income, typically, low-income earners may not be able to afford the outright procurement and installation cost of a HRES. This creates a barrier of having access to cleaner energy. One way to approach this challenge is to implement a model that allows low-income earners to purchase HRES and then pay in installments. Proper legislation for the creation of credit houses (banks) that finance such projects can be of great help. These banks can offer amortized loan to low-income earners at very low interest rates and flexible payment plans to encourage them to procure and install HRES. By doing so, HRES technology is made affordable for low-income earners.

XI. SUMMARY OF STUDIES ON HRES

A. COMPARISON OF PAST STUDIES

The summary of studies that has been conducted with respect to HRES between 2010 and 2020 is shown in Table 3. The comparison is based on optimization approach, energy storage system, reliability, techno-economic perspectives, emission evaluation, multiple criteria assessment, demand side management (DSM) activities, load demand increase (LDI), uncertainty assessment, PV tracking orientation, consumer type, and system configuration. It is evident from Table 3 that the inclusion of DSM, LDI, MCDM, uncertainty analysis and PV tracking has not been extensively considered. The comparison shows that majority of the studies on HRES were carried out in Asia (58%) with Iran and India at the fore front. This is followed by Africa (25%) and Europe (10%). In terms of optimization/modeling tools, the heuristic approach is the most widely used, followed by commercially available software with HOMER contributing close to 100% of this. Due to its robust nature, hybrid optimization approaches are fast becoming a very important tool in HRES sizing and modeling. Community electrification has received more than 50% of the total research attention of the studies compared in Table 3 while residential (single household) accounted for 24% of the total case studies. The most widely studied HRES configuration is the PV-Wind system with energy storage. The rest of the analysis is given in Figure 18.

B. FINDINGS AND DISCUSSION

This section provides the findings and discussion based on the reviewed studies related to the operations and planning of HRES. This review paper has been able to comprehensively discuss important issues that border around drivers and

TABLE 3. Comparison of studies on HRES 2010-2020.

	Optimization approach/tool	ESS	RY	MCDM	EC	TL	EN	DSM	LDI	UY	PVO	CRT	HRES configuration
[13]	HOMER	✓	✓		✓	✓	✓		✓			Community	
[14]	HOMER	✓			✓	✓	✓			✓		Healthcare	PV/DG
[17]	HOMER				✓	✓						Residential	PV/Grid
[36]	HOMER	✓			✓	✓						Community	PV/DG
[88]	MILP	✓			✓	✓		✓				Not specified	PV/WD
[89]	HOMER	✓			✓	✓							PV/WD
[90]	Cuckoo search	✓	✓		✓	✓					✓	Agricultural	PV/WD/Grid
[91]	GA-PSO	✓	✓		✓	✓						Residential	PV/WD
[92]	Iterative analytic algorithm	✓	✓		✓	✓						Pumping system	PV/WD
[93]	POS	✓	✓		✓	✓						Office	PV/WD
[219]	HOMER	✓			✓	✓						Community	PV/WD
[95]	HOMER	✓			✓	✓				✓		Office	PV/WD
[96]	Iterative technique	✓	✓		✓	✓						Residential	PV/WD
[97]	Cuckoo search	✓	✓		✓	✓						Community	PV/WD
[98]	Iterative algorithm	✓	✓		✓	✓						Not specified	PV/WT
[108]	HOMER	✓			✓	✓				✓		Community	PV/WD/ HYDRO/DG
[109]	HOMER	✓			✓	✓						Not specified	PV/WD/ HYDRO/DG
[110]	HOMER	✓			✓	✓	✓			✓		Bank. Residential	
[123]	HOMER	✓			✓	✓	✓			✓		Healthcare	PV/WD/DG
[124]	HOMER	✓	✓		✓	✓	✓			✓		Healthcare	PV/DG
[125]	Evolutionary algorithms	✓	✓		✓	✓						Not specified	PV/WD
[131]	Object-Oriented Programming	✓	✓		✓	✓						Not specified	PV/WD
[135]	Iterative technique	✓	✓		✓	✓						Residential	PV/WD
[136]	HOMER	✓			✓	✓	✓	✓		✓		Community	PV/WD/DG
[137]	PSO	✓	✓		✓	✓						Not specified	PV/WD/Grid
[138]	PSO	✓			✓	✓	✓					Community	PV/biogass/ biomass/ hydro/ DG
[148]	Linear programming	✓	✓		✓	✓				✓		Community	PV/WD/ micro-hydro /biogas/biomass
[149]	Linear programming	✓	✓		✓	✓						Residential	PV/WD
[154]	Branch-and-Bound	✓			✓	✓						Community	PV/WD
[155]	Branch-and-Bound and Generalized Reduced Gradient	✓			✓	✓						Residential	PV/WD
[169]	Simulated annealing	✓			✓	✓						Residential	PV/WD
[170]	Cuckoo search	✓			✓	✓						Not specified	PV/WD
[174]	PSO	✓			✓	✓						Academic building	PV/WD

TABLE 3. (Continued.) Comparison of studies on HRES 2010-2020.

	Optimization approach/tool	ESS	RY	MCDM	EC	TL	EN	DSM	LDI	UY	PVO	CRT	HRES configuration
[175]	PSO	✓			✓	✓						Residential	PV/WD
[176]	PSO	✓	✓		✓	✓						Not specified	PV/WD
[177]	PSO	✓			✓	✓						Community	PV/WD
[178]	PSO	✓			✓	✓						Residential	PV/WD
[179]	GA	✓			✓	✓	✓					Community	PV/WD/grid
[180]	GA	✓			✓	✓	✓					Residential	PV/WD/DG
[181]	GA	✓	✓		✓	✓						Community	PV/WD/biomass/ biogas
[183]	GA	✓				✓				✓			WD/DG
[184]	GA	✓			✓	✓						GSM base station	PV/WD/DG
[186]	GA	✓			✓	✓						Desalination systems	PV/WD
[187]	GA	✓			✓	✓						Academic building	PV/WD
[188]	ACO	✓	✓		✓	✓						Community	PV/WD/DG
[189]	ACO	✓			✓	✓						Residential	PV/WD
[190]	ACO	✓	✓		✓	✓						Residential	PV/WD
[192]	Fruit fly optimization	✓			✓	✓	✓					Community	PV/WD/DG
[193]	Artificial bee colony (ABC)	✓			✓	✓						Community	PV/WD/biomass
[195]	ABC	✓	✓		✓	✓						Community	PV/WD/DG
[196]	ABC	✓			✓	✓						Not specified	PV/WD
[197]	ABC	✓			✓	✓						Not specified	PV/WD/biomass
[198]	Artificial bee swarm	✓	✓		✓	✓						Not specified	PV/WD
[199]	Harmony search	✓			✓	✓	✓					Community	PV/WD/DG
[200]	Biogeography based optimization	✓			✓	✓				✓		Community	PV/WD/DG
[201]	Biogeography based optimization	✓			✓	✓						Community	PV/WD/Hydro /DG
[202]	Biogeography based optimization	✓	✓		✓	✓						Community	PV/WD/DG
[204]	Mine blast optimization algorithm	✓			✓	✓						Community	PV/WD
[205]	Brain Storm Optimization	✓	✓		✓	✓	✓				✓		PV/WD/DG
[220]	PSO-Monte Carlo	✓	✓		✓	✓					✓	Not specified	PV/WD
[221]	Iterative-genetic algorithm	✓	✓			✓					✓	Not specified	PV/WD
[222]	Adaptive Neuro-Fuzzy	✓	✓			✓						Residential	PV/WD
[223]	HOMER	✓								✓		Community	PV/WD/ hydrokinetic /biomass/biogas
[224]	Moth flame optimization and Water-cycle algorithm	✓	✓		✓	✓				✓		GSM base station	PV/Biogas/ pumped-hydro
[225]	Reformed Electric System Cascade Analysis	✓	✓		✓	✓				✓		Community	PV/WD/Grid
[226]	PSO	✓	✓		✓	✓				✓		Community	PV/WD/biomass /biogas
[227]	HOMER	✓			✓	✓	✓			✓		Agricultural	PV/WD/DG
[228]	Grey wolf optimizer	✓	✓		✓	✓				✓		Community	PV/WD

TABLE 3. (Continued.) Comparison of studies on HRES 2010-2020.

	Optimization approach/tool	ESS	RY	MCDM	EC	TL	EN	DSM	LDI	UY	PVO	CRT	HRES configuration
[229]	HOMER	✓			✓	✓						Not specified	PV/WD/DG
[230]	Modified crow search algorithm	✓	✓			✓				✓		Not specified	PV/DG
[231]	Not specified	✓			✓	✓				✓		Not specified	PV/Biogas
[232]	Mixed Integer Linear Programming	✓			✓	✓				✓		Industrial	PV/WD/Grid
[233]	HOMER	✓			✓	✓	✓			✓		City	PV/WD/Natural gas-Boiler/Grid
[234]	HOMER	✓			✓	✓	✓			✓		Desalination systems	PV/WD/DG
[235]	SA-HS	✓			✓	✓	✓					Community	PV/WD/biodiesel
[236]	HOMER	✓			✓	✓	✓			✓		community	PV/WD/Biomass
[237]	Not specified	✓			✓	✓						Not specified	PV/WD
[238]	HOMER	✓			✓	✓	✓					Healthcare	PV/WD/DG
[239]	-Constraint method -Shuffled frog leaping algorithm	✓	✓		✓	✓						Not specified	PV/WD
[240]	Flower pollination optimization	✓	✓		✓	✓						Community	PV/fuel cell
[241]	HOGA and HOMER	✓	✓		✓	✓						Not specified	PV/WD
[242]	Iterative	✓			✓	✓				✓	✓	Agricultural	Solar collector /Biomass /Biogas/ gobar gas
[243]	HOMER	✓			✓	✓	✓			✓		Academic building	PV/DG
[244]	Mixed integer convex programming and horizon optimization	✓			✓	✓						Weather station	PV/WD/DG
[245]	GA	✓			✓	✓				✓	✓	Community	PV/WD
[95]	HOMER	✓			✓	✓				✓		Academic building	PV/WD
[246]	PSO and -constraint method	✓	✓		✓	✓	✓			✓		Community	PV/DG
[247]	HOMER	✓			✓	✓				✓		Commercial	PV/Fuel cell
[248]	Improved bee algorithm	✓	✓		✓	✓				✓		Desalination systems	PV/WD
[32]	TRNSYS	✓			✓	✓	✓					Not specified	PV/WD/Grid
[249]	HOMER	✓			✓	✓						Community	PV/WD/DG
[250]	Non-dominated Sorting Genetic Algorithm	✓	✓		✓	✓				✓		Residential	PV/WD
[251]	HOMER	✓			✓	✓	✓			✓		Community	PV/WD/DG
[252]	HOMER	✓			✓	✓						Community	PV/WD
[97]	Cuckoo Search algorithm	✓			✓	✓				✓		Community	PV/WD
[253]	HOMER	✓			✓	✓						Police control room	PV/WD
[254]	Monte Carlo -PSO	✓			✓	✓				✓		Community	PV/WD
[255]	HOMER	✓			✓	✓				✓		Community	PV/WD/DG
[256]	Genetic algorithm	✓			✓	✓	✓			✓		Community	PV/WD/biomass /biogas
[257]	Receding horizon optimization	✓			✓	✓						Residential	PV/WD/DG

TABLE 3. (Continued.) Comparison of studies on HRES 2010-2020.

	Optimization approach/tool	ESS	RY	MCDM	EC	TL	EN	DSM	LDI	UY	PVO	CRT	HRES configuration
[258]	GA	✓	✓			✓					✓	Community	PV/WD
[259]	HOMER	✓			✓	✓	✓			✓		Community	PV/WD/DG
[260]	HOMER and RETScreen	✓			✓	✓	✓					Community	PV/WD/DG
[261]	HOMER	✓			✓	✓						Academic Building	PV/Fuel cell
[262]	HOMER	✓			✓	✓				✓		Community	PV/WD/DG
[263]	Iterative	✓			✓	✓						Community	PV/WD
[264]	SA-HS	✓	✓		✓	✓						Residential	PV/WD
[265]	HOMER	✓			✓	✓	✓					Community	PV/WD/Gasoline generator
[266]	Matlab/Simulink	✓				✓						Not specified	PV/WD
[267]	Matlab/Simulink /LabVIEW	✓				✓						Not specified	PV/WD
[268]	HOMER	✓		✓	✓	✓	✓					Community	PV/WD/DG
[177]	PSO	✓	✓		✓	✓						Community	PV/WD
[269]	HOMER	✓			✓	✓				✓		Commercial	PV/WD/DG/Grid
[270]	Gravitational Search optimization Algorithm	✓	✓		✓	✓						Not specified	PV/WD
[271]	Mixed integer linear programming	✓			✓	✓		✓				Community	PV/WD/Grid
[272]	HOMER	✓			✓	✓						Community	PV/WD/biomass /biogas/small hydro
[273]	HOMER				✓	✓						Academic building	PV/DG
[274]	HOMER	✓			✓	✓	✓					Community	PV/WD/DG
[275]	GA	✓	✓		✓	✓						Community	PV/Micro turbine
[276]	HOMER	✓			✓	✓	✓					Community	PV/WD/Biomass/ Hydro/DG/Grid
[277]	HOMER	✓			✓	✓	✓					Community	PV/WD
[278]	Not specified	✓	✓		✓	✓						Data center	PV/WD
[279]	HOMER	✓			✓	✓				✓		Community	PV/WD
[280]	Matlab/Simulink Package/Labview	✓			✓							Not specified	PV/WD
[281]	HOMER	✓			✓	✓	✓					Academic building	PV/WD
[282]	HOMER	✓			✓	✓				✓		Community	PV/WD/DG
[283]	HOMER	✓			✓	✓	✓					Industrial, community, residential	PV/WD/DG

ESS-energy storage system.RY-reliability, MCDM-multi-criteria decision making, EC-economic, TL-technical, EN-emission, DSM-demand side management, LDI-load demand increase, UY-uncertainty, PVO-PV tracking, CRT-consumer type

challenges of HRES, benefits of HRES adoption, HRES planning, optimization methods and tools for designing HRES, control strategies in achieving optimal HRES dispatch, uncertainty in HRES, configurations of HRES energy storage systems, and affordability issues in HRES. In remote areas that are off the grid system, single source energy technologies may be able to serve energy needs that are not large nor of priority. As the priority level and energy demand increases,

single source energy technologies are insufficient in meeting energy needs because of low reliability and high investment and running costs. The adoption of HRES cancels out the limitations exhibited by single source energy systems. Based on the reviewed literature, the most widely investigated HRES (between 2010 and 2020) is solar PV-wind-battery system, this is followed by solar PV-wind-fossil fuel-powered generator-battery. PV-wind-battery system is emission free

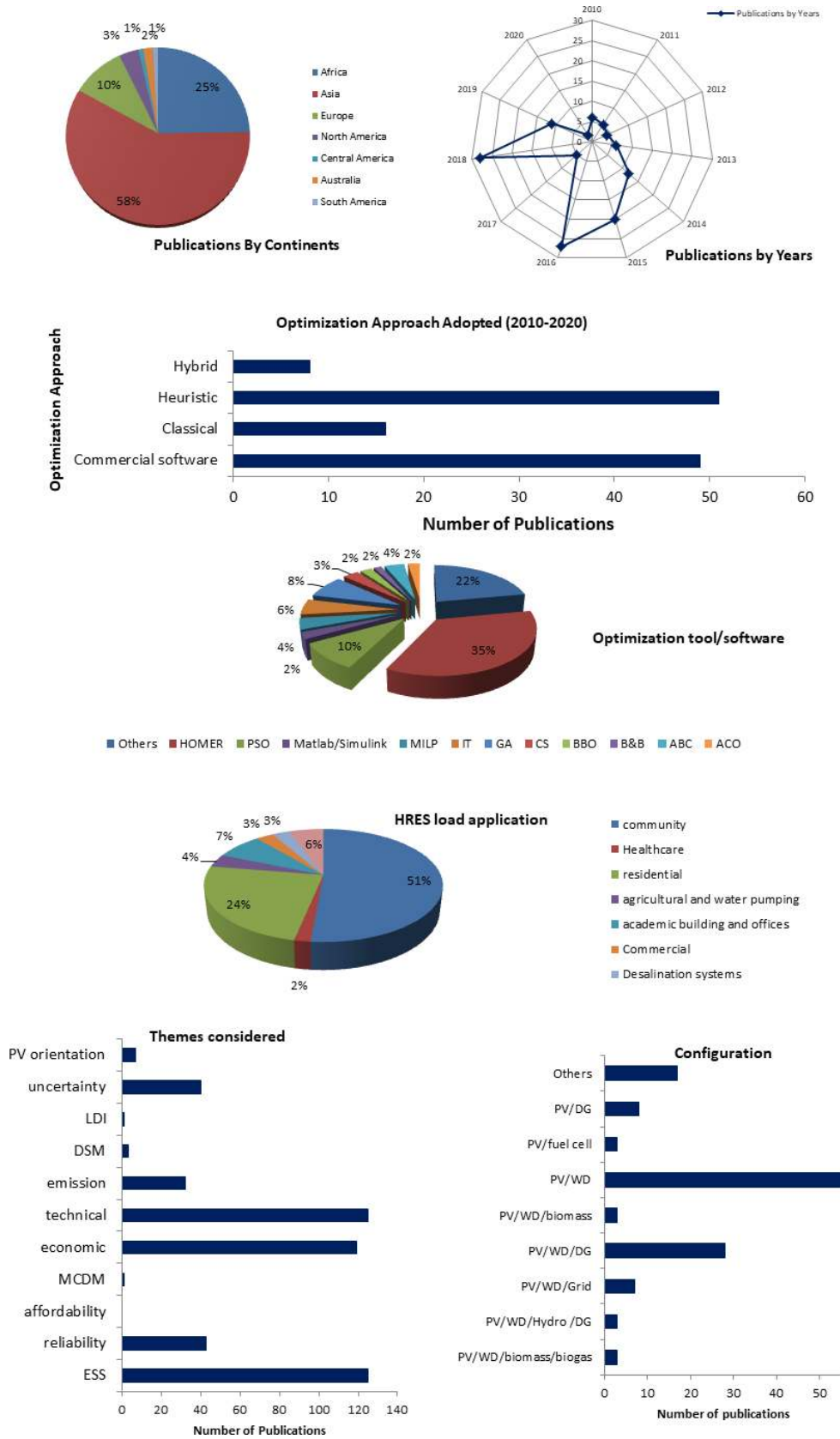

FIGURE 18. Summary of studies compared.

and cost effective, however, the PV-wind-fossil fuel-powered generator-battery is more reliable due to the addition of fossil fuel-powered generator.

Depending on the energy source, literature has been able to identify 3 coupling methods of HRES- these include AC-connected, DC-connected or hybrid-connected (AC-DC). In the AC-connected HRES nomenclature, all energy sources are connected to an AC bus through the appropriate power electronic converters. The aggregate output is then used to power the connected load(s). For this configuration, AC loads are powered directly while DC loads are powered through AC-DC converter (rectifier). As for the DC-coupled HRES configuration, energy sources are connected to a DC bus through appropriate power electronics converters. DC loads are directly connected to the DC bus, while AC loads are connected through DC-AC power electronics converters (inverter). These conversion processes, however, lead to various losses and decrease in efficiency. Also, failure of the converters may affect the reliability of energy supply. The hybrid coupled configuration combines both AC and DC bus. All AC energy sources are used to directly power AC loads through the AC bus, while all DC energy sources are used to directly power DC loads through the DC bus. This hybrid configuration eliminates /minimizes the number of electronic converters, minimizes energy losses, increases efficiency and reduces the overall investment and maintenance costs.

A very important component of a HRES when intermittent energy sources (e.g. Solar and wind) are included is energy storage system. It levels out the effects of intermittency of renewable energy supply by serving as backup at times of energy shortage. Energy storage systems are also used as peak shavers and smoothers with respect to energy demand fluctuations. Based on the duration and period of storage, ESS technologies are classified as long, medium or short storage. Another classification identified by the literature is based on the form of storage which is mechanical, electrical and chemical. Generally, installation of energy storage devices is expensive [284]. Based on the reviewed studies, the most common energy storage technology considered is the battery storage which needs replacement on a periodic basis due to its short lifespan. Over a project lifetime, the battery bank may be replaced 5 times; this usually makes the TNPC of the battery bank the highest as compared to other components.

Most of the studies on HRES propose the minimization of TNPC, levelized cost of energy and annualized system cost to obtain the most economically viable system. In some cases, the minimization of capacity shortage is included to increase system reliability. This means that the sizing of a HRES is an optimization problem with single or more objectives and a set of related constraints. Some of the constraints that have been regularly used in the literature are related to power balance, number of components (generators, storage devices, power electronic devices), maximum budget, storage device status, and reliability. Some of the reliability indices that

have found application on the sizing and modeling of HRES include capacity shortage, LPSP, LLP, EENS. Some of the decision variables that have been considered in the literature include the number and capacity of components (PV array, wind turbines, conventional generators, batteries), tilt angle to achieve maximum tracking, renewable fraction, quantity of emission.

In order to achieve optimality, studies on HRES have adopted various classical and meta-heuristic optimization approaches. Meta-heuristic optimization approaches such as PSO, GA, ABC, SA and BBO are the most commonly used in the modeling and sizing of HRES. As a way of improving solution obtained in the mathematical optimization of HRES, researchers have also proposed the hybridization of various techniques. While hybridization of optimization techniques offer improved overall performance of solutions, it has been seen to exhibit some limitations. For instance, partial optimism was attributed to the MCS-PSO hybrid optimization method used by Bashir and Sadeh [220]. Some other limitations of hybrid optimization techniques in the design and sizing of HRES include: suboptimal solutions attributed to an iterative-GA hybrid optimization technique [221], complexities in design as seen in the hybridization of ANN-GA-MCS [285], complexity in coding as evident in the response-surface-based method combined with a Monte Carlo method [286], arbitrary adjustment of inertial weights of the evolutionary algorithm implemented [125] and the technical-economic compromise [222], [287]. Apart from the above optimization methods, some popular commercially available software has been developed and extensively used for the modelling and optimization of HRES. Some of them include HOMER, HOGA, HYBRID, RETScreen. Out of the commercially available software for the modelling of HRES, HOMER is the most widely used due to its robustness.

Since a HRES consists of two or more energy sources and energy storage supplying the load, it is important to ensure that all connected components properly communicate with each other for optimal operations. This is particularly essential because the outputs of different energy sources are different-some are AC while others are DC. All these output must be aggregated to supply the load. As such an appropriate control mechanism is inevitable when setting up a HRES. A control mechanism also helps in energy dispatch, monitoring the status of the energy storage (e.g. State of charge of battery), optimal operation of fossil power generation to ensure minimum energy cost, and also ensure voltage stability at the buses (voltage regulation). The control mechanisms adopted in HRES development are categorized as distributed, centralized, and hybrid control arrangement. In the centralized control configuration, a centralized controller coordinates various slave controllers (also known as local controllers) to which the energy sources and energy storage are connected. Distributed control configuration ensures that all the slave controllers of the various energy sources communicate with each to ensure effective operation of the whole system. The hybrid control configuration combines the architecture

of both the centralized and distributed controllers- distributed control is used to control each group, while centralized control is used within each group.

XII. CONCLUSION AND FUTURE DIRECTIONS

To accomplish the sustainable developmental goal in relation to affordable and clean energy for all, there is a need to strengthen and direct research efforts into the use and adoption of RE. This is because many locations across the world (rural and urban) have one or more abundant renewable energy resource that can be harnessed for electricity generation. However, some of these renewable energy sources are intermittent in nature and their power outputs may be unreliable. For this reason, researchers and decision-makers have proposed the use of hybrid renewable energy system (HRES) as a realistic alternative for rural electrification and decarbonization of the electricity sector. This has been extensively studied over the decades with various researches proposing various combinations of feasible HRES. This study has presented a state-of-the-art review on various themes of HRES. Some of the themes covered in this review include: optimization approach, control mechanisms, energy storage system, reliability, techno-economic perspectives, emission evaluation, multiple criteria assessment, demand side management (DSM) activities, load demand increase (LDI), uncertainty assessment, PV tracking orientation, consumer type, and system configuration. A periodic review of these themes will help in identifying research gaps that must be filled in order to improve future HRES. Although tremendous accomplishments have been achieved over the years on the modeling and optimization of HRES, a review of the literature shows that additional enhancements could still be achieved. The list below highlights some of the issues that could be investigated in future.

- 1) Available studies on HRES seem to concentrate only on its techno-economic and environmental viability. In so doing, these studies do not seem to underline the likely challenges that follow the acquisition of HRES by low-income households. The ensuing reality is, of course, a limitation in the use of HRES in homes with low incomes. It is therefore imperative to analyze how a household with low income can afford this kind of energy system. The purpose of this lies in presenting a techno-economic, environmental and affordability analysis of how HRES can be acquired by low income households.
- 2) The selection of an optimal HRES involves considering conflicting criteria. Based on literature review, only the economic and technical aspects are the most prominent criteria that have been used for the selection and ranking of optimal HRES [288]–[290]. However, HRES selected based solely on these two criteria may fail in developing countries because of maintenance and repair difficulties, obsolescence of system components, and the fact that the technology has not been adapted to the climate [291], [292]. The consideration

of other criteria related to social, environmental, and policy in the selection and ranking of HRES especially in household applications are also very important and should be investigated. Since the boundaries of the diverse sustainability factor usually intercept, the use of multi-criteria decision-making frameworks, could be used to select and rank HRES alternatives.

- 3) The design, modeling and optimization of HRES for residential application is not entirely new as it has been extensively studied (see Table 3). However, most of these studies are case-specific with no consideration for uncertainties. Meanwhile, changes in inflation rates will affect the interest rates, fuel price, and the component prices over the project life time. Also, the energy demand of a residential consumer is not expected to remain constant for the duration of the HRES lifetime because there may be progressive energy-level transition. Consequently, it will be thought-provoking to investigate the effects of progressive energy level transition, changes in interest rates, fluctuating fuel price. on the technical and economic details of the optimal HRES.
- 4) The techno-economic and environmental viability of adopting both grid-dependent and grid-independent HRES with PV as one of the components has been previously investigated (see table 3). However, comparative studies that explore both the effects of various tracking architecture and temperature on the output of PV panel and the techno-economic details of the entire HRES are very few. More efforts in investigating these gaps especially for residential application will be interesting.
- 5) Based on the insights from the reviewed studies, battery energy storage is the most commonly used ESS for community and especially residential HRES. Battery energy storage has a short lifespan compared to ESS technologies such as pumped-hydro and so the need to be periodically replaced. This usually makes the TNPC of the battery bank very high over the entire project lifetime. The development of cost effective battery storage systems with high performance is needed. It will entail intensive and robust research and development.
- 6) Daily energy demand pattern is an indispensable input for grid-independent HRES operations and planning in rural areas. This will help in the control of energy flow among the various system components. So far, very little research attention has been devoted to specific methodologies of obtaining daily load profiles estimates for rural consumers. In order to bridge this research gap, the development, implementation and application of innovative models that can be used in obtaining the daily energy consumption of grid-independent rural consumers are needed.
- 7) Majority of energy users in developing countries make use of electrical appliances that are not energy efficient.

This usually has an effect on the magnitude of the load and consequently the size of a HRES needed to serve such loads. The effects of energy efficient activities (DSM,DR) on the technical, cost and emission features of HRES need to be considered in future studies.

Nomenclature

P_{bmg}	power output of a gasifier
CV_{bmg}	calorific value off biomass
η_{bmg}	overall conversion efficiency of the entire gasifier system
P_{pv}	power output of a PV panel
Y_{pv}	rated capacity of PV array
f_{pv}	PV derating factor
$\overline{G_T}$	solar irradiation incident on the PV array
$\overline{G_{T,STC}}$	solar irradiation incident at standard condition
α_{pv}	temperature coefficient of power
T_c	PV cell temperature
$T_{c,STC}$	PV cell temperature under standard test conditions
P_{out}	output of wind energy system
V	wind Speed
V_{ci}	cut-in speed
V_{co}	cut-out speed
P_R	power rating of the turbine
V_R	wind turbine rated speed
k	weibull shape factor
c	weibull scale parameter
V_{ref}	wind speed measured at the reference height
H_{ref}	reference height
H	new height of wind turbine
β	power law exponent
e	type of equipment/ appliance
f	class of consumer
N_e	number of users within class
P_{ef}	nominal electric power rating of an equipment
t_{ef}	overall duration of use of each equipment
E_d	energy demand
N_{ef}	number of equipment belonging to specific class

ACKNOWLEDGMENT

The opinions expressed and conclusions arrived at, are those of the authors and are not necessarily to be attributed to the NRF.

REFERENCES

- [1] O. M. Babatunde, J. L. Munda, and Y. Hamam, "Selection of a hybrid renewable energy systems for a low-income household," *Sustainability*, vol. 11, no. 16, p. 4282, Aug. 2019.
- [2] Y. S. Mohammed, M. W. Mustafa, and N. Bashir, "Hybrid renewable energy systems for off-grid electric power: Review of substantial issues," *Renew. Sustain. Energy Rev.*, vol. 35, pp. 527–539, Jul. 2014.
- [3] N. Patel, *AFRICA IN FOCUS-Figure of the week: Electricity access in Africa*. Accessed: Oct. 9, 2019. [Online]. Available: <https://www.brookings.edu/blog/africa-in-focus/2019/03/29/figure-of-the-week-electricity-access-in-africa/>
- [4] United Nations. (2015). *Sustainable Development Goals*. Accessed: Dec. 5, 2019. [Online]. Available: <https://www.undp.org/content/undp/en/home/sustainable-development-goals.html>
- [5] O. M. Babatunde, J. L. Munda, and Y. Hamam, "A comprehensive state-of-the-art survey on power generation expansion planning with intermittent renewable energy source and energy storage," *Int. J. Energy Res.*, vol. 43, no. 12, pp. 6078–6107, Mar. 2019.
- [6] (IRENA). *Renewable Energy Now Accounts for a Third of Global Power Capacity*. Accessed: May 18, 2019. [Online]. Available: <https://www.irena.org/newsroom/pressreleases/2019/Apr/Renewable-Energy-Now-Accounts-for-a-Third-of-Global-Power-Capacity>
- [7] O. A. Ajeigbe, J. L. Munda, and Y. Hamam, "Optimal allocation of renewable energy hybrid distributed generations for small-signal stability enhancement," *Energies*, vol. 12, no. 24, p. 4777, Dec. 2019.
- [8] O. A. Ajeigbe, J. L. Munda, and Y. Hamam, "Towards maximising the integration of renewable energy hybrid distributed generations for small signal stability enhancement: A review," *Int. J. Energy Res.*, vol. 44, no. 4, pp. 2379–2425, Jan. 2020.
- [9] A. Jha, *Solar Power From Saharan Sun Could Provide Europe's Electricity*, Says EU. London, U.K.: The Guardian, 2008.
- [10] D. O. Akinyele and R. K. Rayudu, "Review of energy storage technologies for sustainable power networks," *Sustain. Energy Technol. Assessments*, vol. 8, pp. 74–91, Dec. 2014.
- [11] T. Kousksou, P. Bruel, A. Jamil, T. El Rhafiki, and Y. Zeraoui, "Energy storage: Applications and challenges," *Sol. Energy Mater. Sol. Cells*, vol. 120, pp. 59–80, Jan. 2014.
- [12] S. Koohi-Kamali, V. V. Tyagi, N. A. Rahim, N. L. Panwar, and H. Mokhlis, "Emergence of energy storage technologies as the solution for reliable operation of smart power systems: A review," *Renew. Sustain. Energy Rev.*, vol. 25, pp. 135–165, Sep. 2013.
- [13] D. O. Akinyele and R. K. Rayudu, "Comprehensive techno-economic and environmental impact study of a localised photovoltaic power system (PPS) for off-grid communities," *Energy Convers. Manage.*, vol. 124, pp. 266–279, Sep. 2016.
- [14] A. Adeyeye, J. Tsado, and L. Olatomiwa, "Techno-economic analysis of PV/diesel/battery hybrid renewable system for remote primary health-care centre," in *Proc. Int. Conf. Mech. Eng., Energy Technol. Manage. (IMEETMCON)*, 2018, vol. 30, no. 1, pp. 1–9.
- [15] C. G. Monyei, A. O. Adewumi, D. Akinyele, O. M. Babatunde, M. O. Obolo, and J. C. Onunwor, "A biased load manager home energy management system for low-cost residential building low-income occupants," *Energy*, vol. 150, pp. 822–838, May 2018.
- [16] O. Adeoti, B. A. Oyewole, and T. D. Adegboyega, "Solar photovoltaic-based home electrification system for rural development in Nigeria: Domestic load assessment," *Renew. Energy*, vol. 24, no. 1, pp. 155–161, Sep. 2001.
- [17] M. S. Adaramola, "Viability of grid-connected solar PV energy system in Jos, Nigeria," *Int. J. Electr. Power Energy Syst.*, vol. 61, pp. 64–69, Oct. 2014.
- [18] Planete-Energies. (2016). *Electricity Generation and Related CO₂ Emissions*. [Online]. Available: <https://www.planete-energies.com/en/medias/close/electricity-generation-and-related-co2-emissions>
- [19] U. Nations. (2013). *Sustainable Development Goals*. [Online]. Available: <https://sustainabledevelopment.un.org/?menu=1300>
- [20] E. Reguly and S. Mccarthy, *Paris Climate Accord Marks Shift Toward Low-Carbon Economy*. Toronto, ON, Canada: Globe Mail, 2015.
- [21] B. Bhandari, K.-T. Lee, G.-Y. Lee, Y.-M. Cho, and S.-H. Ahn, "Optimization of hybrid renewable energy power systems: A review," *Int. J. Precis. Eng. Manuf.-Green Technol.*, vol. 2, no. 1, pp. 99–112, 2015.
- [22] F. M. Hossain, M. Hasanuzzaman, N. Rahim, and H. Ping, "Impact of renewable energy on rural electrification in Malaysia: A review," *Clean Technol. Environ. Policy*, vol. 17, no. 4, pp. 859–871, 2015.
- [23] Y. Liu, S. Yu, Y. Zhu, D. Wang, and J. Liu, "Modeling, planning, application and management of energy systems for isolated areas: A review," *Renew. Sustain. Energy Rev.*, vol. 82, pp. 460–470, Feb. 2018.
- [24] S. Sinha and S. S. Chandel, "Review of software tools for hybrid renewable energy systems," *Renew. Sustain. Energy Rev.*, vol. 32, pp. 192–205, Apr. 2014.
- [25] S. Bahramara, M. P. Moghaddam, and M. Haghifam, "Optimal planning of hybrid renewable energy systems using homer: A review," *Renew. Sustain. Energy Rev.*, vol. 62, pp. 609–620, 2016.
- [26] L. Olatomiwa, S. Mekhilef, M. S. Ismail, and M. Moghavvemi, "Energy management strategies in hybrid renewable energy systems: A review," *Renew. Sustain. Energy Rev.*, vol. 62, pp. 821–835, Sep. 2016.

- [27] S. Upadhyay and M. P. Sharma, "A review on configurations, control and sizing methodologies of hybrid energy systems," *Renew. Sustain. Energy Rev.*, vol. 38, pp. 47–63, Oct. 2014.
- [28] M. D. A. Al-falahi, S. D. G. Jayasinghe, and H. Enshaei, "A review on recent size optimization methodologies for standalone solar and wind hybrid renewable energy system," *Energy Convers. Manage.*, vol. 143, pp. 252–274, Jul. 2017.
- [29] R. Siddaiah and R. P. Saini, "A review on planning, configurations, modeling and optimization techniques of hybrid renewable energy systems for off grid applications," *Renew. Sustain. Energy Rev.*, vol. 58, pp. 376–396, May 2016.
- [30] A. Chauhan and R. P. Saini, "A review on integrated renewable energy system based power generation for stand-alone applications: Configurations, storage options, sizing methodologies and control," *Renew. Sustain. Energy Rev.*, vol. 38, pp. 99–120, Oct. 2014.
- [31] A. Darmani, N. Arvidsson, A. Hidalgo, and J. Albers, "What drives the development of renewable energy technologies? Toward a typology for the systemic drivers," *Renew. Sustain. Energy Rev.*, vol. 38, pp. 834–847, Oct. 2014.
- [32] K. Anoune, M. Bouya, A. Astito, and A. B. Abdellah, "Sizing methods and optimization techniques for PV-wind based hybrid renewable energy system: A review," *Renew. Sustain. Energy Rev.*, vol. 93, pp. 652–673, Oct. 2018.
- [33] S. M. Dawoud, X. Lin, and M. I. Okba, "Hybrid renewable microgrid optimization techniques: A review," *Renew. Sustain. Energy Rev.*, vol. 82, pp. 2039–2052, Feb. 2018.
- [34] N. Phuangpornpitak and S. Kumar, "PV hybrid systems for rural electrification in thailand," *Renew. Sustain. Energy Rev.*, vol. 11, no. 7, pp. 1530–1543, Sep. 2007.
- [35] M. A. Elhadidy, "Performance evaluation of hybrid (wind/solar/diesel) power systems," *Renew. Energy*, vol. 26, no. 3, pp. 401–413, Jul. 2002.
- [36] S. Rehman and L. M. Al-Hadhrani, "Study of a solar PV–diesel–battery hybrid power system for a remotely located population near Rafha, Saudi Arabia," *Energy*, vol. 35, no. 12, pp. 4986–4995, Dec. 2010.
- [37] D. Xu, L. Kang, L. Chang, and B. Cao, "Optimal sizing of standalone hybrid wind/PV power systems using genetic algorithms," in *Proc. Can. Conf. Electr. Comput. Eng.*, May 2005, pp. 1722–1725.
- [38] R. Luna-Rubio, M. Trejo-Perea, D. Vargas-Vázquez, and G. J. Ríos-Moreno, "Optimal sizing of renewable hybrids energy systems: A review of methodologies," *Sol. Energy*, vol. 86, no. 4, pp. 1077–1088, Apr. 2012.
- [39] O. Erdinc and M. Uzunoglu, "Recent trends in PEM fuel cell-powered hybrid systems: Investigation of application areas, design architectures and energy management approaches," *Renew. Sustain. Energy Rev.*, vol. 14, no. 9, pp. 2874–2884, Dec. 2010.
- [40] B. Bala and S. A. Siddique, "Optimal design of a PV-diesel hybrid system for electrification of an isolated island—Sandwip in Bangladesh using genetic algorithm," *Energy Sustain. Develop.*, vol. 13, no. 3, pp. 137–142, 2009.
- [41] K. Sopian, A. Zaharim, Y. Ali, Z. M. Nopiah, J. A. Razak, and N. S. Muhammad, "Optimal operational strategy for hybrid renewable energy system using genetic algorithms," *WSEAS Trans. Math.*, vol. 7, no. 4, pp. 130–140, 2008.
- [42] C. Protogeropoulos, B. J. Brinkworth, and R. H. Marshall, "Sizing and techno-economical optimization for hybrid solar photovoltaic/wind power systems with battery storage," *Int. J. Energy Res.*, vol. 21, no. 6, pp. 465–479, May 1997.
- [43] I. E. Agency, *Distributed Generation in Liberalised Electricity Markets*. Paris, France: OECD, 2002.
- [44] P. Nema, S. Nema, and P. Roy, "An overview of global climate changing in current scenario and mitigation action," *Renew. Sustain. Energy Rev.*, vol. 16, no. 4, pp. 2329–2336, May 2012.
- [45] G. Pepermans, J. Driesen, D. Haeseldonckx, R. Belmans, and W. D'Haeseleer, "Distributed generation: Definition, benefits and issues," *Energy Policy*, vol. 33, no. 6, pp. 787–798, Apr. 2005.
- [46] (IRENA). (2019). *Data, Research and Resources on Renewable Energy Costs*. [Online]. Available: <https://www.irena.org/costs>
- [47] D. Akinyele, J. Belikov, and Y. Levron, "Battery storage technologies for electrical applications: Impact in stand-alone photovoltaic systems," *Energies*, vol. 10, no. 11, p. 1760, Nov. 2017.
- [48] M. C. Argyrou, P. Christodoulides, and S. A. Kalogirou, "Energy storage for electricity generation and related processes: Technologies appraisal and grid scale applications," *Renew. Sustain. Energy Rev.*, vol. 94, pp. 804–821, Oct. 2018.
- [49] B. P. Koirala, E. van Oost, and H. van der Windt, "Community energy storage: A responsible innovation towards a sustainable energy system?" *Appl. Energy*, vol. 231, pp. 570–585, Dec. 2018.
- [50] International Energy Association. (2012). *How Will Global Energy Markets Evolve to 2035*. *World Energy Outlook*. Accessed: Oct. 12, 2019. [Online]. Available: https://www.mitchellwilliamslaw.com/files/scan_attachment10084.pdf
- [51] V. Oree, S. Z. Sayed Hassen, and P. J. Fleming, "Generation expansion planning optimisation with renewable energy integration: A review," *Renew. Sustain. Energy Rev.*, vol. 69, pp. 790–803, Mar. 2017.
- [52] H. Sadeghi, M. Rashidinejad, and A. Abdollahi, "A comprehensive sequential review study through the generation expansion planning," *Renew. Sustain. Energy Rev.*, vol. 67, pp. 1369–1394, Jan. 2017.
- [53] N. E. Koltsaklis and A. S. Dagoumas, "State-of-the-art generation expansion planning: A review," *Appl. Energy*, vol. 230, pp. 563–589, Nov. 2018.
- [54] A. Markandya and P. Wilkinson, "Electricity generation and health," *Lancet*, vol. 370, no. 9591, pp. 979–990, 2007.
- [55] A. Freiberg, J. Scharfe, V. C. Murta, and A. Seidler, "The use of biomass for electricity generation: A scoping review of health effects on humans in residential and occupational settings," *Int. J. Environ. Res. Public Health*, vol. 15, no. 2, p. 354, Feb. 2018.
- [56] J. L. Sawin, E. Martinot, V. Sonntag-O'Brien, A. McCrone, J. Roussel, D. Barnes, C. Flavin, L. Mastny, D. Kraft, and S. Wang, "Renewables 2010-global status report," REN21 Secretariat, Paris, France, Global Status Rep. REN21, 2010.
- [57] G. Qiu, Y. Shao, J. Li, H. Liu, and S. B. Riffat, "Experimental investigation of a biomass-fired ORC-based micro-CHP for domestic applications," *Fuel*, vol. 96, pp. 374–382, Jun. 2012.
- [58] H. Liu, Y. Shao, and J. Li, "A biomass-fired micro-scale CHP system with organic rankine cycle (ORC)—Thermodynamic modelling studies," *Biomass Bioenergy*, vol. 35, no. 9, pp. 3985–3994, Oct. 2011.
- [59] R. Padinger, S. Aigenbauer, and C. Schmidl, "Best practise report on decentralized biomass fired CHP plants and status of biomass fired small- and micro scale CHP technologies," Int. Energy Agency, IEA Bioenergy, Paris, France, Tech. Rep., 2019.
- [60] K. Madsen and N. Bentsen, "Carbon debt payback time for a biomass fired chp plant—A case study from northern Europe," *Energies*, vol. 11, no. 4, p. 807, 2018.
- [61] A. Sorrentino, A. M. Pantaleo, C. N. Markides, G. Braccio, E. Fanelli, S. Acha, and S. M. Camporeale, "Energy performance and profitability of biomass boilers in the commercial sector: A case study in the UK," *Energy Procedia*, vol. 148, pp. 639–646, Aug. 2018.
- [62] C. Tagliaferri, S. Evangelisti, R. Clift, and P. Lettieri, "Life cycle assessment of a biomass CHP plant in UK: The heathrow energy centre case," *Chem. Eng. Res. Design*, vol. 133, pp. 210–221, May 2018.
- [63] A. Evans, V. Strezov, and T. J. Evans, "Sustainability considerations for electricity generation from biomass," *Renew. Sustain. energy Rev.*, vol. 14, no. 5, pp. 1419–1427, 2010.
- [64] S. Mandelli, J. Barbieri, R. Mereu, and E. Colombo, "Off-grid systems for rural electrification in developing countries: Definitions, classification and a comprehensive literature review," *Renew. Sustain. Energy Rev.*, vol. 58, pp. 1621–1646, May 2016.
- [65] E. Jin and J. W. Sutherland, "An integrated sustainability model for a bioenergy system: Forest residues for electricity generation," *Biomass Bioenergy*, vol. 119, pp. 10–21, Dec. 2018.
- [66] IRENA, "Renewable capacity statistics 2017," Int. Renew. Energy Agency, Masdar City, Abu Dhabi, Tech. Rep., 2017, pp. 28–29.
- [67] Allpowerlabs. *How Gasification Works*. Accessed: Oct. 14, 2019. [Online]. Available: <http://www.allpowerlabs.com/gasification-explained>
- [68] A. Gupta, R. Saini, and M. Sharma, "Modelling of hybrid energy system—Part I: Problem formulation and model development," *Renew. Energy*, vol. 36, no. 2, pp. 459–465, 2011.
- [69] R. Charron and A. Athienitis, "Design and optimization of net zero energy solar homes," *ASHRAE Trans.*, vol. 112, no. 2, p. 1–12, 2006.
- [70] D. Akinyele, O. Babatunde, C. Monyei, L. Olatomiwa, A. Okediji, D. Ighravwe, O. Abiodun, M. Onasanya, and K. Temikotan, "Possibility of solar thermal power generation technologies in Nigeria: Challenges and policy directions," *Renew. Energy Focus*, vol. 29, pp. 24–41, Jun. 2019.
- [71] Centre for Renewable & Sustainable Energy Studies. *New Solar Resource Maps for South Africa*. Accessed: Oct. 14, 2019. [Online]. Available: <https://www.energy.org.za/news/158-new-solar-resource-maps-for-south-africa>

- [72] S.-E. Thor and P. Weis-Taylor, "Long-term research and development needs for wind energy for the time frame 2000-2020," *Wind Energy, Int. J. Prog. Appl. Wind Power Convers. Technol.*, vol. 5, no. 1, pp. 73–75, 2002.
- [73] L. C. Henriksen, "Wind energy literature survey no. 27," *Wind Energy*, vol. 16, no. 1, pp. 159–161, 2013.
- [74] R. Baños, F. Manzano-Agugliaro, F. G. Montoya, C. Gil, A. Alcayde, and J. Gómez, "Optimization methods applied to renewable and sustainable energy: A review," *Renew. Sustain. Energy Rev.*, vol. 15, no. 4, pp. 1753–1766, May 2011.
- [75] E. Asadi and S. Sadjadi, "Optimization methods applied to renewable and sustainable energy: A review," *Uncertain Supply Chain Manage.*, vol. 5, no. 1, pp. 1–26, 2017.
- [76] M. Li and X. Li, "Investigation of wind characteristics and assessment of wind energy potential for Waterloo region, Canada," *Energy Convers. Manage.*, vol. 46, nos. 18–19, pp. 3014–3033, Nov. 2005.
- [77] P. Gipe, "Wind energy comes of age California and Denmark," *Energy Policy*, vol. 19, no. 8, pp. 756–767, Oct. 1991.
- [78] M. J. Dvorak, C. L. Archer, and M. Z. Jacobson, "California offshore wind energy potential," *Renew. Energy*, vol. 35, no. 6, pp. 1244–1254, Jun. 2010.
- [79] X. Changliang and S. Zhanfeng, "Wind energy in China: Current scenario and future perspectives," *Renew. Sustain. Energy Rev.*, vol. 13, no. 8, pp. 1966–1974, Oct. 2009.
- [80] S. Gupta, Y. Kumar, and G. Agnihotri, "REAST: Renewable energy analysis and sizing tool," *J. Elect. Syst.*, vol. 7, no. 2, pp. 206–224, Jun. 2011.
- [81] J. P. Barton and D. G. Infield, "Energy storage and its use with intermittent renewable energy," *IEEE Trans. Energy Convers.*, vol. 19, no. 2, pp. 441–448, Jun. 2004.
- [82] J. Makansi and J. Abboud, "Energy storage: The missing link in the electricity value chain," Energy Storage Council, Albanvale, VIC, Australia, White Paper, 2002.
- [83] M. Aneke and M. Wang, "Energy storage technologies and real life applications—A state of the art review," *Appl. Energy*, vol. 179, pp. 350–377, Oct. 2016.
- [84] J. C. Beardsall, C. A. Gould, and M. Al-Tai, "Energy storage systems: A review of the technology and its application in power systems," in *Proc. 50th Int. Universities Power Eng. Conf. (UPEC)*, Sep. 2015, pp. 1–6.
- [85] C. Abbey, J. Robinson, and G. Joos, "Integrating renewable energy sources and storage into isolated diesel generator supplied electric power systems," in *Proc. 13th Int. Power Electron. Motion Control Conf.*, Sep. 2008, pp. 2178–2183.
- [86] H. Chen, T. N. Cong, W. Yang, C. Tan, Y. Li, and Y. Ding, "Progress in electrical energy storage system: A critical review," *Prog. Natural Sci.*, vol. 19, no. 3, pp. 291–312, Mar. 2009.
- [87] M. Nehrir, C. Wang, K. Strunz, H. Aki, R. Ramakumar, J. Bing, Z. Miao, and Z. Salame, "A review of hybrid renewable/alternative energy systems for electric power generation: Configurations, control, and applications," *IEEE Trans. Sustain. Energy*, vol. 2, no. 4, pp. 392–403, Oct. 2011.
- [88] M. H. Amrollahi and S. M. T. Bathaee, "Techno-economic optimization of hybrid photovoltaic/wind generation together with energy storage system in a stand-alone micro-grid subjected to demand response," *Appl. Energy*, vol. 202, pp. 66–77, Sep. 2017.
- [89] M. Qolipour, A. Mostafaeipour, and O. M. Tousei, "Techno-economic feasibility of a photovoltaic-wind power plant construction for electric and hydrogen production: A case study," *Renew. Sustain. Energy Rev.*, vol. 78, pp. 113–123, Oct. 2017.
- [90] O. Nadjemi, T. Nacer, A. Hamidat, and H. Salhi, "Optimal hybrid PV/wind energy system sizing: Application of cuckoo search algorithm for Algerian dairy farms," *Renew. Sustain. Energy Rev.*, vol. 70, pp. 1352–1365, Apr. 2017.
- [91] N. Ghorbani, A. Kasaean, A. Toopshekan, L. Bahrami, and A. Maghami, "Optimizing a hybrid wind-PV-battery system using GA-PSO and MOPSO for reducing cost and increasing reliability," *Energy*, vol. 154, pp. 581–591, Jul. 2018.
- [92] A. Khiareddine, C. Ben Salah, D. Rekioua, and M. F. Mimouni, "Sizing methodology for hybrid photovoltaic/wind/hydrogen/battery integrated to energy management strategy for pumping system," *Energy*, vol. 153, pp. 743–762, Jun. 2018.
- [93] A. Lorestani and M. M. Ardehali, "Optimization of autonomous combined heat and power system including PVT, WT, storages, and electric heat utilizing novel evolutionary particle swarm optimization algorithm," *Renew. Energy*, vol. 119, pp. 490–503, Apr. 2018.
- [94] G. Singh, P. Baredar, A. Singh, and D. Kurup, "Optimal sizing and location of PV, wind and battery storage for electrification to an island: A case study of Kavaratti, Lakshadweep," *J. Energy Storage*, vol. 12, pp. 78–86, Aug. 2017.
- [95] M. Haratian, P. Tabibi, M. Sadeghi, B. Vaseghi, and A. Poustdouz, "A renewable energy solution for stand-alone power generation: A case study of KhshU site-Iran," *Renew. Energy*, vol. 125, pp. 926–935, Sep. 2018.
- [96] A. Giallanza, M. Porretto, G. L. Puma, and G. Marannano, "A sizing approach for stand-alone hybrid photovoltaic-wind-battery systems: A sicilian case study," *J. Cleaner Prod.*, vol. 199, pp. 817–830, Oct. 2018.
- [97] S. Sanajaoba and E. Fernandez, "Maiden application of cuckoo search algorithm for optimal sizing of a remote hybrid renewable energy system," *Renew. Energy*, vol. 96, pp. 1–10, Oct. 2016.
- [98] R. Hosseinalizadeh, H. Shakouri, M. S. Amalnick, and P. Taghipour, "Economic sizing of a hybrid (PV-WT-FC) renewable energy system (HRES) for stand-alone usages by an optimization-simulation model: Case study of Iran," *Renew. Sustain. Energy Rev.*, vol. 54, pp. 139–150, 2016.
- [99] H.-S. Ko and J. Jatskevich, "Power quality control of wind-hybrid power generation system using fuzzy-LQR controller," *IEEE Trans. Energy Convers.*, vol. 22, no. 2, pp. 516–527, Jun. 2007.
- [100] Z. Jiang and R. A. Dougal, "Hierarchical microgrid paradigm for integration of distributed energy resources," in *Proc. 21st IEEE Power Energy Soc. Gen. Meeting Convers. Del. Electr. Energy Century*, Jul. 2008, pp. 1–8.
- [101] A. Chakraborty, "Advancements in power electronics and drives in interface with growing renewable energy resources," *Renew. Sustain. Energy Rev.*, vol. 15, no. 4, pp. 1816–1827, May 2011.
- [102] J. M. Carrasco, L. G. Franquelo, J. T. Bialasiewicz, E. Galvan, R. C. PortilloGuisado, M. A. M. Prats, J. I. Leon, and N. Moreno-Alfonso, "Power-electronic systems for the grid integration of renewable energy sources: A survey," *IEEE Trans. Ind. Electron.*, vol. 53, no. 4, pp. 1002–1016, Jun. 2006.
- [103] S. Alepuz, S. Busquets-Monge, J. Bordonau, J. Gago, D. Gonzalez, and J. Balcells, "Interfacing renewable energy sources to the utility grid using a three-level inverter," *IEEE Trans. Ind. Electron.*, vol. 53, no. 5, pp. 1504–1511, Oct. 2006.
- [104] A. T. Olusegun, A. Z. Adebukola, I. H. Denwigwe, P. O. Oluseyi, and B. M. Olubayo, "Comparative analysis of two direct MPPT methods used for tracking maximum power points in a photovoltaic system," *World Sci. News*, vol. 131, pp. 123–146, 2019.
- [105] S. Agoro, A. Balogun, O. Ojo, and F. Okafor, "Control of a three-phase multi-string five-level inverter for grid integration of PV SystEms with unbalanced DC-link voltages," in *Proc. 9th IEEE Int. Symp. Power Electron. Distrib. Gener. Syst. (PEDG)*, Jun. 2018, pp. 1–6.
- [106] S. Agoro, A. Balogun, O. Ojo, and F. Okafor, "Direct model-based predictive control of a three-phase grid connected VSI for photovoltaic power evacuation," in *Proc. 9th IEEE Int. Symp. Power Electron. Distrib. Gener. Syst. (PEDG)*, Jun. 2018, pp. 1–6.
- [107] M. P. Blimpo and M. Cosgrove-Davies, *Electricity Access in Sub-Saharan Africa: Uptake, Reliability, and Complementary Factors for Economic Impact*. Washington, DC, USA: World Bank Publications, 2019.
- [108] O. D. T. Odou, R. Bhandari, and R. Adamou, "Hybrid off-grid renewable power system for sustainable rural electrification in benin," *Renew. Energy*, vol. 145, pp. 1266–1279, Jan. 2020.
- [109] K. C. Meje, L. Bokopane, and K. Kusakana, "Practical implementation of hybrid energy systems for small loads in rural south Africa," in *Proc. Open Innov. Conf. (OI)*, Oct. 2018, pp. 293–298.
- [110] E. Ayodele, S. Misra, R. Damasevicius, and R. Maskeliunas, "Hybrid microgrid for microfinance institutions in rural areas—A field demonstration in west Africa," *Sustain. Energy Technol. Assessments*, vol. 35, pp. 89–97, Oct. 2019.
- [111] D. Conway, B. Robinson, P. Mudimu, T. Chitekwe, K. Koranteng, and M. Swilling, "Exploring hybrid models for universal access to basic solar energy services in informal settlements: Case studies from South Africa and Zimbabwe," *Energy Res. Social Sci.*, vol. 56, Oct. 2019, Art. no. 101202.
- [112] P. A. Trotter and S. Abdullah, "Re-focusing foreign involvement in sub-saharan Africa's power sector on sustainable development," *Energy Sustain. Develop.*, vol. 44, pp. 139–146, Jun. 2018.
- [113] O. M. Babatunde, J. L. Munda, and Y. Hamam, "How can a low-income household procure small-scale hybrid renewable energy system?" *Int. J. Energy Sector Manage.*, vol. 13, no. 4, pp. 1149–1172, Nov. 2019.

- [114] I. Ozturk, "The dynamic relationship between agricultural sustainability and food-energy-water poverty in a panel of selected sub-saharan African countries," *Energy Policy*, vol. 107, pp. 289–299, Aug. 2017.
- [115] J. Gregory and B. K. Sovacool, "Rethinking the governance of energy poverty in sub-saharan Africa: Reviewing three academic perspectives on electricity infrastructure investment," *Renew. Sustain. Energy Rev.*, vol. 111, pp. 344–354, Sep. 2019.
- [116] C. G. Monyei, L. O. Oyedele, O. O. Akinade, A. O. Ajayi, and X. J. Luo, "Benchmarks for energy access: Policy vagueness and incoherence as barriers to sustainable electrification of the global south," *Energy Res. Social Sci.*, vol. 54, pp. 113–116, Aug. 2019.
- [117] F. O. Ogwumike and U. M. Ozughalu, "Analysis of energy poverty and its implications for sustainable development in Nigeria," *Environ. Develop. Econ.*, vol. 21, no. 3, pp. 273–290, Aug. 2015.
- [118] J.-J. Wang, Y.-Y. Jing, C.-F. Zhang, and J.-H. Zhao, "Review on multi-criteria decision analysis aid in sustainable energy decision-making," *Renew. Sustain. Energy Rev.*, vol. 13, no. 9, pp. 2263–2278, Dec. 2009.
- [119] A. Ishizaka and P. Nemery, *Multi-Criteria Decision Analysis: Methods and Software*. Hoboken, NJ, USA: Wiley, 2013.
- [120] J. Rezaei, "Best-worst multi-criteria decision-making method," *Omega*, vol. 53, pp. 49–57, Jun. 2015.
- [121] A. Kumar, B. Sah, A. R. Singh, Y. Deng, X. He, P. Kumar, and R. Bansal, "A review of multi criteria decision making (MCDM) towards sustainable renewable energy development," *Renew. Sustain. Energy Rev.*, vol. 69, pp. 596–609, Mar. 2017.
- [122] M. Marttunen, J. Lienert, and V. Belton, "Structuring problems for multi-criteria decision analysis in practice: A literature review of method combinations," *Eur. J. Oper. Res.*, vol. 263, no. 1, pp. 1–17, Nov. 2017.
- [123] O. M. Babatunde, O. S. Adedoja, D. E. Babatunde, and I. H. Denwigwe, "Off-grid hybrid renewable energy system for rural healthcare centers: A case study in Nigeria," *Energy Sci. Eng.*, vol. 7, no. 3, pp. 676–693, Mar. 2019.
- [124] O. Babatunde, D. Akinyele, T. Akinbulire, and P. Oluseyi, "Evaluation of a grid-independent solar photovoltaic system for primary health centres (PHCs) in developing countries," *Renew. Energy Focus*, vol. 24, pp. 16–27, Mar. 2018.
- [125] A. Maleki and F. Pourfayaz, "Optimal sizing of autonomous hybrid photovoltaic/wind/battery power system with LPSP technology by using evolutionary algorithms," *Sol. Energy*, vol. 115, pp. 471–483, May 2015.
- [126] B. S. Borowy and Z. M. Salameh, "Optimum photovoltaic array size for a hybrid wind/PV system," *IEEE Trans. Energy Convers.*, vol. 9, no. 3, pp. 482–488, Sep. 1994.
- [127] H. Yang, L. Lu, and W. Zhou, "A novel optimization sizing model for hybrid solar-wind power generation system," *Sol. Energy*, vol. 81, no. 1, pp. 76–84, Jan. 2007.
- [128] S. Diaf, D. Diaf, M. Belhamel, M. Haddadi, and A. Louche, "A methodology for optimal sizing of autonomous hybrid PV/wind system," *Energy Policy*, vol. 35, no. 11, pp. 5708–5718, Nov. 2007.
- [129] S. Diaf, G. Notton, M. Belhamel, M. Haddadi, and A. Louche, "Design and techno-economical optimization for hybrid PV/wind system under various meteorological conditions," *Appl. Energy*, vol. 85, no. 10, pp. 968–987, Oct. 2008.
- [130] H. Yang, Z. Wei, and L. Chengzhi, "Optimal design and techno-economic analysis of a hybrid solar-wind power generation system," *Appl. Energy*, vol. 86, no. 2, pp. 163–169, Feb. 2009.
- [131] H. Belmili, M. Haddadi, S. Bacha, M. F. Almi, and B. Bendib, "Sizing stand-alone photovoltaic-wind hybrid system: Techno-economic analysis and optimization," *Renew. Sustain. Energy Rev.*, vol. 30, pp. 821–832, Feb. 2014.
- [132] D. K. Khatod, V. Pant, and J. Sharma, "Analytical approach for well-being assessment of small autonomous power systems with solar and wind energy sources," *IEEE Trans. Energy Convers.*, vol. 25, no. 2, pp. 535–545, Jun. 2010.
- [133] P. S. Georgilakis and Y. A. Katsigiannis, "Reliability and economic evaluation of small autonomous power systems containing only renewable energy sources," *Renew. Energy*, vol. 34, no. 1, pp. 65–70, Jan. 2009.
- [134] A. N. Celik, "Techno-economic analysis of autonomous PV-wind hybrid energy systems using different sizing methods," *Energy Convers. Manage.*, vol. 44, no. 12, pp. 1951–1968, Jul. 2003.
- [135] A. Kaabeche, M. Belhamel, and R. Ibtouen, "Sizing optimization of grid-independent hybrid photovoltaic/wind power generation system," *Energy*, vol. 36, no. 2, pp. 1214–1222, Feb. 2011.
- [136] T. O. Akinbulire, P. O. Oluseyi, and O. M. Babatunde, "Techno-economic and environmental evaluation of demand side management techniques for rural electrification in Ibadan, Nigeria," *Int. J. Energy Environ. Eng.*, vol. 5, no. 4, pp. 375–385, Aug. 2014.
- [137] F. J. Ardakani, G. Riahy, and M. Abedi, "Optimal sizing of a grid-connected hybrid system for north-west of Iran-case study," in *Proc. 9th Int. Conf. Environ. Electr. Eng.*, 2010, pp. 29–32.
- [138] S. Upadhyay and M. P. Sharma, "Development of hybrid energy system with cycle charging strategy using particle swarm optimization for a remote area in India," *Renew. Energy*, vol. 77, pp. 586–598, May 2015.
- [139] A. B. Kanase-Patil, R. P. Saini, and M. P. Sharma, "Development of IREOM model based on seasonally varying load profile for hilly remote areas of Uttarakhand state in India," *Energy*, vol. 36, no. 9, pp. 5690–5702, Sep. 2011.
- [140] S. H. Karaki, R. B. Chedid, and R. Ramadan, "Probabilistic performance assessment of autonomous solar-wind energy conversion systems," *IEEE Trans. Energy Convers.*, vol. 14, no. 3, pp. 766–772, Sep. 1999.
- [141] G. Tina, S. Gagliano, and S. Raiti, "Hybrid solar/wind power system probabilistic modelling for long-term performance assessment," *Sol. Energy*, vol. 80, no. 5, pp. 578–588, May 2006.
- [142] E. Hirst and M. Schweitzer, "Electric-utility resource planning and decision-making: The importance of uncertainty," *Risk Anal.*, vol. 10, no. 1, pp. 137–146, Mar. 1990.
- [143] M. Ghofrani and N. N. Hosseini, "Optimizing hybrid renewable energy systems: A review," in *Sustainable Energy-Technological Issues, Applications and Case Studies*. London, U.K.: IntechOpen, 2016.
- [144] R. Ramakumar, I. Abouzahr, and K. Ashenayi, "A knowledge-based approach to the design of integrated renewable energy systems," *IEEE Trans. Energy Convers.*, vol. 7, no. 4, pp. 648–659, Dec. 1992.
- [145] A. K. Akella, M. P. Sharma, and R. P. Saini, "Optimum utilization of renewable energy sources in a remote area," *Renew. Sustain. Energy Rev.*, vol. 11, no. 5, pp. 894–908, Jun. 2007.
- [146] J. C. Hennet and M. T. Samarakou, "Optimization of a combined wind and solar power plant," *Int. J. Energy Res.*, vol. 10, no. 2, pp. 181–188, Apr. 1986.
- [147] A. Gupta, R. P. Saini, and M. P. Sharma, "Optimised application of hybrid renewable energy system in rural electrification," in *Proc. India Int. Conf. Power Electron.*, Dec. 2006, pp. 337–340.
- [148] A. B. Kanase-Patil, R. P. Saini, and M. P. Sharma, "Integrated renewable energy systems for off grid rural electrification of remote area," *Renew. Energy*, vol. 35, no. 6, pp. 1342–1349, Jun. 2010.
- [149] A. C. Nagabhushana, R. Jyoti, and A. B. Raju, "Economic analysis and comparison of proposed HRES for stand-alone applications at various places in Karnataka state," in *Proc. ISGT-India*, Dec. 2011, pp. 380–385.
- [150] M. Hancock, H. R. Outhred, and R. J. Kaye, "A new method for optimising the operation of stand-alone PV hybrid power systems," in *Proc. IEEE 1st World Conf. Photovoltaic Energy Convers. (A Joint Conf. WCPEC, PVSC, PVSEC PSEC)*, vol. 1, Dec. 1994, pp. 1188–1191.
- [151] T. K. Das, D. Chakraborty, and S. Seth, "Energy consumption and prospects for renewable energy technologies in an Indian village," *Energy*, vol. 15, no. 5, pp. 445–449, May 1990.
- [152] S. Ashok, "Optimised model for community-based hybrid energy system," *Renew. Energy*, vol. 32, no. 7, pp. 1155–1164, Jun. 2007.
- [153] A. El-Zeftawy and A. A. El-Ela, "Optimal planning of wind-Diesel generation units in an isolated area," *Electr. Power Syst. Res.*, vol. 22, no. 1, pp. 27–33, 1991.
- [154] Y. Nian, S. Liu, D. Wu, and J. Liu, "A method for optimal sizing of stand-alone hybrid PV/wind/battery system," in *Proc. 2nd IET Renew. Power Gener. Conf. (RPG)*, 2013, pp. 2–62.
- [155] Z. W. Geem, "Size optimization for a hybrid photovoltaic-wind energy system," *Int. J. Electr. Power Energy Syst.*, vol. 42, no. 1, pp. 448–451, 2012.
- [156] M. Giuntoli and D. Poli, "Optimized thermal and electrical scheduling of a large scale virtual power plant in the presence of energy storages," *IEEE Trans. Smart Grid*, vol. 4, no. 2, pp. 942–955, Jun. 2013.
- [157] S. Makkonen and R. Lahdelma, "Non-convex power plant modelling in energy optimisation," *Eur. J. Oper. Res.*, vol. 171, no. 3, pp. 1113–1126, Jun. 2006.
- [158] K. B. Aviso, J.-Y. Lee, and R. Tan, "A p-graph model for multi-period optimization of isolated energy systems," *Chem. Eng. Trans.*, vol. 52, pp. 865–870, 2016.

- [159] S. Niyan, L. Suganthi, and T. R. Jagadeesan, "Renewable energy planning for India in 21st century," *Renew. Energy*, vol. 14, nos. 1–4, pp. 453–457, May 1998.
- [160] S. Niyan and K. Sumathy, "An optimal renewable energy model for various end-uses," *Energy*, vol. 25, no. 6, pp. 563–575, 2000.
- [161] L. Standardi, "Economic model predictive control for large-scale and distributed energy systems," Tech. Univ. Denmark, Lyngby, Denmark, Tech. Rep., 2015. [Online]. Available: https://backend.orbit.dtu.dk/ws/portalfiles/portal/107807607/phd356_Standardi_L.pdf
- [162] S. Deshmukh and M. Deshmukh, "A new approach to micro-level energy planning—A case of northern parts of Rajasthan, India," *Renew. Sustain. Energy Rev.*, vol. 13, no. 3, pp. 634–642, 2009.
- [163] X. Hu, K. J. Tseng, and M. Srinivasan, "Optimization of battery energy storage system with super-capacitor for renewable energy applications," in *Proc. 8th Int. Conf. Power Electron. (ECCE Asia)*, May 2011, pp. 1552–1557.
- [164] G. Contaxis, J. Kabouris, and J. Chadjivassiliadis, "Optimum operation of an autonomous energy system," in *Proc. EWECC*, Oct. 1986, pp. 97–98.
- [165] S. Bandaru and K. Deb, "Metaheuristic techniques," in *Decision Sciences*. Boca Raton, FL, USA: CRC Press, 2016, pp. 693–750.
- [166] O. Oyeboade and D. E. Ighravve, "Urban water demand forecasting: A comparative evaluation of conventional and soft computing techniques," *Resources*, vol. 8, no. 3, p. 156, Sep. 2019.
- [167] O. Oyeboade and D. Stretch, "Neural network modeling of hydrological systems: A review of implementation techniques," *Natural Resource Model.*, vol. 32, no. 1, Sep. 2018, Art. no. e12189.
- [168] O. Oyeboade, D. E. Babatunde, C. G. Monyei, and O. M. Babatunde, "Water demand modelling using evolutionary computation techniques: Integrating water equity and justice for realization of the sustainable development goals," *Heliyon*, vol. 5, no. 11, Nov. 2019, Art. no. e02796.
- [169] W. Zhang, A. Maleki, M. A. Rosen, and J. Liu, "Optimization with a simulated annealing algorithm of a hybrid system for renewable energy including battery and hydrogen storage," *Energy*, vol. 163, pp. 191–207, Nov. 2018.
- [170] S. Sanajaoba Singh and E. Fernandez, "Modeling, size optimization and sensitivity analysis of a remote hybrid renewable energy system," *Energy*, vol. 143, pp. 719–731, Jan. 2018.
- [171] P. Paliwal, N. P. Patidar, and R. K. Nema, "Determination of reliability constrained optimal resource mix for an autonomous hybrid power system using particle swarm optimization," *Renew. Energy*, vol. 63, pp. 194–204, Mar. 2014.
- [172] H. Borhanazad, S. Mekhilef, V. G. Ganapathy, M. Modiri-Delshad, and A. Mirtaheri, "Optimization of micro-grid system using MOPSO," *Renew. Energy*, vol. 71, pp. 295–306, Nov. 2014.
- [173] S. Safari, M. M. Ardehali, and M. J. Sirizi, "Particle swarm optimization based fuzzy logic controller for autonomous green power energy system with hydrogen storage," *Energy Convers. Manage.*, vol. 65, pp. 41–49, Jan. 2013.
- [174] A. Hassan, M. Kandil, M. Saadawi, and M. Saeed, "Modified particle swarm optimisation technique for optimal design of small renewable energy system supplying a specific load at Mansoura university," *IET Renew. Power Gener.*, vol. 9, no. 5, pp. 474–483, Jul. 2015.
- [175] A. Maleki, M. Ameri, and F. Keynia, "Scrutiny of multifarious particle swarm optimization for finding the optimal size of a PV/wind/battery hybrid system," *Renew. Energy*, vol. 80, pp. 552–563, Aug. 2015.
- [176] H. R. Baghaee, M. Mirsalim, G. B. Gharehpetian, and H. A. Talebi, "Reliability/cost-based multi-objective Pareto optimal design of stand-alone wind/PV/FC generation microgrid system," *Energy*, vol. 115, pp. 1022–1041, Nov. 2016.
- [177] A. Askarzadeh and L. dos Santos Coelho, "A novel framework for optimization of a grid independent hybrid renewable energy system: A case study of Iran," *Sol. Energy*, vol. 112, pp. 383–396, Feb. 2015.
- [178] V. M. Sanchez, A. U. Chavez-Ramirez, S. M. Duron-Torres, J. Hernandez, L. G. Arriaga, and J. M. Ramirez, "Techno-economical optimization based on swarm intelligence algorithm for a stand-alone wind-photovoltaic-hydrogen power system at south-east region of Mexico," *Int. J. Hydrogen Energy*, vol. 39, no. 29, pp. 16646–16655, Oct. 2014.
- [179] B. Zhao, X. Zhang, P. Li, K. Wang, M. Xue, and C. Wang, "Optimal sizing, operating strategy and operational experience of a stand-alone microgrid on dongfushan island," *Appl. Energy*, vol. 113, pp. 1656–1666, Jan. 2014.
- [180] A. S. O. Ogunjuyigbe, T. R. Ayodele, and O. A. Akinola, "Optimal allocation and sizing of PV/wind/split-diesel/battery hybrid energy system for minimizing life cycle cost, carbon emission and dump energy of remote residential building," *Appl. Energy*, vol. 171, pp. 153–171, Jun. 2016.
- [181] S. Rajanna and R. P. Saini, "Development of optimal integrated renewable energy model with battery storage for a remote Indian area," *Energy*, vol. 111, pp. 803–817, Sep. 2016.
- [182] B. Elliston, I. Macgill, and M. Diesendorf, "Least cost 100% renewable electricity scenarios in the Australian national electricity market," *Energy Policy*, vol. 59, pp. 270–282, 2013.
- [183] L. K. Gan, J. K. H. Shek, and M. A. Mueller, "Optimised operation of an off-grid hybrid wind-diesel-battery system using genetic algorithm," *Energy Convers. Manage.*, vol. 126, pp. 446–462, Oct. 2016.
- [184] G. Merei, C. Berger, and D. U. Sauer, "Optimization of an off-grid hybrid PV–wind–diesel system with different battery technologies using genetic algorithm," *Sol. Energy*, vol. 97, pp. 460–473, Nov. 2013.
- [185] E. Koutroulis, D. Kolokotsa, A. Potirakis, and K. Kalaitzakis, "Methodology for optimal sizing of stand-alone photovoltaic/wind-generator systems using genetic algorithms," *Sol. Energy*, vol. 80, no. 9, pp. 1072–1088, Sep. 2006.
- [186] E. Koutroulis and D. Kolokotsa, "Design optimization of desalination systems power-supplied by PV and W/G energy sources," *Desalination*, vol. 258, nos. 1–3, pp. 171–181, Aug. 2010.
- [187] J. Zeng, M. Li, J. F. Liu, J. Wu, and H. W. Ngan, "Operational optimization of a stand-alone hybrid renewable energy generation system based on an improved genetic algorithm," in *Proc. IEEE PES Gen. Meeting*, Jul. 2010, pp. 1–6.
- [188] P. Suhane, S. Rangnekar, A. Khare, and A. Mittal, "Sizing and performance analysis of standalone wind-photovoltaic based hybrid energy system using ant colony optimisation," *IET Renew. Power Gener.*, vol. 10, no. 7, pp. 964–972, Aug. 2016.
- [189] A. Fetanat and E. Khorasaninejad, "Size optimization for hybrid photovoltaic–wind energy system using ant colony optimization for continuous domains based integer programming," *Appl. Soft Comput.*, vol. 31, pp. 196–209, Jun. 2015.
- [190] W. Dong, Y. Li, and J. Xiang, "Sizing of a stand-alone photovoltaic/wind energy system with hydrogen and battery storage based on improved ant colony algorithm," in *Proc. Chin. Control Decis. Conf. (CCDC)*, May 2016, pp. 4461–4466.
- [191] S. Kumar and N. S. Pal, "Ant colony optimization for less power consumption and fast charging of battery in solar grid system," in *Proc. 4th IEEE Uttar Pradesh Sect. Int. Conf. Electr., Comput. Electron. (UPCON)*, Oct. 2017, pp. 244–249.
- [192] J. Zhao and X. Yuan, "Multi-objective optimization of stand-alone hybrid PV-wind-diesel-battery system using improved fruit fly optimization algorithm," *Soft Comput.*, vol. 20, no. 7, pp. 2841–2853, Apr. 2015.
- [193] S. Singh, M. Singh, and S. C. Kaushik, "Feasibility study of an islanded microgrid in rural area consisting of PV, wind, biomass and battery energy storage system," *Energy Convers. Manage.*, vol. 128, pp. 178–190, Nov. 2016.
- [194] M. Kefayat, A. L. Ara, and S. A. N. Niaki, "A hybrid of ant colony optimization and artificial bee colony algorithm for probabilistic optimal placement and sizing of distributed energy resources," *Energy Convers. Manage.*, vol. 92, pp. 149–161, Mar. 2015.
- [195] X. Liu, Z. Du, and X. Yan, "Optimal sizing of distributed energy in AC/DC hybrid stand-alone micro-grid using modified artificial bee colony algorithm," in *Proc. 6th Int. Conf. Machinery, Mater., Environ., Biotechnol. Comput. (MMEBC)*, Tianjin, China, Jun. 2016.
- [196] H. Shayeghi, M. Moradzadeh, Y. Hashemi, M. Saif, and L. Vandevelde, "Wind-PV-storage optimal environmental design using multi-objective artificial bee colony," in *Proc. IEEE PES Asia–Pacific Power Energy Eng. Conf. (APPEEC)*, Nov. 2015, pp. 1–5.
- [197] S. Goyal, S. Mishra, and A. Bhatia, "Optimization of size of PV/wind/biodiesel by using artificial bee colony (ABC) algorithm," in *Proc. Recent Develop. Control, Autom. Power Eng. (RDCAPE)*, Oct. 2017, pp. 220–223.
- [198] A. Maleki and A. Askarzadeh, "Artificial bee swarm optimization for optimum sizing of a stand-alone PV/WT/FC hybrid system considering LPSP concept," *Sol. Energy*, vol. 107, pp. 227–235, Sep. 2014.
- [199] A. Maleki and A. Askarzadeh, "Optimal sizing of a PV/wind/diesel system with battery storage for electrification to an off-grid remote region: A case study of Rafsanjan, Iran," *Sustain. Energy Technol. Assessments*, vol. 7, pp. 147–153, Sep. 2014.

- [200] R. Kumar, R. A. Gupta, and A. K. Bansal, "Economic analysis and power management of a stand-alone wind/photovoltaic hybrid energy system using biogeography based optimization algorithm," *Swarm Evol. Comput.*, vol. 8, pp. 33–43, Feb. 2013.
- [201] A. K. Bansal, R. Kumar, and R. A. Gupta, "Economic analysis and power management of a small autonomous hybrid power system (SAHPS) using biogeography based optimization (BBO) algorithm," *IEEE Trans. Smart Grid*, vol. 4, no. 1, pp. 638–648, Mar. 2013.
- [202] R. A. Gupta, R. Kumar, and A. K. Bansal, "BBO-based small autonomous hybrid power system optimization incorporating wind speed and solar radiation forecasting," *Renew. Sustain. Energy Rev.*, vol. 41, pp. 1366–1375, Jan. 2015.
- [203] H. Gharavi, M. M. Ardehali, and S. Ghanbari-Tichi, "Imperial competitive algorithm optimization of fuzzy multi-objective design of a hybrid green power system with considerations for economics, reliability, and environmental emissions," *Renew. Energy*, vol. 78, pp. 427–437, Jun. 2015.
- [204] A. Fathy, "A reliable methodology based on mine blast optimization algorithm for optimal sizing of hybrid PV-wind-FC system for remote area in Egypt," *Renew. Energy*, vol. 95, pp. 367–380, Sep. 2016.
- [205] X.-R. Chen, J.-Q. Li, Y. Han, B. Niu, L. Liu, and B. Zhang, "An improved brain storm optimization for a hybrid renewable energy system," *IEEE Access*, vol. 7, pp. 49513–49526, 2019.
- [206] H. Energy, *Homer Pro Version 3.7 User Manual*. HOMER Energy: Boulder, CO, USA, 2016.
- [207] E. I. Baring-Gould, "Hybrid2, the hybrid system simulation model: User manual. Version 1.0," Nat. Renew. Energy Lab., Golden, CO, USA, Tech. Rep., 1996.
- [208] R. D. López, *iHOGA Version 2.5 User's Manual*. Accessed: Nov. 14, 2019. [Online]. Available: <https://ihoga.unizar.es/Desc/iHOGA%202.5%20User%20manual.pdf#>
- [209] D. Connolly, H. Lund, B. V. Mathiesen, and M. Leahy, "A review of computer tools for analysing the integration of renewable energy into various energy systems," *Appl. Energy*, vol. 87, no. 4, pp. 1059–1082, Apr. 2010.
- [210] Natural Resources Canada. *RETScreen*. Accessed: Nov. 14, 2019. [Online]. Available: <https://www.nrcan.gc.ca/energy/retscreen/7465#>
- [211] T. Berrill, *Hybrids*. Wellington Point, QLD, Australia: Solaris Solar Powered Home, 2005, p. 29.
- [212] F. M. Irena, "Investment frameworks for renewables in developing countries," Internal Renew. Energy Agency, Masdar City, United Arab Emirates, Tech. Rep., 2012.
- [213] R. Nepal, "Roles and potentials of renewable energy in less-developed economies: The case of nepal," *Renew. Sustain. Energy Rev.*, vol. 16, no. 4, pp. 2200–2206, May 2012.
- [214] D. O. Akinyele, "Techno-economic and life-cycle impact analysis of solar photovoltaic microgrid systems for off-grid communities," Victoria Univ. Wellington, Wellington, New Zealand, Tech. Rep., 2016. [Online]. Available: <http://www.researcharchive.vuw.ac.nz>
- [215] U. Damisa, N. I. Nwulu, and Y. Sun, "Microgrid energy and reserve management incorporating prosumer behind-the-meter resources," *IET Renew. Power Gener.*, vol. 12, no. 8, pp. 910–919, Jun. 2018.
- [216] S. M. Shaahid and I. El-Amin, "Techno-economic evaluation of off-grid hybrid photovoltaic–diesel–battery power systems for rural electrification in Saudi Arabia—A way forward for sustainable development," *Renew. Sustain. Energy Rev.*, vol. 13, no. 3, pp. 625–633, Apr. 2009.
- [217] Alternative Energy. (2013). *Solar Energy for Low Income Group*. [Online]. Available: <http://www.altenergy.org/renewables/solar/solar-energy-for-low-income.html>
- [218] A. Chatterjee, D. Burmester, A. Brent, and R. Rayudu, "Research insights and knowledge headways for developing remote, off-grid microgrids in developing countries," *Energies*, vol. 12, no. 10, p. 2008, May 2019.
- [219] S. Bhakta, V. Mukherjee, and B. Shaw, "Techno-economic analysis and performance assessment of standalone photovoltaic/wind/hybrid power system in Lakshadweep islands of India," *J. Renew. Sustain. Energy*, vol. 7, no. 6, Nov. 2015, Art. no. 063117.
- [220] M. Bashir and J. Sadeh, "Optimal sizing of hybrid wind/photovoltaic/battery considering the uncertainty of wind and photovoltaic power using Monte Carlo," in *Proc. 11th Int. Conf. Environ. Electr. Eng.*, May 2012, pp. 1081–1086.
- [221] T. Khatib, A. Mohamed, and K. Sopian, "Optimization of a PV/wind micro-grid for rural housing electrification using a hybrid iterative/genetic algorithm: Case study of Kuala Terengganu, Malaysia," *Energy Buildings*, vol. 47, pp. 321–331, Apr. 2012.
- [222] R. K. Rajkumar, V. K. Ramchandaramurthy, B. L. Yong, and D. B. Chia, "Techno-economical optimization of hybrid PV/wind/battery system using neuro-fuzzy," *Energy*, vol. 36, no. 8, pp. 5148–5153, Aug. 2011.
- [223] A. R. Abbasi and A. R. Seifi, "Energy expansion planning by considering electrical and thermal expansion simultaneously," *Energy Convers. Manage.*, vol. 83, pp. 9–18, Jul. 2014.
- [224] M. Das, M. A. K. Singh, and A. Biswas, "Techno-economic optimization of an off-grid hybrid renewable energy system using metaheuristic optimization approaches—case of a radio transmitter station in India," *Energy Convers. Manage.*, vol. 185, pp. 339–352, Apr. 2019.
- [225] R. Singh, R. C. Bansal, A. R. Singh, and R. Naidoo, "Multi-objective optimization of hybrid renewable energy system using reformed electric system cascade analysis for islanding and grid connected modes of operation," *IEEE Access*, vol. 6, pp. 47332–47354, 2018.
- [226] A. M. Patel and S. K. Singal, "Economic analysis of integrated renewable energy system for electrification of remote rural area having scattered population," *Int. J. Renew. Energy Res.*, vol. 8, no. 1, pp. 523–539, 2018.
- [227] M. R. Elkadeem, S. Wang, S. W. Sharshir, and E. G. Atia, "Feasibility analysis and techno-economic design of grid-isolated hybrid renewable energy system for electrification of agriculture and irrigation area: A case study in Dongola, sudan," *Energy Convers. Manage.*, vol. 196, pp. 1453–1478, Sep. 2019.
- [228] M. Guezgouz, J. Jurasz, B. Bekkouche, T. Ma, M. S. Javed, and A. Kies, "Optimal hybrid pumped hydro–battery storage scheme for off-grid renewable energy systems," *Energy Convers. Manage.*, vol. 199, Nov. 2019, Art. no. 112046.
- [229] A. Kasaiean, A. Razmjoo, R. Shirmohammadi, F. Pourfayaz, and A. Sumper, "Deployment of a stand-alone hybrid renewable energy system in coastal areas as a reliable energy source," *Environ. Prog. Sustain. Energy*, 2019, Art. no. e13354.
- [230] S. Makhdoomi and A. Askarzadeh, "Optimizing operation of a photovoltaic/diesel generator hybrid energy system with pumped hydro storage by a modified crow search algorithm," *J. Energy Storage*, vol. 27, Feb. 2020, Art. no. 101040.
- [231] C. S. Lai, G. Locatelli, A. Pimm, Y. Tao, X. Li, and L. L. Lai, "A financial model for lithium-ion storage in a photovoltaic and biogas energy system," *Appl. Energy*, vol. 251, Oct. 2019, Art. no. 113179.
- [232] A. Thornton, S.-J. Kim, and S. Kara, "Sizing a hybrid renewable energy system to reduce energy costs at various levels of robustness for an industrial site," *Procedia CIRP*, vol. 69, pp. 371–376, 2018.
- [233] W. Ma, X. Xue, G. Liu, and R. Zhou, "Techno-economic evaluation of a community-based hybrid renewable energy system considering site-specific nature," *Energy Convers. Manage.*, vol. 171, pp. 1737–1748, Sep. 2018.
- [234] I. Padrón, D. Avila, G. N. Marichal, and J. A. Rodríguez, "Assessment of hybrid renewable energy systems to supplied energy to autonomous desalination systems in two islands of the canary archipelago," *Renew. Sustain. Energy Rev.*, vol. 101, pp. 221–230, Mar. 2019.
- [235] D. Guangqian, K. Bekhrad, P. Azarikhah, and A. Maleki, "A hybrid algorithm based optimization on modeling of grid independent biodiesel-based hybrid solar/wind systems," *Renew. Energy*, vol. 122, pp. 551–560, Jul. 2018.
- [236] J. Ahmad, M. Imran, A. Khalid, W. Iqbal, S. R. Ashraf, M. Adnan, S. F. Ali, K. S. Khokhar, "Techno economic analysis of a wind-photovoltaic-biomass hybrid renewable energy system for rural electrification: A case study of Kallar Kahar," *Energy*, vol. 148, pp. 208–234, Apr. 2018.
- [237] A. Khosravi, R. N. N. Koury, L. Machado, and J. J. G. Pabon, "Energy, exergy and economic analysis of a hybrid renewable energy with hydrogen storage system," *Energy*, vol. 148, pp. 1087–1102, Apr. 2018.
- [238] L. Olatomiwa, R. Blanchard, S. Mekhilef, and D. Akinyele, "Hybrid renewable energy supply for rural healthcare facilities: An approach to quality healthcare delivery," *Sustain. Energy Technol. Assessments*, vol. 30, pp. 121–138, Dec. 2018.
- [239] H. Bakhtiari and R. A. Naghizadeh, "Multi-criteria optimal sizing of hybrid renewable energy systems including wind, photovoltaic, battery, and hydrogen storage with ϵ -constraint method," *IET Renew. Power Gener.*, vol. 12, no. 8, pp. 883–892, Jun. 2018.

- [240] M. M. Samy, S. Barakat, and H. S. Ramadan, "A flower pollination optimization algorithm for an off-grid PV-fuel cell hybrid renewable system," *Int. J. Hydrogen Energy*, vol. 44, no. 4, pp. 2141–2152, Jan. 2019.
- [241] L. G. Acuña, M. Lake, R. V. Padilla, Y. Y. Lim, E. G. Ponzón, and Y. C. S. Too, "Modelling autonomous hybrid photovoltaic-wind energy systems under a new reliability approach," *Energy Convers. Manage.*, vol. 172, pp. 357–369, Sep. 2018.
- [242] M. Edwin and S. Joseph Sekhar, "Techno-Economic evaluation of milk chilling unit retrofitted with hybrid renewable energy system in coastal province," *Energy*, vol. 151, pp. 66–78, May 2018.
- [243] M. Mehrpooya, M. Mohammadi, and E. Ahmadi, "Techno-economic-environmental study of hybrid power supply system: A case study in Iran," *Sustain. Energy Technol. Assessments*, vol. 25, pp. 1–10, Feb. 2018.
- [244] A. B. Forough and R. Roshandel, "Lifetime optimization framework for a hybrid renewable energy system based on receding horizon optimization," *Energy*, vol. 150, pp. 617–630, May 2018.
- [245] J. B. Fulzele and M. B. Daigavane, "Design and optimization of hybrid PV-wind renewable energy system," *Mater. Today, Proc.*, vol. 5, no. 1, pp. 810–818, 2018.
- [246] F. Fodhil, A. Hamidat, and O. Nadjemi, "Potential, optimization and sensitivity analysis of photovoltaic-diesel-battery hybrid energy system for rural electrification in Algeria," *Energy*, vol. 169, pp. 613–624, Feb. 2019.
- [247] D. N. Luta and A. K. Raji, "Optimal sizing of hybrid fuel cell-supercapacitor storage system for off-grid renewable applications," *Energy*, vol. 166, pp. 530–540, Jan. 2019.
- [248] A. Maleki, "Design and optimization of autonomous solar-wind-reverse osmosis desalination systems coupling battery and hydrogen energy storage by an improved bee algorithm," *Desalination*, vol. 435, pp. 221–234, Jun. 2018.
- [249] F. Baghdadi, K. Mohammadi, S. Diaf, and O. Behar, "Feasibility study and energy conversion analysis of stand-alone hybrid renewable energy system," *Energy Convers. Manage.*, vol. 105, pp. 471–479, Nov. 2015.
- [250] A. Kamjoo, A. Maheri, A. M. Dizqah, and G. A. Putrus, "Multi-objective design under uncertainties of hybrid renewable energy system using NSGA-II and chance constrained programming," *Int. J. Electr. Power Energy Syst.*, vol. 74, pp. 187–194, Jan. 2016.
- [251] M. L. Kolhe, K. M. I. U. Ranaweera, and A. G. B. S. Gunawardana, "Techno-economic sizing of off-grid hybrid renewable energy system for rural electrification in sri lanka," *Sustain. Energy Technol. Assessments*, vol. 11, pp. 53–64, Sep. 2015.
- [252] Y. Kalinci, A. Hepbasli, and I. Dincer, "Techno-economic analysis of a stand-alone hybrid renewable energy system with hydrogen production and storage options," *Int. J. Hydrogen Energy*, vol. 40, no. 24, pp. 7652–7664, Jun. 2015.
- [253] V. Khare, S. Nema, and P. Baredar, "Optimisation of the hybrid renewable energy system by HOMER, PSO and CPSO for the study area," *Int. J. Sustain. Energy*, vol. 36, no. 4, pp. 326–343, Mar. 2015.
- [254] A. Maleki, M. G. Khajeh, and M. Ameri, "Optimal sizing of a grid independent hybrid renewable energy system incorporating resource uncertainty, and load uncertainty," *Int. J. Electr. Power Energy Syst.*, vol. 83, pp. 514–524, Dec. 2016.
- [255] J. Barzola, M. Espinoza, and F. Cabrera, "Analysis of hybrid solar/wind/diesel renewable energy system for off-grid rural electrification," *Int. J. Renew. Energy Res.*, vol. 6, no. 3, pp. 1146–1152, 2016.
- [256] S. Rajanna and R. P. Saini, "Modeling of integrated renewable energy system for electrification of a remote area in India," *Renew. Energy*, vol. 90, pp. 175–187, May 2016.
- [257] X. Wang, A. Palazoglu, and N. H. El-Farra, "Operational optimization and demand response of hybrid renewable energy systems," *Appl. Energy*, vol. 143, pp. 324–335, Apr. 2015.
- [258] S. R. Tito, T. T. Lie, and T. N. Anderson, "Optimal sizing of a wind-photovoltaic-battery hybrid renewable energy system considering socio-demographic factors," *Sol. Energy*, vol. 136, pp. 525–532, Oct. 2016.
- [259] M. M. Rahman, M. M.-U.-H. Khan, M. A. Ullah, X. Zhang, and A. Kumar, "A hybrid renewable energy system for a north American off-grid community," *Energy*, vol. 97, pp. 151–160, Feb. 2016.
- [260] S. Salehin, M. T. Ferdaous, R. M. Chowdhury, S. S. Shithi, M. S. R. B. Rofi, and M. A. Mohammed, "Assessment of renewable energy systems combining techno-economic optimization with energy scenario analysis," *Energy*, vol. 112, pp. 729–741, Oct. 2016.
- [261] A. Singh, P. Baredar, and B. Gupta, "Techno-economic feasibility analysis of hydrogen fuel cell and solar photovoltaic hybrid renewable energy system for academic research building," *Energy Convers. Manage.*, vol. 145, pp. 398–414, Aug. 2017.
- [262] H. S. Das, A. Dey, C. W. Tan, and A. Yatim, "Feasibility analysis of standalone pv/wind/battery hybrid energy system for rural Bangladesh," *Int. J. Renew. Energy Res. (IJRER)*, vol. 6, no. 2, pp. 402–412, 2016.
- [263] O. V. Marchenko and S. V. Solomin, "Modeling of hydrogen and electrical energy storages in wind/PV energy system on the lake baikal coast," *Int. J. Hydrogen Energy*, vol. 42, no. 15, pp. 9361–9370, Apr. 2017.
- [264] A. Maleki, F. Pourfayaz, and M. A. Rosen, "A novel framework for optimal design of hybrid renewable energy-based autonomous energy systems: A case study for Namin, Iran," *Energy*, vol. 98, pp. 168–180, Mar. 2016.
- [265] S. A. Shezan, S. Julai, M. A. Kibria, K. R. Ullah, R. Saidur, W. T. Chong, and R. K. Akikur, "Performance analysis of an off-grid wind-PV (photovoltaic)-diesel-battery hybrid energy system feasible for remote areas," *J. Cleaner Prod.*, vol. 125, pp. 121–132, Jul. 2016.
- [266] T. Ma, H. Yang, and L. Lu, "Development of hybrid battery-supercapacitor energy storage for remote area renewable energy systems," *Appl. Energy*, vol. 153, pp. 56–62, Sep. 2015.
- [267] S. Aissou, D. Rekioua, N. Mezzai, T. Rekioua, and S. Bacha, "Modeling and control of hybrid photovoltaic wind power system with battery storage," *Energy Convers. Manage.*, vol. 89, pp. 615–625, Jan. 2015.
- [268] E. O. Diemuodeke, S. Hamilton, and A. Addo, "Multi-criteria assessment of hybrid renewable energy systems for Nigeria's coastline communities," *Energy, Sustainability Soc.*, vol. 6, no. 1, p. 26, Sep. 2016.
- [269] Y. V. Pavan Kumar and R. Bhimasingu, "Renewable energy based microgrid system sizing and energy management for green buildings," *J. Modern Power Syst. Clean Energy*, vol. 3, no. 1, pp. 1–13, Jan. 2015.
- [270] H. Shahinzadeh, A. Gheiratmand, S. H. Fathi, and J. Moradi, "Optimal design and management of isolated hybrid renewable energy system (WT/PV/ORES)," in *Proc. 21st Conf. Electr. Power Distrib. Netw. Conf. (EPDC)*, Apr. 2016, pp. 208–215.
- [271] R. Atia and N. Yamada, "Sizing and analysis of renewable energy and battery systems in residential microgrids," *IEEE Trans. Smart Grid*, vol. 7, no. 3, pp. 1204–1213, May 2016.
- [272] A. Chauhan and R. P. Saini, "Renewable energy based off-grid rural electrification in Uttarakhand state of India: Technology options, modelling method, barriers and recommendations," *Renew. Sustain. Energy Rev.*, vol. 51, pp. 662–681, Nov. 2015.
- [273] D. Tsuanyo, Y. Azoumah, D. Aussel, and P. Neveu, "Modeling and optimization of batteryless hybrid PV (photovoltaic)/Diesel systems for off-grid applications," *Energy*, vol. 86, pp. 152–163, Jun. 2015.
- [274] F. Diab, H. Lan, L. Zhang, and S. Ali, "An environmentally-friendly tourist village in Egypt based on a hybrid renewable energy system—Part one: What is the optimum city?" *Energies*, vol. 8, no. 7, pp. 6926–6944, Jul. 2015.
- [275] M. S. Ismail, M. Moghavvemi, and T. M. I. Mahlia, "Genetic algorithm based optimization on modeling and design of hybrid renewable energy systems," *Energy Convers. Manage.*, vol. 85, pp. 120–130, Sep. 2014.
- [276] C. Goodbody, E. Walsh, K. P. McDonnell, and P. Owende, "Regional integration of renewable energy systems in Ireland—The role of hybrid energy systems for small communities," *Int. J. Electr. Power Energy Syst.*, vol. 44, no. 1, pp. 713–720, Jan. 2013.
- [277] A. Rohani, K. Mazlumi, and H. Kord, "Modeling of a hybrid power system for economic analysis and environmental impact in HOMER," in *Proc. 18th Iranian Conf. Electr. Eng.*, May 2010, pp. 819–823.
- [278] Z. Iverson, A. Achuthan, P. Marzocca, and D. Aidun, "Optimal design of hybrid renewable energy systems (HRES) using hydrogen storage technology for data center applications," *Renew. Energy*, vol. 52, pp. 79–87, Apr. 2013.
- [279] U. Sureshkumar, P. Manoharan, and A. Ramalakshmi, "Economic cost analysis of hybrid renewable energy system using Homer," in *Proc. IEEE-Int. Conf. Adv. Eng., Sci. And Manage. (ICAESM)*, Mar. 2012, pp. 94–99.
- [280] N. Mezzai, D. Rekioua, T. Rekioua, A. Mohammadi, K. Idjdarane, and S. Bacha, "Modeling of hybrid photovoltaic/wind/fuel cells power system," *Int. J. Hydrogen Energy*, vol. 39, no. 27, pp. 15158–15168, Sep. 2014.
- [281] B. E. Türkay and A. Y. Telli, "Economic analysis of stand-alone and grid connected hybrid energy systems," *Renew. Energy*, vol. 36, no. 7, pp. 1931–1943, Jul. 2011.

- [282] M. Kolhe, K. M. I. Ranaweera, and A. G. B. S. Gunawardana, "Techno-economic analysis of off-grid hybrid renewable energy system for Sri Lanka," in *Proc. 7th Int. Conf. Inf. Autom. Sustainability*, Dec. 2014, pp. 1–5.
- [283] A. M. A. Haidar, P. N. John, and M. Shawal, "Optimal configuration assessment of renewable energy in Malaysia," *Renew. Energy*, vol. 36, no. 2, pp. 881–888, Feb. 2011.
- [284] L. A. Wong, V. K. Ramachandaramurthy, P. Taylor, J. B. Ekanayake, S. L. Walker, and S. Padmanaban, "Review on the optimal placement, sizing and control of an energy storage system in the distribution network," *J. Energy Storage*, vol. 21, pp. 489–504, Feb. 2019.
- [285] J. M. Lujano-Rojas, R. Dufo-López, and J. L. Bernal-Agustín, "Probabilistic modelling and analysis of stand-alone hybrid power systems," *Energy*, vol. 63, pp. 19–27, Dec. 2013.
- [286] K.-H. Chang and G. Lin, "Optimal design of hybrid renewable energy systems using simulation optimization," *Simul. Model. Pract. Theory*, vol. 52, pp. 40–51, Mar. 2015.
- [287] D. Abbas, A. Martínez, and G. Champenois, "Life cycle cost, embodied energy and loss of power supply probability for the optimal design of hybrid power systems," *Math. Comput. Simul.*, vol. 98, pp. 46–62, Apr. 2014.
- [288] U. B. Akuru, I. E. Onukwube, O. I. Okoro, and E. S. Obe, "Towards 100% renewable energy in Nigeria," *Renew. Sustain. Energy Rev.*, vol. 71, pp. 943–953, May 2017.
- [289] J. Cloke, A. Mohr, and E. Brown, "Imagining renewable energy: Towards a social energy systems approach to community renewable energy projects in the global south," *Energy Res. Social Sci.*, vol. 31, pp. 263–272, Sep. 2017.
- [290] R. Kasperowicz, M. Pinczynski, and A. Khabdullin, "Modeling the power of renewable energy sources in the context of classical electricity system transformation," *J. Int. Stud.*, vol. 10, no. 3, pp. 264–272, Oct. 2017.
- [291] S. Lall, "Technological capabilities and industrialization," *World Develop.*, vol. 20, no. 2, pp. 165–186, Feb. 1992.
- [292] R. Cabrera and D. González, "Influences of technological attributes on sourcing of manufacturing technologies in developing countries," *Manag. Res., J. Iberoamerican Acad. Manage.*, vol. 17, no. 4, pp. 359–378, Oct. 2019.



JOSIAH LANGE MUNDA (Member, IEEE) received the M.Sc. degree in electric power supply from Tver State Technical University, in 1991, and the D.Eng. degree in electrical engineering from the University of the Ryukyus, in 2002. He is currently a Professor of electrical engineering, the Head of the Department of Electrical Engineering, and the Assistant Dean of postgraduate studies, research, and innovation with the Tshwane University of Technology, South Africa. He has authored or coauthored more than 180 articles in peer-reviewed journals, book chapters, and international conference proceedings and journals. His main research interests include power system analysis, energy efficiency, and demand-side management and microgrids. He is a Senior Member of the South African Institute of Electrical Engineering.



YSKANDAR HAMAM (Senior Member, IEEE) received the B.E. degree in electrical engineering from American University, Beirut, in 1966, and the M.Sc. and Ph.D. degrees from the University of Manchester Institute of Science and Technology, Manchester, U.K., in 1970 and 1972, respectively. From 1966 to 1968, he was an engineer of projects in Beirut. He was an Adjunct Professor with the Universidade Federal Rio de Janeiro, from 1972 to 1973. He was an Assistant Professor with American University, from 1973 to 1976. He was a Researcher with Union Power Companies, Charleroi, Belgium, from 1977 to 1978. From 1979 to 1991, he was the Head of the Department of Continuing Education, Ecole Supérieure d'Ingénieurs Electrotechnique et Electronique (ESIEE), Noisy-le-Grand, France, where he was the Dean of Faculty, from 1991 to 1996. He was with the Deputy Mayor, Town Hall, St.-Michel, France, in 1995. He has been the Head of the Computer Control Laboratory, Noisy-le-Grand, since 1996. He has coauthored four books and 25 chapters in edited books. He has also authored or coauthored more than 100 articles in peer-reviewed archived journals and more than 240 articles in peer-reviewed conference proceedings. He is currently the Scientific Director of the French South African Institute of Technology (F'SATI), Tshwane University of Technology, South Africa, and an Emeritus Professor with the ESIEE. He was an active member of modeling and simulation societies and was the President of EUROSIM. He has been the Vice President of Francoism, since 1993.



OLUBAYO MOSES BABATUNDE (Student Member, IEEE) received the B.Sc. degree in electrical engineering from the University of Ibadan, Ibadan, Nigeria, in 2009, and the M.Sc. degree in electrical engineering with a major in power systems analysis from the University of Lagos, Akoka, Nigeria, in 2014. He is a registered professional engineer in Nigeria.