

# A Cost Model for the WDM Layer

M. Gunkel<sup>1</sup>, R. Leppla<sup>1</sup>, M. Wade<sup>2</sup>, A. Lord<sup>2</sup>, D. Schupke<sup>3</sup>, G. Lehmann<sup>3</sup>, C. Fürst<sup>4</sup>, S. Bodamer<sup>4</sup>, B. Bollenz<sup>5</sup>, H. Haunstein<sup>5</sup>, H. Nakajima<sup>6</sup>, J. Martensson<sup>7</sup>

1: T-Systems Enterprise Services GmbH, Deutsche-Telekom-Allee 7, D-64295 Darmstadt, Germany

2: BT, Adastral Park, Martlesham Heath, Ipswich IP5 3RE, UK

3: Siemens, Corporate Technology, Otto-Hahn-Ring 6, D-81730 Munich, Germany

4: Ericsson GmbH, Gerberstr. 33, D-71522 Backnang, Germany

5: Lucent Technologies Network Systems GmbH, Thurn-und-Taxis-Str. 10, D-90411 Nuremberg, Germany

6: France Telecom, R&D, 2 avenue Pierre-Marzin, 22307 Lannion Cedex, France

7: Acreo, Electrum 236, SE-164 40 Kista, Sweden

**Abstract:** In this paper a detailed capital expenditure cost model is presented taking various network elements and node architectures at the WDM layer into account. It was developed within the European NOBEL project [1] and aligned by major European network suppliers and operators. The current cost structure of WDM transport equipment is shown in a normalised format. Typical model applications are also discussed by presenting examples. This model can serve as a reference for future techno-economic research into optical transport networks in general.

**Keywords:** Cost model, WDM layer, normalised cost values, cost dependent network design, CapEx

## 1. Introduction

The definition of a consistent WDM cost model comprising relevant network equipment is crucial for all techno-economic studies comparing different network alternatives. However, detailed cost values are hard to derive for many reasons where the most important seem to be the following:

- First of all, actual costs are usually commercially confidential.
- Vendors try to differentiate their product families making it difficult to refer to a typical, commercially available transport system fitting into a neat category.
- Learning curves affect equipment prices year on year. Hence, referencing commercial price data from different years makes a comparison questionable.
- Furthermore, vendors may offer discounts dependent on the operator. Under circumstances, they may even consider going below manufacturing cost to win market share.

Nevertheless, several partners in the European research project NOBEL [1] contributed to and agreed on a normalised cost model for WDM equipment. It was decided that mainly the involved incumbent network operators take the first step since they have direct access to commercial quotes. As a second step the figures were checked by system vendors. Finally, realistic ratios of equipment costs were achieved, although they do not exactly reflect partners' real internal cost data.

The following cost tables have mainly been derived in order to assess the potential benefit of transparent over traditional opaque network concepts. The idea of optical transparency is to reduce network cost by bypassing transit traffic in the optical domain unless regeneration or wavelength translation is necessary. This optical bypass especially leads to a significant reduction in optical-electrical (OE) conversions. Section 2 now gives an overview of the cost modelling concept and the underlying assumptions, together with the consolidated cost tables.

## 2. Modelling Methodology and Cost Tables

For simplicity, it was decided to consider the nowadays prevalent data rate of 10 Gbit/s and a network architecture based on generic current transport systems rather than any vendor specific one. The following cost values refer to capital expenditure (CapEx) only and are normalised to the cost of a 10 Gbit/s transponder suitable for transmission over a reach of 750 km. This normalisation should help to reduce the variability of cost data between different sources, as this partially removes the issue of different vendor discounts offered to customers. If not noted otherwise, all cost values refer to a complete bidirectional network element (NE) including all basic requirements like racks, power supplies and software

The cost model can be divided into three classes. The first class deals with pure transmission equipment, for which three different maximum transmission distances (MTDs) have been defined: 750, 1500 and 3000 km measured by the total spans of the transmission fibre. When passing through a transparent node a reach penalty equivalent to one fibre span of typically 80 km was defined as a practical value. Different MTDs can be obtained by a specific technology, e.g., by a standard or enhanced forward error correction (FEC), power and/or dispersion management or gain equaliser. Reach-dependent building blocks are considered in Table 1:

- all types of OE/OEO conversion devices, i.e. tuneable transponders, coloured line cards and regenerators/wavelength converters
- in-line amplifiers
- dispersion compensating fibre modules

In a second equipment class, Table 2, the capacity dependent building blocks are differentiated by either 40 or 80 wavelength channels:

- WDM terminals
- fixed optical add/drop multiplexers (OADMs) based on patch panels and variable optical attenuators (VOA)
- reconfigurable OADMs (ROADMs) based on wavelength blockers (WBs)
- optical cross-connects (OXC) based on wavelength selective switches (WSSs) in a broadcast and select (B&S) architecture with variable number of fibre ports

While OADMs and OXC are similar in function, the former are designed for nodes with two fibre ports and the latter for nodes with higher numbers of fibre ports. The number of fibre ports is denoted by N in the cost tables.

Beside the multiplexing and demultiplexing cost, all node costs in Table 2 include optical supervisory units, optical power control, etc. However, all node costs are counted without amplification modules, which are members of the last other equipment class in Table 3, including:

- terminal amplifier in a single or double stage configuration
- amplifier dedicated to compensate the insertion losses of transparent nodes
- dynamic gain equalising amplifier, required every fourth amplifier site on a link

- short reach (SR) switch line cards interfacing tributary traffic
- electrical cross-connect (EXC) (potentially grooming at a VC-4 granularity)

The electrical cross-connect is priced linearly per 10 Gbit/s equivalent port while all other blocks are priced for a complete NE. It is worth mentioning that for simplicity all amplification stages of Table 3 are modelled to be MTD-independent.

For traffic on parallel fibres flowing in the same direction it is not required to offer a connection capability in the transparent node. In this case it is possible to further reduce the network cost by removing all concerned WB/WSS-based switch functions. Table 4 shows the cost values for WBs and WSSs on a device level in dependence on the number of input ports. These costs are already integrated in Table 2. It should be mentioned that the cost values of Table 4 relate to a bidirectional device while the costs of Table 2 scale with the number N of input fibres which are unidirectional in nature. Note, the nomenclature of input and output port is derived from the so-called combiner configuration which is the typical WSS application. Together with the basic assumptions for the WDM link design, the following section presents the assumed node architectures under which the above cost table was derived.

**Table 1: Cost model, reach dependent equipment**

Cost per ...	10G Transponder Card	10G Coloured Line Card	10G Regenerator / Wavelength Converter	In-line amplifier	Dispersion compensating fibre per 80 km span
MTD = 750 km	1	0.9	1.4	3	0.9
MTD = 1500 km	1.4	1.3	2	3.8	1
MTD = 3000 km	1.9	1.8	2.7	4.7	1.2

**Table 2: Cost model, capacity dependent equipment, network element level**

Cost per ...	WDM Terminal	OADM (based on WB, 2 fibre ports)	OXC (based on WSS in a B&S architecture, 3 to 5 fibre ports)	OXC (based on WSS in a B&S architecture, 6 to 10 fibre ports)	OADM / OXC (based on patch panel & VOA)
40 channels	4.5	11.8	$5.35 \cdot N + 2$	$5.85 \cdot N + 2$	$5.75 \cdot N + 2$
80 channels	6.7	17.3	$8.05 \cdot N + 2.2$	$8.65 \cdot N + 2.2$	$10.85 \cdot N + 2.2$

**Table 3: Cost model, further equipment**

Cost per ...	Amplifier in terminal, single stage	Amplifier in terminal, double stage	Amplifier in transparent node (per bidirectional fibre pair)	Dynamic Gain Equaliser (DGE), every fourth amplifier site	SR Switch Line Card 10G	EXC switch (per 10G equiv. port)
	2	3	1.25	3	0.25	0.28

**Table 4: Cost model, transparent switch functionality at a device level**

Configuration, number of input ports	Realisation option	Cost for a bidirectional device, 40 channels	Cost for a bidirectional device, 80 channels
1	WB	2.9	3.2
2 to 4	1x4 WSS (5 ports)	3.8	4.2
5 to 9	1x9 WSS (10 ports)	4.8	5.4
10 to 12	1x4 & 1x9 WSS cascaded	8.6	9.6
13 to 17	1x9 & 1x9 WSS cascaded	9.6	10.8

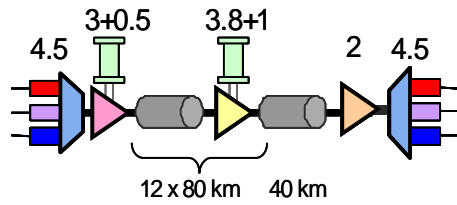

**Figure 1: Normalised cost values for a 1000km link (40ch system); transponders & DGE not explicitly priced.**

### 3. Building Blocks

#### 3.1 Link Architecture

In the opaque case, a link is encapsulated by WDM terminals equipped with a set of transponder cards or coloured line cards. Buried fibre is mainly sufficiently available today and need not be priced. The fibre segments are assumed to form spans with an average length of approximately 80 km. Figure 1 shows a 1000 km link as an example. For dispersion compensation (DC) a generic full in-line pre-compensation scheme is implied. Note that the details of DC are considered to be irrelevant for cost evaluation purposes. From left to right, costs arise for the terminal (40 channel maximum capacity assumed here), the dual-stage booster amplifier and its DC-module pre-compensating for 40 km transmission fibre at the link origin, in-line amplifiers capable for transmission over a reach of above 750 km and a receiver-side single-stage pre-amplifier followed by the receiving terminal. The location of the booster and pre-amplifier is reversed when the backward direction is considered.

**Table 5: Cost report for the 1000 km link**

Equipment type	Unit Cost	Quantity (bidir.)	Total Cost
WDM Terminals	4.5	2	9
Booster Amplifier	3	1	3
In-line Amplifiers	3.8	12	45.6
Preamplifier	2	1	2
DCF Modules <sup>1</sup>	1	12.5	12.5
DGEs <sup>2</sup>	3	3	9
<b>Total Cost</b>			<b>81.1</b>

**Table 6: Cost report for the 720 km link**

Equipment type	Unit Cost	Quantity (bidir.)	Total Cost
WDM Terminals	4.5	2	9
Booster Amplifier	3	1	3
In-line Amplifiers	3	8	24
Preamplifier	2	1	2
DCF Modules <sup>1</sup>	0.9	9	8.1
DGEs <sup>2</sup>	3	2	6
<b>Total Cost</b>			<b>52.1</b>

Including DGEs in every fourth amplifier site on average, the link deployment cost (without transponders) sums up to 81.1 normalised cost units (c.u.). Consequently, one can postulate as a rule of thumb, that the cost of 29 transponder pairs (MTD = 1500 km) is in the same range as the pure transmission equipment cost. Surprisingly, this

<sup>1</sup> DCF modules cost refer to an 80 km fibre span.

<sup>2</sup> DGE quantity per link is calculated as floor(#spans/4), where floor(x) is the largest integer less than or equal to x.

statement still roughly holds if a 720 km link were considered (9 x 80 km, 52.1 c.u. which is equivalent to 26 transponder pairs). The reason can mainly be traced back to the 40% cost premium of the transponder with MTD = 1500 km over the transponder with MTD = 750 km.

#### 3.2 Node Architectures

The node architectures assumed in the cost tables are depicted in Figure 2 to Figure 6. One has to distinguish between an opaque and a transparent node architecture.

An opaque node terminates all incoming wavelengths. Figure 2 illustrates the most common opaque node model employed today. It consists of a time-division multiplexing (TDM) switch fabric (i.e. an EXC), which is capable of switching traffic between any ports. When considering current SDH switches, the switching granularity is normally VC-4 allowing for grooming lower granularity legacy traffic, but may also be STM-16 or higher. Thus switching at the 10 Gbit/s level via such a switch may be wasteful on ports. In next-generation OTN switches, the granularity is upgraded to ODU1 (2.5 Gbit/s).

The switch interfaces (grey) are line cards with optical interfaces at 1310nm for add/dropping traffic to client equipment and connecting to transponders at the WDM terminals. The transponders themselves have switch-facing optical interfaces at 1310nm and line-facing optical interfaces at an ITU grid wavelength. Although the number of OE conversions is large, high network utilisation can be achieved if the opaque node contains grooming capability.

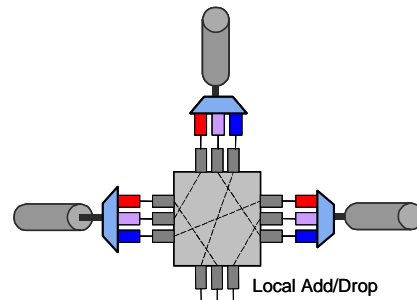
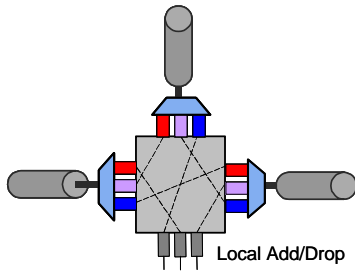

**Figure 2: Opaque node with switch interfaces and potentially intermediate electrical grooming**

Figure 3 shows a variant of an opaque node architecture. It differs from the previous model only in that the transponders and switch line cards are replaced by coloured line cards at the switch with ITU grid wavelengths towards the line side. Although this involves fewer components and is thus theoretically cheaper than the traditional node model from a CapEx point-of-view, incumbent operators are currently reluctant to employ such a solution. This normally involves using a single supplier for the switching and transmission equipment, which would require a potential shift in operator strategy. The integration of switching and transmission layer functionalities in this node architecture leads also to modifications in the network management implementation.

When moving towards transparent node architectures, the optical bypass can in principle be realised by the usage of optical patch panels (OPP, not depicted here). Whilst this is very cost-efficient at low traffic volumes, this approach is not very flexible, especially when traffic increases or has to be rerouted. Furthermore, additional costs for remotely controlled variable optical attenuators (VOA) are incurred in order to cope with the power fluctuations in each

channel. In total, this solution turns out to be less cost-efficient than a WSS based node architecture presented below.



**Figure 3: Opaque node with coloured line cards and potentially intermediate electrical grooming**

Figure 4 illustrates a transparent node model based on a monolithic, optically transparent switch fabric. Before entering and after exiting the switch fabric, the complete WDM comb is demultiplexed and multiplexed again, respectively. That is why this architecture is denoted as a demux-switch-mux configuration. The traffic is switched at the wavelength level, regardless of the traffic granularity. The only transponders present in this architecture are for add/dropping traffic to client equipment.

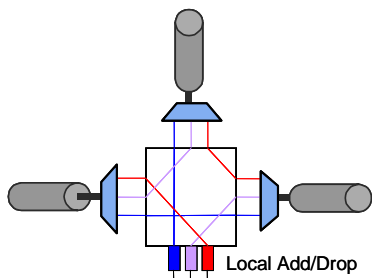
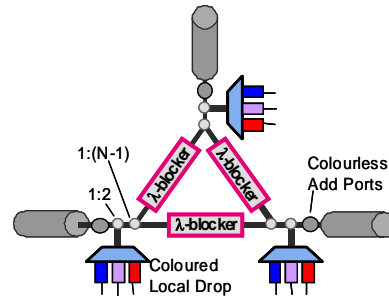

**Figure 4: Transparent node based on a monolithic switch fabric, e.g. MEMS**

The demux-switch-mux configuration typically implemented by arrayed waveguide gratings (AWGs) and a larger switch based on a micro electro-mechanical system (MEMS) has a series of drawbacks. Architectures relying on WB and/or WSS are considered to be much more promising. A WB will be a key component enabling optically transparent networks both from an investment and an operational point of view. While this device serves to block wavelengths from crossing the node that are dropped locally, it also integrates a wavelength power equalisation capability for channels which traverse the node. A single WB device consequently adjusts the output power of each input channel, either by equalising the power to ensure a certain power level or by strongly reducing the power in order to prevent the channel from passing this device.

In Figure 5, a schematic diagram of a transparent switch node based on WB is shown. The WB is drawn as a bidirectional element. With a passive 1:2 splitter the incoming WDM signal is duplicated for local drop. Coloured drop ports come along with a relatively low cost, though they provide restricted flexibility for remote reconfiguration. Behind the splitter, a 1:(N-1) coupler broadcasts the complete spectrum to a WB, one in each branch. There it is decided whether a selected channel is suppressed or passed-through (B&S architecture). Finally, colourless add ports realised by a passive star coupler

provide the cheapest flexible solution for local add functionality.



**Figure 5: Transparent OXC based on WBs**

When compared to a WSS, a WB has a medium advantageous cost scalability because the number of WB devices scales to first order according to a quadratic law with the number of fibre input ports. The WSS is similar to the WB. The main difference is that it provides multiple fibre ports at the input side. Each port potentially carries a complete WDM input comb. The device is used to select any single wavelength from one input port to pass to the common output port and simultaneously to equalise the power levels. In principle, the device can be applied in the opposite direction, too.

Figure 6 illustrates a WSS-based OXC in the typical combiner configuration. Similar to the WB-based OXC, coloured drop and colourless add ports are assumed. In contrast to the WB-based OXC, the complete incoming WDM spectra from all directions enter the same WSS. Inside this device it is decided which wavelength from which fibre port is allowed to pass through. From a cost scaling point of view, a WSS overcomes the WB's scalability drawback since it scales linearly, i.e. only one device is needed per output fibre. Therefore, usually a WB is only beneficial in ROADMs with two fibre ports, while a WSS is preferable for more fibre ports.

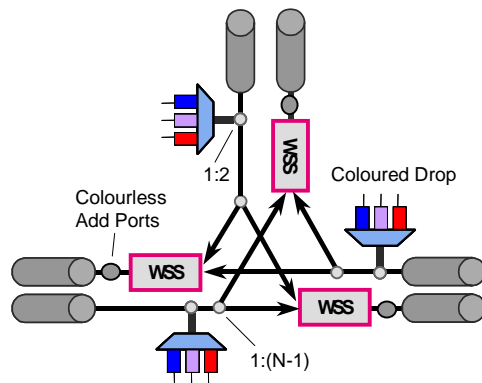

**Figure 6: Transparent OXC based on multi-port WSSs in a combiner configuration (Note: Unidirectional devices are depicted here.)**

Several further flavours of transparent or hybrid (transparent-opaque) node architectures are conceivable. As schematically shown in Figure 7, one promising concept consists of an all-optical cross-connect (OXC) directly interfacing the line system and an EXC in combination. In the simplest case the EXC is only used for add-drop traffic. However, it has been shown [2] that it is beneficial to use the EXC also for intermediate grooming to increase wavelength utilisation.

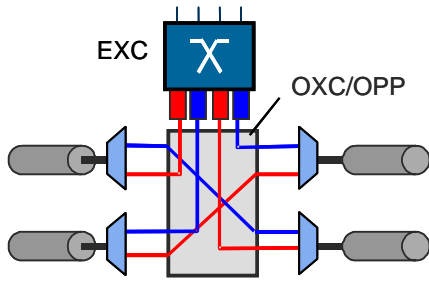

Figure 7: Hybrid transparent node architecture integrating an all-optical cross-connect and an EXC

#### 4. Cost Modelling Examples

The simplest cost comparison of opacity versus transparency consists in the substitution of a bi-connected traditional opaque node by a transparent ROADM which is depicted in Figure 8 and Figure 9.

As stated above, all normalised costs for the transparent node equipment disregard the costs for amplification. To compensate for the insertion losses, a special amplifier type is defined in Table 3. In order to keep the cost scaling consistent, each input/output fibre pair is treated as if it were equipped with this amplifier of an averaged cost of 1.25 c.u. Practically, however, this stage compensates for both the span and node's insertion losses. It is derived as a mix of a single and double amplifier stage (2.5 c.u.) and only artificially split on all bidirectional fibre ports.

For cost comparison a configuration is assumed with a channel load per link of 20 wavelengths together with a used add/drop capacity of 8 wavelengths at the intermediate node. In the opaque case there is a total cost of 184.5 c.u. while a transparent architecture costs 153.7 c.u., see Table 7 and Table 8 for a detailed cost calculation.

This is a cost reduction with respect to the opaque reference of 16.7% in total.

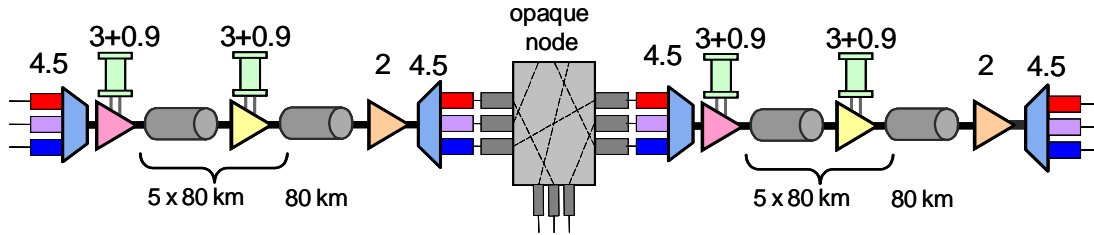

Figure 8: Two 480 km links with an intermediate opaque node; transponders & DGE not priced.

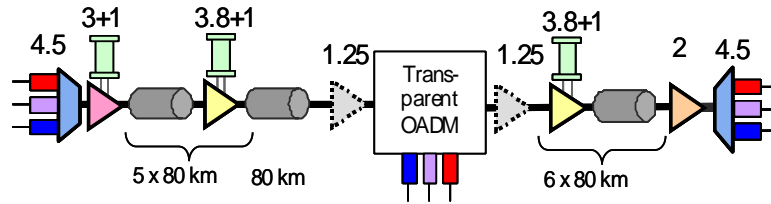

Figure 9: Two 480 km links with an intermediate transparent ROADM; transponders & DGE not priced.

Table 7: Cost report for the opaque case in Figure 8

Equipment type	Unit Cost	Quantity (bidir.)	Total Cost
Transponders	1	2*40	80
WDM Terminals	4.5	2*2	18
Booster Amplifiers	3	2	6
Inline Amplifiers	3	2*5	30
Preamplifiers	2	2	4
DCF Modules <sup>1</sup>	0.9	12	10.8
DGEs <sup>2</sup>	3	2	6
SR Line Cards	0.25	20+20+8+8	14
EXC	0.28	20+20+8+8	15.68
<b>Total Cost</b>			<b>184.48</b>

Table 8: Cost report for the transparent case in Figure 9

Equipment type	Unit Cost	Quantity	Total Cost
Transponders <sup>3</sup> , 750 km	1	2*2*8	32
Transponders <sup>3</sup> , 1500 km	1.4	2*12	33.6
WDM Terminals	4.5	2	9
Booster Amplifiers	3	1	3
Inline Amplifiers	3.8	11	41.8
Transp. Node Amp.	1.25	2	2.5
Preamplifiers	2	1	2
DCF Modules <sup>1</sup>	1	12	12
DGEs <sup>2</sup>	3	2	6
ROADM	11.8	1	11.8
<b>Total Cost</b>			<b>153.7</b>

<sup>3</sup>As a consequence of different transmission lengths, two different transponder types have to be selected.

## 5. Discussion

While this transparency-related cost reduction is comparably small, it generally increases with the traffic volume in a transparent network. Furthermore, in the example above only one intermediate opaque node is substituted by a transparent one. It can be simply shown that for the same link with three intermediate nodes substituted, the total cost savings amount to about 30% mainly due to reduced transponder expenditures.

In various studies conducted by several NOBEL partners [2, 3], cost savings of a transparent solution over an opaque network design of up to 50% could be achieved mainly depending on traffic volume and protection / restoration requirements. Since transponders make up the largest contribution to the overall capital expenditure, their elimination under future high traffic scenarios achieves the largest cost reduction. However, optical transparency still allows substantial cost savings even in the case of considerable transponder cost erosion [3]. The selection of the most suitable transparent node architecture depends on the detailed network scenario.

## 6. Summary and Outlook

A consistent cost model for state-of-the-art WDM equipment has been presented. The underlying assumptions have been discussed and the application of the model has been shown through examples. It could be shown that transparent network architectures offer significant cost saving potential.

In the future, it is intended to adapt the existing cost tables according to market developments at the WDM layer and to fine-tune the cost values when necessary. Furthermore, the cost model shall be expanded with higher layer equipment (Ethernet and IP layer) offering the ability to investigate multilayer cost analysis on a detailed and consistent basis.

## 7. Acknowledgement

The work reported in this paper has been supported by the European Commission in the context of the IST project NOBEL. The responsibility for the content of this paper is with the authors.

The authors would like to thank all NOBEL partners from work package 5 who have contributed to this cost model.

## 8. References

- [1] IST project NOBEL, <http://www.ist-nobel.org>.
- [2] S. Bodamer, C. Fürst, M. Gunkel: "Benefit of transparent optical networks in the presence of transponder price erosion." ITG-Fachtagung Photonische Netze, 2006.
- [3] IST project NOBEL, work package 5, Deliverable 28, Chapter 2.4, January 2006.