



AALBORG UNIVERSITY
DENMARK

Aalborg Universitet

A Discussion about Upgrading the Quick Script Platform to Create Natural Language based IoT Systems

Khanna, Anirudh; Das, Bhagwan; Pandey, Bishwajeet; Hussain, Dil muhammed Akbar; Jain, Vishal

Published in:
Indian Journal of Science and Technology

DOI (link to publication from Publisher):
[10.17485/ijst/2016/v9i46/106917](https://doi.org/10.17485/ijst/2016/v9i46/106917)

Creative Commons License
CC BY 3.0

Publication date:
2016

Document Version
Publisher's PDF, also known as Version of record

[Link to publication from Aalborg University](#)

Citation for published version (APA):
Khanna, A., Das, B., Pandey, B., Hussain, D. M. A., & Jain, V. (2016). A Discussion about Upgrading the Quick Script Platform to Create Natural Language based IoT Systems. *Indian Journal of Science and Technology*, 9(46). <https://doi.org/10.17485/ijst/2016/v9i46/106917>

General rights

Copyright and moral rights for the publications made accessible in the public portal are retained by the authors and/or other copyright owners and it is a condition of accessing publications that users recognise and abide by the legal requirements associated with these rights.

- Users may download and print one copy of any publication from the public portal for the purpose of private study or research.
- You may not further distribute the material or use it for any profit-making activity or commercial gain
- You may freely distribute the URL identifying the publication in the public portal -

Take down policy

If you believe that this document breaches copyright please contact us at vbn@aub.aau.dk providing details, and we will remove access to the work immediately and investigate your claim.

A Discussion about Upgrading the Quick Script Platform to Create Natural Language based IoT Systems

Anirudh Khanna^{1*}, Bhagwan Das², Bishwajeet Pandey³, DMA Hussain⁴ and Vishal Jain⁵

¹Chitkara University, Kalu Jhanda - 174103, Himachal Pradesh, India; akhanna.cse@gmail.com

²University Tun Hussein Onn Malaysia, Malaysia; engr.bhagwandas@hotmail.com

³Gyancity Research Lab, India; gyancity@gyancity.com

⁴Aalborg University Denmark; akh@et.aau.dk

⁵Bharati Vidyapeeth's Institute of Computer Applications and Management (BVICAM), New Delhi – 110063, India; vishaljain83@gmail.com

Abstract

Objectives: With the advent of AI and IoT, the idea of incorporating smart things/appliances in our day to day life is converting into a reality. The paper discusses the possibilities and potential of designing IoT systems which can be controlled via natural language, with help of Quick Script as a development platform. **Methods/Statistical Analysis:** Quick Script (or QS) is an open-source, easy to learn tool made by our team of student developers for programming virtual conversational entities. This paper focuses on a discussion about how some improvements can be made in the underlying implementation of QS and the resulting uncomplicated and simple platform which can be used to create natural language based IoT systems. It explores the architecture/design pattern required for creating such systems. **Findings:** This exploration reveals how the idea of turning a simple NLP tool to handling IoT systems can be implemented, and where all the necessary changes/additions are to be made. The benefits of this will include sharing the power of controlling and even programming (up to some extent) to the user end. As well as providing a simple intermediary to make communication between man and his machines a little more natural. **Application/Improvements:** It has always been a fantasy in movies to have appliances and gadgets work according to our speech inputs in real time. We humans have always tried to take complete advantage of technologies for living better and working more productively. The idea behind this paper drives for the same cause. Applications of any natural language based service can be endless—ranging from home to industry. With the speech based interaction, this will even help the physically disabled people.

Keywords: Artificial Intelligence, Internet of Things, Natural Language Processing, Quick Script, Smart Devices

1. Introduction

Internet of Things (IoT) is a system of interrelated computing devices and electronic appliances that are identified uniquely on a network and have the ability to transfer and receive data over the network and perform actions according to given data smartly, without requiring constant human supervision. It is to be noted that once developed and presented for use, working with IoT systems does not remain that complex as it sounds in the

above definition. In fact, IoT encourages more efficient ways of interaction between humans and various devices. It has drastically changed the ways in which interaction happens between humans-and-machines as well as machines-and-machines and pushed the concept of smart living to a new level. IoT, together with the other emerging Internet developments will act as the backbone of the digital economy and society¹. That's why IoT is also used for active contour modeling in object tracking².

*Author for correspondence

There is much research going on to find a way to apply IOT in network security³ and computer memory⁴. Internet of Things describes how ideas and thoughts of human beings could create a technological or electrical connection between the things itself and people which could benefit them and can create ease in their life⁵.

In the earlier days, this interaction was mostly localized – it was not possible to control appliances over a network; use of switches and similar interfaces was the only way to turn machines ON/OFF or to control them. Then came the concept of smart devices and Internet of Things enabled homes – where every appliance is given an IP address and with the power of Internet, we are able to control our devices from anywhere in the world with any device that has a connection. But what now – what about the next level of human and machine interaction? We foresee that it is the interaction in natural language which will take hold in the future. And developments are already happening in this field; take personal assistants like Siri and Cortana for example. Controlling cell phones just by talking to them used to be a distant dream two decades back. If it is possible to control a smart phone with natural language, why not control every device, every appliance in our homes and offices in such a way? By combining the concepts of Artificial Intelligence and Internet of Things, it is definitely possible to convert today’s “smart devices” to “Intelligent Devices”.

Chatbots are a prolific example of Natural Language Processing (NLP) system. There are some languages and development tools which are used to create chatbots, and they can be employed with IoT systems also. The student team from Chitkara University developed QuickScript as one such platform for designing programs to interact with the computer in natural language. It is an open source language which focuses on simplicity and coherence while programming virtual conversational entities. It can be downloaded from its website⁶ or GitHub repository⁷. Figure 1 shows the Quick Script interface.

The internal implementation of QuickScript is in C language, and also there is ongoing development of it better versions, which will positively be available from time to time. Its syntax is minimalistic and simple and can be easily modified (upgraded) according to the user needs. These are the reasons why QuickScript can become a perfect tool to add natural language processing to IoT systems and smart appliances.



Figure 1. QuickScript Interface (in C implementation).

2. Quick Script Syntax

Every Quick Script program consists of lines of text called “entries”. Each entry can be (generally) seen as a single unit of knowledge in the NLP system being designed. It is often mentioned that the power of Quick Script is its simplicity, and to justify that, some light must be shed on the structure of Quick Script syntax. Each statement (entry) can be seen as two parts – one part (called “prefix”) which tells the purpose of that very statement, i.e. how it acts in the program and the second part (called “content”) consists of the actual content (knowledge) which is to be stored in the knowledge base.

Entries can be classified in various types based on their prefix. They can be patterns (that are matched with a user input), responses (text the chatbot will reply when a pattern is found), comments, SRAI statements, learn commands etc. Simplest set of entries can be a group of pattern-response pairs, which surely can support a crude form of conversation, but is practically not sufficient for a perfect chatbot. Still, it is enough to give a fair idea about programming in QuickScript:

```
>> HELLO
## Hi! Good to see you.
>> WHO ARE YOU
## I am a chatbot written in QS.
>> ARE YOU FEMALE
## I am a male chatbot.
```

Figure 2 shows the resulting conversation based on the above given code. Figure 3 briefly displays some types of QuickScript entries with examples.

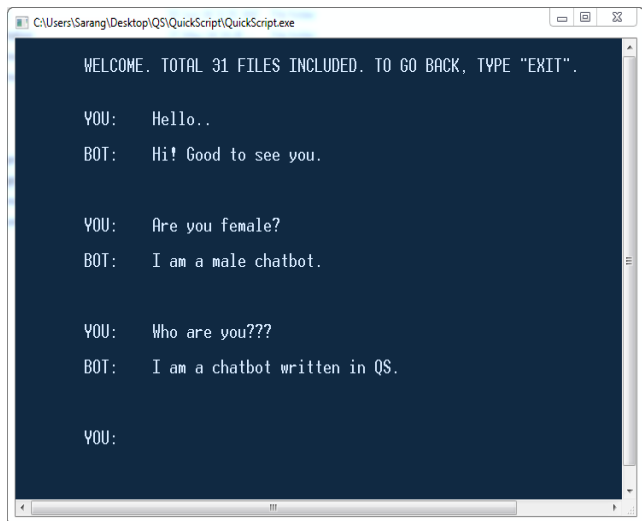

Figure 2. Screenshot of conversation in the chatting interface.

Type	Prefix	Content
pattern	>>	HELLO
response	##	Hi! Good to see you.
pattern	>>	HEY THERE
SRAI	==	HELLO
comment	//	This is a comment

Figure 3. Various types of entries with examples (Refer to QuickScript documentation file for details⁸).

3. Quick Script to be used with IoT Enabled Systems

Due to the simplicity in syntax and uncomplicated implementation, Quick Script can be readily upgraded with newer syntax of entries that can be used in programming NLP for smart appliances. As shown in Figure 4, the NLP created in Quick Script can be interfaced with an existing NLP system. Also, with some necessary additions in the underlying programming, Quick Script can be directly employed to control the functions of smart devices.

Now the question arises – what can be the possible up gradations implemented in QuickScript to make it suitable for programming any such thing in real life? While a number of new kinds of entries must be added to make it work satisfactorily at an industrial level, just for a glimpse of how it will look like, we can consider adding simple {ON} and {OFF} queries which will be implemented as in code given below:

```

>> TURN ON THE FAN PLEASE
{ON} <fan_id>
>> TURN OFF THE FAN PLEASE
{OFF} <fan_id>
>> WILL YOU SWITCH OFF THE LED
{OFF} <led_light_id>
    
```

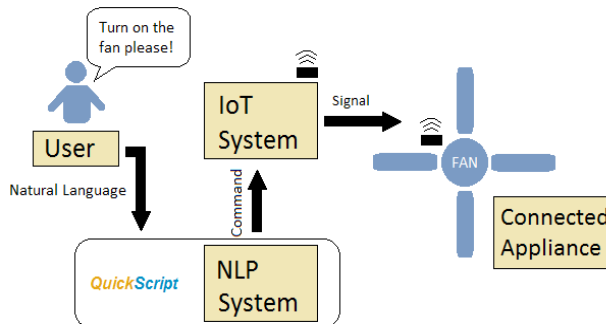

Figure 4. Conceptual diagram for a natural language based smart system.

Here, the simplicity of the syntax is the most important thing to be noted. All the underlying programming of turning an appliance ON or OFF is completely hidden from the designer of IoT system – supporting abstraction! In fact, this will enable a wider number of people to easily design some of their own IoT appliances themselves. Moreover, with the new External Learning feature of Quick Script (see complete Quick Script documentation⁸ for details), the end user can make modifications to existing NLP database and also add some of his own – he just has to learn a few, simple syntax and commands of Quick Script.

4. Advantages

There are various advantages in the above described ideas of utilizing NLP with Internet of Things. In fact, a 2010 study on IoT published by the IEEE Computer Society⁹ proposes “Smart-Object Typology”, where the features of such a system are divided into three parts - Awareness (ability to understand real world events and human activities), Representation (the programming model — in particular, programming abstractions) and Interaction (ability of interaction with the user). It is a proudly stated fact that QuickScript has the potential to enhance all of these features in an IoT system.

Figure 5 shows an example where user may himself program the software to turn appliances ON and OFF, with the help of External Learning feature.

```

C:\Users\Sarang\Desktop\QS\QuickScript\QuickScript.exe
WELCOME. TOTAL 31 FILES INCLUDED. TO GO BACK, TYPE "EXIT".

YOU: Please turn on the lights
BOT: I always tend to try my best.

YOU: {LEARN} {ON} light_0i4568
Okay!
I will try to do " {ON} LIGHT_0I4568"
when someone says "PLEASE TURN ON THE LIGHTS"
from the next time I'm loaded.

YOU:
  
```

Figure 5. End users may be able to design/supervise a natural language IoT of their own.

5. Challenges

While discussion about such an implementation is quite easy, real development poses some challenges:

- **Portability:** Current version of QuickScript is not portable enough to suit every machine. Working with Internet of Things requires portability to a great extent. Although, QuickScript usage will be probably fit when operated from a computer system, but not on many portable devices yet.
- **Security:** IoT brings every appliance to the Internet and that means a great threat to security and privacy. Necessary security measures are not yet implemented in QuickScript, because it was never intended for such a purpose.

6. Acknowledgements

Sincere acknowledgement and thanks to the mentors who encouraged the development of the ideas

that were discussed in this paper. Also, gratitude to the whole QuickScript team, which joined the open source QuickScript project and with time, shaped it to betterment.

7. References

1. Vermesan O, Friess P, Guillemin P, Gusmeroli S, Sundmaecker H, Bassi A, Jubert IS, Mazura M, Harrison M, Eisenhauer M, Doody P. Internet of things strategic research roadmap. *Internet of Things: Global Technological and Societal Trends*. 2011; 1:9-52.
2. Musavi SH, Chowdhry BS, Kumar T, Pandey B, Kumar W. IoTs enable active contour modeling based energy efficient and thermal aware object tracking on FPGA. *Wireless Personal Communications*. 2015 Nov; 85(2):529-43.
3. Singh D, Garg K, Singh R, Pandey B, Kalia K, Noori H. Thermal aware internet of things enable energy efficient encoder design for security on FPGA. *International Journal of Security and its Application*. 2015 Jun; 9(6):271-8.
4. Verma G, Moudgil A, Garg K, Pandey B. Thermal and power aware Internet of Things enable RAM design on FPGA. *IEEE 2nd International Conference on Computing for Sustainable Global Development (INDIACom)*; 2015 Mar 11. p. 1537-40.
5. Bhatia EK, Ohri S, Kaur G, Dhankar M, Dabas S. Future perspective and current aspects of internet of things enable design. *International Journal of Software Engineering and its Applications*. 2015; 9(8):127-32.
6. QuickScript - Easy to learn language for Artificial Intelligence. Available from: <http://anirudhkhanna.github.io/QuickScript>
7. GitHub: anirudhkhanna - QuickScript. Available from: <https://github.com/anirudhkhanna/QuickScript>
8. GitHub: QuickScript/documentation. Available from: <https://github.com/anirudhkhanna/QuickScript/tree/master/documentation>.
9. Kortuem G, Kawsar F, Sundramoorthy V, Fitton D. Smart objects as building blocks for the internet of things. *IEEE Internet Computing*. 2010 Jan; 14(1):44-51.