

**GT2005-68456**

## **A FURTHER STEP TOWARDS A GRAZ CYCLE POWER PLANT FOR CO<sub>2</sub> CAPTURE**

**W. Sanz, H. Jericha, F. Luckel, E. Göttlich, F. Heitmeir**

Institute for Thermal Turbomachinery and Machine Dynamics  
Graz University of Technology, Graz, Austria  
wolfgang.sanz@tugraz.at

### **ABSTRACT**

Introduction of closed cycle gas turbines with their capability of retaining combustion generated CO<sub>2</sub> can offer a valuable contribution to the Kyoto goal and to future power generation. Therefore research and development work at Graz University of Technology since the nineties has led to the Graz Cycle, a zero emission power cycle of highest efficiency. It burns fossil fuels with pure oxygen which enables the cost-effective separation of the combustion CO<sub>2</sub> by condensation. The efforts for the oxygen supply in an air separation plant are partly compensated by cycle efficiencies far higher than for modern combined cycle plants.

At the ASME IGTI conference 2004 in Vienna a high steam content S-Graz Cycle power plant was presented showing efficiencies for syngas firing up to 70 % and a net efficiency of 57 % considering oxygen supply and CO<sub>2</sub> compression. A first economic analysis gave CO<sub>2</sub> mitigation costs of about 10 \$/ton CO<sub>2</sub> avoided. These favourable data induced the Norwegian oil and gas company Statoil ASA to order a techno-economic evaluation study of the Graz Cycle.

In order to allow a benchmarking of the Graz Cycle and a comparison with other CO<sub>2</sub> capture concepts, the assumptions of component efficiency and losses are modified to values agreed with Statoil. In this work the new assumptions made and the resulting power cycle for natural gas firing, which is the most likely fuel of a first demonstration plant, are presented. Further modifications of the cycle scheme are discussed and their potential is analyzed. Finally, an economic analysis of the Graz Cycle power plant is performed showing low CO<sub>2</sub> mitigation costs in the range of 20 \$/ton CO<sub>2</sub> avoided, but also the strong dependence of the economics on the investment costs.

### **INTRODUCTION**

In the last hundred years the concentration of some greenhouse gases in the atmosphere has markedly increased. There is a wide consensus in the scientific community that this seems to influence the Earth surface temperature and thus the world climate.

Therefore, in 1997 the Kyoto conference has defined the goal of global greenhouse gas emission reduction of about 5 % in the next years compared to the 1990 emission level. CO<sub>2</sub> is the main greenhouse gas due to the very high overall amount emitted by human activities. And about one third of the overall human CO<sub>2</sub> emissions are produced by the power generation sector. In the EU there is a strong pressure on utilities and industry to reduce the CO<sub>2</sub> emissions by power generation. In 2003 the European Parliament passed a directive on emission trading. In 2005 emission allowances are assigned to about 10 000 companies in 25 countries within the EU which cover about 46 % of the overall EU CO<sub>2</sub> emissions. Companies which do not need their full amount can sell it to companies which need more than assigned. As emission allowances become scarce they will have an increasing value, estimates vary between 10 and 20 €/ton CO<sub>2</sub> (12 and 25 \$/ton CO<sub>2</sub>) by 2010 and even more by 2015 [1].

So there is a strong driving force to develop commercial solutions for the capture of CO<sub>2</sub> from power plants. The main technologies are [2]:

- post combustion CO<sub>2</sub> capture, e.g. by washing of exhaust gases using amines
- pre-combustion decarbonization of fossil fuels to produce pure hydrogen
- chemical looping combustion
- oxy-fuel cycles with internal combustion of fossil fuels with pure oxygen

The European Commission is supporting the search for CO<sub>2</sub> capture technologies in power plants under the 6<sup>th</sup> Framework Programme. Five projects with the priorities post-combustion CO<sub>2</sub> capture, pre-combustion CO<sub>2</sub> capture, geological storage of CO<sub>2</sub> and chemical/mineral sequestration of CO<sub>2</sub> have recently started [3]. Within the project ENCAP (Enhanced Capture of CO<sub>2</sub>) optional concepts of CO<sub>2</sub> capture including oxy-fuel cycles are modelled and screened which shall result in the selection of at least one candidate technology concept.

The authors believe that oxy-fuel cycles are a very promising technology and that their Graz Cycle can be the most economic solution for CO<sub>2</sub> capture from fossil power generation once the development of the new turbomachinery components needed are done. Oxygen needed in a large amount for this kind of cycles can be generated by air separation plants which are in use worldwide with great outputs in steel making industry and even in enhanced oil recovery (EOR). The largest air separation plant already in operation for some years in the Gulf of Mexico produces nitrogen for the injection in the gas dome of a large oil field off-shore [4]. The equivalent amount of this oxygen could feed a Graz Cycle plant of 1300 MW.

The basic principle of the so-called Graz Cycle has been developed by H. Jericha in 1985 [5]. Improvements and further developments since then were presented at many conferences [6-12]. Any fossil fuel gas (preferable with low nitrogen content) is proposed to be combusted with oxygen so that mainly only the two combustion products CO<sub>2</sub> and H<sub>2</sub>O are generated. The cycle medium of CO<sub>2</sub> and H<sub>2</sub>O allows an easy and cost-effective CO<sub>2</sub> separation by condensation. Furthermore, the oxygen combustion enables power cycles which are far more efficient than current air-based cycles, thus largely compensating the additional efforts for oxygen production.

At the ASME IGTI conference 2004 in Vienna a Graz Cycle power plant ( High Steam Content Graz Cycle, S-Graz Cycle) was presented with a cycle efficiency of nearly 70 % based on syngas firing [12]. The net efficiency including the efforts of oxygen supply and compression of captured CO<sub>2</sub> for liquefaction was 57.7 %. The general layout of the components for a 100 MW prototype plant showed the feasibility of all components. A concluding economic analysis of the S-Graz Cycle power plant was performed showing very low CO<sub>2</sub> mitigation costs in the range of 10 \$/ton CO<sub>2</sub> avoided.

These very promising data aroused interest in several institutions in Europe, among them the Norwegian oil and gas company Statoil ASA. Statoil initiated a cooperation in order to conduct a techno-economic evaluation study together with a major gas turbine manufacturer. Statoil's objective is to compare the S-Graz Cycle with other efficient CO<sub>2</sub> capture technologies. Based on the results of this evaluation study, a decision will be made if Statoil shall do further work on the S-Graz Cycle.

In preparation for this study the S-Graz Cycle was re-evaluated and optimised with assumptions on component losses and efficiencies Statoil and Graz University of Technology

agreed on. In this work the results of the new thermodynamic evaluation of the S-Graz Cycle concept is presented. Further possible modifications of the cycle scheme are discussed and their potentials are analyzed. A final economic analysis of the Graz Cycle power plant gives the economics of the Graz Cycle under the new premises.

In this work the nomination "Graz Cycle" means "S-Graz Cycle", which is the more efficient variant and will be prosecuted in the future.

## CYCLE CONFIGURATION AND THERMODYNAMIC LAYOUT

All thermodynamic simulations were performed using the commercial software IPSEpro by SIMTECH Simulation Technology [13]. This software allows to implement user-defined fluid properties to simulate the real gas properties of the cycle medium. The physical properties of water and steam are calculated using the IAPWS\_IF97 formulations [14], CO<sub>2</sub> is also modeled as real gas based on correlation of Siewers [15]. Furthermore, a turbine module was developed for the calculation of cooled turbine stages. A simple stage-by-stage approach similar to [16] is assumed which allows to calculate the amount of cooling steam needed per stage. Within the module half of the cooling mass flow is mixed to the main flow at inlet, thus contributing to the stage expansion work. The rest is added at turbine exit. Details of the model are found in [17].

The Graz Cycle is suited for all kinds of fossil fuels. Best results regarding net cycle efficiency and mitigation costs can be obtained for syngas firing from coal gasification, if the syngas production effort is not considered in the thermodynamic balance (but only in the economic balance by elevated fuel costs). The higher net cycle efficiency is due to the fact that the lower oxygen demand of syngas per heat input reduces the effort of oxygen supply considerably. And finally, the higher carbon content results in more favorable mitigation costs per ton CO<sub>2</sub> avoided. But in this work thermodynamic data presented are for a cycle fired with natural gas, because it is the most likely fuel to be used in a first demonstration plant. The composition of the natural gas in mole fractions is: 89 % CH<sub>4</sub>, 8.11 % C<sub>2</sub>H<sub>6</sub>, 2 % CO<sub>2</sub>, 0.89 % N<sub>2</sub>. The lower heating value is 46465 kJ/kg.

The modified component efficiencies and losses agreed with Statoil are shown in Table 1. The assumptions used for the ASME 2004 work [12] are compared with the actual assumptions. Following assumptions need further explanation: 1) The HTT isentropic efficiency of 90.3 % includes the cooling losses and is based on a polytropic efficiency of 85.5 %. 2) The demand of cooling steam is calculated as described above. The increased demand results from a larger number of stages to be cooled. 3) The CO<sub>2</sub> compression from atmosphere to 100 bar is considered in the power balance with a value of 350 kJ/kg CO<sub>2</sub>. This value also includes the compression of the remaining steam at 1 bar (6 % of total mass flow). For the simulation of the cycle variant utilizing the heat of the CO<sub>2</sub> compression intercoolers (see chapter "Modifications of cycle configuration") a compressor isentropic efficiency of 75 % is

**Table 1:** Comparison of applied component efficiencies and losses between ASME 2004 publication and actual work

	Assumptions ASME 04	New Assumptions
Fuel	methane	natural gas
Combustion pressure	40 bar, no pressure loss	40 bar, 4 % pressure loss
Combustor heat loss $\zeta_C$	0 %	0.25 %
Combustion temperature	1400 °C	1400 °C
Oxygen excess (% of stoichiometric mass flow)	0 %	3 %
Turbine efficiency	HTT: 92 % HPT: 90 % LPT: 92 %	HTT: 90.3 % HPT: 90 % LPT: 88 %
Compressor efficiency	88 %	C1+C2: 88 % C3+C4: 78 % CO <sub>2</sub> (1 to 100 bar): 75 %
Pump efficiency	98 %	70 %
Cooling steam mass flow	11.7 %	13.7 %
Heat exchanger pressure loss	0 %	3 %
HRSG pressure loss: cold side	5 bar	3 % per heat exchanger + 5 bar HPT pipe
HRSG pressure loss: hot side	0	4 kPa
HRSG minimum temperature difference ECO/SH	ECO: 5 K SH: 8.4 K	ECO: 5 K SH: 25 K
Condenser exit temperature	19.7 °C	18 °C
Condenser pressure	0.06 bar	0.041 bar
Fuel temperature after preheat	523 °C	150 °C
Oxygen temperature at compressor outlet	250 °C	150 °C
Mechanical efficiency $\eta_m$	99 % per turbomachinery	99.6 % of net power
Generator efficiency $\eta_{gen}$	98.5 %	98.5 %
Transformer efficiency $\eta_{tr}$	100 %	99.65 %
Auxiliary losses $P_{aux}$	-	0.35 % of heat input
Oxygen production	0.25 kWh/kg = 900 kJ/kg	0.25 kWh/kg = 900 kJ/kg
Oxygen compression	1-40 bar: 455 kJ/kg	2.38 – 42 bar: 325 kJ/kg
CO <sub>2</sub> compression 1 to 100 bar	245 kJ/kg	350 kJ/kg

assumed. 4) Whereas most new values imply higher losses, the mechanical efficiency is higher and applied more favorably on the net shaft power (see Eq. (1)). 5) For the oxygen supplied by the air separation unit (ASU) a delivery pressure of 2.38 bar is assumed, so that the oxygen compression work is reduced.

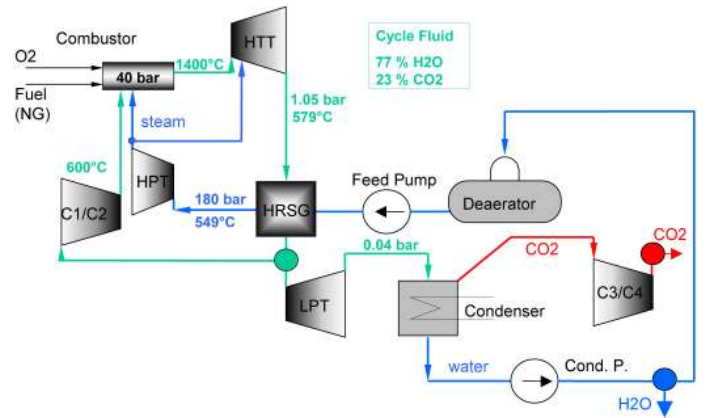

**Fig. 1:** Principle flow scheme of Graz Cycle power plant

Figure 1 shows the principle flow scheme of the S-Graz Cycle as published in [12] with the main components and main cycle data according to the new layout.

Basically the Graz Cycle consists of a high temperature Brayton cycle (compressors C1 and C2, combustion chamber and High Temperature Turbine HTT) and a low temperature Rankine cycle (Low Pressure Turbine LPT, condenser, Heat Recovery Steam Generator HRSG and High Pressure Turbine HPT). The fuel together with the nearly stoichiometric mass flow of oxygen is fed to the combustion chamber, which is operated at a pressure of 40 bar. Steam as well as a CO<sub>2</sub>/ H<sub>2</sub>O mixture is supplied to cool the burners and the liner.

A mixture of about 74 % steam, 25.3 % CO<sub>2</sub>, 0.5 % O<sub>2</sub> and 0.2 % N<sub>2</sub> (mass fractions) leaves the combustion chamber at a mean temperature of 1400°C. The fluid is expanded to a pressure of 1.053 bar and 579 °C in the HTT. Cooling is performed with steam coming from the HPT (13.7 % of the HTT inlet mass flow), increasing the steam content to 77 % at the HTT exit. It is quite clear that a further expansion down to condenser pressure would not end at a reasonable condensation point for the water component, so that the hot exhaust gas is cooled in the following HRSG to vaporize and superheat steam for the HPT, the pinch point of the HRSG is 25°C at the superheater exit. But after the HRSG only 45 % of the cycle mass flow are further expanded in the LPT. The LPT exit and thus condenser pressure is 0.041 bar.

For a mixture of a condensable (steam) and a non-condensable gas (CO<sub>2</sub>) the condensation temperature depends on the partial pressure of steam, which continuously decreases during the condensation. For a given condenser exit temperature the condenser pressure determines the amount of steam condensed. So in order to maximize the LPT power, the condenser pressure should be reduced so far that only the recycled water is condensed and the combustion water remains in the gaseous phase. At this pressure the LPT produces maximum power, but it is counteracted by an increased effort for compressing the gaseous steam / CO<sub>2</sub> mixture to atmosphere. So for a given condenser exit temperature of 18°C (for a minimum cooling water temperature of 8° C) the

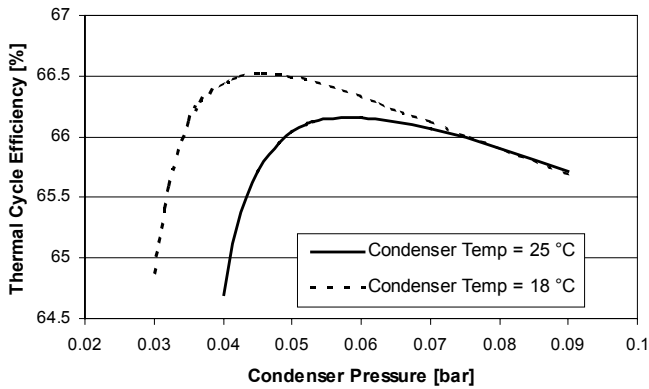

**Fig. 2:** Influence of the condenser pressure on net cycle efficiency

optimum condenser pressure is 0.041 bar, where about half of the combustion water is condensed (see Fig. 2).

Gaseous and liquid phase are separated in the condenser. From there on the gaseous mass flow, which contains the combustion CO<sub>2</sub> and half of the combustion water, is compressed to atmosphere with intercooling and extraction of condensed water, and supplied for further use or storage. At atmosphere the CO<sub>2</sub> purity is 94 %, further water extraction is done during further compression for liquefaction.

After segregating the remaining combustion H<sub>2</sub>O, the water from the condenser is preheated, vaporized and superheated in the HRSG. The steam is then delivered to the HPT at 180 bar and 549 °C. After the expansion it is used to cool the burners and the HTT stages.

The major part of the cycle medium, which is separated after the HRSG, is compressed using an intercooled compressor and fed to the combustion chamber with a maximum temperature of 600°C. The detailed flow sheet used for the thermodynamic simulation is included in the appendix (Fig. 8) and gives mass flow, pressure, temperature and enthalpy of all streams.

The cycle arrangement of the Graz Cycle offers several advantages: On one hand, it allows heat input at very high temperature, whereas on the other hand expansion takes place till to vacuum conditions, so that a high thermal efficiency according to Carnot can be achieved. But only less than half of the steam in the cycle releases its heat of vaporization by condensation. The major part is compressed in the gaseous phase and so takes its high heat content back to the combustion chamber.

Table 2 gives the power balance of the Graz Cycle plant in comparison with the ASME 2004 layout. The new data results in a cycle with a smaller mass flow, so that both turbine and compressor power decrease. But mainly due to the smaller efficiency of the HTT (power decreases by 8.2 MW) the total turbine power decreases more significantly from 150.7 to 142.4 MW, resulting in a reduction of the thermal cycle efficiency from 70.1 to 66.5 %. Accounting for the electrical, mechanical

**Table 2:** Graz Cycle Power Balance

	ASME 04	Actual study
HTT power [MW]	127.6	119.4
Total turbine power P <sub>T</sub> [MW]	150.7	142.4
Total compression power P <sub>C</sub> [MW]	50.2	47.1
Net shaft power [MW] without mechanical losses	100.5	95.3
Total heat input Q <sub>zu</sub> [MW]	143.4	143.4
<b>Thermal cycle efficiency [%]</b>	<b>70.1</b>	<b>66.5</b>
Electrical power output [MW] incl. mechanical, electrical & auxiliary loss	96.9	92.7
<b>Net electrical cycle efficiency [%]</b>	<b>67.6</b>	<b>64.6</b>
O <sub>2</sub> generation & compression P <sub>O<sub>2</sub></sub> [MW]	15.5	14.1
<b>Efficiency considering O<sub>2</sub> supply [%]</b>	<b>56.8</b>	<b>54.8</b>
CO <sub>2</sub> compression to 100 bar P <sub>CO<sub>2</sub></sub> [MW]	2.15	3.15
<b>Net efficiency η<sub>net</sub> [%]</b>	<b>55.3</b> (55.4)	<b>52.6</b>

$$\eta_{net} = \frac{(P_T - P_C) \cdot \eta_m \cdot \eta_{gen} \cdot \eta_{tr} - P_{aux} - P_{O_2} - P_{CO_2}}{Q_{zu} \cdot (1 + \zeta_c)} \quad (1)$$

and auxiliary losses, the net electrical cycle efficiency is 64.6 %, compared to 67.6 %. The now smaller difference between both layouts comes from the different incorporation of the mechanical losses. If considering the efforts for oxygen production and compression to combustion pressure a net efficiency of 54.8 % compared to 56.8 % can be evaluated. If the cycle is penalized with the CO<sub>2</sub> compression to 100 bar for liquefaction, the net efficiency further reduces to 52.6 % (for the efficiency definition see Eq. (1)). The corresponding value in the ASME 2004 paper [12] is 55.3 % and would be 55.4 %, if the same degradation of the thermal cycle efficiency is done. So the difference of 2.7 %-points originates from the higher losses considered in the thermodynamic simulation. But despite this reduced net cycle efficiency, it is higher than that of most other CO<sub>2</sub> capture technologies if evaluated under the same conditions.

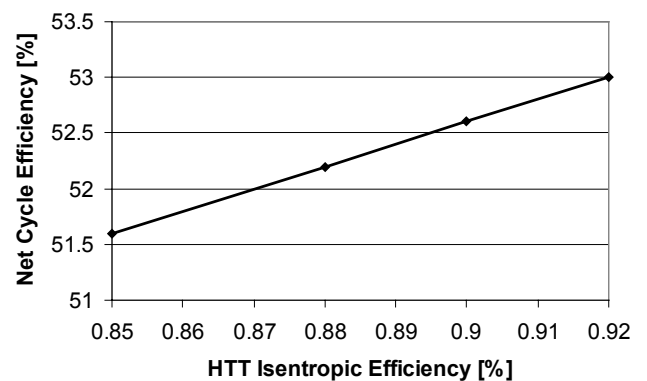

**Fig. 3:** Influence of HTT isentropic efficiency on net cycle efficiency

The comparison between the two layouts based on different assumptions shows the importance of choosing reasonable data for component efficiency and losses to get meaningful results. Two key parameters are the HTT efficiency and HTT cooling mass flow because of the very high power output of this turbine. Fig. 3 shows the influence of the HTT isentropic efficiency. The effect of an improved HTT efficiency is counteracted by the decreased HTT outlet temperature resulting in a decrease of the HPT power output. So assuming an HTT isentropic efficiency of 92 % instead of 90.3 % increases the net efficiency only to 53 % instead of 53.8 %, the value expected by the increase of HTT power output.

On the other hand, the HTT cooling mass flow has a more significant influence on the cycle efficiency. It was estimated to 13.7 % using a model evaluated by comparison with conventional gas turbines, but a percentage-point increase in cooling mass flow decreases the net efficiency by 0.22 %-points. These considerations show that the HTT performance has a decisive influence on the overall cycle efficiency. Therefore, a main object of the feasibility study ordered by Statoil is the detailed investigation of its aerodynamic potential.

#### MODIFICATIONS OF CYCLE CONFIGURATION

In order to improve the efficiency of the Graz Cycle, several modifications were investigated. Following cycle variants are discussed in this work:

- replacement of the single-pressure HRSG by a dual-pressure HRSG
- condensation of the cycle working fluid at 1 bar and re-vaporization of the separated water
- heat supply to the deaerator by the cooling heat of the CO<sub>2</sub> compression intercooler

#### HRSG

The HRSG installed after the HTT provides superheated steam of 180 bar for the HPT. There the steam is expanded to 40 bar and fed to the combustion chamber and the HTT for cooling (see Fig. 1). The second and third HTT stage are cooled with steam of lower pressure, so that about one third of the total cooling mass flow is further expanded to 15 bar (see Fig. 8 in the appendix). This offers the possibility to provide the cooling mass flow via a second HRSG pressure level of either 40 bar for the total cooling mass (44 % of total HRSG mass flow) or of 15 bar (15 % of total HRSG mass flow). For both cases the low pressure superheater is the intercooler of the working fluid compressors.

The simulation results show that the advantage of a smaller mean temperature difference in the HRSG is counteracted by the reduced HPT mass flow and an increased LPT inlet temperature, which cannot be exploited. So both variants result in a slightly reduced cycle efficiency.

The results also show the importance of HPT inlet pressure. The chosen value of 180 bar demands a forced circulation HRSG. If for cost reasons a natural circulation HRSG is used instead, the maximum HPT pressure is limited to

about 130 bar. This would reduce the net cycle efficiency by 0.6 %-points, so that the higher pressure level is chosen.

#### Condensation at 1 bar and water re-vaporization

The CO<sub>2</sub> content of the LPT mass flow is expanded to condenser pressure and afterwards recompressed to atmosphere, so that due to the higher compression effort and additional losses a net loss is generated by this mass flow. Therefore it was suggested in the Austrian patent [18] of the Graz Cycle to condense this mass flow at atmosphere, separate the combustion CO<sub>2</sub> and re-vaporize the water at a reduced pressure level using the condensation heat (see Fig. 4). The steam is then fed to the LPT and expanded to a condenser pressure lower than that for the working fluid mixture.

If the saving of CO<sub>2</sub> compression power and the advantage of a lower condenser pressure exceed the power loss of the LPT due to the reduced mass flow, a gain in efficiency can be achieved. But this condenser/re-evaporator is a component which is yet not available at the market, so that only a remarkable increase in net power justifies this solution. Following variants were investigated:

- -re-vaporization at 0.5 bar
- -re-vaporization at 0.3 bar
- -dual-pressure re-vaporization at 0.5/0.3 bar

The investigation was done for the data of the syngas fired S-Graz Cycle presented at the ASME in Vienna [12], where the situation is more favorable due to the high condenser pressure of 0.085 bar and the high CO<sub>2</sub> content. A second case with a reduced condenser pressure of 0.06 bar, which can be achieved for the same condenser exit temperature of 20°C, is also investigated. For the re-vaporization case the optimum pressure is found with 0.3 bar, which allows a higher superheating than for e.g. 0.5 bar due to the pinch point limitation.

Fig. 5 shows the remarkably higher enthalpy head available for the lower condenser pressure. The best solution can be achieved for a dual pressure re-vaporization at 0.3/0.5 bar (Case 3 in Fig. 5).

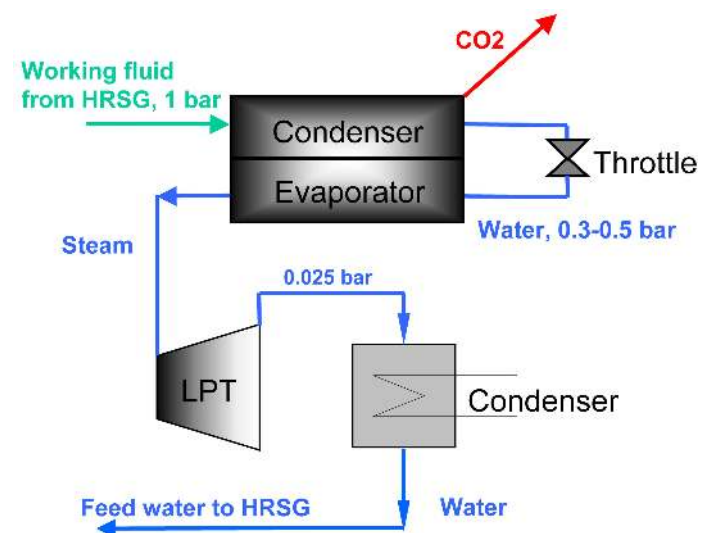
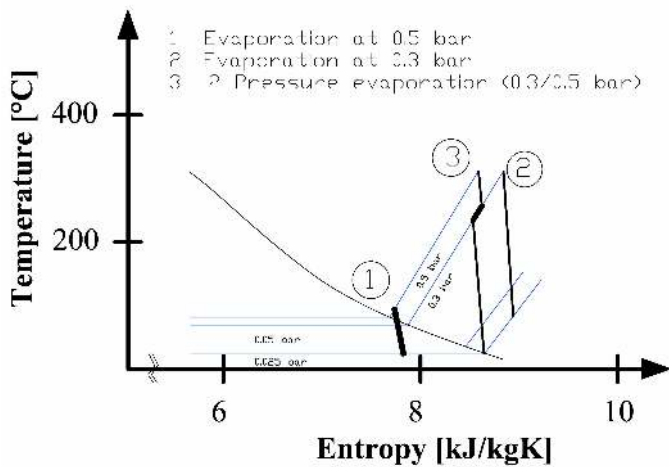

Fig. 4: Scheme of condensation/re-vaporization



**Fig. 5:** Enthalpy head for different cases of re-vaporization

Table 3 shows the net power output as the difference between LPT power and CO<sub>2</sub> recompression effort (only for standard configuration). Only the dual-pressure case (Case 4) gives a slight gain in net power of 600 kW compared to the Vienna layout (Case 1). But if the condenser pressure is reduced to 0.06 bar (Case 2), there is no efficiency gain for the condenser/re-evaporator configuration. So for the layout presented in this work with an even lower condenser pressure no improvement is expected.

**Table 3:** Net power output for different variants

	Net power [MW]	Condenser pressure [bar]
Case 1: Standard configuration 1	11.3	0.085
Case 2: Standard configuration 2	11.9	0.06
Case 3: Re-vaporization at 0.3 bar	10.75	0.025
Case 4: Re-vaporization 0.3/0.5 bar	11.9	0.025

#### Deaerator heating by CO<sub>2</sub> compression intercooler

In order to remove dissolved gases (N<sub>2</sub>, O<sub>2</sub> and CO<sub>2</sub>) in the HRSG feed water a deaerator is arranged in front of the feed pump. Since there is no pure steam at appropriate pressure available for heating, the feed water is heated close to saturation temperature in a surface heat exchanger using working fluid extracted in front of the LPT (see Fig. 8 in the appendix). Since this fluid passes by the LPT reducing its power output, it is investigated, if this extraction can be replaced by supplying heat from the CO<sub>2</sub> compression intercoolers (Fig. 6).

Fig. 9 in the appendix shows the simulation details of a deaeration using the CO<sub>2</sub> compression intercoolers for deaeration. The compression is done with four compressors with the pressure steps 0.04 – 0.2 bar, 0.19 – 1.03 bar, 1 – 15 bar and 14.55 – 103 bar to compress the combustion generated

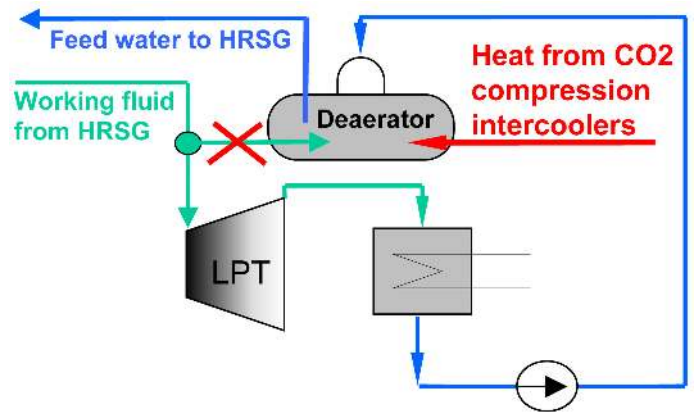

**Fig. 6:** Scheme of deaerator supplied with heat from CO<sub>2</sub> compression intercoolers

CO<sub>2</sub> to 100 bar for liquefaction. The first intercooler heats the feed water from 18° to 60 °C, the water condensation of about a fourth of the hot-side mass flow prevents a further temperature increase. In the next three coolers the feed water is heated to 68 °C, 85°C and finally up to 95°C, close to saturation, so that favorable conditions for the feed water deaeration are achieved. Since the feed water cannot cool the CO<sub>2</sub> stream down to ambient, additional heat exchangers have to be arranged. Although the cycle scheme is more complicated, only water at atmospheric pressure has to be transported, so that the use of a carrier fluid between intercoolers and deaerator is not necessary.

The thermodynamic simulation shows that the heat from the CO<sub>2</sub> intercoolers can completely replace the extraction in front of the LPT. So the mass flow and thus the power output of the LPT increase by 8.5 %, resulting in an increase of net cycle efficiency by 0.8 %-point up to 53.4 %. This improvement makes a further investigation of this concept worthwhile.

#### **COMPONENT DESIGN**

The gases we have to deal with in a Graz Cycle power plant, CO<sub>2</sub> and H<sub>2</sub>O steam, are very compressible at the given high enthalpy heads or pressure ratios. The resulting high changes in volume flow in the individual compressors and turbines require a multi-shaft arrangement connected by gears. At the ASME 2004 conference [12] a turbomachinery arrangement for the S-Graz Cycle power plant was presented with two independent shafts.

On the first shaft the power of all four compressors is balanced with the HTT first stage and the HPT. Both turbines drive the cycle medium compressors C1 and C2 and in normal operation also the CO<sub>2</sub> delivering compressors C3 and C4. The stages 2, 3 and 4 of the HTT run at 12 000 rpm and deliver their power via the main gear to the generator, which is driven on the other side by the LPT in a way quite similar to very large steam turbines.

The new layout does not change the turbomachinery arrangement as proposed in [12]. The HTT first stage is designed to run at a very high speed of 23 000 rpm at transonic

flow conditions, leading to very high stresses in the disk [19]. Therefore, alternatively a two-stage design instead of the now proposed first stage is investigated which would reduce centrifugal forces and lower the flow velocities, but on the other hand would increase the cooling flow demand.

The second non-standard component is the combustion chamber. Its objective is to achieve nearly stoichiometric combustion of fossil fuel and oxygen at 40 bar. The inert cooling medium is a mixture of steam and CO<sub>2</sub>. Recent investigations on such a combustion chamber are reported in [20, 21] for an operating pressure of 10 bar and an exhaust temperature of 1200 °C. The thermal output was about 1 MW. The conclusions of these experiments are very promising: "The combustor was easier to develop than thought at first and performed better in terms of CO than expected. It was not any more difficult to operate than a regular combustor, except for some issues with getting the igniter wet – easily addressed in a full application [22]." In summary, the tests showed that the concept of oxy-fuel combustion using steam dilution is viable.

## ECONOMIC EVALUATION

Despite the high efficiency and the positive impact on the environment by a Graz Cycle power plant, a future application of this technology and an erection of a power plant mainly depends on the economical balance. The main indicator characterizing the economical performance of a power plant for CO<sub>2</sub> capture are the mitigation costs. They represent the increased capital and operational costs incurred by new and additional equipment and lower cycle efficiencies in relation to the CO<sub>2</sub> mass flow avoided. The CO<sub>2</sub> captured has an economic value of about 10 \$/ton, if it can be used for enhanced oil recovery (EOR) or of about 30 \$/ton in the future CO<sub>2</sub> emission trading scenario. These prices show the momentary threshold for the economic operation of zero emission power plants.

In order to estimate the mitigation costs for a Graz Cycle plant, an economic comparison with a high efficiency state-of-the-art combined cycle power plant has to be performed. Economic data reported in [23] were taken as reference, where four different studies evaluating natural gas combined cycle power plants were compared. Since the data differ remarkably between the different cases, following mean cost model is assumed [12]: 1) the yearly operating hours is assumed at 6500 hrs/yr; 2) the capital charge rate is 15%/yr; 3) natural gas fuel costs are 1.3 ¢/kWh<sub>th</sub>; 4) the investment costs per kW are the same for the reference plant of 790 MW net power output and the Graz Cycle plant; 7) additional investment costs are assumed for the air separation unit, for additional equipment and CO<sub>2</sub> compression to 100 bar (see Table 4, [24]); 8) the costs of CO<sub>2</sub> transport and storage are not considered because they depend largely on the site of a power plant.

Table 5 shows the result of the economic evaluation. Compared to the reference plant, the capital costs are about 50 % higher only by considering the additional components for O<sub>2</sub> generation and CO<sub>2</sub> compression. The O&M costs are assumed

**Table 4:** Estimated investment costs

Component	Scale parameter		Specific costs
<b>Reference Plant [23]</b>			
Investment costs	Electric power	\$/kW <sub>el</sub>	414
<b>Graz Cycle Plant</b>			
Investment costs	Electric power	\$/kW <sub>el</sub>	414
Air separation unit [24]	O <sub>2</sub> mass flow	\$/kg O <sub>2</sub> /s	1 500 000
Other costs (Piping, CO <sub>2</sub> -Recirc.) [24]	CO <sub>2</sub> mass flow	\$/kg CO <sub>2</sub> /s	100 000
CO <sub>2</sub> -Compression system [24]	CO <sub>2</sub> mass flow	\$/kg CO <sub>2</sub> /s	450 000

**Table 5:** Economic data

	Reference plant [23]	S-GC base version
<b>Reference Plant</b>		
Plant capital costs [\$/kW <sub>el</sub> ]	414	414
Addit. capital costs [\$/kW <sub>el</sub> ]		220.5
CO <sub>2</sub> emitted [kg/kWh <sub>el</sub> ]	0.37	0.0
Net plant efficiency [%]	56.2	52.6
COE for plant amort. [¢/kWh <sub>el</sub> ]	0.96	1.46
COE due to fuel [¢/kWh <sub>el</sub> ]	2.31	2.47
COE due to O&M [¢/kWh <sub>el</sub> ]	0.7	0.8
<b>Total COE [¢/kWh<sub>el</sub>]</b>	<b>3.97</b>	<b>4.74</b>
<b>Comparison</b>		
<b>Differential COE [¢/kWh<sub>el</sub>]</b>		<b>0.77 (+ 19 %)</b>
<b>Mitigation costs [\$/ton CO<sub>2</sub> capt.]</b>		<b>20.7</b>

15 % higher for a Graz Cycle plant due to the operation of additional equipment. The table shows that fuel costs contribute mostly to the costs of electricity (COE), but the main difference is caused by the investment costs.

Based on these assumptions, the COE of a natural gas fired Graz Cycle plant of 52.6 % net efficiency is 0.77 ¢/kWh<sub>el</sub> higher than for the reference plant, i.e. an increase of 19 %. The mitigation costs are 20.7 \$/ton of CO<sub>2</sub> avoided, if CO<sub>2</sub> liquefaction is considered. This value is clearly below the threshold value of 30 \$/ton showing the economic potential of the Graz Cycle. If the deaeration heat can be supplied by the CO<sub>2</sub> compression intercooling, reduced mitigation costs of 19.7 \$/ton CO<sub>2</sub> avoided can be expected.

The results of the economic study depend mainly on the assumptions about investment costs, fuel costs and capital charge rate as well as on the choice of the reference plant. A cost sensitivity analysis performed in [12] showed that a variation of the capital costs has the main influence on the economics. In general additional investment costs for zero emission power plants of 50 to 100 % are estimated. If only the additional investment costs for the air separation unit and the

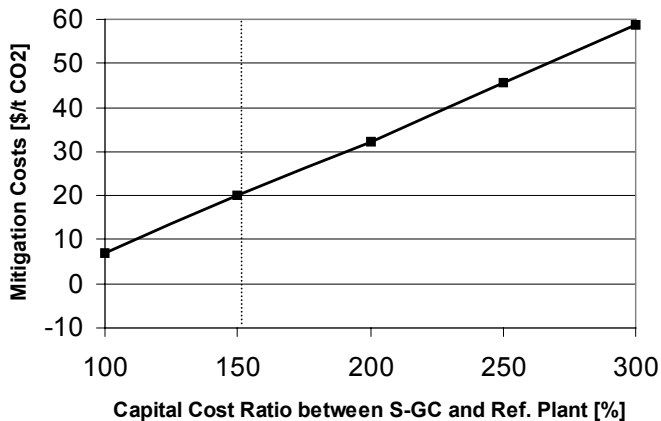

**Fig. 7:** Influence of capital costs on the mitigation costs (CO<sub>2</sub> provided at 100 bar)

CO<sub>2</sub> compression is considered, the capital costs already increase by approximately 50 %. In Fig. 7 a broad variation of the capital costs between 100 % (same investment costs) and 300 % of the reference plant investment costs is shown. If the same investment costs are assumed, the resulting mitigation costs are only 7 \$/ton CO<sub>2</sub>, whereas twice as high investment costs for a Graz Cycle power plant leads already to mitigation costs of 32 \$/ton CO<sub>2</sub> avoided.

This high sensitivity to the capital costs shows the dilemma in performing an exact economic evaluation, since it is very difficult to estimate the capital costs for a Graz Cycle power plant because of new turbomachinery components, i.e. the HTT and the fuel-oxygen combustion chamber. Therefore, it is a main task of the techno-economic study ordered by Statoil to determine a sound estimate of the Graz Cycle investment costs. These costs will be determined assuming a larger number of units sold, so that not all development costs are charged to one unit.

In these considerations about the height of additional investment costs, a further advantage of the Graz Cycle, the almost NO<sub>x</sub>-free combustion was not evaluated. According to [25] exhaust flow NO<sub>x</sub> and CO catalytic reduction to achieve single-digit emissions (in strict attainment areas) can increase gas turbine genset plant costs by 40 to 50 percent.

## CONCLUSIONS

The Graz Cycle is an oxy-fuel power cycle with the capability of retaining all the combustion generated CO<sub>2</sub> for further use. Its high efficiency and reasonable mitigation costs arose interest by end-users of such a plant. The Norwegian oil and gas company Statoil initiated a cooperation in order to conduct a feasibility study together with a major gas turbine manufacturer with the goal of a technical and economic evaluation. In this work the basic thermodynamic assumptions agreed with Statoil for a Graz Cycle plant of high power are shown and the resulting power cycle for natural gas firing is presented. Its net efficiency of 52.6 % is below the first simulations, but is still above most alternative CO<sub>2</sub> capture

technologies. Possible modifications of the cycle scheme are discussed, and a variant using the CO<sub>2</sub> intercooler heat for deaeration promises 53.4 % efficiency.

In an economical analysis the Graz Cycle power plant is compared with a reference plant. The resulting mitigation costs of 20 \$/ton CO<sub>2</sub> are below a threshold value of 30 \$/ton CO<sub>2</sub> (assumed for future CO<sub>2</sub> emission trading), but this value strongly depends on the investment costs assumed. Therefore, a sound cost estimation is needed to decide about the future prospects of a Graz Cycle power plant for CO<sub>2</sub>.

## ACKNOWLEDGMENTS

The authors would like to thank Mr. Arne Lynghjem, Mr. Marius Gjerset and Mr. Jon Jakobsen from Statoil ASA, Norway, for their interest and the fruitful discussions on the Graz cycle, which led to this work.

## REFERENCES

- [1] **Strömberg, L.**, 2003, "Overview of CO<sub>2</sub> Capture and Storage – Technology and Economics for Coal Based Power Generation", VGB Congress 2003, Copenhagen
- [2] **Gabrielli, R., Singh, R.**, 2002, "Thermodynamic Performance Analysis of New Gas Turbine Combined Cycles with no Emissions of Carbon Dioxide", ASME Paper GT-2002-30117, ASME Turbo Expo 2002, Amsterdam, The Netherlands
- [3] **European Commission**, 2004, "European CO<sub>2</sub> Capture and Storage Projects", EU-Brochure EUR 21240
- [4] **Turanskyj, L., Keenan, B.A.**, 2001, "Turbomachinery for the World's Largest Nitrogen Plant: Enhanced Oil Recovery to Increase the Output in the Cantarell Oil Field, Mexico", Paper at the Exposición Latinoamericana del Petróleo, Maracaibo, Venezuela
- [5] **Jericha, H.**, 1985, "Efficient Steam Cycles with Internal Combustion of Hydrogen and Stoichiometric Oxygen for Turbines and Piston Engines", CIMAC Conference Paper, Oslo, Norway
- [6] **Jericha, H., Sanz, W., Woisetschläger, J., Fesharaki, M.**, 1995, "CO<sub>2</sub> - Retention Capability of CH<sub>4</sub>/O<sub>2</sub> – Fired Graz Cycle", CIMAC Conference Paper, Interlaken, Switzerland
- [7] **Jericha, H., Fesharaki, M.**, 1995, "The Graz Cycle – 1500°C Max Temperature Potential H<sub>2</sub> – O<sub>2</sub> Fired CO<sub>2</sub> Capture with CH<sub>4</sub> – O<sub>2</sub> Firing", ASME Paper 95-CTP-79, ASME Cogen-Turbo Power Conference, Vienna, Austria
- [8] **Jericha, H., Lukasser, A., Gatterbauer, W.**, 2000, "Der "Graz Cycle" für Industriekraftwerke gefeuert mit Brenngasen aus Kohle- und Schwerölvergasung" (in German), VDI Berichte 1566, VDI Conference Essen, Germany
- [9] **Jericha, H., Göttlich, E.**, 2002, "Conceptual Design for an Industrial Prototype Graz Cycle Power Plant", ASME



- Paper 2002-GT-30118, ASME Turbo Expo 2002, Amsterdam, The Netherlands
- [10] **Jericha, H., Göttlich, E., Sanz, W., Heitmeir, F.**, 2003, "Design Optimisation of the Graz Cycle Prototype Plant", ASME Paper 2003-GT-38120, ASME Turbo Expo 2003, Atlanta, USA
- [11] **Heitmeir, F., Sanz, W., Göttlich, E., Jericha, H.**, 2003, "The Graz Cycle – A Zero Emission Power Plant of Highest Efficiency", XXXV Kraftwerkstechnisches Kolloquium, Dresden, Germany
- [12] **Sanz, W., Jericha, H., Moser, M., Heitmeir, F.**, 2004, "Thermodynamic and Economic Investigation of an Improved Graz Cycle Power Plant for CO<sub>2</sub> Capture", ASME Paper GT2004-53722, ASME Turbo Expo 2004, Vienna, Austria
- [13] **SimTech Simulation Technology**, 2003, "IpsEpro Overview", <http://www.simtechnology.com/IPSEpro>
- [14] **Wagner, W., Kruse, A.**, "Properties of Water and Steam", Springer-Verlag Berlin Heidelberg New York, 1998
- [15] **Sievers, U.**, 1984, "Die thermodynamischen Eigenschaften von Kohlendioxid (in German)", VDI Verlag, Düsseldorf. Fortschritt-Berichte VDI, Reihe 6, Energietechnik, Nr. 155
- [16] **Jordal, K., Bolland, O., Klang, A.**, 2003, "Effects of Cooled Gas Turbine Modelling for the Semi-Closed O<sub>2</sub>/CO<sub>2</sub> Cycle with CO<sub>2</sub> Capture", ASME Paper 2003-GT-38067, ASME Turbo Expo 2003, Atlanta, USA
- [17] **Luckel, F.**, 2004, "Weiterentwicklung des Graz Cycle und der Vergleich mit anderen CO<sub>2</sub>-Rückhaltekonzepten" (in German), Diploma Thesis, Graz University of Technology
- [18] **Jericha, H., Sanz, W.**, 2001, "Wärmeanlagen mit Verbrennung von Kohlenwasserstoffen mit reinem Sauerstoff zur Stromerzeugung bei Rückhaltung von Kohlendioxid" (in German), Austrian Patent No. AT 409 162 B
- [19] **Jericha, H., Sanz, W., Pieringer, P., Göttlich, E., Erroi, P.**, 2004, "Konstruktion der ersten Stufe der HTT-Gasturbine für den Graz Cycle" (in German), VDI Berichte 1857, VDI Tagung "Stationäre Gasturbinen: Fortschritte und Betriebserfahrungen", Leverkusen
- [20] **Chorpening, B.T., Casleton, K.H., Richards, G.A.**, 2003, "Stoichiometric Oxy-Fuel Combustion for Power Cycles With CO<sub>2</sub> Sequestration", Proceedings of the Third Joint Meeting of the U.S. Sections of The Combustion Institute, Chicago, IL
- [21] **Chorpening, B.T., Richards, G.A., Casleton, K.H., Woike, M., Willis, B., Hoffman, L.**, 2003, "Demonstration of a Reheat Combustor for Power Productin With CO<sub>2</sub> Sequestration", ASME Paper 2003-GT-38511, ASME Turbo Expo 2003, Atlanta, USA
- [22] **Richards, G.A.**, 2004, private communications
- [23] **David, J.**, 2000, "Economic Evaluation of Leading Technology Options for Sequestration of Carbon Dioxide", Master Thesis, Massachusetts Institute of Technology
- [24] **Göttlicher, G.**, 1999, "Energetik der Kohlendioxidrückhaltung in Kraftwerken" (in German), Fortschritt-Berichte VDI, Reihe 6, Energietechnik, Nr. 421. Düsseldorf: VDI Verlag
- [25] **Gas Turbine World**, 2003, "2003 Handbook for Project Planning, Design and Construction", Pequot Publishing Inc.

# APPENDIX

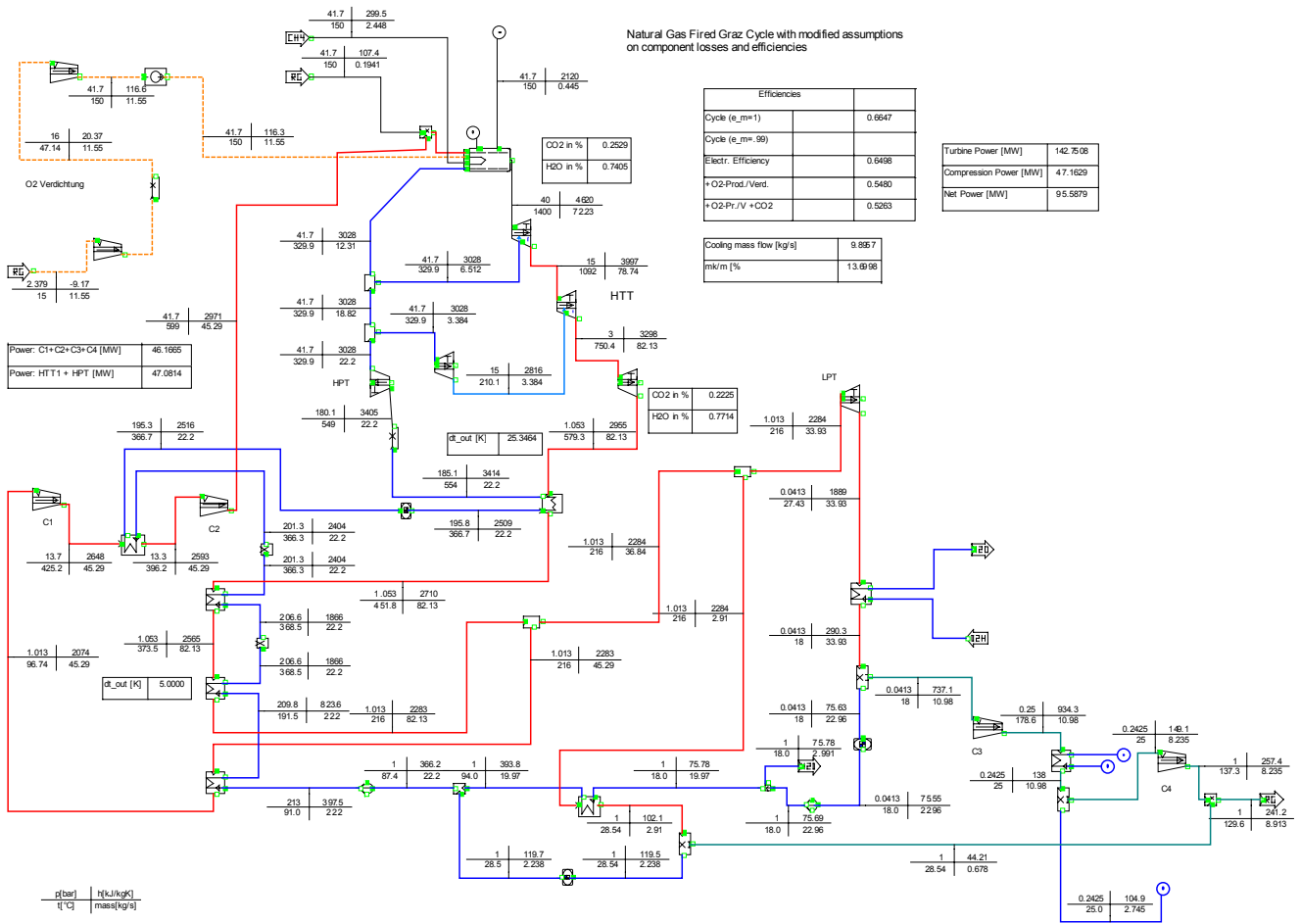

**Fig. 8:** Detailed thermodynamic cycle data of a Graz Cycle power plant based on modified component efficiencies and losses

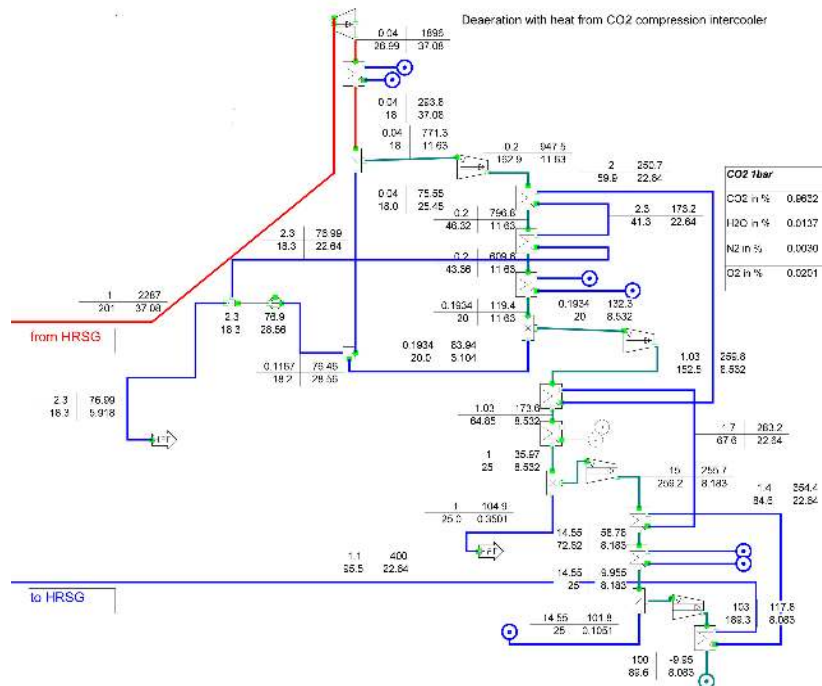

**Fig. 9:** Deaeration using heat from CO<sub>2</sub> compression intercoolers (thermodynamic simulation)