

A Hybrid Approach for Radio Resource Management in Heterogeneous Cognitive Networks

Majed Haddad, Salah Eddine Elayoubi, Eitan Altman, *Fellow, IEEE*, and Zwi Altman, *Senior Member, IEEE*

Abstract—Distributing Radio Resource Management (RRM) in heterogeneous wireless networks is an important research and development axis that aims at reducing network complexity. In this context, RRM decision making can be delegated to mobiles by incorporating cognitive capabilities into mobile handsets, resulting in the reduction of signalling and processing burden. This may however result in inefficiencies (such as those known as the “tragedy of commons”) that are inherent to equilibria in non-cooperative games. Due to the concern for efficiency, centralized network architectures and protocols keep being considered and being compared to decentralized ones. From the point of view of the network architecture, this implies the co-existence of network-centric and terminal-centric RRM schemes. Instead of taking part within the debate among the supporters of each solution, we propose in this paper hybrid schemes where the wireless users are assisted in their decisions by the network that broadcasts aggregated load information. At some system’s states, the network manager may impose his decisions on the network users. In other states the mobiles may take autonomous actions in reaction to information sent by the network. In order to improve the performance of the non-cooperative scenario, we investigate the properties of an alternative solution concept named Stackelberg game, in which the network tries to control the users’ behavior by broadcasting appropriate information, expected to maximize its utility, while individual users maximize their own utility. We derive analytically the utilities related to the Quality of Service (QoS) perceived by mobile users and develop a Bayesian framework to obtain the equilibria. Numerical results illustrate the advantages of using our hybrid game framework in an association problem in a network composed of HSDPA and 3G LTE system that serve streaming and elastic flows.

Index Terms—Radio spectrum management, game theory, distributed algorithms, cognitive radio.

I. INTRODUCTION

THE EVOLUTION of Next Generation (NG) Radio Access Networks (RANs) are driven by new applications and services with increasing demand for bandwidth, for ubiquitous service provisioning and for reduced cost. NG RANs will operate in highly heterogeneous landscape with different radio access technologies including IEEE networks (e.g. WiMax, Wifi) and 3GPP ones (e.g. UMTS, HSDPA, LTE), with hierarchical cell structures for macro/micro/pico/femto deployments. In this context, efficient network management in

general and Radio Resource Management (RRM) in particular become strategic for the operator. Self-Organizing Network (SON) is currently considered as a key lever to reduce complexity and cost of network management, to improve (inter-) operability, and to reduce cost of operation. Different standardization bodies have picked up this topic, and SON functionalities are expected to become widely commercially available with the introduction of 4G networks [1].

Distributing RRM functions by delegating the decision making concerning network resource utilization to the mobiles is one of the important avenues to reduce network complexity, signaling and processing load in heterogeneous environments. Performing decision making involves incorporating cognitive capabilities into the mobiles such as sensing the environment and learning capabilities. This falls within the larger framework of cognitive radio [2] and SON (or cognitive networks). The main goal of cognitive radio is to enhance spectral efficiency by overlaying a new mobile radio system on an existing one without requiring any changes to the actual licensed system while improving network quality [3]. As explained below, the network can guide the decision taken by the mobiles and in this sense, the network is a cognitive network.

In this paper, we investigate the association problem in the context of distributed decision making in a heterogeneous cognitive network. We wish to avoid completely decentralized solutions of the association problem in which all decisions are taken by the mobiles, due to well known inefficiency problems that may arise when each mobile is allowed to optimize its own utility. This inefficiency is inherent to the non-cooperative nature of the decision making. Nevertheless, we wish to delegate to the mobiles a large part in the decision making in order to alleviate the burden from the base stations.

We then propose association methods that combine benefits from both decentralized and centralized design. Central intervention is needed during severe congestion periods. At those instants, we assume that the mobiles follow the instructions of the base stations. Otherwise the association decision is left to the mobiles, which make the decision based on aggregated load information. The decision making is thus based on partial information that is signaled to the mobiles by the base station. A central design aspect is then for the base stations to decide how to aggregate information which then determines what to signal to the users. This decision making at the BS can be viewed as a mechanism design problem, or as a Bayesian game (in the case we wish to view the base station as a player on his own). We will exemplify our general analysis by investigating the possibility of offering real time or non-real time services.

Manuscript received 1 December 2009; revised 28 April 2010. This work was done while Majed Haddad was with France Telecom R&D, as postdoctoral research fellow. The material in this paper was presented in part at the IEEE INFOCOM, San Diego, CA, USA 2010.

E. Altman and M. Haddad are with MAESTRO, INRIA Sophia-Antipolis, 10 route des Lucioles, 06902 Sophia-Antipolis, France (e-mail: majed.haddad, eitan.altman@sophia.inria.fr).

S. E. Elayoubi and Z. Altman are with France Telecom R&D, 38-40 Rue du General Leclerc, 92130 Issy-Les-Moulineaux, France (e-mail: salaheddine.elayoubi, zwi.altman@orange-ftgroup.com).

Digital Object Identifier 10.1109/JSAC.2011.110414.

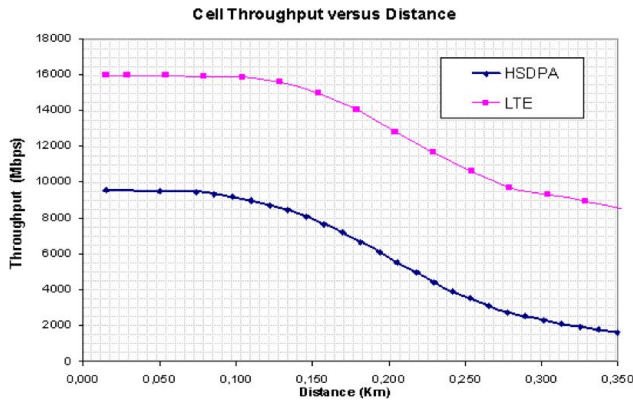

Fig. 1. LTE and HSDPA peak throughputs as function of user positions in the cell.

In order to be able to achieve these goals, we make use of the IEEE SCC41 standard framework [4] and particularly the IEEE standard 1900.4 [5] that proposes scenarios and solutions to allow information exchange between the network and the end-user terminals; the aim is to allow devices to optimally choose among the available radio resources so that the overall efficiency and capacity of the resulting composite network is improved. The proposal to introduce a logical communication channel between Network Reconfiguration Manager (NRM) and the Terminal Reconfiguration Manager (TRM), e.g. the *radio enabler*, into heterogeneous wireless systems is one of the main outcomes of the IEEE standard 1900.4 (see Fig. 2). The objective is to support an efficient discovery of the available radio accesses and reconfiguration management in heterogeneous wireless environment between the NRM and the TRM. Note that the approach proposed in this paper, while profiting from the IEEE standard 1900.4 capabilities, presents a key to understand the actual benefits brought by this standard. In fact, although IEEE standard 1900.4 have spurred great interest and excitement in the community, many of the fundamental theoretical questions on the limits of such a standard remain unanswered.

RELATED WORK

When we deal with heterogeneous cognitive networks, interactions among selfish users sharing a common transmission channel can be modeled as a non-cooperative game using the game theory framework [6]. Game theory provides a formal framework for studying the interactions of strategic agents. Recently, there has been a surge in research activities that employ game theory to model and analyze a wide range of application scenarios in modern communication networks [7], [8].

Moreover, radio access equipment is becoming more and more multi-standard, offering the possibility of connecting through two or more technologies concurrently. Switching between networks using different technologies is referred to as *vertical handover*. The association schemes actually implemented by network operators are fully centralized: the operator tries to maximize his utility (revenue) by assigning the users to the different systems [9], [10], [11]. However, distributed joint radio resource management (JRRM) mechanisms are gaining

in importance: Users may be allowed to make autonomous decisions in a distributed way. The association problem is related in nature to the channel selection problem. We note that when a single technology is used or, when the decision concerns the choice of channels of a given access point rather than the choice of an access point, one can often exploit simpler structure of the decision problem and obtain efficient decentralized solutions. Some examples of work in that direction are [12], [13], [14]. This has lead game theoretic approaches to the association problems in wireless networks, as can be found in [15], [16], [17], [18], [19], [20]. The potential inefficiency of such approaches have been known for a long time. In fact, this could likely lead to congestion and overload conditions in the RAT in question (which offers the best peak rate) and all users would lose. The term "The Tragedy of the Commons" has been frequently used for this inefficiency [21]; it describes a dilemma in which multiple individuals acting independently in their own self-interest can ultimately destroy a shared limited resource even when it is clear that it is not in anyone's long term interest for this to happen. To overcome this hurdle, we introduce a game theoretic framework with partial information to maximize the throughput while taking into account the system overload. This study requires particular attention when all users wish to maximize their individual throughput but each has a different approach (e.g. users may have different tolerance for delay, or may have a certain target throughput to guarantee).

The basic idea of the hybrid decision approach has been first presented in [22] where the association problem was formulated as a non-cooperative game. In the present contribution, we prove formally that the Nash equilibrium exists in the case of mixed strategies. We further extend the model by allowing the network to control the users' behavior by choosing the information he broadcasts and formulate it as a Stackelberg game. The network model is extended to include intra- and inter-system mobility of users. We also present a detailed calculation of the individual utilities in the most general case, for both streaming and elastic services.

This paper is structured as follows. The association problem in heterogeneous cognitive networks is exposed in Sec. II. In Sec. III, we calculate the utility of the wireless users by a Markov analysis. In Sec. IV, we present the non-cooperative game framework adapted for the considered hybrid model and show how the base station can control the equilibrium of its users by means of a Stackelberg formulation. In Sec. V, we provide numerical results to illustrate the theoretical solutions derived in the previous sections for both streaming and elastic flows. Sec. VI eventually concludes the paper.

II. HYBRID DECISION FRAMEWORK

A. Network resources

Consider a wireless network composed of S systems managed by the same operator. Consider $\mathcal{S} = \{1, \dots, S\}$ as the set of all serving systems within the network. Clearly, the peak throughput that can be obtained by a user connected to system s , if served alone by a cell, differs depending on its position in the cell. This is illustrated in Figure 1, showing the peak throughputs for a cell served by HSDPA and 3G LTE

as an example. In order to have realistic expressions of the effective throughput on each system and to include the impact of mobility on the performance, we decompose the cell into N location areas corresponding to concentric circles of radius d_n for $n = 1, \dots, N$ with homogeneous radio characteristics. Let $\mathcal{N} = \{1, \dots, N\}$ a set of N classes of radio conditions. Users with radio condition $n \in \mathcal{N}$ have a peak rate D_n^s if connected to system $s \in \mathcal{S}$. Let $\mathcal{F} = \mathbb{N}^{N \times S}$, the $(N \times S)$ network state matrix \mathbf{M} is defined by the number of users with different radio conditions in each system:

$$\mathbf{M} = \begin{pmatrix} M_1^1 & M_1^2 & \cdot & \cdot & M_1^S \\ M_2^1 & \cdot & \cdot & \cdot & M_2^S \\ \cdot & \cdot & M_n^s & \cdot & \cdot \\ \cdot & \cdot & \cdot & \cdot & \cdot \\ M_N^1 & \cdot & \cdot & \cdot & M_N^S \end{pmatrix} \quad (1)$$

where M_n^s represents the number of users with radio condition $n \in \mathcal{N}$ connected to system $s \in \mathcal{S}$. Depending on the required service, some of these network states (referred to hereafter and interchangeably, as micro-states) are not admissible in the sense that the time-frequency resources are not sufficient to meet the service requirements of all mobiles given their location and radio conditions. We denote¹ by $\mathcal{A} \subset \mathcal{F}$ the corresponding state space composed of all admissible network states.

B. Cognitive channel signalling information

The network is fully characterized by its state \mathbf{M} . However, when distributing the RRM decisions, this complete information is not available to the users. In this setting, we assume that, using the *radio enabler* proposed by the IEEE standard 1900.4, the NRM broadcasts to the TRM an aggregated load information that takes values in some finite set $\mathcal{L} = \{1, \dots, L\}$ indicating in which load state mobile terminals are (low, medium or high) (see Figure 2). This reduces signalling overhead while staying inline with the IEEE standard 1900.4 requirements which specifies that “*the network manager side shall periodically update the terminal side with context information*” [5]. More formally, an assignment $f : \mathcal{F} \rightarrow \mathcal{L}$ specifies for each network micro-state \mathbf{M} the corresponding macro-state $f(\mathbf{M})$. We will call $f(\cdot)$ the *load information function*. As an example, Figure 2 shows how the load information is aggregated by the NRM to the TRM for a network composed of two systems (HSDPA and LTE), indicating for each system if it is in a low, medium, or high load state. This figure illustrates the relationship between the loads of the systems \mathbf{M} and the corresponding load information $l = f(\mathbf{M})$. In particular, a function f is constructed based on four thresholds: L_1 , L_2 , H_1 and H_2 . The load of system X is considered low if it is less than threshold X_1 , medium if it is between X_1 and X_2 and high if it is larger than X_2 where $X = L$ for LTE and $X = H$ for HSDPA. The load information l , an integer between 1 and 9, is then obtained and broadcasted to mobile users.

¹The set of admissible states will be discussed in more details in Section III-A1.

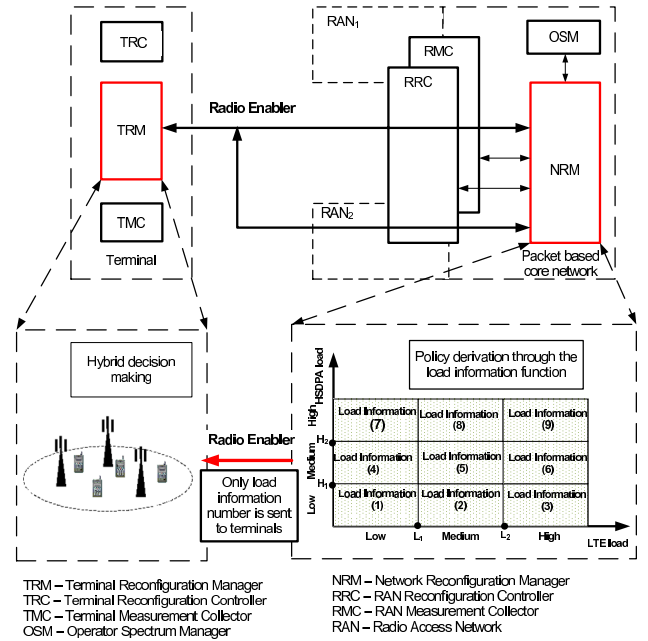

Fig. 2. The proposed hybrid 1900.4 system description.

C. RRM policies

Mobiles arrive in the network at random, attempt a call and leave the network immediately if blocked or persist until the end of the call if admitted. Within the space of admissible states \mathcal{A} , each mobile will decide *individually* to which of the available systems it is best to connect according to its radio condition and the load information l broadcast by the network. Their policies² (or strategies) are then based on this information. Let $\mathbf{P}^l = [P_{1,l}, \dots, P_{N,l}]^T$ be the user’s decision vector, knowing the aggregated load information l , whose element $P_{n,l}$ is equal to s if class- n users connect to system s . The set of all possible choices is \mathcal{P} . We then denote by $\mathbf{P} \in \mathcal{P}$ the strategy profile matrix defined as the actions taken by mobiles in the different load conditions. Equivalently, when the network load information is equal to l and the strategy profile is \mathbf{P} , we can determine the system to which users of class n will connect by the value $P_{n,l}$. As an example, knowing the function $f(\cdot)$ and the strategy profile \mathbf{P} , if the network is in state \mathbf{M} , a class n user will connect to system $P_{n,l}$ where $l = f(\mathbf{M})$. Note that, if the function f is modified, the groups of states that are aggregated within the same macro-state are changed, leading to a different JRRM decision taken by a user that finds the system in micro-state \mathbf{M} for the same policy \mathbf{P} .

Both admission control and vertical handovers can be involved: upon arrival, each user decides its serving system following the actual policy \mathbf{P} and the load information function f . The association problem is then generalized to allow the mobile users to change their new serving system according to the aggregated load information while taking into account the reduction of unnecessary handovers, namely the *ping-pong effect*. Vertical handovers are possible only following changes in the radio conditions of a given mobile in an *event-driven* manner. The migrating mobiles check, once their

²In the following, we use the term policy and strategy interchangeably.

radio conditions change, whether the serving radio access technology (RAT) is still the best choice according to its policy. Otherwise, it can perform an inter-system handover to the other RAN after checking that it could be admitted on it.

III. UTILITIES

The first step before analyzing the hybrid decision scheme is to define the utilities of users. These latter are often related to throughput, whose variations are mainly due to network load, radio network conditions and mobility such as handovers. Let us first begin by analyzing a system offering streaming calls, the case of elastic (FTP-like) calls will be studied next.

A. Steady state analysis

We consider a Real-time Transport Protocol (RTP) streaming service. As we consider cellular networks where Adaptive Modulation and Coding (AMC) ensure that the Block Error Rate (BLER) is lower than a certain target, the video quality is guaranteed when the throughput required by the codec is obtained. The goal of a streaming user is thus to achieve the best throughput, knowing that the different codecs allow a throughput between an upper (best) T_{max} and a lower (minimal) T_{min} bounds. His utility is expressed by the quality of the streaming flow he receives, which is in turn closely related to his throughput. Indeed, a streaming call with a higher throughput will use a better codec offering a better video quality. This throughput depends not only on the peak throughput, but also on the evolution of the number of calls in the system where the user decides to connect. Note that a user that cannot be offered this minimal throughput in neither of the available systems is blocked in order to preserve the overall network performance. However, once connected, we suppose that a call will not be dropped even if its radio conditions degrade because of mobility. For the ease of comprehension, we will begin by considering static users. Mobility is introduced later in Section III-D.

1) *Instantaneous throughput*: The instantaneous throughput obtained by a user in a system depends on both his own decisions and the decisions taken by the other users. Assuming proportional fair scheduling among different users, the throughput of a user with radio condition class n connected to system s is given by:

$$t_n^s(\mathbf{M}) = \min \left[D_n^s \frac{G(\mathbf{M})}{\sum_{n=1}^N M_n^s}, T_{max} \right] \quad (2)$$

where $G(\mathbf{M})$ is the opportunistic scheduler gain. Note here that the admission control will ensure that $t_n^s(\mathbf{M}) \geq T_{min}$ by blocking new arrivals. The space of admissible states \mathcal{A} is thus the set of all states \mathbf{M} where the minimal constraint on the throughput is ensured:

$$\frac{G(\mathbf{M})}{\sum_{n=1}^N M_n^s} \geq \frac{T_{min}}{D_n^s}, \forall n, s | M_n^s > 0 \quad (3)$$

Note that $T_{min} < T_{max}$, so that the states where $t_n^s(\mathbf{M}) = T_{max}$ verify the latter condition.

2) *Steady state probabilities*: The throughput achieved by a user depends on the number of ongoing calls. This latter is a random variable whose evolution is described by a Markov chain governed by the arrival and departure processes. We assume that the arrival process of new connections with radio condition n is Poisson with rate λ_n uniformly distributed over the cell. Each arriving user makes a streaming connection whose duration is exponentially distributed with parameter $1/\mu$. Within the space of feasible states \mathcal{A} , transitions between states are caused by the departures, the arrivals and the subsequent decisions determined by the policy:

- Arrivals of new connections of radio condition n . Let $\mathcal{G}_n^s(\mathbf{M})$ denote the state of the system if we add one mobile of radio condition n to system s . The transition from state \mathbf{M} to $\mathcal{G}_n^s(\mathbf{M})$ happens if the policy implies that system s is to be chosen for the load information corresponding to state \mathbf{M} , and if the state $\mathcal{G}_n^s(\mathbf{M})$ is an admissible state. The corresponding transition rate is thus equal to:

$$q(\mathbf{M}, \mathcal{G}_n^s(\mathbf{M}) | \mathbf{P}, f) = \lambda_n \cdot \mathbb{I}_{P_{n,f(\mathbf{M})=s}} \cdot \mathbb{I}_{\mathcal{G}_n^s(\mathbf{M}) \in \mathcal{A}} \quad (4)$$

where \mathbb{I}_C is the indicator function equal to 1 if condition C is satisfied and to 0 otherwise,

- End of a communication of class (n, s) . Let $\mathcal{D}_n^s(\mathbf{M})$ denote the state with one less mobile of class (n, s) . The transition from state \mathbf{M} to $\mathcal{D}_n^s(\mathbf{M})$ is equal to:

$$q(\mathbf{M}, \mathcal{D}_n^s(\mathbf{M}) | \mathbf{P}, f) = M_n^s \cdot \mu \cdot \mathbb{I}_{M_n^s > 0} \quad (5)$$

These transitions are illustrated in Figure 3. The transition matrix $\mathbf{Q}(\mathbf{P}, f)$ of the Markov chain can then be easily written for each policy \mathbf{P} knowing that its diagonal element is equal to:

$$q(\mathbf{M}, \mathbf{M} | \mathbf{P}, f) = - \sum_{n=1}^N \sum_{s=1}^S [q(\mathbf{M}, \mathcal{D}_n^s(\mathbf{M}) | \mathbf{P}, f) + q(\mathbf{M}, \mathcal{G}_n^s(\mathbf{M}) | \mathbf{P}, f)] \quad (6)$$

The steady-state distribution is then obtained by solving the following equation:

$$\begin{cases} \mathbf{\Pi}(\mathbf{P}, f) \cdot \mathbf{Q}(\mathbf{P}, f) = 0 \\ \mathbf{\Pi}(\mathbf{P}, f) \cdot \mathbf{e} = 1; \end{cases} \quad (7)$$

where $\mathbf{\Pi}(\mathbf{P}, f)$ is the vector of the steady-state probabilities $\pi(\mathbf{M} | \mathbf{P}, f)$ under policy \mathbf{P} and load information function f , and \mathbf{e} is a vector of ones of appropriate dimension. Numerical resolution of this problem is possible, and once the vector $\mathbf{\Pi}$ is obtained, the global performance indicators can be calculated. Among these performance metrics, we can cite the blocking rate of class- n calls knowing that the load information is equal to l :

$$b_n(l | \mathbf{P}, f) = \frac{\sum_{\mathbf{M} \in \mathcal{A}; \mathcal{G}_n^s(\mathbf{M}) \notin \mathcal{A}, \forall s \in \mathcal{S}} \pi(\mathbf{M} | \mathbf{P}, f)}{\sum_{\mathbf{M} \in \mathcal{A}; f(\mathbf{M})=l} \pi(\mathbf{M} | \mathbf{P}, f)} \quad (8)$$

In this equation, we consider as blocked all calls that arrive in states where each system are saturated, i.e., where $t_n^s(\mathbf{M}) < T_{min}$. We can also obtain the overall blocking rate:

$$b(\mathbf{P}, f) = \sum_{n=1}^N \frac{\lambda_n}{\sum_{m=1}^N \lambda_m} b_n(l | \mathbf{P}, f) \quad (9)$$

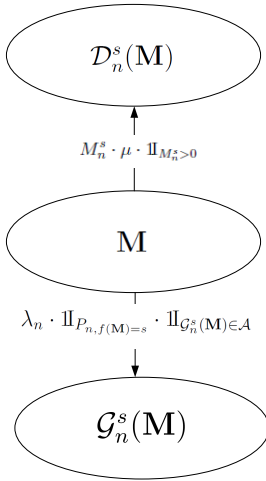

Fig. 3. Transitions of the Markov chain. We only illustrate arrivals and departures corresponding to matrix state \mathbf{M} : Arrival transitions occur only if the policy \mathbf{P} implies that users with radio conditions n connect to system s .

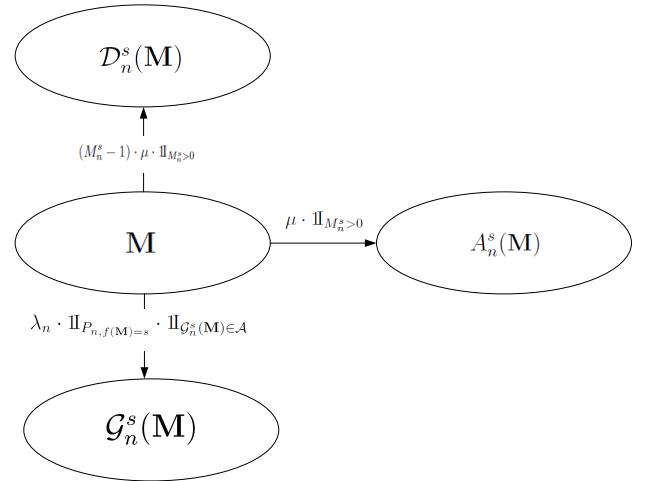

Fig. 4. Transitions of the Markov chain, modified to calculate utilities of calls (n, s) . Notice that departures to the absorbing state are added with respect to the Markov chain in Fig. 3.

B. Transient analysis

The steady-state analysis described above is not sufficient to describe the utility of the users as the throughput obtained by a user at his arrival is not a sufficient indication about the quality of his communication because of the dynamics of arrivals/departures in the system. In order to obtain the utility, we modify the Markov chain in order to allow tracking mobiles during their connection time. For users of radio condition n connected to system s , only states where there is at least one user (n, s) are considered. The calculation is as follows:

- 1) Introduce absorbing states A_n^s corresponding to the departure of mobiles that have terminated their connections. Additional transitions are thus added between \mathbf{M} and A_n^s with rate equal to:

$$\tilde{q}_n^s(\mathbf{M}, A_n^s) = \mu \cdot \mathbb{I}_{M_n^s > 0} \quad (10)$$

The transitions to the neighboring states with one less user are then modified accordingly by subtracting μ from the original transition rates defined in equation (5):

$$\tilde{q}_n^s(\mathbf{M}, \mathcal{D}_n^s(\mathbf{M})|\mathbf{P}, f) = (M_n^s - 1) \cdot \mu \cdot \mathbb{I}_{M_n^s > 0} \quad (11)$$

The remaining transition rates remain equal to the original transitions:

$$\tilde{q}_n^s(\mathbf{M}, \mathcal{G}_{n'}^s(\mathbf{M})|\mathbf{P}, f) = q(\mathbf{M}, \mathcal{G}_{n'}^s(\mathbf{M})|\mathbf{P}, f), \quad \forall n', s'$$

and

$$\begin{aligned} \tilde{q}_n^s(\mathbf{M}, \mathcal{D}_{n'}^s(\mathbf{M})|\mathbf{P}, f) \\ = q(\mathbf{M}, \mathcal{D}_{n'}^s(\mathbf{M})|\mathbf{P}, f), \quad \forall (n', s') \neq (n, s) \end{aligned}$$

The transition rates for the modified chain are illustrated in Figure 4.

- 2) Define matrix $\tilde{\mathbf{Q}}_n^s$ of elements $\tilde{q}_n^s(\mathbf{M}, \mathbf{M}')$ defined above and with diagonal elements as in equation (6):

$$\tilde{q}_n^s(\mathbf{M}, \mathbf{M}|\mathbf{P}, f) = q(\mathbf{M}, \mathbf{M}|\mathbf{P}, f)$$

Knowing the load information function f and under policy \mathbf{P} , the volume of information $I_n^s(\mathbf{M}|\mathbf{P}, f)$ sent

by system s users subject to radio conditions n starting from state \mathbf{M} is then equal to the volume of information sent between state \mathbf{M} and the absorbing state A_n^s . Knowing that $I_n^s(A_n^s) = 0$, these values can be calculated by solving the set of linear equations for all states \mathbf{M} :

$$\sum \tilde{q}_n^s(\mathbf{M}, \mathbf{M}'|\mathbf{P}, f) \cdot I_n^s(\mathbf{M}'|\mathbf{P}, f) = -t_n^s(\mathbf{M}) \quad (12)$$

where $t_n^s(\mathbf{M})$ stands for the throughput and $\tilde{q}_n^s(\mathbf{M}, \mathbf{M}'|\mathbf{P}, f)$ is the transition rate between state \mathbf{M} and its neighboring state \mathbf{M}' obtained as described above (due to arrivals and departures). This calculation is based on the idea that the volume of information sent within state \mathbf{M} before any transition occurs is equal to the throughput ($t_n^s(\mathbf{M})$) multiplied by the time spent in \mathbf{M} (i.e., $-1/\tilde{q}_n^s(\mathbf{M}, \mathbf{M}|\mathbf{P}, f)$). Adding the information volume sent starting from \mathbf{M}' (i.e., $I_n^s(\mathbf{M}'|\mathbf{P}, f)$) and the probability to move first to \mathbf{M}' (i.e., $-\tilde{q}_n^s(\mathbf{M}, \mathbf{M}'|\mathbf{P}, f)/\tilde{q}_n^s(\mathbf{M}, \mathbf{M}|\mathbf{P}, f)$), we obtain the equation:

$$I_n^s(\mathbf{M}|\mathbf{P}, f) = \frac{-t_n^s(\mathbf{M})}{\tilde{q}_n^s(\mathbf{M}, \mathbf{M}|\mathbf{P}, f)} + \quad (13)$$

$$\sum_{\mathbf{M}' \neq \mathbf{M}} \frac{-\tilde{q}_n^s(\mathbf{M}, \mathbf{M}'|\mathbf{P}, f)}{\tilde{q}_n^s(\mathbf{M}, \mathbf{M}|\mathbf{P}, f)} I_n^s(\mathbf{M}'|\mathbf{P}, f)$$

which is exactly equation (12) after simple manipulations.

- 3) The utility of a class- n user that has found the network in state \mathbf{M} and chosen to connect to system s is the volume of information sent starting from state $\mathcal{G}_n^s(\mathbf{M})$. Recall that $\mathcal{G}_n^s(\mathbf{M})$ is defined as the state with one more class- n call connected to system s :

$$u_n^s(\mathbf{M}|\mathbf{P}, f) = I_n^s(\mathcal{G}_n^s(\mathbf{M})|\mathbf{P}, f) \quad (14)$$

Remark 1: Note that the column corresponding in $\tilde{\mathbf{Q}}$ to the absorbing, say i , has all entries (except to the one on the diagonal) equal to μ . Add μI_n^s to both sides of equation (12) and then proceed by eliminating the absorbing state in that

equation. We do so by deleting the i^{th} element in the vectors t and I in equation (12), and by deleting the i^{th} column and row of \tilde{q} . With some abuse of notation, we also use the notation that we had before in the case where the absorbing states are removed. We obtain in matrix notation:

$$\mu \mathbf{I}_n^s = \mathbf{t}_n^s - \mathbf{G}_n^s$$

where $\mathbf{G}_n^s = -\tilde{\mathbf{Q}}_n^s + \mu \mathbf{J}$ and \mathbf{J} is the identity matrix. Since we had added $\mu \mathbf{I}_n^s$ to both sides after deleting the i^{th} column from $\tilde{\mathbf{Q}}$, $-\mathbf{G}$ is a rate matrix (in particular all the entries on a row sum to zero). There is a unique solution \mathbf{W} to the above equation which is the *total discounted utility* with a discount factor of $\exp(-\mu)$, i.e.

$$W(m) = \int_0^\infty e^{-\mu t} E_{\mathbf{P}}[t_n^s(\mathbf{M})_t] dt$$

where \mathbf{M}_t is the state of the chain at time t and where m is its initial state at time 0, see e.g. [23, p 134]. Thus the total cost criterion is in fact equivalent to a discounted cost one.

C. What about elastic flows?

Till now, the analysis was limited to streaming flows that can only partially profit from the throughput offered by the network. This stands in contrast to the case of elastic flows. This work was motivated by the fact that future personal communication systems are supposed to support a variety of services, including elastic services (web browsing, e-mail, fax, file transfer, etc.). Indeed, when elastic flows are involved, the problem becomes different as users are able to profit from all the throughput that can be offered by the cell in order to finish faster their transfers; the service rate is thus state-dependent. The consequence of this is that utility is no more related to the volume of information sent during the communication time as the file size is independent from the achieved throughput. In a best effort network all users obtain best effort service, meaning that they obtain unspecified variable bit rate and delivery time, depending on the current traffic load. The utility is then related to the file transfer time calculated, as before, by modifying the state space and introducing absorbing states. The average file transfer time of a call with radio condition n that finds the system in state \mathbf{M} and connects to system s is equal to the hitting time ($h_n^s(\mathcal{G}_n^s(\mathbf{M}))$) between state $\mathcal{G}_n^s(\mathbf{M})$ and the absorbing state A_n^s .

1) *Steady-state probabilities*: First, the admissible state space is the same as in equation (3) if the constraint on the minimal throughput is kept in order to ensure a guaranteed QoS. Let the offered traffic of elastic calls with radio conditions n be Poisson of intensity λ_n and the file size be exponentially distributed with average size Z . Within \mathcal{F} , the transitions between neighboring states are due to arrivals and call terminations and the process describing the evolution of the number of calls is Markovian [24]. The transitions are as follows:

- An arrival of an elastic call with radio condition n will lead to a transition to state $\mathcal{G}_n^s(\mathbf{M})$ with rate

$$r(\mathbf{M}, \mathcal{G}_n^s(\mathbf{M})|\mathbf{P}, f) = \lambda_n \cdot \mathbb{I}_{P_{n,f}(\mathbf{M})=s} \cdot \mathbb{I}_{\mathcal{G}_n^s(\mathbf{M}) \in \mathcal{A}}$$

- A (n, s) call termination in state \mathbf{M} leads to a transition with rate:

$$r(\mathbf{M}, \mathcal{D}_n^s(\mathbf{M})|\mathbf{P}, f) = \frac{M_n^s}{Z} \frac{D_n^s G(\mathbf{M})}{\sum_{m=1}^N \sum_{r=1}^S M_m^r}$$

After defining the diagonal elements of the transition matrix \mathbf{R} as in equation (6), the steady state probabilities are obtained by solving $\mathbf{\Pi}(\mathbf{P}, f) \cdot \mathbf{R}(\mathbf{P}, f) = 0$, with $\mathbf{\Pi}(\mathbf{P}, f) \cdot \mathbf{e} = 1$.

2) *Utilities*: In order to obtain the utilities of system s calls subject to radio conditions n , the state space \mathcal{F} is modified and absorbing states A_n^s are introduced. The resolution is as follows:

- In states where there is at least one (n, s) user in the system, a transition is added toward the absorbing state A_n^s with rate:

$$\tilde{r}(\mathbf{M}, A_n^s|\mathbf{P}, f) = \frac{1}{Z} \frac{D_n^s \cdot G(\mathbf{M})}{\sum_{m=1}^N \sum_{r=1}^S M_m^r}$$

The original transition corresponding to the departure happens now with rate:

$$\tilde{r}(\mathbf{M}, \mathcal{D}_n^s(\mathbf{M})|\mathbf{P}, f) = \frac{M_n^s - 1}{Z} \frac{D_n^s \cdot G(\mathbf{M})}{\sum_{m=1}^N \sum_{r=1}^S M_m^r}$$

The other transition rates $\tilde{r}(\mathbf{M}, \mathbf{M}')$ are calculated similarly to those in the streaming case.

- The different hitting times are calculated by solving the set of linear equations, $\forall \mathbf{M} \in \mathcal{F}$ (see [25], theorem 3.3.3):

$$\sum \tilde{r}_n^s(\mathbf{M}, \mathbf{M}'|\mathbf{P}, f) \cdot h_n^s(\mathbf{M}'|\mathbf{P}, f) = -1 \quad (15)$$

- The average download time for a class- n user that have found the network in state \mathbf{M} and chosen to connect to system s is the hitting time between state $\mathcal{G}_n^s(\mathbf{M})$ and the absorbing state:

$$u_n^s(\mathbf{M}|\mathbf{P}, f) = h_n^s(\mathcal{G}_n^s(\mathbf{M})|\mathbf{P}, f) \quad (16)$$

D. Impact of mobility

As stated before, a mobile may be affected by some periods of degraded throughput due to its mobility or the mobility of other users within the cells, but this leads to QoS degradation rather than premature call termination (i.e., no dropping is considered).

1) *Markovian analysis*: When a users moves within the cell, its radio condition may change. If this latter degrades (the peak rate decreases), it may happen that the resources of the cell are no more sufficient to ensure the required QoS (T_{min}) for all users in the cell. The state space is thus enlarged by introducing states that are not admissible (any new user will not be admitted when the network is in one of these states), but can be visited due to mobility. The network can thus visit all the states such that the following conditions are verified:

$$\frac{\sum_{n=1}^N \sum_{s=1}^S M_n^s}{G(\mathbf{M})} \leq \frac{T_{min}}{D_N^s}, \forall s | \sum_{n=1}^N M_n^s > 0 \quad (17)$$

Here, the extreme case corresponds to the accumulation of all ongoing calls in the worst radio condition region N . Within

this new state space, in addition to the transitions stated in Section III-A2, the following events are to be added:

- Mobility of an ongoing connection of radio condition n . Let $\mathcal{H}_{n,n'}^{s,s'}(\mathbf{M})$ denote the state of the system if a mobility happens from a class (n, s) to class (n', s') . A transition with $s \neq s'$ corresponds to a vertical handover from system s to system s' and happens only if such a handover is allowed. Suppose that a user stays within region n for an exponential time of average $1/\nu_n$, and when he leaves this region, he moves to region n' with probability $p_{n,n'}$, the transition between states \mathbf{M} and $\mathcal{H}_{n,n'}^{s,s'}(\mathbf{M})$ happens with the following rate:

$$q(\mathbf{M}, \mathcal{H}_{n,n'}^{s,s'}(\mathbf{M}) | \mathbf{P}, f) = M_n^s \cdot \nu_n \cdot p_{n,n'} \quad (18)$$

Note that, following the decomposition of the cell into concentric rings, mobility happens only from zone n to zone $n \pm 1$. Geometric considerations as those in [11] lead to $p_{n,n+1} = \frac{d_{n+1}}{d_n + d_{n+1}}$.

- Handover of a call of class (N, s) to an adjacent cell. This happens with rate $M_N^s \cdot \nu_N \cdot p_{N,N+1}$ and leads to state $\mathcal{D}_N^s(\mathbf{M})$, as if it were a call termination.
- Arrival of a handover call from an adjacent cell to zone N . This happens with rate λ_{HO} and leads to state $\mathcal{G}_N^s(\mathbf{M})$ if the policy implies it (as if it were a new arrival).

Numerical resolution of the balance equations is still possible after adding these transitions.

2) *Handover rate calculation*: In equilibrium, the overall system may be assumed homogeneous. We can thus assume that the mean handover arrival rate to the given cell is equal to the mean handover departure rate from it. Focusing on the last ring, we have:

$$\lambda_{HO} = \sum_{\mathbf{M} \in \mathcal{A}} \sum_{s=1}^S M_N^s \cdot \nu_n \cdot p_{N,N+1} \cdot \pi(\mathbf{M} | \mathbf{P}, f) \quad (19)$$

Thereby, the handover rate and the steady state probabilities are inter-dependent. This leads to a fixed point calculation of λ_{HO} .

IV. GAME THEORETIC FRAMEWORK

In this section, we use the users' utilities we derived above to derive the association policies. We first search for the global optimum policy, i.e. the policy that maximizes the global utility of the network. Nevertheless, as it is not realistic to consider that the users will seek the global optimum, we show how to find the policy that corresponds to the Nash equilibrium³, knowing that users will try to maximize their individual utilities. We will next show, by means of a Stackelberg formulation, how the operator can control the equilibrium of its wireless users to maximize its own utility by sending appropriate load information.

³It is well-known that NE is generally inefficient in communication games [26], but it may not require explicit message exchanges, while global optimality can usually be achieved only by exchanging implicit or explicit coordination messages among the participating users.

A. Global optimum strategy

Cooperative approaches in communication theory usually focus on studying how users can jointly improve their performance when they cooperate. For example, the users may optimize a common objective function, which represents the optimal social welfare allocation rule based on which the system-wide resource allocation is performed. A profile of actions \mathbf{P} is said to be global optimum if no other policy profile gives every agent as much utility while giving at least one agent a higher utility. For our specific problem, the global utility function can be written as:

$$U(\mathbf{P}, f) = \sum_{n=1}^N \frac{\lambda_n + \lambda_{HO}}{\sum_{i=1}^N \lambda_i + \lambda_{HO}} \sum_{l \in \mathcal{L}} [(1 - b_n(l | \mathbf{P}, f)) \cdot (20)$$

$$\sum_{\mathbf{M} | f(\mathbf{M})=l} u_n^{P_{n,l}}(\mathbf{M} | \mathbf{P}, f) \pi(\mathbf{M} | \mathbf{P}, f)]$$

Note that, in this utility, we consider not only the QoS of accepted users (throughput for streaming users and transfer time for elastic users), but also the blocking rate as the aim is also to maximize the number of accepted users. We also weight the users of different radio conditions with their relative arrival rates. The global optimum policy is the one among all possible policy profiles that maximizes this utility:

$$\mathbf{P}^{GO} = \arg \max_{\mathbf{P}} U(\mathbf{P}, f) \quad (21)$$

It is worth mentioning that information exchanges among users is generally required to enable users to coordinate in order to achieve and sustain global efficient outcomes. In order to alleviate this hurdle, we turn to non-cooperative games.

B. Nash equilibrium strategy

There exist many systems where multiple independent users, or players, may strive to optimize their own utility or cost *unilaterally*, which can be regarded as non-cooperative games. In this context, users of different radio conditions are interested by maximizing their individual QoS given the load information broadcast by the network. The utility that a class n user might obtain if it chooses system s when the load information is l , while all other users follow policy profile \mathbf{P} is then:

$$U_{n,l}^s(\mathbf{P}, f) = \frac{\sum_{\mathbf{M} | f(\mathbf{M})=l} u_n^s(\mathbf{M} | \mathbf{P}, f) \pi(\mathbf{M} | \mathbf{P}, f)}{\sum_{\mathbf{M} | f(\mathbf{M})=l} \pi(\mathbf{M} | \mathbf{P}, f)} \quad (22)$$

A strategy profile $\mathbf{P}^{NE}, \forall n \in \mathcal{N}, \forall l \in \mathcal{L}$ corresponds to a Nash equilibrium (NE) if, for all radio conditions and all load informations, any unilateral switching to a different strategy can improve user's payoff. Mathematically, this can be expressed by the following inequality, given the load information function f , for all radio condition $n \in \mathcal{N}$ and all load information $l \in \mathcal{L}, \forall \sigma_{n,l} \neq P_{n,l}^{NE}$:

$$U_{n,l}^{P_{n,l}^{NE}}(\mathbf{P}^{NE}, f) \geq U_{n,l}^{\sigma_{n,l}}(\mathbf{P}^{NE}, f) \quad (23)$$

Two points are noteworthy here. First, Nash equilibria may be globally inefficient. Second, Nash equilibria need not exist in general within pure policies⁴ (the reason is that this set

⁴A pure policy is a function from the available information to the set of association actions.

is in non convex). We need therefore to extend the class of policies to one under which the achievable set of utilities is compact and convex. We may do that by using symmetric randomized stationary policies⁵. We shall assume throughout the following assumption: **A1**. Under any pure policy \mathbf{P} , the Markov chain whose transitions are $\mathbf{Q}(\mathbf{P}, f)$ is ergodic (i.e., from each state we can reach any other state within finite expected time). The following are well known implications of A1 [27], [28]:

Lemma 1: A1 implies the following

- The Markov chain is ergodic under any stationary randomized policy.
- $\pi(\mathbf{M}|\mathbf{P}, f)$ is uniformly bounded from below in all stationary randomized policies.
- π is continuous in \mathbf{P} and f

Theorem 1: Assume A1. There exists a Nash equilibrium within the set of symmetric stationary randomized policies.

Proof. Consider the game over the the class of randomized stationary policy \mathbf{P} . It follows from Lemma 1 that $U_{n,l}^s(\mathbf{P}, f)$ is continuous in \mathbf{P} and f . It is also seen to be *linear* in $u_{n,l}^s$. The set of stationary randomized policies is compact and convex. Combining all this and applying Kakutani's fixed point Theorem, we establish the existence of a stationary equilibrium policy.

C. Stackelberg equilibrium strategy

In the previous section, we derived the policy that corresponds to the Nash equilibrium for a game where players are the wireless users that aim at maximizing their payoff. However, there is another dimension of the problem related to the information sent by the network and corresponding to the different load information. Motivated by the fact that when selfish users choose their policies independently without any coordination mechanism, Nash equilibria may result in a network collapse, we propose a methodology that transforms the non-cooperative game into a Stackelberg game. Stackelberg equilibria of the Stackelberg game can overcome the deficiency of the Nash equilibria of the original game. Concretely, the network may guide users to an equilibrium that optimizes its own utility if it chooses the adequate information to send. At the core lies the idea that introducing a certain degree of hierarchy in non-cooperative games not only improves the individual efficiency of all the users but can also be a way of reaching a desired trade-off between the global network performance at the equilibrium and the requested amount of signaling. The proposed approach can be seen as intermediate scheme between the totally centralized policy and the non-cooperative policy. It is also quite relevant for flexible networks where the trend is to split the intelligence between the network infrastructure and the (generally mobile) users' equipments.

⁵We define the set of symmetric randomized stationary policies \mathfrak{R} by the set of probability measures over the set of pure policies (R). A symmetric randomized stationary policy \mathbf{P} has the interpretation that at each given information.

More formally, let \mathcal{C} be the finite set of all possible choices of the aggregating loads function f_j . The way of aggregating the loads in the broadcast information (expressed hereafter by the load information function f_j) is inherent to the previous analysis. In particular, the utilities of individual users, calculated in equation (22), is function of $f_j(\cdot)$:

$$U_{n,l}^s(\mathbf{P}, f_j) = \frac{\sum_{\mathbf{M}|f_j(\mathbf{M})=l} u_n^s(\mathbf{M}|\mathbf{P}, f_j) \pi(\mathbf{M}|\mathbf{P}, f_j)}{\sum_{\mathbf{M}|f_j(\mathbf{M})=l} \pi(\mathbf{M}|\mathbf{P}, f_j)}$$

We call the transformed game the Stackelberg game because the network manager chooses his strategy (by means of the load information function f_j) before the users make their decisions' policies. In this sense, the network manager can be thought of as a Stackelberg leader and the users as followers. The Stackelberg problem is thus defined as the maximization of the utility of the network by tuning the load information function $f_j(\cdot)$. Suppose that the aim of the operator is to maximize its revenues by maximizing the acceptance ratio, the Stackelberg equilibrium verifies:

$$f^{SE} = \arg \max_f \min_j b(\mathbf{P}^{NE}, f_j) \quad (24)$$

where \mathbf{P}^{NE} is the NE policy verifying (23) and the blocking $b(\cdot)$ is defined as in equation (9). This leads the wireless users to a Stackelberg equilibrium that depends on the way the network aggregates the load information. Notice that the users still behave non-cooperatively and maximize their payoffs, and the intervention of the manager affects their selfish behavior even though the manager does neither directly control their behavior nor continuously communicate with the users to convey coordination. As a result, this tends to substantially reduce signalling overhead.

V. PERFORMANCE RESULTS

For the sake of simplicity, we suppose that users are classified between users with good radio conditions (or cell center users) and users with bad radio conditions (or cell edge users). We will focus on the more realistic and cost effective case where the operator uses the same cell sites to deploy the new system (e.g. 3G LTE), while keeping the old ones (e.g. HSDPA). We consider joint admission control and vertical (inter-system) handover between HSDPA and LTE. The network sends aggregated load information as shown in Figure 2 with the following thresholds: $[L_1 = 0.3, L_2 = 0.7, H_1 = 0.3, H_2 = 0.7]$, meaning that a system is considered as highly loaded if its load exceeds 0.7 and as low-loaded if its load is below 0.3.

For comparison purposes, we study four different association approaches:

- *Global optimum approach:* obtained through an exhaustive search considering all possible strategy combinations in the vector profile $\mathbf{P} \in \mathcal{P}$. This will thus serve as the optimal social welfare solution for problem (21) in order to demonstrate just how much gain may theoretically be exploited through considering such a global optimal solution with respect to the other schemes.
- *Hybrid decision approach:* The proposed hybrid scheme where users receive aggregated load information and

maximize their individual utility. We illustrate the global utility corresponding to the Nash equilibrium strategy.

- *Peak rate maximization approach*: This is a simple association scheme where users do not have any information about the loads of the systems. They connect to the system s^{PR} offering them the best peak rate:

$$s^{PR} = \arg \max_s D_n^s \quad (25)$$

Note that this peak rate can be known by measuring the quality of the receiving signal.

- *Instantaneous rate maximization approach*: The network broadcasts M , the exact numbers of connected users of different radio conditions. Based on this information and on the measured signal strength, the wireless users estimate the throughput they will obtain in each system. Any new user with radio condition n will then connect to the system s^{IR} offering him the best throughput:

$$s^{IR} = \arg \max_s \frac{D_n^s}{1 + \sum_{m=1}^N \sum_{r=1}^S M_m^r} \quad (26)$$

Note that this scheme is not realistic as the network operator will not divulge the exact number of connected users in each system and each position of the cell.

A. Streaming flows

We first consider a streaming service where users require a minimal throughput of 1 Mbps and can profit from throughputs up to 2 Mbps in order to enhance video quality ($T_{min} = 1Mbps$ and $T_{max} = 2Mbps$). The mobility rate ν is taken such that $\frac{\nu}{\nu + \mu} = 30\%$ for a call duration of $1/\mu = 120$ seconds. We consider an offered traffic that varies such that the blocking rate remains below 1% and obtain numerically the Global-optimum and Nash equilibrium points. Figure 5 depicts the optimal policies for low and high traffic conditions. An important observation is that the policy chosen by cell edge users is different from that of cell center ones, as the throughputs they obtain are different: Cell edge users have a larger preference for LTE as their throughput in HSDPA is too low (see Figure 1). It is also shown that the optimal policy depends on the offered traffic: In a system with low traffic, it can be useful to connect to HSDPA even if it offers low peak throughputs as a throughput between 1 and 2 Mbps is sufficient. However, when the traffic increases, the number of simultaneous users sharing HSDPA capacity increases, and it is better for more users to connect to LTE. We illustrate in Figure 6 the correspondence between the utility and the load information for the hybrid decision approach. These curves give, for each load information l ($l = 1, \dots, 9$), the utilities of cell edge and cell center users that are connected to LTE and HSDPA. The utility is expressed in Mbits as users are interested in maximizing the information they send during their transfer time. The results are in concordance with those presented in Figure 5. For instance, when the load information index increases from 1 to 3, corresponding to a low HSDPA load and an increasing LTE load (see the load information function correspondence in Figure 2), users begin connecting to HSDPA instead of LTE. This is exactly what is illustrated in Figure 5. In particular, notice that in the edge cell, utility

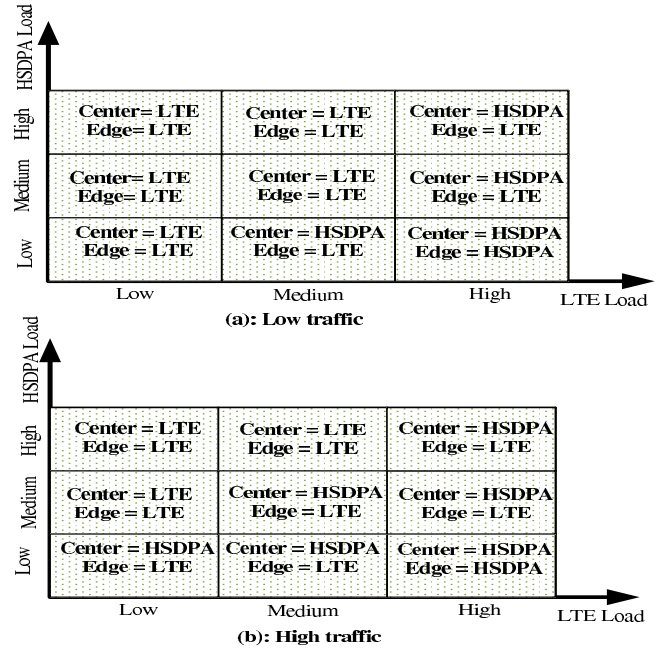

Fig. 5. Optimal policy as function of the offered traffic. This table indicates the optimal choice for cell center and cell edge users for different aggregated load conditions. *center = j* and *edge = i* indicates that cell center users choose to connect to system j while cell edge users connect to system i .

of HSDPA-edge users tends to become negligible as the load information increases from $l = 4$ to $l = 9$. As a consequence, cell edge users have a larger preference for LTE since their throughput in HSDPA is too low as shown in Figure 5.

Before moving to elastic flows, we plot in Figure 7 the global utility for the representative association approaches. As intuition would expect, the results show that the peak rate maximization approach presents the worst performance as the system that offers the largest peak throughput may be highly-loaded, resulting in a bad QoS. However, a surprising result is that the hybrid scheme, based on partial aggregated information, is comparable to the instantaneous rate maximization approach when traffic increases. This is due to the fact that streaming users will have relatively long sessions, visiting thus a large number of network states; knowing the instantaneous throughput at arrival will not bring complete information about the QoS during the rest of the connection (i.e., short term reward). In an opposite way, the proposed hybrid approach aims at maximizing the QoS during the whole connection time (i.e., long term reward). Notice that NE points do not exist for some values of offered traffic. In fact, although a non-cooperative game always has a mixed-strategy equilibrium, it may in general not have a pure-strategy equilibrium. However, we focus on pure-strategy Nash equilibria since they are arguably more natural and, when they exist, they may better predict game play. In particular, we see that hybrid approach results exhibit approximately 20 %, respectively 40 %, of global utility gain beyond peak rate maximization approach at 5 Erlang per cell, respectively at 10 Erlang per cell.

B. Elastic flows

We now consider accommodating elastic flows. We suppose that these flows correspond to FTP-like transfers of files of

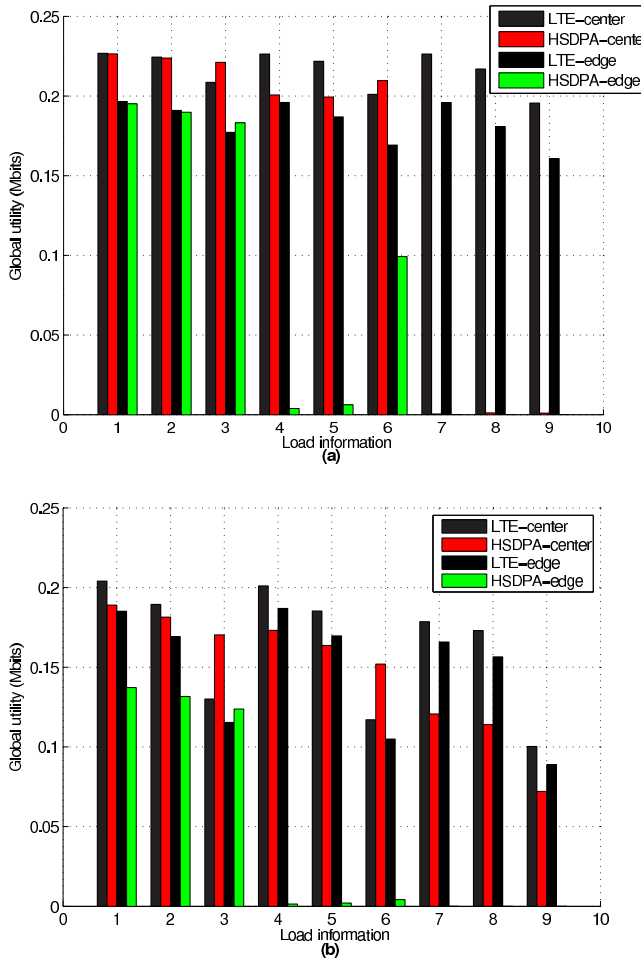

Fig. 6. Global utility as a function of the load information index in cell-center and center-edge in a network carrying streaming flows for low (a) and high traffic (b).

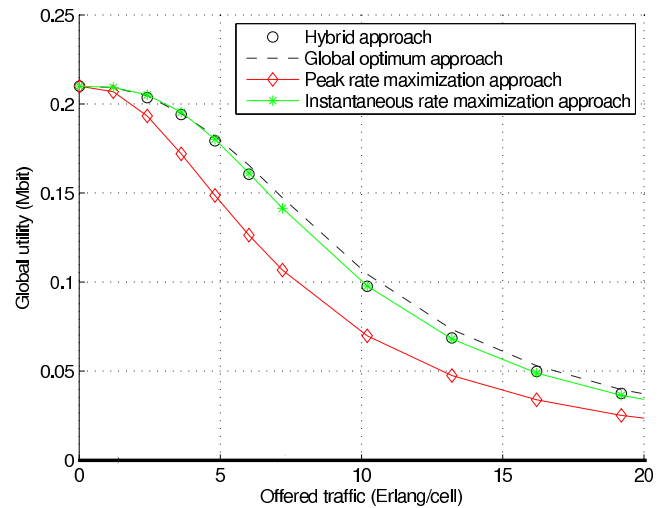

Fig. 7. Global utility in a network carrying streaming flows.

average size equal to $1Mbyte$. The main difference with streaming flows is that these calls can profit from all the available throughput in a best effort manner in order to download faster their file and leave the system. The loads of HSDPA and LTE systems for the four representative association approaches are illustrated in Figure 8. The impact of this Figure is twofold: (i) The hybrid approach exhibits inflexion points due to the user-system interaction since the aggregated optimal policy changes as the load in LTE and HSDPA varies. Users in the two other approaches choose to connect to LTE (since it offers the best throughput) and stay within it till it saturates, (ii) As elastic users can profit from all the available throughput, they prefer connecting to LTE when the traffic is low. However, when traffic increases, the capacity of LTE is shared by many users and some of them prefer connecting to HSDPA which will offer comparable throughputs. This will result in an inflexion point in the hybrid load curves. Another inflexion point is observed for high traffics when HSDPA becomes saturated and LTE is again the preferred system for almost everybody.

In a network carrying elastic flows, the global utility is expressed in sec^{-1} as users are interested in lowering their transfer times. We illustrate in Figure 9 this global utility for

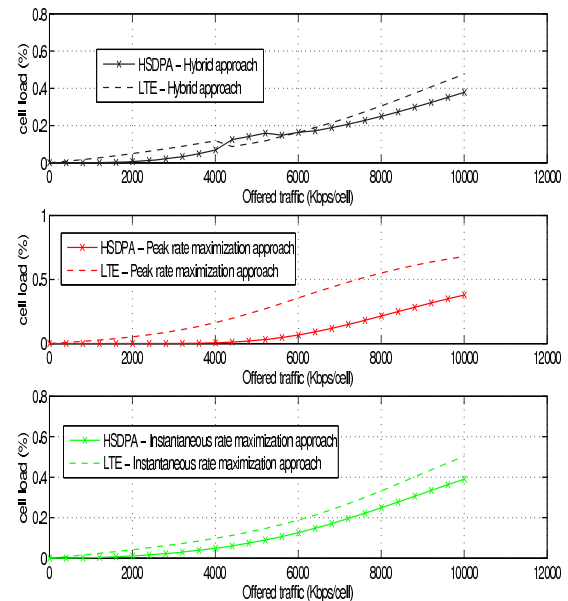

Fig. 8. System loads for increasing offered traffic: Elastic case.

the above-defined association approaches. We observe that, contrary to the streaming case, the hybrid approach significantly outperforms the two other approaches, and its advantage increases for high traffics. In particular, the proposed hybrid approach achieves almost 70%, respectively 85%, of global utility gain beyond instantaneous rate maximization approach at 2 Mbps/cell, respectively 10 Mbps/cell of traffic. This can be explained by the elasticity of calls: When the traffic goes large, the connections become longer and the wireless user visits more states during its transfer; the information at arrival becomes more and more obsolete.

The price of anarchy measures how good the system performance is when users play selfishly and reach the NE instead of playing to achieve the social optimum [29][30]. It is measured by computing the average on the incoming traffic of the ratio of the Nash equilibrium utility (when it exists) to the

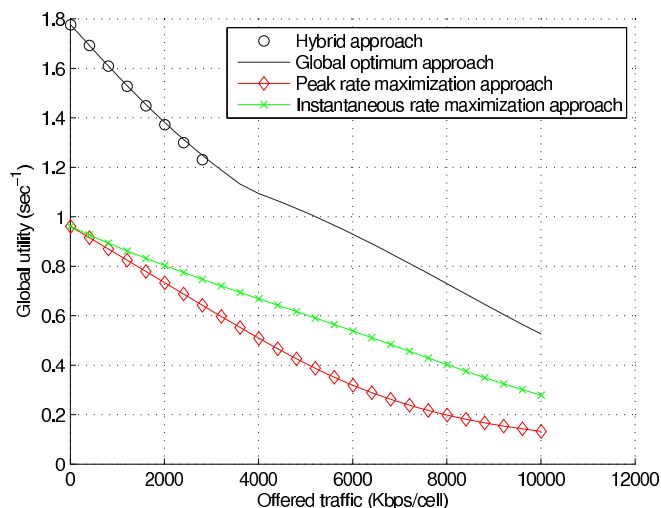

Fig. 9. Global utility in a network carrying elastic flows.

TABLE I
PRICE OF ANARCHY OF DIFFERENT CONFIGURATIONS

	Elastic service		Streaming service	
	without HO	with HO	without HO	with HO
Price of anarchy	99.75 %	98.13 %	99.55 %	98.42 %

corresponding socially optimal utility. From Table I, we may draw almost 1% efficiency loss for all configurations. Thus, in these cases, anarchy has no price. These price of anarchy results offer hope that such a robust and accurate modeling can be designed around competition, because selfish behavior does not arbitrarily degrade the mechanism's performance.

We now turn to the Stackelberg formulation of our problem, where the network tries to control the users' behavior by broadcasting appropriate information, expected to maximize its utility while individual users maximize their own utilities. We plot in Figure 10 the blocking rate for different ways of aggregating load information, obtained when users follow the policy corresponding to Nash equilibrium. In this figure, we plot the results for three cases: the optimal thresholds (in red circles) and two other sets of thresholds. We can observe that the utility of the network (expressed in the acceptance rate) can be substantially enhanced depending on the load information that is broadcasted. Such an accurate modeling of the Stackelberg problem is a key to understand the actual benefits brought by the proposed hybrid decision approach.

VI. CONCLUSION

In this paper, we studied a hybrid approach for radio resource management in heterogeneous cognitive networks in the presence of mobility. By hybrid we mean distributed decision making assisted by the network, where the wireless users aim at maximizing their own utility, guided by information broadcast by the network about the load of each system. We first showed how to derive the utilities of streaming and elastic flows that are related to the QoS they receive under

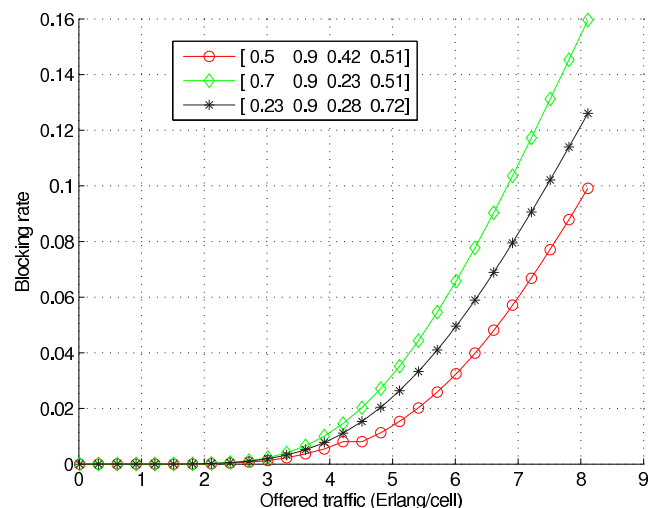
Fig. 10. Blocking rate for different broadcast load information; a vector of thresholds $[L_1, L_2, H_1, H_2]$ means that system s will be considered as highly loaded if its load exceeds s_2 and as low-loaded if its load is below s_1 ($s = L$ for LTE and H for HSDPA).

the different association policies. We then derived the policy that corresponds to the Nash equilibrium and global optimum. Finally, we showed by means of a Stackelberg formulation, how the operator, by sending appropriate information about the state of the network, can optimize its global utility while users maximize their individual utilities. The proposed hybrid decision approach for cognitive radio networks can reach a good trade-off between the global network performance at the equilibrium and the requested amount of signaling.

REFERENCES

- [1] 3GPP TS 36.300, "Evolved Universal Terrestrial Radio Access (E-UTRA) and Evolved Universal Terrestrial Radio Access Network (E-UTRAN), Overall description," INRIA, Stage 2 (Release 8), Sept. 2009.
- [2] J. Mitola, "Cognitive radio: An integrated agent architecture for software defined radio," Ph.D. dissertation, Stockholm, Sweden, 2000.
- [3] M. Haddad, A. Hayar, and M. Debbah, "Spectral efficiency for spectrum pooling systems," *the IET Special Issue on Cognitive Spectrum Access*, vol. 2, no. 6, pp. 733–741, July 2008.
- [4] IEEE Standards Coordinating Committee 41 (Dynamic Spectrum Access Networks). [Online]. Available: <http://grouper.ieee.org/groups/scc41>.
- [5] S. Buljore, M. Muck, P. Martigne, P. Houze, H. Harada, K. Ishizu, O. Holland, A. Mikhailovic, K. A. Tsagkariss, O. Sallent, M. S. G. Clemo, V. Ivanov, K. Nolte, and M. Stamatelos, "Introduction to IEEE p1900.4 activities," *IEICE Transactions on Communications*, vol. E91-B, no. 1, 2008.
- [6] D. Fudenberg and J. Tirole, *Game Theory*. MIT Press, 1991.
- [7] E. Altman, T. Boulogne, R. Azouzi, and T. Jimenez, "A survey on networking games in telecommunications," *Computers and Operations Research*, vol. 33, no. 2, Feb. 2006.
- [8] M. Felegyhazi and J. Hubaux, "Game theory in wireless networks: A tutorial," *EPFL technical report, LCA-REPORT-2006-002*, Feb. 2006.
- [9] E. Stevens-Navarro, Y. Lin, and V. W. S. Wong, "An mdp-based vertical handoff decision algorithm for heterogeneous wireless networks," *IEEE Trans. Veh. Technol.*, vol. 57, no. 2, pp. 1243–1254, 2008.
- [10] D. Kumar, E. Altman, and J.-M. Kelif, "Globally optimal user-network association in an 802.11 wlan and 3g umts hybrid cell," in *Proc. 20th International Teletraffic Congress (ITC 20)*, Ottawa, Canada, June 2007.
- [11] S. Horrich, S.-E. Elayoubi, and S. B. Jemaa, "On the impact of mobility and joint rrm policies on a cooperative wimax/hdsdpa network," in *IEEE WCNC*, Las Vegas, USA, April 2008.
- [12] B. Kauffmann, F. Baccelli, F. Chaintreau, V. Mhatre, K. Papagiannaki, and C. Diot, "Measurement-based self organization of interfering 802.11 wireless access networks," in *IEEE INFOCOM*, 2007.

- [13] Y. Bejerano, S.-J. Han, and L. E. Li, "Fairness and load balancing in wireless lans using association control," in *ACM MobiCom*, 2004.
- [14] P. C. D.J. Leith, "A self-managed distributed channel selection algorithm for wlangs," *Modeling and Optimization in Mobile, Ad Hoc and Wireless Networks*, April 2006.
- [15] E. Ozgur, "Association games in ieee 802.11 wireless local area networks," *IEEE Trans. Wireless Commun.*, vol. 7, no. 12, pp. 5136–5143, 2008.
- [16] S. Shakkottai, E. Altman, and A. Kumar, "Multihoming of users to access points in wlangs: A population game perspective," *IEEE J. Sel. Areas Commun.*, vol. 25, no. 6, August 2007.
- [17] —, "The case for non-cooperative multihoming of users to access points in ieee 802.11 wlangs," in *IEEE Infocom*, 2006.
- [18] L. Jiang, S. Parekh, and J. C. Walrand, "Base station association game in multi-cell wireless networks," in *IEEE WCNC*, 2008.
- [19] D. Kumar, E. Altman, and J.-M. Kelif, "User-network association in an 802.11 wlan & 3g umts hybrid cell: Individual optimality," in *Proc. IEEE Sarnoff Symposium*, Princeton, USA, April 2007.
- [20] P. Coucheny, C. Touati, and B. Gaujal, "Fair and efficient user-network association algorithm for multi-technology wireless networks," in *Proc. 28th conference on Computer Communications miniconference (INFOCOM)*, 2009.
- [21] G. Hardin, "The tragedy of the commons," *Science*, 1968.
- [22] S. E. Elayoubi, E. Altman, M. Haddad, and Z. Altman, "A hybrid decision approach for the association problem in heterogeneous networks," in *IEEE Conference on Computer Communications (INFOCOM)*, San Diego, USA, March 2010.
- [23] W. Fleming and H. Soner, "Controlled markov processes and viscosity solutions," *Springer Verlag*, 2006.
- [24] E. Altman, D. Artiges, and K. Traore, "On the integration of best-effort and guaranteed performance services," *European Transactions on Telecommunications. Special Issue on Architectures, Protocols and Quality of Service for the Internet of the Future*, no. 2, February-March 1999.
- [25] J. Norris, "Markov chains," *Cambridge Series in Statistical and Probabilistic Mathematics*, 1998.
- [26] P. Dubey, "Inefficiency of nash equilibria," *Mathematics of Operations Research*, vol. 11, no. 1, pp. 1–8, February 1986.
- [27] L. Kallenberg, "Linear programming and finite markovian control problems," *Mathematisch Centrum*, 1983.
- [28] E. Altman, "Constrained markov decision processes," *Chapman and Hall/CRC*, 1999.
- [29] T. Roughgarden and E. Tardos, "How bad is selfish routing?" *J. ACM*, vol. 49, no. 2, pp. 236–259, 2002.
- [30] R. Johari and J. N. Tsitsiklis, "Efficiency loss in a network resource allocation game," *Math. Oper. Res.*, vol. 29, no. 3, pp. 407–435, 2004.



Salah Eddine Elayoubi received the engineering diploma in telecommunications and computer science from the Lebanese University at Tripoli, Lebanon, in 2000 and the Master's degree in telecommunications and networking from the National Polytechnic Institute at Toulouse, France, in 2001. He completed his Ph.D. degree in Computer science and telecommunications at the University of Paris VI in 2004. Since then, he has been working in Orange Labs, the research and development division of the France Telecom group. His research interests include radio resource management, performance evaluation and dimensioning of mobile networks.



Eitan Altman received the B.Sc. degree in electrical engineering (1984), the B.A. degree in physics (1984) and the Ph.D. degree in electrical engineering (1990), all from the Technion-Israel Institute, Haifa. In (1990) he further received his B.Mus. degree in music composition in Tel-Aviv University. Since 1990, he has been with INRIA (National research institute in informatics and control) in Sophia-Antipolis, France. His current research interests include performance evaluation and control of telecommunication networks and in particular congestion control, wireless communications and networking games. He is in the editorial board of several scientific journals: JEDC, COMNET, DEDS and WICON. He has been the (co)chairman of the program committee of several international conferences and workshops on game theory, networking games and mobile networks.



Zwi Altman received the B.Sc. and M.Sc. degrees in electrical engineering from the Technion-Israel Institute of Technology, in 1986 and 1989, and the Ph.D. degree in electronics from the INPT France in 1994. He was a Laureate of the Lavoisier scholarship of the French Foreign Ministry in 1994, and from 1994 to 1996 he was a Post-Doctoral Research Fellow in the University of Illinois at Urbana Champaign. In 1996 he joined France Telecom R&D where he has been involved in different projects related to network engineering, including radio resource management, automatic cell planning and self-organizing networks. In 2004, he co-received the France Telecom Innovation Prize, and in 2005 the IEEE Wheeler Award. From 2005 to 2007 Dr. Altman was the coordinator of the Eureka Celtic Gandalf project "Monitoring and Self-Tuning of RRM Parameters in a Multi-System Network" that received the Celtic Excellence Award.



Majed Haddad received his Electrical Engineering diploma in 2004 from the National Engineering School of Tunis (ENIT), Tunisia. He received the Master degree from the University of Nice Sophia-Antipolis in France in 2005, and a doctorate in Electrical Engineering from Eurecom Institute in 2008. In 2009, he joined France Telecom R&D as a Post-Doctoral Research Fellow. Dr. Haddad is currently pursuing his postdoctoral research at INRIA Sophia Antipolis in France where his research interests included advanced design of PHY/MAC

layer of wireless communication systems with particular attention on Quality of Experience (QoE) for mobile streaming services.