

A Hybrid Power-Saving Protocol by Dual-Channel and Dual-Transmission-Range Clustering in IEEE 802.11 MANETs*

Jehn-Ruey Jiang, Chau-Yuan Yang and Ting-Yao Chiou
Department of Computer Science and Information Engineering
National Central University
Jhongli City, Twain, R. O. C.

Abstract

There are two types of power saving protocols for IEEE 802.11-based MANETs: synchronous and asynchronous. IEEE 802.11 has defined a synchronous power-saving (PS) protocol for single-hop (full connected) MANETs based on periodical transmission of beacons by accurate clock synchronization. There are some quorum-based asynchronous PS protocols proposed. The protocols need no synchronized clocks; however, they usually consume more energy than the synchronous ones. In this paper, we proposed a hybrid PS protocol, which combines the advantages of synchronous and asynchronous ones for an IEEE 802.11 MANETs. The protocol utilizes the concept of dual channel and dual transmission-range clustering. It divides all the hosts into clusters. Each cluster has a head and all the heads are organized as a virtual backbone to help route data. The synchronous PS protocol can be operated in an individual cluster, and the quorum-based asynchronous PS protocol is applied among cluster heads. As we will show the proposed protocol is power efficient, scalable and adaptive to topology changing.

1. Introduction

The mobile ad hoc network (MANET) has attracted a lot of attention recently. A MANET consists of a set of mobile hosts, and does not have the support of any base station. Hosts have unpredictable mobility and can communicate with each other by sending messages either over a direct wireless link, or over a sequence of wireless links including one or more intermediate hosts. Applications of MANETs include battlefield communications, disaster rescue operations, outdoor activities, and so on.

Power saving is a critical issue for portable devices supported by batteries. This is because battery power is a limited resource, and battery technology is not likely to progress as fast as computing and communication technologies do. How to save the energy consumption in a MANET, in which devices¹ are all supported by batteries, has been intensively studied recently (e.g., power control is studied in [2,10], power-aware routing in [7,8], and low-power mode management in [1,4]).

There are two types of power-saving (PS) protocols for IEEE 802.11-based MANETs: synchronous and asynchronous ones. IEEE 802.11 [5] has defined its own protocol for single hop (full connected) MANETs based on periodical transmission of beacons. The protocol requires accurate clock synchronization and is classified as the synchronous protocol. Such a protocol is only suitable for one-hop environments since clock synchronization for multi-hop networks is costly and even impossible [9]. On the other hand, the paper [9] proposed asynchronous PS protocols which need not to synchronize host clocks. The paper [3] further correlates the power saving protocol to the quorum system concept for saving more energy. It shows that any quorum system satisfying the rotation closure property can be translated to an asynchronous PS protocol for IEEE 802.11 MANETs. Although the asynchronous protocols do not need to synchronize all hosts, they usually consume more energy than the synchronous one.

In this paper, we propose a hybrid power saving protocol, which combines the advantages of synchronous and asynchronous ones. According to the protocol, all the hosts are divided into several clusters. Each cluster has one cluster head with other being cluster members. Members are one-hop neighbors of the head and are synchronous with it. The IEEE 802.11

*This work is sponsored by NSC of Taiwan under grant-number NSC93-2213-E008-046

synchronous PS protocol is operated within an individual cluster. And the quorum-based asynchronous PS protocol proposed in [3] is applied among cluster heads. All the cluster heads are organized as a virtual backbone to help route data. We perform simulations and compare the protocol with the quorum-based asynchronous one. We find that the proposed protocol is the more power efficient and more scalable one.

The contributions of the paper are four-fold. First, it utilizes the clustering concept to design a hybrid PS protocol taking advantages of synchronous and asynchronous PS protocols. Second, it adopts dual transmission-range concept to eliminate the need of selecting gateway for relaying inter-cluster messages. Third, it adopts dual-channel concept to allow simultaneous transmissions of inter-cluster and intra-cluster messages, which increase throughput and make easy cluster maintenance. And fourth, it uses the cluster head exeunt mechanism to void the ever-increasing of cluster heads and to make the protocol adaptive to topology changing.

The rest of the paper is organized as follows. Preliminaries are given in Section 2. Section 3 introduces the proposed protocol. Simulation results are presented in Section 4. Conclusions are drawn in Section 5.

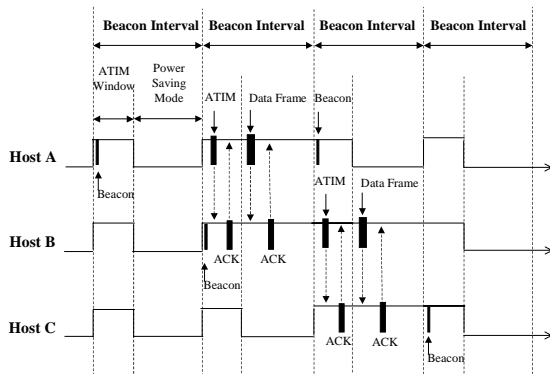

Figure 1: Transmission scenarios for PS hosts in a single-hop 802.11 MANET.

2. Preliminaries

IEEE 802.11 supports two power modes: active and power-saving (PS). Under the PS mode, a host can reduce its radio activity by only monitoring some periodical signals (such as beacons) in the network. Tuning a host to the PS mode can save a lot of energy.

For example, for an ORiNOCO IEEE 802.11b PC GoldCard, the power consumption is 1400mW, 950mW and 805mW when it remain active to transmit, receive, and monitor data packets, respectively. When the card switches to PS mode, the power consumption can be reduced to 60mW.

Under the ad hoc mode, IEEE 802.11 divides the time axis into equal-length beacon intervals, each of which starts with an ATIM (Ad hoc Traffic Indication Map) window. The ATIM window is relatively small compared to the beacon interval. PS hosts must remain active during the ATIM window so as to be notified by those intending senders, and may go to doze in the rest of the beacon interval if no one intends to send packets to it (refer to Fig. 1).

The power saving protocol of IEEE 802.11 only considers single-hop MANETs. It is classified as a *synchronous* protocol. On the other hand, the papers [9] and [3] propose several *asynchronous* power saving protocols, which are suitable for multi-hop MANETs. Among them, quorum-based ones are most promising because they send the least number of beacons. According such protocols, the time axis is divided evenly into beacon intervals, which are classified into two types (refer to Fig. 2): (1) Quorum interval: Its starts with a beacon window followed by a MTIM window. After the MTIM window, the host remains active (in monitor mode) for the rest of the beacon interval. (2) Non-quorum interval: It starts with a MTIM window. After the MTIM window, the host may go to the PS mode if it has no packets to send or receive.

Similar to IEEE 802.11, the beacon window is for hosts to compete sending their beacons. The MTIM window is similar to the ATIM window--- a host with buffered packets can compete to send notifications to intended receivers in the PS mode to wake them up. It is named so to reflect that it is used for multi-hop ad hoc networks.

In [9], it is proposed to group every n consecutive intervals, which is called a *round* later and to use the grid quorum system for a host to select quorum intervals. In [3], it is proposed to use a quorum system satisfying the rotation closure property for the selection. A quorum system is a collection of sets, called *quorums*, such that the intersection of any two quorums is always non-empty. The paper [3] shows that the finite projective plan (FPP), the grid, the torus, and the cyclic quorum systems satisfy the rotation closure property. Thus, all the quorum systems can be used for quorum interval selection. The papers [9, 3] show that no matter how asynchronous hosts' clocks are, two neighboring hosts can hear each other's beacon at least once in

every n consecutive beacon intervals. By embedding clock information in beacon frames, a host can figure out others' wake-up time so that it can initiate a data transmission at the proper time when the receiver turns on its radio.

Among asynchronous PS protocols, the quorum-based one may have the lowest active ratio, the ratio of time for a host turning on its radio. Still, we have the following two observations for the quorum-based asynchronous PS protocol: (1) Its active ratio can be as low as 0.34 (for FPP quorum system with 13 beacon intervals being a group), which is still much greater than 0.1 of the synchronous PS protocol. (2) A high node density has negative impact on the protocol. It causes high broadcast traffic and short system life time.

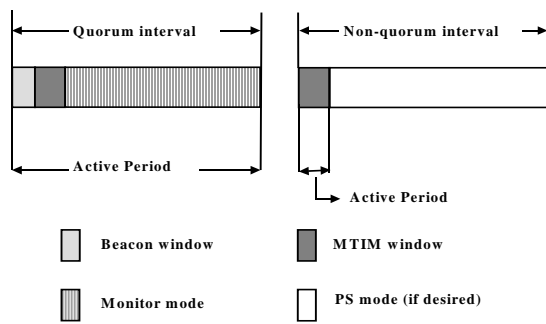

Figure 2: Structures of quorum intervals and non-quorum intervals.

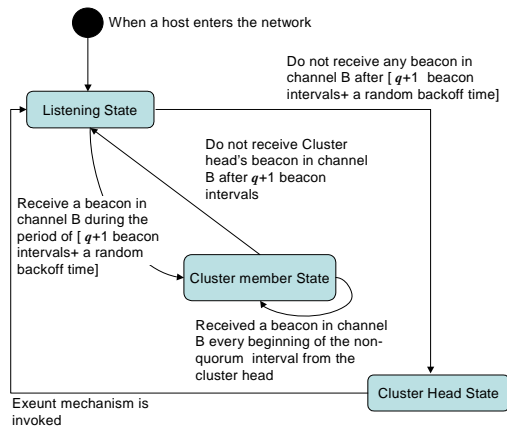

Figure 3: The state transition diagram for hosts.

3. The Proposed Protocol

In this section, we propose a protocol to respond to the observations of the quorum-based asynchronous PS protocol. Below, we first show the overview of the

proposed protocol.

3.1. Overview

The basic idea of the proposed protocol is to integrate the synchronous and asynchronous power saving protocols for IEEE 802.11-based MANETs to save more energy and to accommodate more hosts. The synchronous PS protocol has lower active ratio but is not suitable for multi-hop MANETs, while asynchronous protocols have opposite conditions. So we try to combine the advantages of synchronous and asynchronous PS protocols in our proposed one. The protocol divides all the hosts into clusters, in which one host is selected as the head with others being the members. The synchronous PS protocol is operated within individual cluster and the quorum-based asynchronous PS protocol is operated among cluster heads. To cope with the changing of network's topology, the clustering mechanism must be performed as quickly as possible. The protocol does not rely on location information and allow each host to decide to become a cluster head on the basis of neighborhood information. Each host can switch between two different communication ranges: normal and half and switch between two non-interfering communication channels A and B. The cluster head uses channel A with normal transmission range to communicate with other cluster heads, and uses channel B with half transmission range to communicate with its cluster members. A host will go through a lot of states as depicted in Fig. 3. We will elaborate the details of state transitions below.

3.2. Clustering Mechanism

When a host powers on, it will enter the listening state and will keep listening to beacons for $[(q+1)$ beacon intervals + random backoff time], where q is the number of quorum interval in a round. Only cluster heads send beacons. If the host hears a beacon from a host h , it will enter the cluster member state and join h 's cluster as a cluster member, and copies the clock and quorum settings from h . Otherwise it sets itself a new cluster head; it enters the cluster head state and starts to send beacons. It is noted that we add a random backoff time to reduce the possibility that neighboring nodes become heads simultaneously.

A host as a cluster member will keep monitoring the cluster head's beacon periodically to judge whether the cluster head still exists or not (the cluster head may move away or power off). If a cluster member does not receive any beacon from the head for $q+1$ beacon intervals, it assumes the head no more exists. The cluster member enters the listening state to join another cluster or become a new cluster head. Accordingly, all

the hosts will be divided into clusters; some of them are cluster heads and others are cluster members.

Because the hosts can move at random, cluster heads may gather together. When two or more cluster heads are too close, we can dismiss some of them from the duty of being heads. Each cluster head is assigned a total ordering priority, a triplet of (the duration of being the cluster head, the remaining power, the node ID). The triplet is embedded in the beacon. When a cluster head hears beacons from another host, it would estimate the distance between itself and the host by the signal strength received. If the distance is smaller than a threshold, it will check the priority and determine to exeunt or not. The distance threshold is adjustable; a larger threshold results in a smaller number of cluster heads but makes higher the variation of cluster heads, which is baneful to routing. We assume the threshold is 1/10 of normal transmission range in the following context.

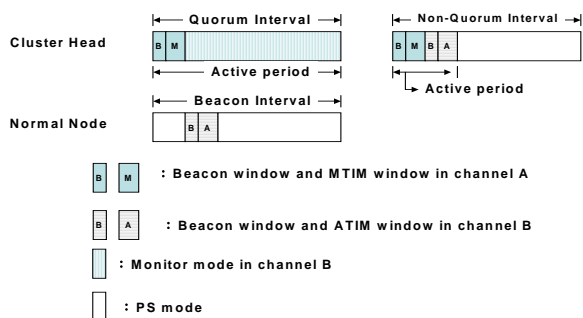

Figure 4: Structures of beacon intervals for cluster heads and cluster members.

3.3. Structure of Beacon Intervals

The structures of beacon intervals of the cluster head and cluster members are different (refer to Fig. 4). The cluster head runs the quorum-based asynchronous power saving protocol as proposed in [3], and the beacon intervals are also classified into two types:

(1) Quorum interval: In quorum interval, cluster head uses the channel A and the normal transmission rang to communicate with other cluster heads. The quorum interval starts with a beacon window followed by a MTIM window. After the MTIM window, the cluster head remains active (in monitor mode) for the remaining of the beacon interval.

(2) Non-quorum interval: Non-quorum interval starts with a beacon window followed by a MTIM window in channel A. It then comes a beacon window and an ATIM window in channel B. After those windows, the cluster head may go to the PS mode if it has no packets to send or receive. It is noted that in beacon window

and ATIM window of channel B, the cluster head adjust its transmission range to be half of the normal transmission range.

The beacon interval of a cluster member starts with a beacon window followed by an ATIM window in channel B. After the ATIM window, the cluster member may go to the PS mode if it has no packets to send or receive. The cluster member uses the channel B with half transmission range to communicate with the cluster head.

3.4. Synchronous PS within a Cluster

By our protocol, each cluster member is a one-hop neighbor of the associated cluster head. So, we can run the synchronous PS protocol within an individual cluster. The cluster members can only communicate with cluster head directly. After joining a cluster, a cluster member copies the clock and the quorum settings of the cluster head. Thus, it is easy to predict when the cluster head will enter the beacon window and of the non-quorum interval. Each cluster member wakes up at proper time accordingly and uses channel B to monitor the beacons sent from the cluster head. The cluster member maintains a counter recording the number of times of not hearing the beacons. The counter is reset to zero if the cluster member can hear the beacon. Once the counter is greater than $q+1$ (q is the number of quorum intervals in a round), the cluster member assumes that the head is absent and enter the listening state for joining a new cluster or becoming a new cluster head.

3.5. Virtual Backbone and Routing

We can treat the set of cluster heads as a virtual backbone through which the data are routed. Below, we take well-know AODV (Ad hoc On-Demand Distance Vector) protocol [6] as the routing protocol to illustrate how the virtual backbone helps route data. The source and the destination hosts can be a cluster head or a cluster member. If the source host is a cluster member, it sends the rout-request message to the cluster head in non-quorum interval first. Then the cluster head will broadcast the message to the cluster members in the next non-quorum interval. If the destination is in the cluster, it will reply a route-reply message to the cluster head at a hop count limit is encountered. If no route-reply message is received from cluster members immediately, the cluster head will rebroadcast the route-request message to neighboring cluster heads. The route-request message rebroadcast will continue until the request reaches the destination host. Afterward, the route-reply message will trace back to the source

host and the source host can start to send the data. Since the route-request message rebroadcast only occurs among cluster heads, the number of rebroadcasts is reduced dramatically, leading to large energy-saving.

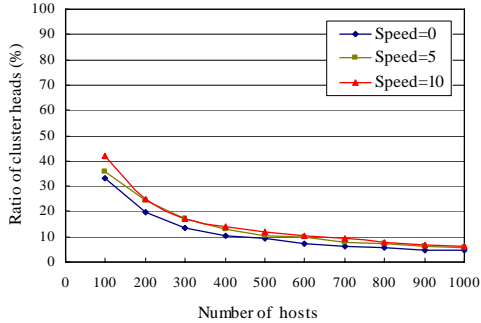

Figure 5: The ratio of cluster heads for different speeds and host densities. (number of hosts = 100 ~ 1000, mobility = 0 ~ 10m/sec)

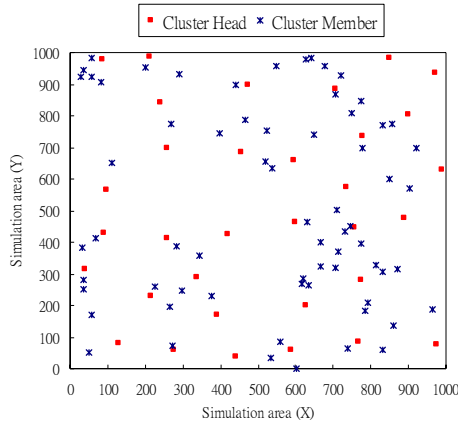

Figure 6 (a): Distribution of cluster heads. (100 hosts in a 1000m x 1000m area)

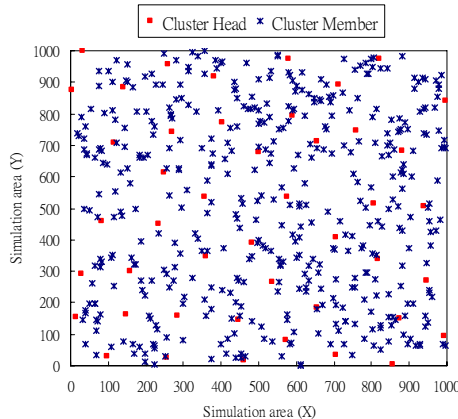

Figure 6 (b): Distribution of cluster heads. (500 hosts in a 1000m x 1000m area)

4. Simulation Results

In this section, we compare the proposed hybrid PS (HPS) protocol with the quorum-based asynchronous PS (QAPS) protocol [3] through a simulator written in C. An area of size 1000m x 1000m is simulated. Each host has a transmission rate of 2M bits/sec, a transmission radius of 250 meters, and initial battery energy of 100 Joules. The MAC part basically follows the IEEE 802.11 standard [5], except the power management part. Routes with random sources/destinations are generated, and the AODV (ad-hoc on-demand distance vector) routing protocol is adopted.

Three parameters are tunable in our simulations:

- **Mobility:** Host mobility follows the random way-point model, with pause time of 20 seconds. When moving, a host's speed can range in 0 ~ 8 m/sec.
- **Traffic load:** Routes are generated by a Poisson distribution with rates between 1 ~ 4 routes/sec. For each route, 20 packets, each of size 1K bytes, are sent.
- **Number of hosts:** The total number of mobile hosts in the MANET is 100 ~ 1000 hosts.

Three performance metrics are measured in the simulations:

- **The ratio of cluster heads.**
- **Survival ratio:** the number of surviving hosts (with non-zero energy) over the total number of hosts.
- **Throughput:** the average number of MAC-layer data packets successfully received in the network per second.

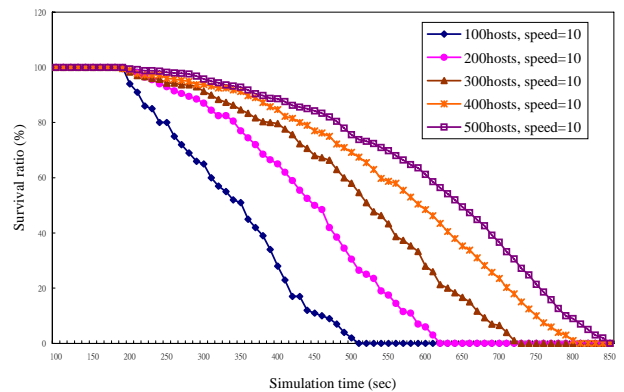

Figure 7: Survival ratios of the proposed protocol for different numbers of hosts. (number of hosts = 100 ~ 500, mobility = 10m/sec)

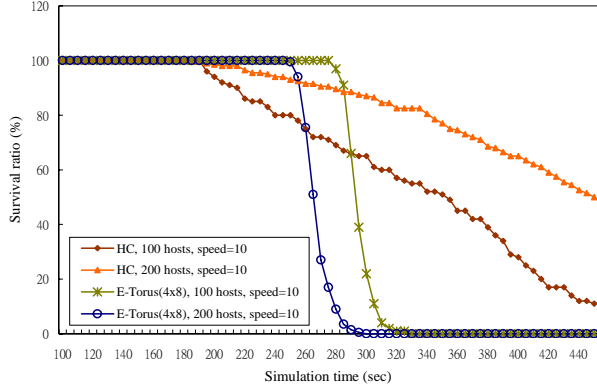

Figure 8: Survival ratios of the proposed protocol (HPS) and quorum-based asynchronous PS (QAPS) protocol (using the torus(4x8) quorum system). (100 hosts, mobility = 10m/sec)

A host can go to the PS mode when it does not serve as a source, a destination, or a relay host of any route. A broadcast message (such as the route request message) may need to be sent multiple times if the sending host finds that some of its neighbors are in the PS mode [3]. This is necessary because these PS hosts may wake up at different times and we need multiple transmissions to cover all of them. However, once a route is established (via the notification of a route reply message), all hosts in the route have to tune to the active mode.

Below, we show how mobility and host density affect the performance of the proposed PS protocols. Fig. 5 shows the ratio of the number of cluster heads over the total number of hosts for different speeds and different host densities. From this figure we know that when the speed increases, the ratio of cluster heads increases slightly. However, the ratio of cluster heads is decreasing when host density increase. The ratio of cluster heads affects the consumption of power since higher cluster head ratio indicates more power consumption. Thus, our protocol is expected to have better performance in high host density environment. Fig. 6 (a) and Fig. 6 (b) illustrate the distribution of cluster heads. We can see that cluster heads are evenly distributed over the whole area.

Fig. 7 shows the survival ratios of the proposed protocol for different numbers of hosts. We have observed that: a higher degree of mobility will lead to a worse survival ratio. As shown in Fig. 8, however, our protocol outperforms the QAPS protocol in terms of the survival ratio. In these two figures, the curves of the proposed protocol are stair-wise. The stair-wise shapes are caused by the simultaneous death (running

out of energy) of some cluster heads that are elected as the heads almost at the same time. In the proposed protocol, cluster heads have much more loads than cluster members, and thus run out of the limited power soon. When the MANET bootstraps, some of the hosts are elected as cluster heads almost at the same time. And afterward, the simultaneous death of cluster heads proceeds repeatedly. And this is the cause of stair-wise survival ratios.

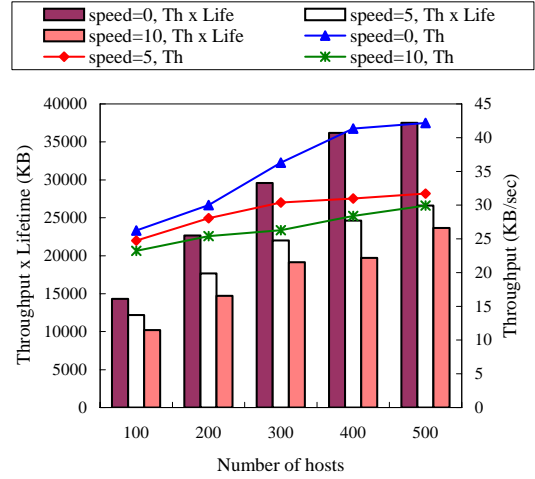

Figure 9: Throughput and throughput x lifetime of the proposed protocol for different speeds and host densities. (number of hosts = 100 ~ 500, mobility = 0 ~ 10m/sec)

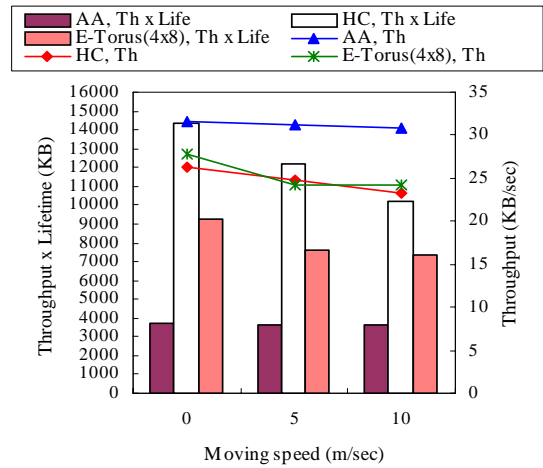

Figure 10: The comparison of the proposed protocol (HPS), the quorum-based asynchronous PS (QAPS) protocol (using torus(4x8) quorum system) and the non-power-saving (AA, always active) protocol in terms of throughput and throughput x lifetime. (100 hosts, mobility = 10m/sec)

Fig. 9 shows the impact of mobility on throughput and aggregate throughput (throughput×lifetime) for the proposed protocol. We observe that mobility has a negative impact on both metrics because more retransmissions are incurred as hosts move faster. However, as shown in Fig. 10, the proposed protocol is better than the QAPS protocol in both metrics. For the comparison sake, we also show the performance of the non-power saving protocol, which is denoted as AA (always active) protocol. The throughput of the AA protocol is the best since all the hosts running the protocol always turn their radio on. However, the AA protocol is far worse than the proposed protocol in terms of aggregate throughput. This is because the proposed protocol has much longer system lifetime than the AA protocol.

5. Conclusion

In this paper, we have proposed a hybrid PS protocol for an IEEE 802.11-based MANET to take advantages of both the synchronous and the asynchronous PS protocols to save more energy and to accommodate more hosts. The protocol utilizes the concept of dual channel and dual transmission-range clustering. It divides all the hosts into clusters. Each cluster has a cluster head and all the heads are organized as a virtual backbone to help route data. The synchronous PS protocol can be operated in an individual cluster, and the quorum-based asynchronous PS protocol is applied among cluster heads. The proposed protocol also uses the cluster head exeunt mechanism to void the ever-increasing of cluster heads, and is thus adaptive to topology changing. We have shown by simulation that the proposed protocol is more power efficient and more scalable than its counterpart – the quorum-based asynchronous power-saving protocol proposed in [3].

References

[1] B. Chen, K. Jamieson, H. Balakrishnan, and R. Morris, "Span: An Energy-Efficient Coordination Algorithm for Topology Maintenance in Ad Hoc Wireless Networks," *Proc. of the International Conference on Mobile Computing and Networking*, pages 85–96, 2001.

[2] C. F. Huang, Y. C. Tseng, S. L. Wu, and J. P. Sheu, "Increasing the Throughput of Multihop Packet

Radio Networks with Power Adjustment," *International Conference on Compute, Communication and Networks*, f001.

[3] J.-R. Jiang, Y.-C. Tseng, C.-S. Hsu, and T.-H. Lai, "Quorum-Based Asynchronous Power-Saving Protocols for IEEE 802.11 Ad Hoc Networks," *ACM Journal on Mobile Networks and Applications*, Feb. 2005

[4] E.-S. Jung and N. H. Vaidya, "An Energy Efficient MAC Protocol for Wireless LANs," *INFOCOM 2002*, 2002.

[5] LAN MAN Standards Committee of the IEEE Computer Society, IEEE Std 802.11-1999, "Wireless LAN Medium Access Control (MAC) and Physical Layer (PHY) specifications," *IEEE*, 1999.

[6] C. E. Perkins and E. M. Belding-Royer, "Ad-hoc on-demand distance vector routing," *IEEE Workshop on Mobile Computing Systems and Applications*, pages 90–100, 1999.

[7] J. H. Ryu and D. H. Cho, "A New Routing Scheme Concerning Power-Saving in Mobile Ad-Hoc Networks," *Proc. of IEEE International Conference on communications*, 3:1719–1722, 2000.

[8] J. H. Ryu, S. Song, and D. H. Cho, "A Power-Saving Multicast Routing Scheme in 2-tier Hierarchical Mobile Ad-Hoc Networks," *Proc. of IEEE Vehicular Technology Conference*, 4:1974–1978, 2000.

[9] Y. C. Tseng, C. S. Hsu, and T. Y. Hsieh, "Power-Saving Protocols for IEEE 802.11-Based Multi-Hop Ad Hoc Networks," *IEEE INFOCOM*, 2002.

[10] R. Wattenhofer, L. Li, P. Bahl, and Y. M. Wang, "Distributed Topology Control for Power Efficient Operation in Multihop Wireless Ad Hoc Networks," *IEEE INFOCOM*, pages 1388–1397, 2001.