

A Ka-Band (32 GHz) Beacon Link Experiment (KABLE) With Mars Observer

A. L. Riley

Spacecraft Telecommunications Equipment Section

D. M. Hansen and A. Mileant

Telecommunications Systems Section

R. W. Hartop

Radio Frequency and Microwave Subsystems Section

A proposal for a Ka-Band (32 GHz) Link Experiment (KABLE) with the Mars Observer mission has been submitted to NASA. The experiment will rely on the fourth harmonic of the spacecraft X-band transmitter to generate a 33.6 GHz signal. The experiment will rely also on a DSN receiving station equipped to simultaneously receive X- and Ka-band signals. The experiment will accurately measure the spacecraft-to-Earth telecommunication link performance at Ka-band and at X-band (8.4 GHz).

I. Introduction

This article describes a proposal to implement the Mars Observer spacecraft (MO) with a Ka-band beacon to enable a Ka-Band Link Experiment (KABLE). The experiment will measure and document the Ka-band (32 GHz) deep space communications link advantage with respect to the X-band (8.4 GHz) link. Implementation of a Ka-band beacon in the Mars Observer spacecraft and a simultaneous X- and Ka-band receiving capability in a DSN R&D receiving station is required. Added benefits of the Ka-band beacon include the ability to calibrate plasma effects not possible with a single frequency radio link and the enhancement of gravitational wave experiments, relativistic bending experiments and spacecraft naviga-

tion. Radio science experiments are coordinated with the Mars Observer radio science team and are not a part of the proposal.

Propagation measurements and analyses show that a significant advantage can be achieved by using Ka-band instead of X-band for deep space communications and navigation. The performance advantage in the communications link can be as large as a factor of 10 and needs to be quantified with the precision required for future mission planning. Previous measurements of the effects that degrade deep space communications link performance suffered due to significant errors in the absolute accuracy of the separate evaluations. A simultaneous relative measurement of Ka-band and X-band

link performance will yield the necessary high accuracy results.

II. Experiment Objectives

The primary engineering objective of this experiment is to accurately measure and document the Ka-band spacecraft-to-Earth telecommunications link (downlink) performance with respect to the X-band downlink performance.

Parameters of interest include:

- (1) Effects of ground antenna pointing and efficiency as a function of elevation angle, wind, irregular atmospheric refraction and thermal gradients experienced at sunrise, sunset and during a variety of weather conditions.
- (2) Effects of water vapor and water droplets (clouds and rain) along the propagation path at various ground antenna elevations.
- (3) Effects of solar corona and solar wind.

Documentation of these telecommunications link parameters will provide accurate inputs for future deep space mission planning. This will enable future flight projects to maximize the benefits of using improved telecommunications link capabilities at Ka-band.

It is expected that this experiment will confirm the prediction that during 90% of the time the Ka-band telemetry link performance will exceed the X-band telemetry link performance by a factor of 6 to 10. The 90% time period is based on current knowledge of the effects of weather including wind, clouds, and rain. Recent data obtained during the Voyager Uranus encounter have added to evidence that shows the DSN X-band weather model to be overly pessimistic. This experiment will significantly increase knowledge about the effects of weather and enable the improvement of the DSN weather models both for X-band and Ka-band.

The frequency and timing stability of the entire link (Earth based transmitter to spacecraft and back to the Earth based receiver) will be measured and is expected to be near 1 part in 10^{15} . Use of a Ka-band link offers a factor of 16 reduction in the sensitivity to plasma effects over X-band. Use of simultaneous X- and Ka-band offers the additional capability to calibrate the plasma and thereby reduce its effect even more. This can result in a factor of at least 10 improvement in stability and calibration accuracy over existing systems and may lead the way to new discoveries through an improved radio science capability.

III. Experiment Description

The proposed experiment requires the use of the fourth harmonic of the spacecraft X-band downlink signal thereby providing a Ka-band downlink to a DSN R&D Earth station. In order to minimize cost and spacecraft impact, several design approaches will be investigated. Selection of the specific approach to be implemented will be made by the Mars Observer Project office. Design approaches include:

- (1) **Traveling-Wave Tube Amplifier (TWTA) Generation** of the fourth harmonic. This approach utilizes the fourth harmonic of the X-band downlink signal as generated by the TWTA; it is believed to be the least expensive and least intrusive to the spacecraft. Analysis is extremely difficult because the Ka-band signal must propagate through the X-band waveguide and components which are overmoded at Ka-band. Usefulness of this approach will be investigated for comparison with the other, better understood approaches in consideration of its possible use.
- (2) **Dual-Frequency Feed with Varactor Diode Quadrupler.** This approach uses a dual-frequency feed at the primary focal point of the antenna with a varactor diode assembly to produce the fourth harmonic of the X-band downlink signal. The details of the multiplier scheme are covered in the third approach. The multiplier package is attached to the focal point feed assembly, adds no additional X-band waveguide or components, uses the same amount of the X-band downlink power, and may add less mass and cost less than the third approach. A better understanding of the spacecraft antenna feed system is needed in order to evaluate this approach accurately.
- (3) **Separate Cassegrain Ka-Band Feed with Varactor Diode Quadrupler.** This approach is best understood and is being used here for scheduling and budgeting purposes; a detailed description follows.

The Ka-band beacon will consist of a passive frequency multiplier driven by an X-band signal coupled from the power amplifier output. The multiplier will produce a signal at the fourth harmonic (approximately 33.6 GHz) of the X-band downlink. This Ka-band signal will then be fed to the MO high-gain antenna for transmission to Earth. The Ka-band signal will be coherent with the X-band downlink signal and, when the X-band signal is phase modulated, will provide a modulated signal with four times the modulation index of the X-band signal. This will impact the resultant Ka-band carrier suppression and the effect on the experimental link performance. The Ka-band carrier signal-power-to-noise-spectral-density ratio (P_c/N_o) versus time for 20 mW transmitter power

is shown in Fig. 1 for a DSN 34 meter high-efficiency antenna during clear, dry weather. The time scale in these figures begins at Mars orbit insertion (August 1991). Typical link parameters are given in Table 1.

IV. Flight Hardware

The RCA Mars Observer spacecraft is shown in Fig. 2 with the high-gain antenna located on an extended boom. The antenna is mounted to the boom through a two-axis gimbal containing X-band waveguide rotary joints. The reflector is 1.0 meter in diameter, and the spacecraft transmitter produces 40 W of X-band power at the TWTA output. Figures 3 and 4 show a concept of the Ka-band experiment hardware mounted to the high-gain antenna. A block diagram is shown in Fig. 5.

The multiplier drive is obtained from a crossguide coupler which couples approximately 200 mW of X-band signal to the multiplier assembly, reducing the transmitted X-band signal by 1%. X-band to Ka-band conversion efficiency of 25% or more is theoretically possible but to keep the design simple and cost low a minimum conversion efficiency of 10% will be considered to produce a minimum output power of 20 mW at Ka-band. The quadrupler will consist of a cascade of two frequency doublers. Each doubler will consist of a varactor diode with an input low-pass matching network and output band-pass matching network. The varactors will be self-biased such that bias current is generated by rectification of the RF signal by the varactor. Thus, no bias supply voltage is required from the spacecraft.

The Ka-band signal is fed from the multiplier through the back of the high-gain antenna reflector to a Ka-band feed. The signal from the feed is reflected from a dichroic Cassegrain subreflector to illuminate the main reflector. The X-band signal is transmitted through the subreflector. The mass of the additional hardware is estimated to be about 1 kilogram.

Thus, the RCA proposed antenna design is modified to provide the following interfaces with the Ka-band experiment:

- (1) An X-band 20 dB crossguide coupler to provide multiplier input signal.
- (2) A mounting bracket on the back of the reflector for the frequency multiplier.
- (3) A port through the back of reflector for Ka-band feed.
- (4) A mounting bracket for the dichroic subreflector.

A number of issues require further investigation. These include an understanding of the mass handling margin of the

high-gain antenna gimbal and boom system, and the impact of the high-gain antenna thermal environment upon the frequency multiplier operation.

The equipment will be designed to enable verification of proper multiplier operation through the use of a bias voltage test point located on the multiplier assembly. Measurement of this bias voltage will be done manually; this measurement is not required after launch.

V. Ground Support Equipment

A new 34-meter antenna for Research and Development at the Venus Site, Goldstone, California, is planned for completion in 1990. The DSN Advanced Systems Program supports a number of ongoing development efforts (RTOPs) that will equip this antenna to simultaneously receive 8.4 GHz (X-band) and 33.6 GHz (Ka-band) signals. This ground station will provide high-aperture efficiency and ultra-low-noise receiving systems with frequency stability of approximately one part in 10^{15} . The station will include a multifrequency beam waveguide feed system, X- and Ka-band ultra-low-noise amplifiers (cryogenically cooled masers and high-electron mobility transistors), hydrogen maser frequency standards, fiber optic distribution systems, an ultra-stable 100 kW X-band (7.145–7.190 GHz) transmitter, receivers, a spectrum analyzer with -180 dBm sensitivity and one hertz resolution, and other advanced signal, and data processing and recording equipment.

This experiment complements and enhances efforts within the DSN Advanced Systems Program to develop and demonstrate Ka-band station technology. The Ka-band link experiment will be closely coordinated with the DSN Advanced Systems Program so that no additional resources will be needed to develop, install, use, and maintain the ground support equipment.

VI. Mission Operations

The objectives of this experiment can be accomplished without causing any change to the Mars Observer Project mission plan. Tracking functions at the R&D Venus station will be coordinated with the Mars Observer mission manager. Scheduling of the Venus station will be accomplished and supported by the DSN Advanced Systems Program as has been and continues to be the approach used for other research activities in the DSN.

VII. Analysis and Report

The analysis of data acquired at the R&D Venus site in support of this experiment will quantify the following parameters:

- (1) The Ka-band downlink performance with respect to the X-band downlink performance.
- (2) Ground antenna pointing and efficiency as a function of elevation, wind, irregular atmospheric refraction and thermal gradients.
- (3) Effects of water vapor and water droplets along the propagation path at various ground antenna elevations.
- (4) Effects of solar corona and solar wind.

- (5) Total system "turn-around" frequency stability.

VIII. Conclusions

The proposed experiment can provide an initial comparison of Ka- and X-band link performance using an actual deep space communication channel at a relatively modest cost. It is one of the important steps in the continuing evolution of Ka-band capability for deep space communications.

Table 1. Typical Mars Observer Ka-band link parameters

Spacecraft

Output power	20.0 mW
Frequency	33.6 GHz
Antenna diameter	0.5 meter (effective illuminated area)
Antenna efficiency	60.0%
Antenna gain	42.7 dB
Pointing loss	2.71 dB (0.5 degree pointing error)
Carrier Suppression	3 dB at Ka-band

Ground Station

Antenna diameter	34 meters
Antenna gain	79.7 dB
Antenna elevation	30 degrees
Pointing error	0.001 degree
System temperature	29.1 K
Weather	Clear and dry, no wind

Link Reliability

To achieve 90% or 95% reliability, additional margins are required to account for weather and link tolerances. This experiment will record adequate data over a several year time period to define the margins needed for 90% or 95% link reliability.

Carrier Signal-Power-to-Noise-Spectral-Density-Ratio (P_c/N_o)

The objectives of this experiment can be met when the received P_c/N_o ratio exceeds 10 dB. Figure 1 shows P_c/N_o ratios ranging from 60 (18 dB) to 1000 (30 dB); these higher ratios enable increased measurement precision.

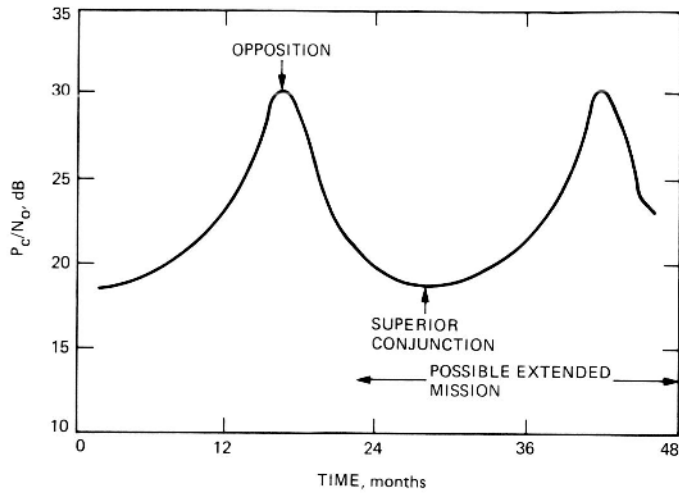

Fig. 1. Ka-band carrier signal-power-to-noise-spectral-density ratio versus time expected for 20 mW Mars Observer beacon (see Table 1)

ORIGINAL PAGE IS
OF POOR QUALITY

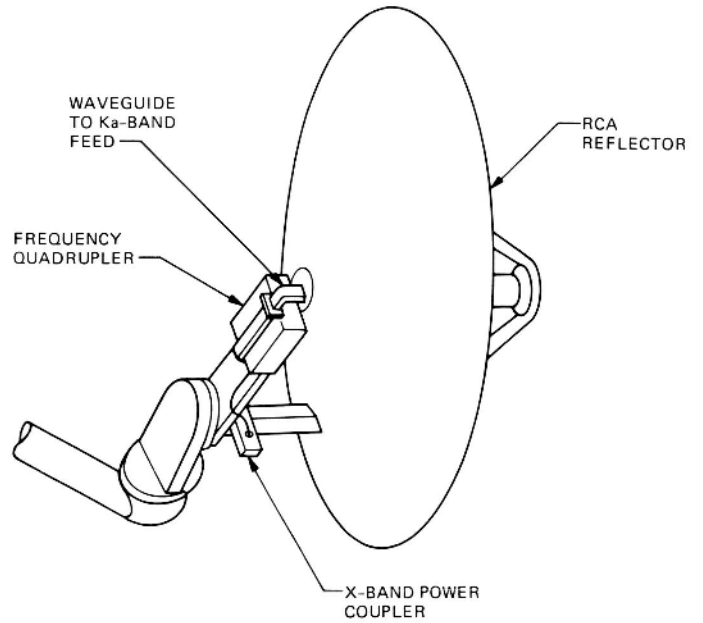

Fig. 3. Mars Observer Ka-Band Link Experiment (KABLE) hardware, back view

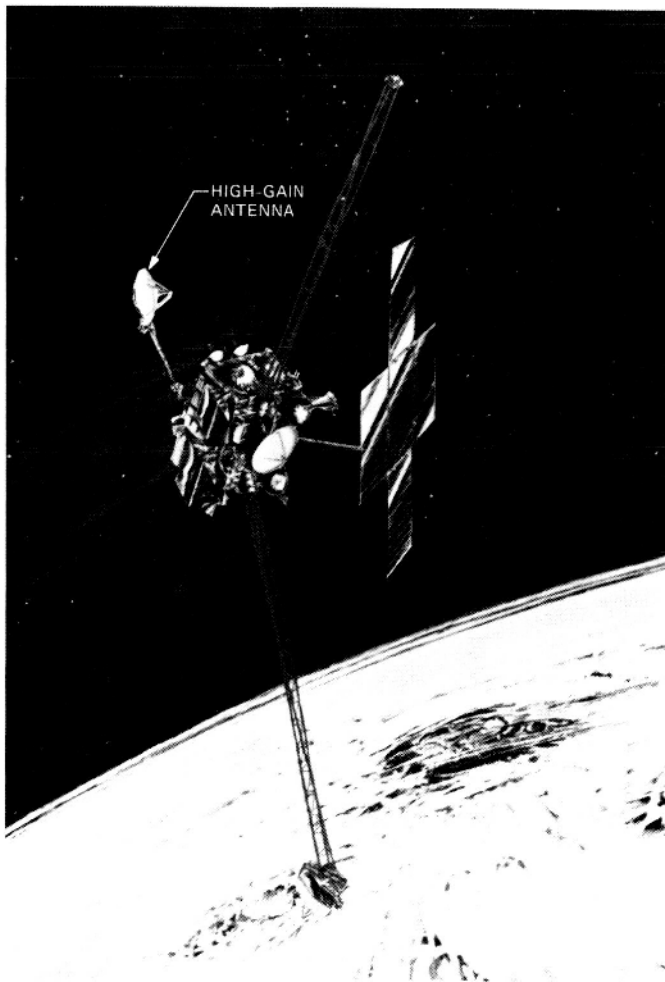

Fig. 2. Mars Observer spacecraft

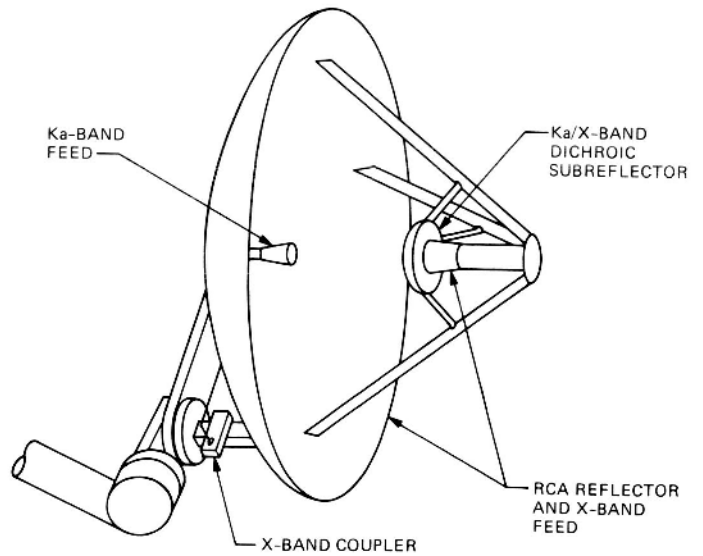

Fig. 4. Mars Observer Ka-Band Link Experiment (KABLE) hardware concept, front view

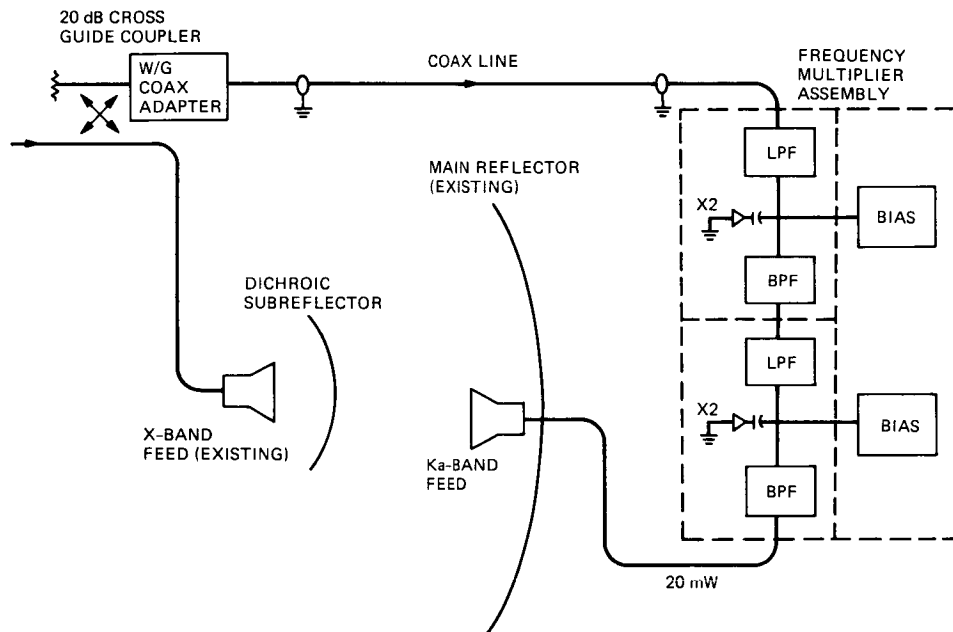

Fig. 5. Mars Observer Ka-Band Link Experiment (KABLE) block diagram