

A Large-Scale Wavelength Routing Optical Switch for Data Center Networks

*Ken-ichi Sato, Hiroshi Hasegawa, and Tomonobu Niwa, Nagoya University
Toshio Watanabe, NTT Photonics Laboratories*

ABSTRACT

Intra-data-center traffic is estimated to be about four times global Internet traffic and is continuously increasing. Applying optical switching to data center networks will increase network bandwidth and reduce power consumption while meeting the traffic requirements. One of the major attributes of the optical switch must be scalability. The wavelength routing switch is a promising technology for the development of 1000×1000 scale large port count optical switches. Recent advances are demonstrated.

INTRODUCTION

Intra-data-center traffic is estimated to be about four times that of global Internet traffic, and the compound annual growth rate (CAGR) is about 30 percent [1]. In a data center, traffic flow is changing from North-South to East-West, that is, between servers/storage within a data center rather than inbound/outbound traffic. It is impressive to note that, for example, a single 1 kbyte HTTP request generates 930 kbytes of internal network traffic [2]. Reflecting the traffic increase and the need for simplifying networks and cabling, and for enhanced scalability and flexibility, reduced tier network architectures that utilize giant throughput electrical switches are recently being considered [3]. The reduced tier architecture minimizes oversubscription of switch capacities and reduces the latency caused by the lack of network capacity. The front surface of the electrical switches tends to be fully covered with transceiver modules, and the power consumption limits the density. The increase in processing and communication capacities required in data centers has also caused a tremendous increase in the power consumption of electrical switches and routers. To fundamentally resolve the power consumption and transponder cost issues of large electrical switches, the offloading of large traffic flows from the electrical layer to the optical layer is expected to play a key role. In this context, new data center network architectures that exploit optical switching technologies are now being explored. Lever-

aging optical fast circuit switching alongside electrical packet switching is recognized to be one of the most attractive solutions [4–9]. With the hybrid network solution, optical circuit switching offers the ability needed to economically reconfigure networks to support giant data flows with low latency and can scale as needed to 40 or 100 Gb/s or even beyond without scaling hardware size or electrical power consumption. In the network, the giant data flows between specific top-of-rack (ToR) switches or pods will be delivered by optical circuit switches [4–9]. In a large data center, a server rack with a ToR switch is considered as a single endpoint system rather than a data center network. The effectiveness of this approach will be enhanced as the ratio of giant data flows (it is well known that in data centers a small number of large flows dominates total traffic volume) and interface speeds increase. However, clear requirements for optical circuit switches in data centers or the break-even points against electrical switching have yet to be identified. Although the maturity level of today's optical switching technology currently prevents this, it is conceived that 100–300 ports will be inadequate, and switching times of 10–100 μ s will be transformative for effectively offloading traffic from electrical Ethernet switches [10].

To implement optical circuit switching, the various technologies being considered include; high port count micro electromechanical system (MEMS) switches [4,5], wavelength-selective switches (WSSs) [6], combinations of wavelength tunable lasers and arrayed waveguide gratings (AWGs) [7, 8], and semiconductor optical amplifier (SOA)-based switches [9]. The major parameters used to determine approach effectiveness are switch scalability and switching speed [10], to say nothing of cost. The target switching time can be sub-microsecond [7] with switch size of 1000×1000 . Three-dimensional MEMS switches have relatively slow switching times, longer than a few milliseconds. The switching time of the liquid-crystal-on-silicon (LCoS)-based WSS is usually more than 100 ms. The SOA-based approach will attain the target speed, but the power consumption and optical signal-to-noise ratio of the cascaded SOA gates severely limit

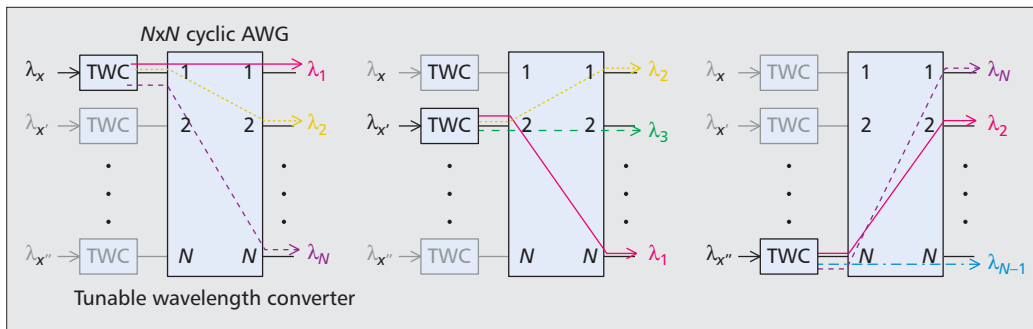

Figure 1. Wavelength routing of a cyclic AWG for different input ports.

the available scale. At present, a 16×16 SOA-based switch that has been fabricated on a single chip integrates more than 1000 functional components [9]. The wavelength routing approach that combines wavelength tunable lasers and arrayed waveguide grating routers (AWGRs) exhibits some unique advantages. The switching speed is determined by the laser wavelength tunability, and tuning speeds can be less than 100 ns. Wavelength routing is a built-in function of the passive AWGR and does not need any optical path alignment manipulation at the manufacturing stage; space division switches such as 3D MEMS, on the other hand, require 10^6 manipulations to set 1000×1000 optical paths at the initial mirror setting stage. However, the major barrier is the scalability needed to reach the 1000 port count. This article discusses breakthrough technologies and demonstrates recent advances.

WAVELENGTH ROUTING SWITCH

Wavelength routing (WR) switches are capable of switching input signals to arbitrary output ports by changing the laser wavelength at each input port. When the input signal is optical, a tunable wavelength converter (TWC), which can be a compact tunable transceiver (e.g., a type of commercially available tunable multirate XFP transceiver), will be applied. A basic $N \times N$ WR switch that routes N equally spaced wavelengths $\lambda_1, \dots, \lambda_N$ is shown in Fig. 1. It consists of N TWCs and a single $N \times N$ cyclic AWG whose free spectral range (FSR) is N times the channel frequency spacing. In the cyclic AWG, the relation among the input port number (# input port), the output port number (# output port), and wavelength index number (# wavelength) is given by

$$\# \text{ output port} = (\# \text{ wavelength} - \# \text{ input port})_{\text{mod } N} + 1 \quad (1)$$

The input/output ports of the cyclic AWG are efficiently utilized. The WR switch utilizing a single $N \times N$ cyclic AWG offers a simple architecture for wavelength routing, and this architecture achieves non-blocking $N \times N$ switching. However, there are two major barriers to attaining large port count cyclic AWGs. One is the deviation of passband center frequencies from the International Telecommunication Union Telecommunication Standardization Sector

(ITU-T) grid. It becomes very large as N becomes large [11], so the number of input/output ports, N , is limited in practice. For example, with a 32×32 AWG for 32 channels with 100 GHz spacing, the worst frequency deviation value is 44.5 GHz. One possible approach to mitigating the effect of AWG frequency deviation is to tune the wavelengths of each TWC to the center of each passband of the AWG; however, controlling tunable lasers becomes complicated (present commercially available tunable transceivers use a simple frequency locker to conform to the ITU-T grid). Good performance and cost effectiveness can be attained by developing a large-scale WR switch using small AWGs with small passband deviation.

Another major issue to be resolved is the crosstalk that increases with the port count increase [8]. In order to realize large-scale optical switches, one viable solution is to bridge several WR parts by optical switches. For example, a 448×448 optical crossconnect (OXC) prototype was demonstrated [8] where 100 GHz spaced cyclic 32×32 AWGs are bridged by delivery and coupling (DC) switches [12] and wavelength-division multiplexing (WDM) couplers. More than 64 100-GHz-spaced wavelengths are used for routing, which imposes the costly requirement of wide-range laser tunability. OXC port count can be effectively enlarged by increasing the port count of the cyclic AWGs. The uniform loss and cyclic frequency (ULCF) configuration has been developed; [11] shows a prototype 64×64 AWG router that utilizes a 64×128 AWG and 64×2 couplers, where each pair of AWG output ports are bridged as one router output so that the passband deviation is reduced. However, the port count is still too small to support the envisaged applications; increasing the port number requires a larger port count component AWG and more couplers, which seems to be impractical.

In order to resolve the above mentioned problems with realizing large-scale AWG routers, a novel architecture that cascades small cyclic AWGs of different sizes has recently been proposed [13]. The architecture exhibits the salient features of:

- ITU-T specified fixed grid frequencies are utilized (a version of commercially available cost-effective transceivers can be utilized).
- The use of small cyclic AWGs offers a smaller total crosstalk level.
- High scalability sufficient to reach 1000

Wavelength routing (WR) switches are capable of switching input signals to arbitrary output ports by changing the laser wavelength at each input port. When the input signal is optical, a tunable wavelength converter (TWC), which can be a compact tunable transceiver, will be applied.

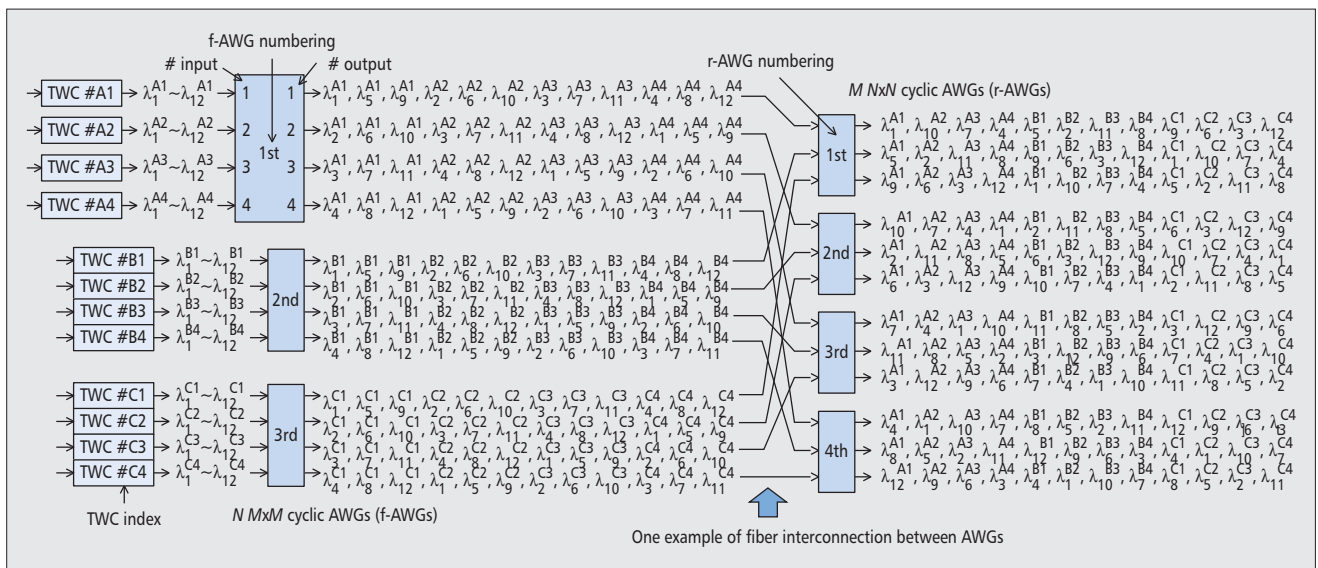

Figure 2. Novel wavelength routing switch architecture ($MN \times MN$ subsystem) and the wavelength map ($M = 4$ and $N = 3$).

ports.

- Good modular growth capability.

So far, the WR capability of a 90×90 50-GHz-spaced WR system prototype that consists of discrete components has been experimentally confirmed [13], and a 270×270 optical switch that consists of $90 \times 3 \times 3$ DC-switches [12] and three 90×90 proposed AWG subsystems, all of which are mounted in a $370 \times 230 \times 120$ mm³ box has been demonstrated, and optical performance was confirmed by transmission experiments [14]. The details are presented below.

WAVELENGTH ROUTING SWITCH EMPLOYING CYCLIC AWG INTERCONNECTION

Figure 2 shows the novel wavelength routing switch configuration that combines small AWGs of different sizes. In this configuration, $NM \times M$ cyclic AWGs (front[f]-AWGs) and $MN \times N$ cyclic AWG (rear[r]-AWGs) are connected so that each f-AWG is connected to all r-AWGs by single fibers, where an example for the case of $M = 4$ and $N = 3$ is shown for simplicity. The AWG input port index (#input), output port index (#output), f-AWG and r-AWG numbering, and TWC indices (#A1, #A2, ..., #C4) are given in Fig. 2. The figure explains how the AWG output port index is changed according to the input wavelength variation. Each TWC can select any wavelength from λ_1 to λ_{12} , and hence any output port can be selected by assigning an appropriate wavelength at TWC. Wavelength indices of the output wavelengths from each f-AWG output port (e.g., $\lambda_1, \lambda_{1+M}, \lambda_{1+2M}, \dots$) appear cyclically with M spacing, and these wavelengths need to be delivered to different output ports in the next stage AWGs. Hence, the degrees of AWG port count, M and N , must differ from each other. The port counts of the f-AWGs and r-AWGs are determined by considering the following restriction; M and $N (\geq 2)$

must be mutually co-prime numbers [20] so that any input port can be connected to any output port with a specific wavelength. For example, $(M, N) = (N + 1, N)$ fulfills this requirement. This configuration has the same wavelength routing capability as a single $MN \times MN$ AWG. If M and N are not co-prime (e.g., their greatest common divisor is 2), only half of the output ports can be used. Various connection patterns are possible between f-AWG output ports and r-AWG input ports. Let i ($= 1, 2, \dots, N$) be the index of f-AWG and j ($= 1, 2, \dots, M$) that of r-AWG. Let $\#f_{in}^i, \#f_{out}^j$ ($= 1, 2, \dots, M$) and $\#r_{in}^j, \#r_{out}^i$ ($= 1, 2, \dots, N$) be the indices of input/output ports of the i th f-AWG and j th r-AWG, respectively. In Fig. 2, we assume that the i th f-AWG is connected to the j th r-AWG so that $\#f_{out}^i = j$ and $\#r_{in}^j = i$; this is one example of the fiber interconnections possible.

There are several advantages to this architecture over the conventional approach that suit single large-scale AWGs. A large port count routing device can be obtained by choosing large N and M values. The deviations from the ITU-T grid are suppressed due to the adoption of small-size component AWGs, which avoids the special arrangement needed in [11], and the port count can be much larger than that in [11]. This configuration provides modular growth capability in terms of TWCs and f/r-AWGs. For example, suppose that an $L \times L$ ($L < MN$) switch is necessary in the initial installation. For this we connect $\lceil L/M \rceil M \times M$ AWGs and $\lceil L/N \rceil N \times N$ AWGs, where $\lceil \cdot \rceil$ represents the ceiling operation. This switch can be gradually expanded up to $MN \times MN$ by adding $M \times M$ and $N \times N$ AWGs. To enable this in a simple manner, interconnecting fibers among separate modules should be installed from the outset. The major cost of the system comes from optical device modules, not from interconnect fibers and multi-fiber connectors.

Table 1 shows examples of combinations of switch scale and parameters M and N . In theory, this configuration can achieve a very large-scale

WR function, for example, 210×210 in the case of $M = 14$, $N = 15$, but overall system optimization is important. The tunable frequency range of TWC limits the size of the proposed switch; an $MN \times MN$ wavelength routing switch requires a TWC tuning range of $MN \times$ (channel spacing) for switching. Commercially available tunable transceivers cover the entire C-band, realizing $MN \cong 90$ for 50 GHz grid spacing. This problem can be resolved by bridging multiple wavelength switches (e.g., by using $K \times K$ delivery-coupling type switches [12]).

In the proposed configuration, the basic requirement for interconnection is that each pair of f-/r-AWGs is bridged by an independent fiber. In other words, there is room for optimizing the selection of output/input ports of the AWGs (the interconnection pattern shown in Fig. 2 is but one example). The objective of optimization is to minimize the worst loss, which can be achieved by configuring the connection so that f-/r-AWGs will not yield large loss simultaneously. However, the number of possible connections is extremely large (the number of possible combinations is $(M!)^N \times (N!)^M$) and hence it is hard to find the truly optimal connection. A method to find suboptimal solutions by local search has been developed. Each f-/r-AWG has almost the same transmission loss characteristics; loss between center input/output ports is generally small, while that between edge ports is large. For each pair of f-/r-AWGs, we specify the input port number of r-AWG for the interconnecting fiber as follows:

$$\#r_{in}^j = (i + j - 2)_{\text{mod } N} + 1 \quad (2)$$

where i and j are the respective indices of the f-/r-AWGs. For each f-AWG, input port indices of the r-AWGs that are as different as possible are assigned so as to minimize the slant among f-/r-AWG pairs. Next, the worst loss is minimized by checking all possible assignments of output ports of the f-AWGs. The number of possible assignments in each f-AWG is $M!$, and hence the computation time of this search is substantially reduced.

Figure 3a shows the $KMN \times KMN$ WR-switch architecture with $MN K \times K$ DC-switches and $K MN \times MN$ AWG subsystems. The DC-switches connect each tunable laser (TL) to one of the desired AWG subsystems. These DC-switches are simple and easy to fabricate because they consist of couplers and switches that can be easily implemented with planar lightwave circuit (PLC) technology. Recently, an 8×12 DC-switch was fabricated on a single PLC chip and the transmission loss was reported to less than 14.5 dB, including intrinsic optical coupler loss of 10.8 dB [15]. Each AWG subsystem can be realized by utilizing a single $NM \times NM$ AWG; however, the port count number is limited, as mentioned before. The AWG subsystem architecture solves this problem by combining small-size cyclic AWGs as explained above (Fig. 3a).

PROTOTYPE SYSTEM

Figure 3b shows a fabricated 90×90 AWG subsystem architecture consisting of 10 9×9 cyclic

Switch size in Fig. 2	M	N	No. of necessary wavelengths
210 × 210	14	15	210
208 × 208	13	16	208
195 × 195	13	15	195
182 × 182	13	14	182
156 × 156	12	13	156
154 × 154	11	14	154
143 × 143	11	13	143
132 × 132	11	12	132
130 × 130	10	13	130
110 × 110	10	11	110
99 × 99	9	11	99
90 × 90	9	10	90
88 × 88	8	11	88
72 × 72	8	9	72
70 × 70	7	10	70

Table 1. Examples of switch scale.

AWG and 9 10×10 cyclic AWG. In this example, we assume that the i th 9×9 AWG is connected to the j th 10×10 AWG so that ($\#$ output of i th 9×9 AWG) = j , and ($\#$ input of j th 10×10 AWG) = i , as one connection example (Fig. 3b). $K = 10$ and 90×90 AWG subsystems, for example, yields a 900×900 large-scale optical switch. The system provides good modular growth capability in terms of each AWG.

The fabricated 9×9 cyclic AWG and 10×10 cyclic AWG have channel spacing of 50 GHz, and FSR values of 450 GHz and 500 GHz, respectively. Five 9×9 AWGs or five 10×10 AWGs are included in a single PLC chip as shown in the insertions of Fig. 3b. A photo of the woven 90-optical-fiber interconnection part between the 9×9 and 10×10 AWGs is also shown in Fig. 3b, which is made very compactly and cost effectively. The typical insertion loss variations on the 50 GHz spaced ITU-T grid for both AWG types are depicted in Fig. 4, where the vertical bar on each input port represents loss variations among the 90 channels. In Figs. 4a and 4b, the worst loss was 6.4 dB and 6.9 dB, respectively. Loss suppression in a cascade, f-AWG to r-AWG, can be achieved by changing the connecting fiber configurations between front and rear AWGs so that 9×9 and 10×10 cyclic AWGs will not exhibit large loss simultaneously as explained before. The worst loss recorded from the 90×90 subsystem was 10.2 dB, which is 3.1 dB smaller than the possible

The objective of optimization is to minimize the worst loss, which can be achieved by configuring the connection so that f/r AWGs will not yield large loss simultaneously. However, the number of possible connections is extremely large, and hence it is hard to find the truly optimal connection.

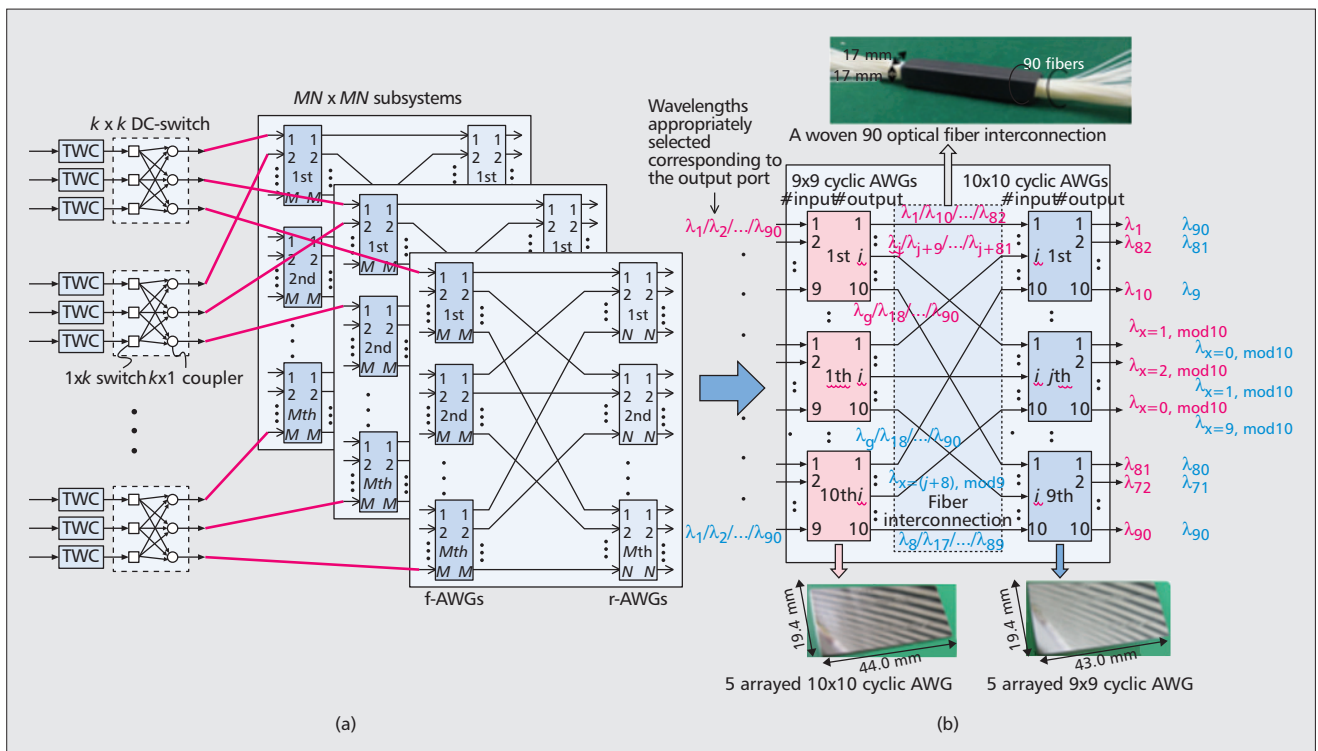

Figure 3. $KMN \times KMN$ WP-switch architecture ($K = 3$) and fabricated 90×90 AWG subsystem: a) $KMN \times KMN$ WP-switch architecture ($K = 3$); b) 90×90 AWG subsystem using 9×9 and 10×10 AWGs.

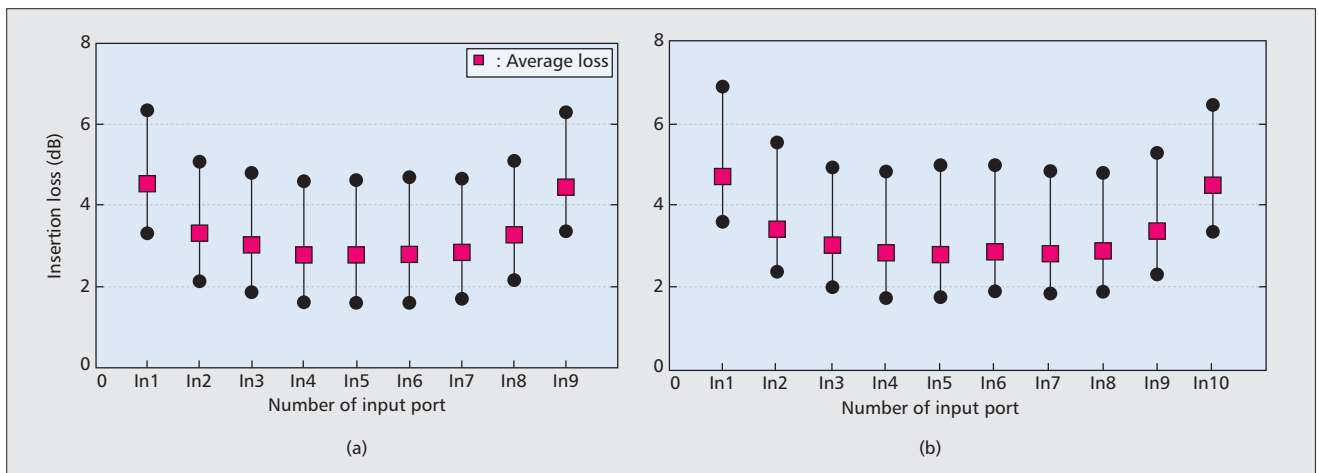

Figure 4. Typical insertion loss of cyclic AWG: a) 9×9 cyclic AWG; b) 10×10 cyclic AWG.

worst loss of $6.4+6.9$ dB.

A 270×270 WR-switch was developed using 90×3 DC-switches and three 90×90 AWG subsystems. Five 3×3 DC-switches are integrated on a small PLC chip. The average loss of the typical 3×3 DC-switch was 7.4 dB, which includes the inherent 1×3 coupler loss of 4.8 dB. The photograph in Fig. 5 shows the developed 270×270 WR-switch compactly assembled in a $370 \times 230 \times 120$ mm³ box. In order to verify the routing function, transmission experiments were executed. In this experiment, we input 90 wavelengths with 50 GHz spacing on the ITU-T grid ($191.55 + 0.05 \times n$ [THz]; $n = 0 \sim 89$) to different four input ports of the WR-switch simultane-

ously. All signals were intentionally input to the same AWG subsystem, and typical output spectra at three output ports (OUT10, OUT45, OUT80) are shown in Figs. 5a and 5b (four signals are routed to each port). Each wavelength was confirmed to be properly routed. Figure 5c shows the insertion loss of the system. The average and maximum loss was 14.9 and 19.0 dB. The bit error rate at 10 Gb/s was also measured at the typical wavelength of 1550.116 nm (Fig. 5d). The power penalty at 10^{-9} was 0.068 dB.

CONCLUSION

This article introduces a novel, highly scalable

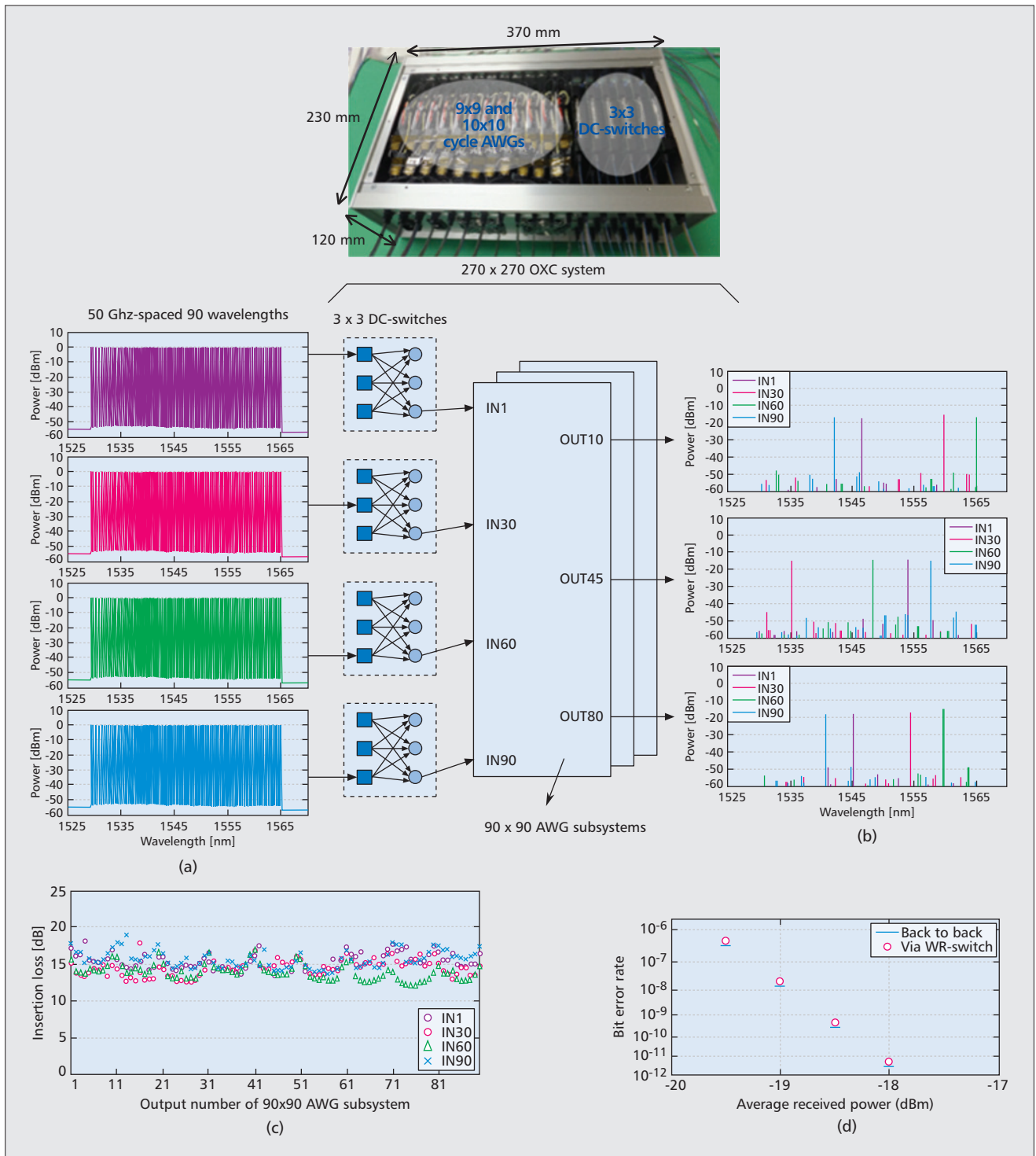

Figure 5. Experiment on developed 270 × 270 OXC system: a) input signals; b) output signals; c) insertion loss; d) measured bit error rate (1550.111 nm).

optical switch architecture that exploits the wavelength routing capability of AWGs. The resulting switches consist of small cyclic AWGs and provide excellent modular growth capabilities. A 270 × 270 prototype switch was fabricated using PLC technologies, and we verified its technical feasibility through transmission experiments. The transmission loss that stems from relying on passive components should be com-

pensated; pump laser shared cost-effective EDFAs or SOAs are practical solutions. Si photonics technologies or III-V semiconductor technologies may be utilized in the future, which would reduce size dramatically. The switch port count can be expanded to exceed 1000 × 1000 (i.e., port counts sufficient for data center application). The wavelength routing switch requires tunable transceivers instead of fixed wavelength

To allow the dynamic wavelength services envisaged and to avoid the costly manual operation of current ROADMs, CDC capabilities are of prime importance. To effectively realize these capabilities, large-scale optical switches are effective. The technologies described herein can be applied to create them.

transceivers, which are commonly utilized for Ethernet switches; hence, the price difference between them should be considered when we apply wavelength routing optical switches.

Another potential application area of this large-scale optical switch is the reconfigurable add/drop multiplexer (ROADM). ROADMs are now widely deployed, but current ROADMs do not offer the colorless, directionless, and contentionless (CDC) add/drop capabilities that would allow flexible bridging of any wavelength path in any transmission-line side fiber to any transponder. To allow the dynamic wavelength services envisaged and avoid the costly manual operation of current ROADMs, CDC capabilities are of prime importance. To effectively realize these capabilities, large-scale optical switches are effective. The technologies described herein can be applied to create them.

ACKNOWLEDGMENT

The authors would like to thank Dr. Yoshiteru Jinnouchi, NTT Electronics Co., for his contributions to the prototype system development, and Mr. Akito Nishimura, Fujikura Ltd., for his contributions in realizing the fiber interconnects. A part of this work was supported by NEDO Green IT Project and KAKENHI (23246072).

REFERENCES

- [1] Cisco Global Cloud Index: Forecast and Methodology, 2011–2016.
- [2] N. Farrington, "Facebook's Data Center Network Architecture," *IEEE Opt. Interconnects Conf.*, Santa Fe, NM, TuB5May 5–7, 2013.
- [3] C. F. Lam, "Optoelectronic Technologies for Datacenter Networking," *OFC/NFOEC 2010*, NWA3, Mar. 2010.
- [4] N. Farrington et al., "Helios: A Hybrid Electrical/Optical Switch Architecture for Modular Data Centers," *Proc. ACM SIGCOMM 2010*, pp. 339–50.
- [5] G. Wang et al., "c-Through: Part-time Optics in Data Centers," *Proc. ACM SIGCOMM*, (New Delhi, India), Aug. 2010, pp. 327–38.
- [6] N. Farrington et al., "A 10 T/s Hybrid Optical-Circuit/Electrical-Packet Network for Datacenters," *OFC/NFOEC 2013*, Anaheim Mar. 2013.
- [7] Y.-K. Yeo, "Large Port-Count Optical Cross-connects for Data Centers," *Photonics in Switching*, Fr-S37-I12, Corsica, France, Sept. 11–14, 2012.
- [8] P. N. Ji et al., "Design and Evaluation of a Flexible-Bandwidth OFDM-Based Intra Data Center Interconnect," *IEEE J. Selected Topics in Quantum Electronics*, vol. 19, No. 2, Mar./Apr. 2013.
- [9] A. Wonfor et al., "Large Port Count High-Speed Optical Switch Fabric for Use Within Datacenters," *J. Opt. Commun. and Net.*, vol. 3, issue 8, 2011, pp. A32–39.
- [10] A. Vahdat, "Delivering Scale Out Data Center Networking with Optics — Why and How," *OFC/NFOEC 2012*, OTu1B.1, San Diego, CA, Mar. 2012.
- [11] S. Kamei et al., "N × N Cyclic-Frequency Router With Improved Performance Based on Arrayed-Waveguide Grating," *J. Light. Tech.*, vol. 27, no. 18, Sep. 2009, pp. 4097–4104.
- [12] K. Sato, *Advances in Transport Network Technologies: Photonic Networks, ATM, and SDH*, Artech House, 1996.
- [13] T. Niwa et al., "Large Port Count Wavelength Routing Optical Switch that Consists of Cascaded Small-Size Cyclic Arrayed Waveguide Gratings," *IEEE Photon. Technol. Lett.*, vol. 24, No. 22, Nov. 2012, pp. 2027–30.
- [14] T. Niwa, H. Hasegawa, and K. Sato, "A 270 × 270 Optical Cross-Connect Switch Utilizing Wavelength

Routing with cascaded AWGs," *OFC/NFOEC '13*, OTh1A.3, Anaheim, Mar. 17–21, 2013.

- [15] T. Watanabe et al., "Silica-Based PLC Transponder Aggregators for Colorless, Directionless, and Contentionless ROADM," *OFC/NFOEC '12*, OTh3D.1.

BIOGRAPHIES

KEN-ICHI SATO [F] (sato@nuee.nagoya-u.ac.jp) is currently a professor at the Graduate School of Engineering, Nagoya University, and he is an NTT R&D Fellow. Before joining the university in April 2004, he was an executive manager of the Photonic Transport Network Laboratory at NTT. His R&D activities cover future transport network architectures, network design, OA&M systems, photonic network systems including optical cross-connect/ROADM and photonic IP routers, and optical transmission technologies. He has authored/co-authored more than 350 research publications in international journals and conferences. He holds 50 granted patents and more than 100 pending patents. He received his B.S., M.S., and Ph.D. degrees in electronics engineering from the University of Tokyo, Japan, in 1976, 1978, and 1986, respectively. He received the Young Engineer Award in 1984, the Excellent Paper Award in 1991, the Achievement Award in 2000, and the Distinguished Achievement and Contributions Award in 2012 from the Institute of Electronics, Information and Communication Engineers (IEICE) of JAPAN, and the Best Paper Awards in 2007 and 2008 from IEICE Communications Society. He was also the recipient of the Distinguished Achievement Award of the Ministry of Education, Science and Culture in 2002. His contributions to ATM and optical network technology development extend to co-editing five *IEEE JSAC* Special Issues and one *IEEE Journal on Lightwave Technologies* Special Issue, organizing several workshops and conference technical sessions, serving on numerous committees of international conferences including OFC and ECOC, authoring a book, *Advances in Transport Network Technologies* (Artech House), and co-authoring 14 other books. He is a Fellow of the IEICE of Japan.

HIROSHI HASEGAWA [M] received B.E., M.E., and D.E. degrees, all in electrical and electronic engineering, from Tokyo Institute of Technology, Japan, in 1995, 1997, and 2000, respectively. From 2000 to 2005, he was an assistant professor of the Department of Communications and Integrated Systems, Tokyo Institute of Technology. Currently he is an associate professor at Nagoya University. His current research interests include photonic networks, image processing (especially super-resolution), multidimensional digital signal processing, and time-frequency analysis. He received the Young Researcher Awards from the Society of Information Theory and Its Applications (SITA) and IEICE in 2003 and 2005, respectively.

TOMONOBU NIWA received his B.E. and M.E. degrees in electronics engineering and computer engineering from Nagoya University in 2011 and 2013, respectively. His major interests include optical functional devices such as large-scale switches and tunable filters. He is currently working with KDDI.

TOSHIO WATANABE [M] received B.E., M.E., and Dr.Eng. degrees in organic and polymeric materials engineering from the Tokyo Institute of Technology in 1990, 1992, and 2001, respectively. In 1992 he joined the NTT Opto-Electronics Laboratories, Tokai-mura, Japan, and has since been involved in research on polymeric materials for optical waveguides. From 1997 to 1999, he was with the NTT Optical Network Systems Laboratories, Yokosuka, Japan, where he researched photonic network systems. From 1999 to 2005, he was involved in developing silica-based planar lightwave circuit optical switches. From 2005 to 2008, he was with the NTT Access Network Service Systems Laboratories, Chiba, Japan, where he worked on the development of WDM systems. Since 2008, he has been with the NTT Photonics Laboratories, Atsugi, Japan, where he is working on research of photonic node devices. He is a member of the Japan Society of Applied Physics. He received the Microoptics Conference Paper Award in 2011.