

9-1994

A Lion Lentivirus Related to Feline Immunodeficiency Virus: Epidemiologic and Phylogenetic Aspects

Eric W. Brown

Program Resources, Inc./DynCorp

Naoya Yuhki

National Cancer Institute at Frederick

Craig Packer

University of Minnesota - Minneapolis

Stephen J. O'Brien

National Cancer Institute at Frederick, sobrien1@nova.edu

Follow this and additional works at: https://nsuworks.nova.edu/cnso_bio_facarticles



Part of the [Genetics and Genomics Commons](#), [Virology Commons](#), and the [Zoology Commons](#)

NSUWorks Citation

Brown, Eric W.; Naoya Yuhki; Craig Packer; and Stephen J. O'Brien. 1994. "A Lion Lentivirus Related to Feline Immunodeficiency Virus: Epidemiologic and Phylogenetic Aspects." *Journal of Virology* 68, (9): 5953-5968. https://nsuworks.nova.edu/cnso_bio_facarticles/216

This Article is brought to you for free and open access by the Department of Biological Sciences at NSUWorks. It has been accepted for inclusion in Biology Faculty Articles by an authorized administrator of NSUWorks. For more information, please contact nsuworks@nova.edu.

A Lion Lentivirus Related to Feline Immunodeficiency Virus: Epidemiologic and Phylogenetic Aspects

ERIC W. BROWN,¹ NAOYA YUHKI,² CRAIG PACKER,³ AND STEPHEN J. O'BRIEN^{2*}

Biological Carcinogenesis and Development Program, Program Resources, Inc./DynCorp,¹ and Laboratory of Viral Carcinogenesis,² National Cancer Institute, Frederick Cancer Research and Development Center, Frederick, Maryland 21702-1201, and Department of Ecology, Evolution and Behavior, University of Minnesota,³ Minneapolis, Minnesota 55455³

Received 23 February 1994/Accepted 16 June 1994

Feline immunodeficiency virus (FIV) is a novel lentivirus that is genetically homologous and functionally analogous to the human AIDS viruses, human immunodeficiency virus types 1 and 2. FIV causes immunosuppression in domestic cats by destroying the CD4 T-lymphocyte subsets in infected hosts. A serological survey of over 400 free-ranging African and Asian lions (*Panthera leo*) for antibodies to FIV revealed endemic lentivirus prevalence with an incidence of seropositivity as high as 90%. A lion lentivirus (FIV-Ple) was isolated by infection of lion lymphocytes in vitro. Seroconversion was documented in two Serengeti lions, and discordance of mother-cub serological status argues against maternal transmission (in favor of horizontal spread) as a major route of infection among lions. A phylogenetic analysis of cloned FIV-Ple *pol* gene sequences from 27 lions from four African populations (from the Serengeti reserve, Ngorongoro Crater, Lake Manyara, and Kruger Park) revealed remarkably high intra- and interindividual genetic diversity at the sequence level. Three FIV-Ple phylogenetic clusters or clades were resolved with phenetic, parsimony, and likelihood analytical procedures. The three clades, which occurred not only together in the same population but throughout Africa, were as divergent from each other as were homologous *pol* sequences of lentivirus isolated from distinct feline species, i.e., puma and domestic cat. The FIV-Ple clades, however, were more closely related to each other than to other feline lentiviruses (monophyletic for lion species), suggesting that the ancestors of FIV-Ple evolved in allopatric (geographically isolated) lion populations that converged recently. To date, there is no clear evidence of FIV-Ple-associated pathology, raising the possibility of a historic genetic accommodation of the lion lentivirus and its host leading to a coevolved host-parasite symbiosis (or commensalism) in the population similar to that hypothesized for endemic simian immunodeficiency virus without pathology in free-ranging African monkey species.

The global increase of human immunodeficiency virus (HIV) infection over the past decade has intensified efforts to understand the phylogenetic origins and population dynamics of the HIV types 1 and 2 (HIV-1 and HIV-2) lentiviruses, the causative agent of AIDS. Lentivirus infection in humans is thought to have emerged from a recent transspecies infection of an ancestral lentivirus that may previously have been harbored in two groups of nonhuman primates (2, 10, 17, 35). This inference is supported by the isolation of the simian immunodeficiency virus (SIV) SIV-CPZ, related to HIV-1, from a chimpanzee in Gabon and by the occurrence of SIV-SM, related to HIV-2, in sooty mangabeys (10, 19, 35, 48). SIVs from *Cercopithecus* species, African green monkeys, display extensive inter se genetic divergence, suggesting that SIV infection in nonhuman African primates may be an ancient event (21, 37).

Lentiviruses are highly unstable RNA viruses. The high error rates of the viral polymerase in DNA synthesis result in the rapid evolution of genetic variants following initial infection of the host organism (12, 18, 22, 46). These evolving retroviral variants, or quasispecies, continue gathering mutations in vivo, resulting in the maintenance of a genetically diverse retroviral population throughout the term of viremia (4, 13). Quasispecies have been observed to diverge as much as 5% across the proviral genome and are capable of divergent and convergent evolutionary schemes (3, 20). The differentia-

tion of HIV quasispecies may ultimately lead to the formation of "escape variants," pathological genomic mutants capable of avoiding host immune surveillance and possibly of enhancing disease progression (31, 43).

Lentiviruses closely related to HIV have been isolated from monkeys, goats, sheep, horses, cattle, and cats (15, 17, 23, 36, 37, 48, 49). The feline immunodeficiency virus (FIV) is a T-lymphotropic lentivirus that causes immune suppression by gradually depleting the CD4 T-cell subsets in domestic cats (*Felis catus*) (1, 42, 55). FIV infection of the domestic cat provides a useful small animal model for the study of HIV infection in humans (44, 46). Like HIV infection of humans, FIV causes gradual dysfunction of the feline immune system which results in immune deficiency and opportunistic infections in infected hosts (42, 55). Although other transmission modes have not been adequately explored, FIV appears to be spread via the saliva during biting (54, 55). Antibodies to FIV have been detected in several nondomestic felid species, including cheetahs, pumas, bobcats, jaguars, and leopards (5, 7, 8, 25, 37).

East African lions (*Panthera leo*) inhabit the Serengeti reserve and Ngorongoro Crater in Tanzania. Although these lion habitats are contiguous in East Africa, the two populations reflect quite different natural histories. The Ngorongoro Crater lions are known to have undergone a series of population bottlenecks that had previously reduced the Crater population to as few as 10 individuals (29, 32, 41, 53). In contrast, the Serengeti plains and woodlands harbor a large outbred popu-

* Corresponding author.

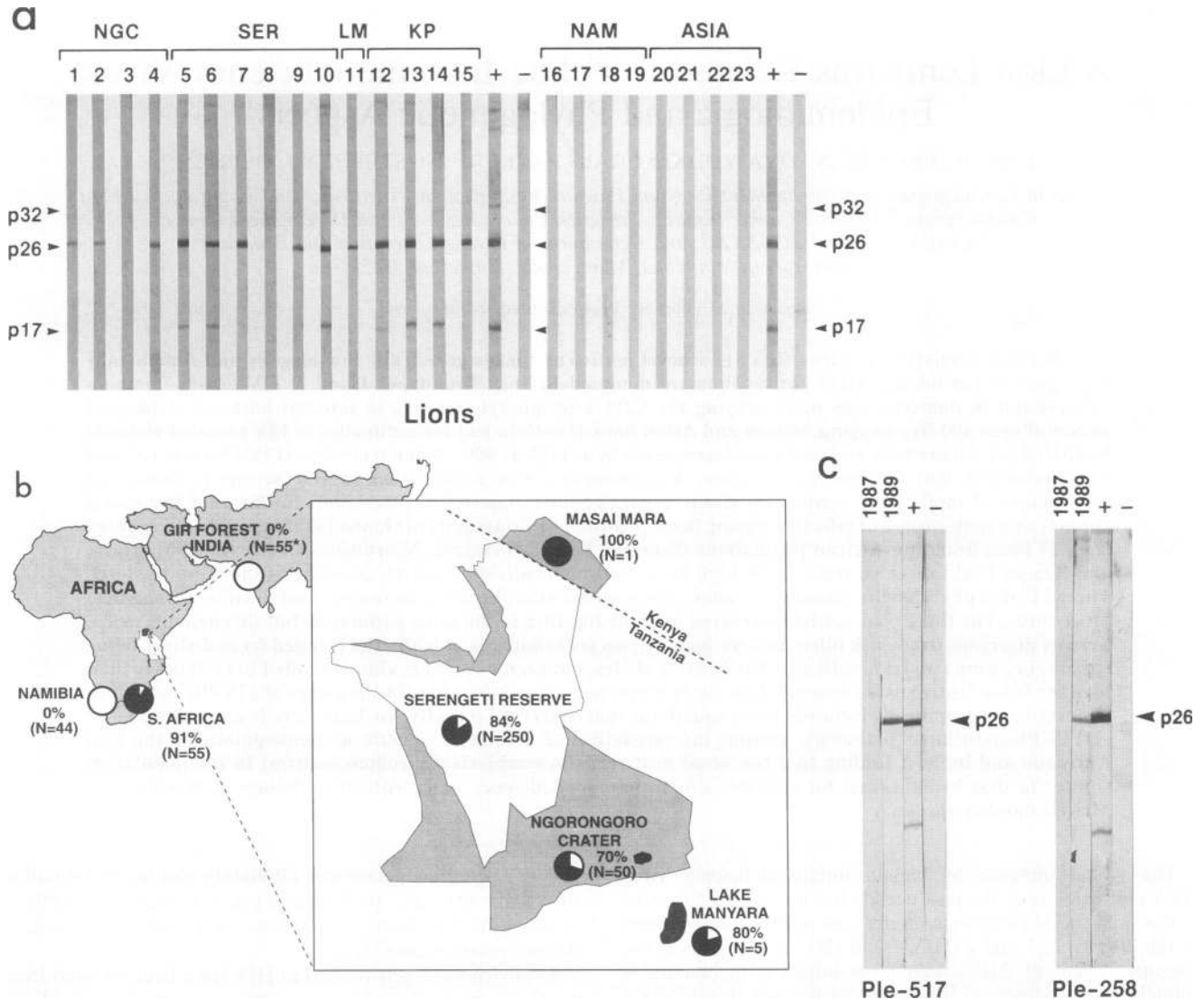

FIG. 1. Seroprevalence of cross-reactive antibodies to feline lentivirus in lions (*P. leo*). (A) Western blot analysis of selected lion serum and plasma samples from free-ranging populations. Lanes 1 to 4, lions Ple-276, Ple-298, Ple-300 (seronegative), and Ple-284, from the Ngorongoro Crater (NGC); lanes 5 to 10, lions Ple-481, Ple-468, Ple-457, Ple-387 (seronegative), Ple-458 (L75), and Ple-556, from the Serengeti ecosystem (SER); lane 11, lion Ple-325, from Lake Manyara (LM); lanes 12 to 15, lions Ple-173, Ple-174, Ple-180, and Ple-164, from Kruger Park (KP); lanes 16 to 19, lions Ple-443, Ple-446, Ple-429, and Ple-431, from Namibia (NAM), all seronegative; lanes 20 to 23, lions Ple-193, Ple-188, Ple-186, and Ple-187, from Asia, all seronegative; lanes + and -, control sera from FIV-positive and FIV-negative domestic cats, respectively. (B) Seroprevalence of a lion lentivirus LLV (FIV-Ple) in African and Asian free-ranging lions. The N value indicates the number of free-ranging animals screened from a given area. Lentivirus seroprevalence percentages are given in numerical and pie graph form. The 55 Indian lions from the Gir Forest include 6 wild-caught lions, 9 animals from the Sakkarbaug Zoo (denoted by the asterisk) in Junagadh that were captured from the Gir Forest sanctuary, and 40 captive-born lions from Sakkarbaug Zoo. All other lions are free-ranging animals. The Masai Mara is an extension, in Kenya, of the Serengeti ecosystem. The Ngorongoro Crater is an extinct volcanic caldera approximately 10 miles in diameter adjacent to the Serengeti. The lion population of approximately 100 animals is descended from 15 founders after a *Stomoxys* epizootic in 1962 (41). Lake Manyara has a small isolated lion population that is well-known because the lions sleep in the trees. The Gir Forest population consists of about 250 lions descended from a near extinction of the Asiatic lion subspecies *P. leo persica* due to overhunting at the turn of the 20th century (32, 53). Namibian lions are from Etosha Pan National Park. (C) Western blot analysis of serum samples from two adult male East African lions. Both lions were sampled in 1987 and in 1989. In lanes 1987, both Ple-517 and Ple-258 lack antibodies to FIV-PET. In lanes 1989, both lions reveal antibodies to the FIV major core protein p26. Ple-517 (PNE) and Ple-258 (Charlie) were both inhabitants of the Serengeti Wildlife Reserve, Tanzania. Lanes + and -, positive (FIV-infected) and seronegative control domestic cat sera, respectively.

lation of lions that reflects a high level of genetic diversity across the study area (32, 38).

The phylogenetic reconstruction of feline lentiviruses from domestic cats (FIV-Fca) and pumas (FIV-Pco), also called puma lentivirus (PLV), revealed species specificity among the

cat lentiviruses, with FIV-Pco isolates showing genetic divergences greater than those previously observed between the human lentiviruses and their nearest simian neighbors (26, 36, 44). In this report we summarize a widespread prevalence of exposure to lentiviruses cross-reactive to domestic cat FIV

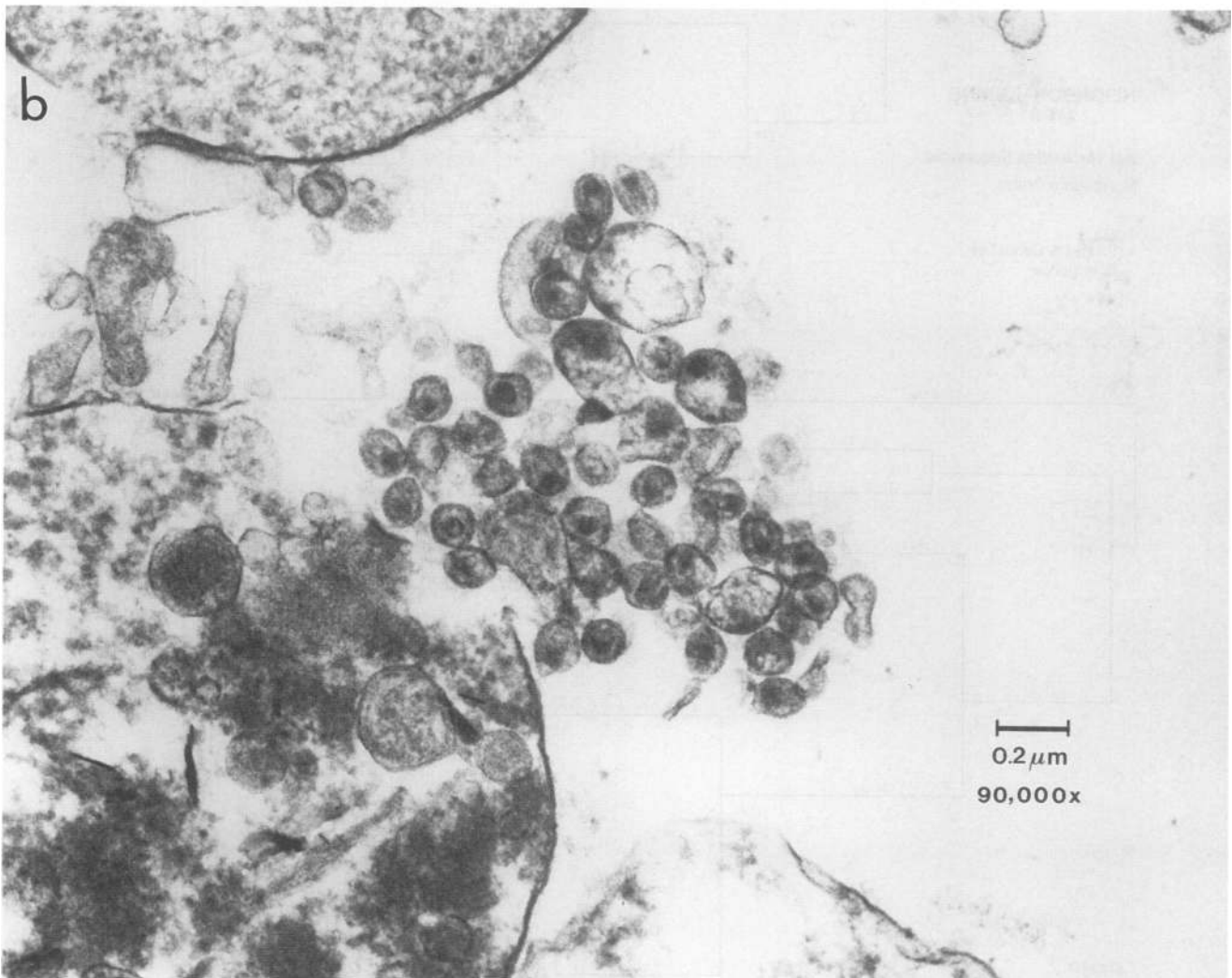
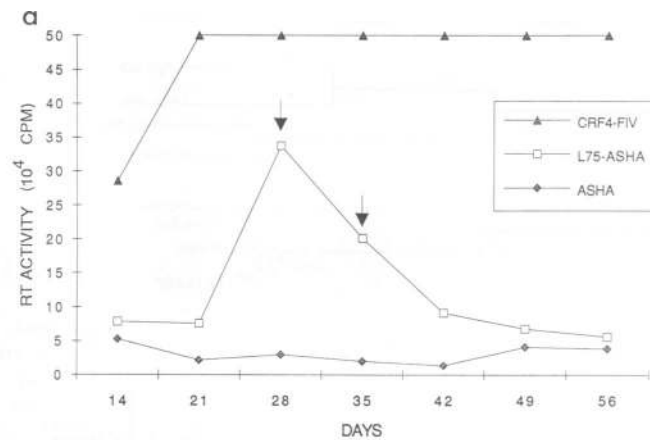
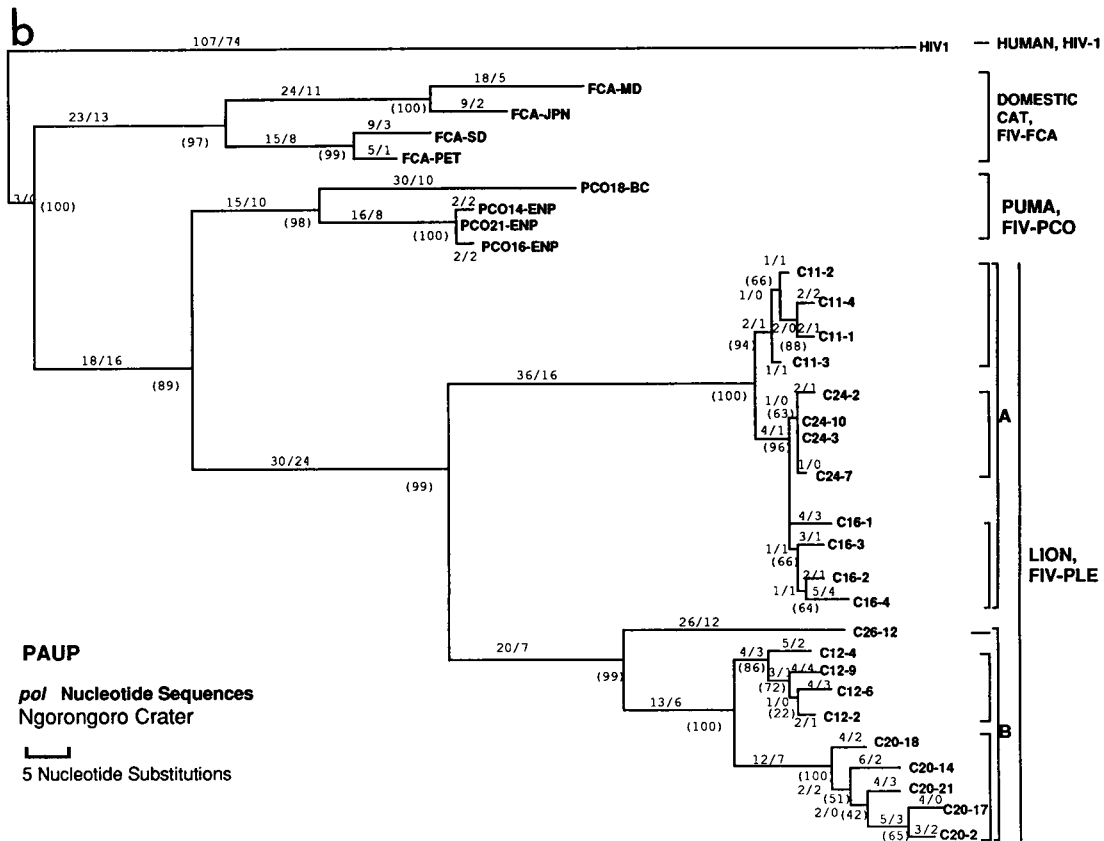
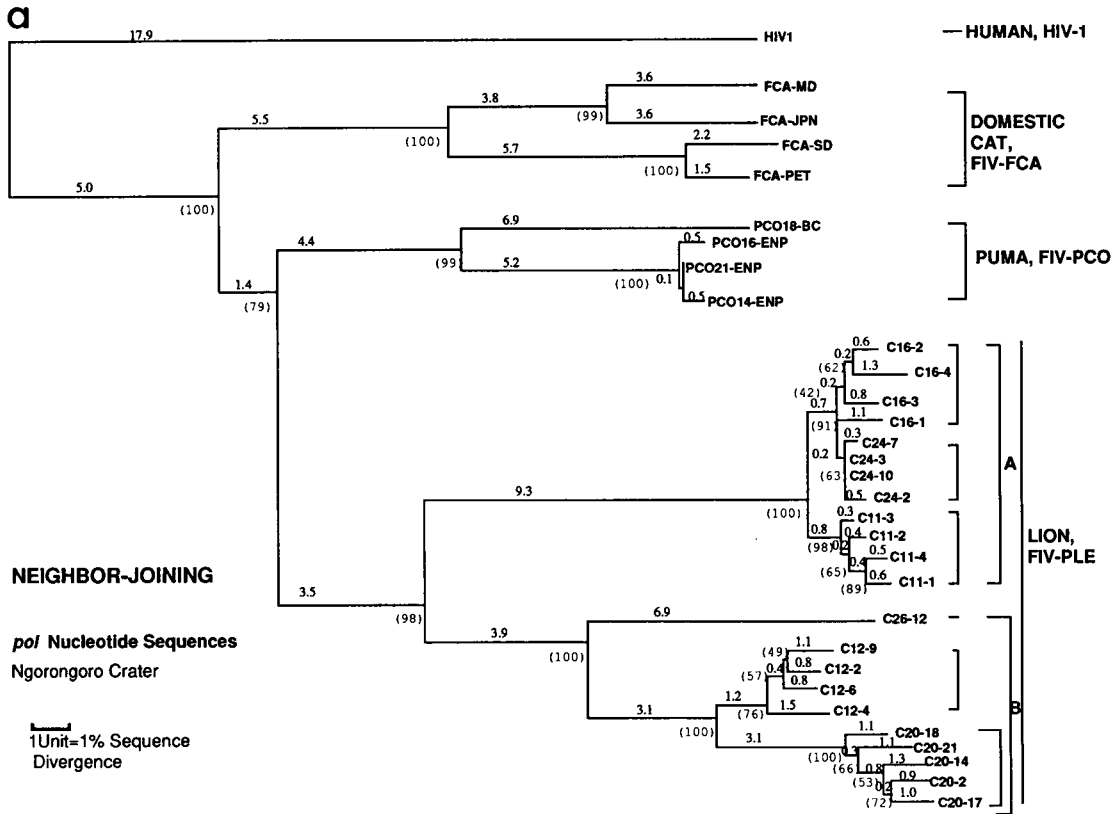

FIG. 2. Transmission of a lion lentivirus (FIV-Ple) to fresh lion PBMCs. (A) Production of magnesium-dependent RT activity for L75 (Ple-458)-Asha (Ple-73) PBMC coculture, Crf4-FIV, an FIV-infected positive control, and Asha PBMCs alone for baseline RT measurements. RT assays containing water in place of culture supernatants were also used for negative controls. The abscissa (x) is defined by days following cocultivation, while the ordinate (y) indicates the RT activity in scintillation counts per minute (CPM). The arrows indicate time points (days 28 and 35) when culture fluids were harvested and processed for electron microscopy. (B) Electron micrograph of mature lentivirus particles in zoo lion PBMCs cocultured with PBMCs from Serengeti lion L75.



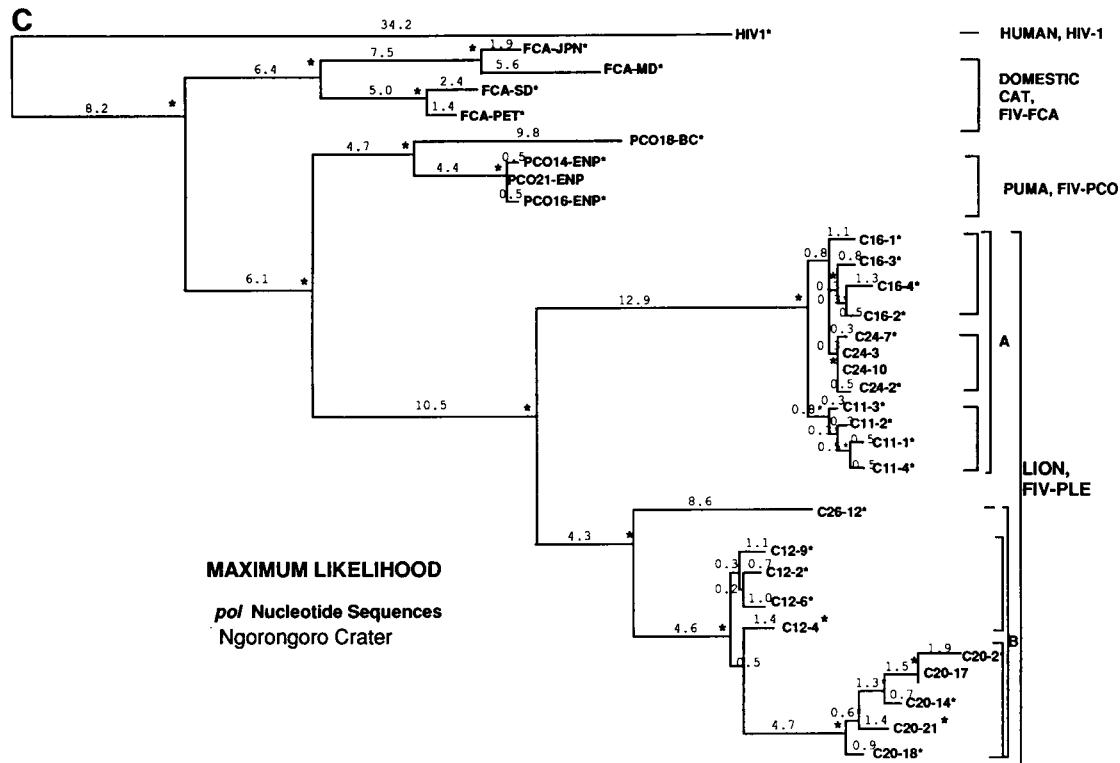
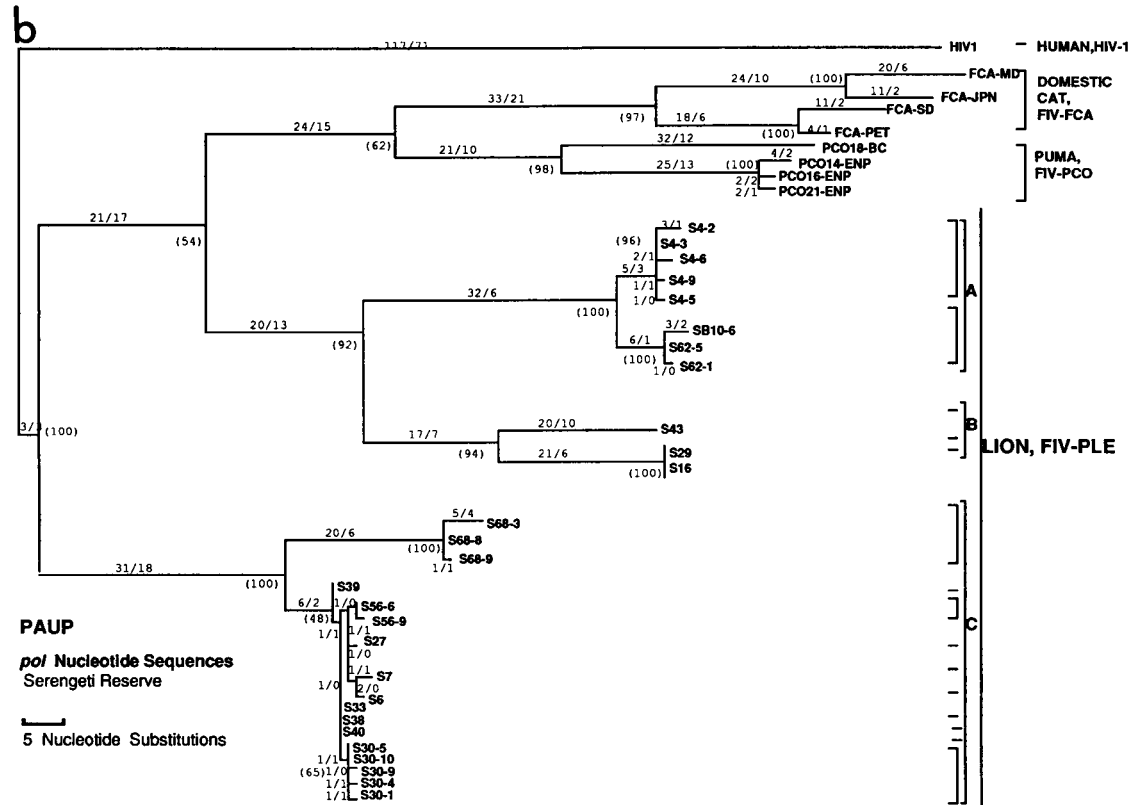
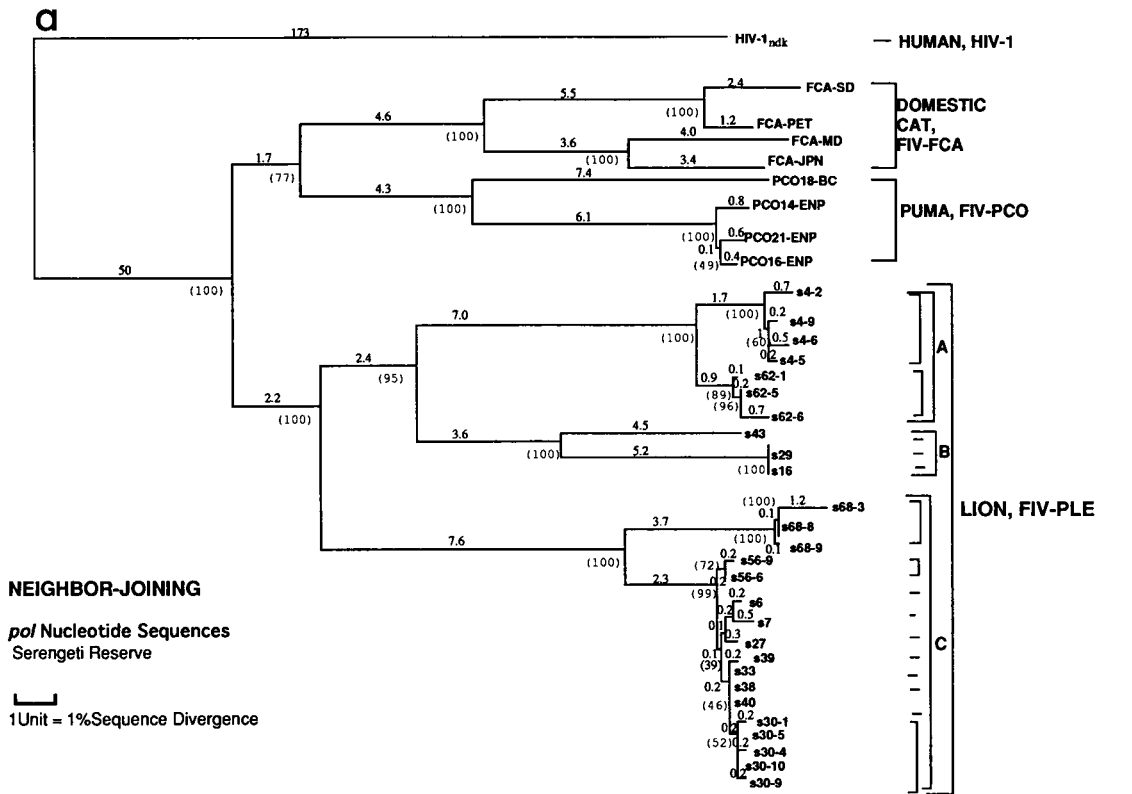

FIG. 3. Evolutionary trees of the 22 Ngorongoro Crater FIV-Ple *pol* sequences from six lions plus homologous FIV cat and puma sequences and HIV *pol* sequences. Each full-length sequence was aligned by using the PILEUP program of the Genetics Computer Group software package (11). Distances are expressed on the basis of percent nucleotide mismatches. (a) Neighbor-joining phenetic tree using a distance matrix based on the algorithm of Saitou and Nei (45) within the PHYLIP (phylogenetic inference package) program, version 3.51c (14). The numbered branch lengths are the percent nucleotide divergence between proviral sequences. In parentheses are the percentages of bootstrap iterations (of 100) that support the adjacent node. Brackets indicate sequences from individual lions and from clade groups. (b) Phylogenetic tree derived from the PAUP (phylogenetic analysis using parsimony) program, version 3.0 (50). A strict bootstrap consensus tree based on a midpoint root and on stepwise addition is shown. The branch lengths are presented as the number of nucleotide substitutions (preceding the shell) along with the number of unambiguous substitutions (following the shell). The number of unambiguous sites is equal to branch length minus the substitutions exhibiting homoplasy. The tree shown has an overall length of 521 changes and a consistency index of 0.70, indicating a 30% convergence level. Bootstrap values (of 100 iterations) are given in parentheses in support of each node. (c) Maximum likelihood tree generated by the DNAML program of the PHYLIP package (14). The final phylogeny of this tree was based on the most likely topology to emerge from the examination of 6,387 trees. The tree was generated by using a transition/transversion ratio of 2. Branch lengths are estimates of substitutions relative to the tree and are shown as 100 times the expected number of substitutions per site. Branch lengths not significantly different from zero were collapsed into polytomies. Asterisks indicate significant support ($P \leq 0.01$) for adjacent divergence node. The ln likelihood for the presented tree is $-2,967.80$. All trees were rooted with HIV-1 as the outgroup. The number immediately following the virus species abbreviation (e.g., FIV-Ple) represents an animal number, while hyphenated suffixes represent different molecular clones from PCR products of the same lion. The bracketed letter sequence clusters (A, B) denote phylogenetic clades or lineages (see text). The NDK strain of HIV-1 is shown here and was used in all analyses. Virus abbreviations: FIV-Fca, feline immunodeficiency virus (from domestic cat, *Felis catus*); FIV-Pco, feline immunodeficiency virus (from puma, *Puma concolor*); FIV-Ple, feline immunodeficiency virus (from lion, *Panthera leo*). Geographical abbreviations: C, Ngorongoro Crater lions; S, Serengeti reserve; LM, Lake Manyara; KP, Kruger Park; ENP, Everglades National Park pumas; BC, Big Cypress Swamp pumas; MD, Maryland; JPN, Japan; SD, San Diego; PET, Petaluma, CA.

(FIV-Fca) in 409 lions from seven wild populations located in eastern Africa, in southern Africa, and in Asia. Included in sampled populations were lions from the large Serengeti population ($n = 3,000$ lions), two populations with a history of demographic contraction followed by inbreeding (the Ngorongoro Crater population in Tanzania and that of the Gir Forest Sanctuary in western India), and populations from western and eastern regions of southern Africa (29, 30, 32–34, 41, 53).

To describe the phylogenetic relationship between lentivirus sequences within infected lions, between lions of the same population, and between geographically isolated populations, we determined the sequence of the reverse transcriptase (RT) domain of the slowly evolving *pol* gene from multiple lion

lentivirus (FIV-Ple) isolates by using PCR-amplified DNA from frozen leukocytes of representative individuals. A phylogenetic analysis revealed several general trends, namely: (i) monophyly of viral quasisppecies within individual lions, supportive of a clonal expansion of infections; (ii) the occurrence of three very deep ancestral clusters (phylogenetic clades) of FIV-Ple which were as different from each other as is domestic cat FIV (FIV-Fca) from puma lentivirus (FIV-Pco) (36); (iii) the occurrence of divergent clades within the same populations but not (so far) in the same individuals; and (iv) the evolutionary association of the three FIV-Ple clades somewhat more recently than the divergence nodes of all lion sequences from other felid lentiviruses (FIV-Fca, FIV-Pco), suggesting that FIV-Ple likely evolved in allopatric (geographically isolated)



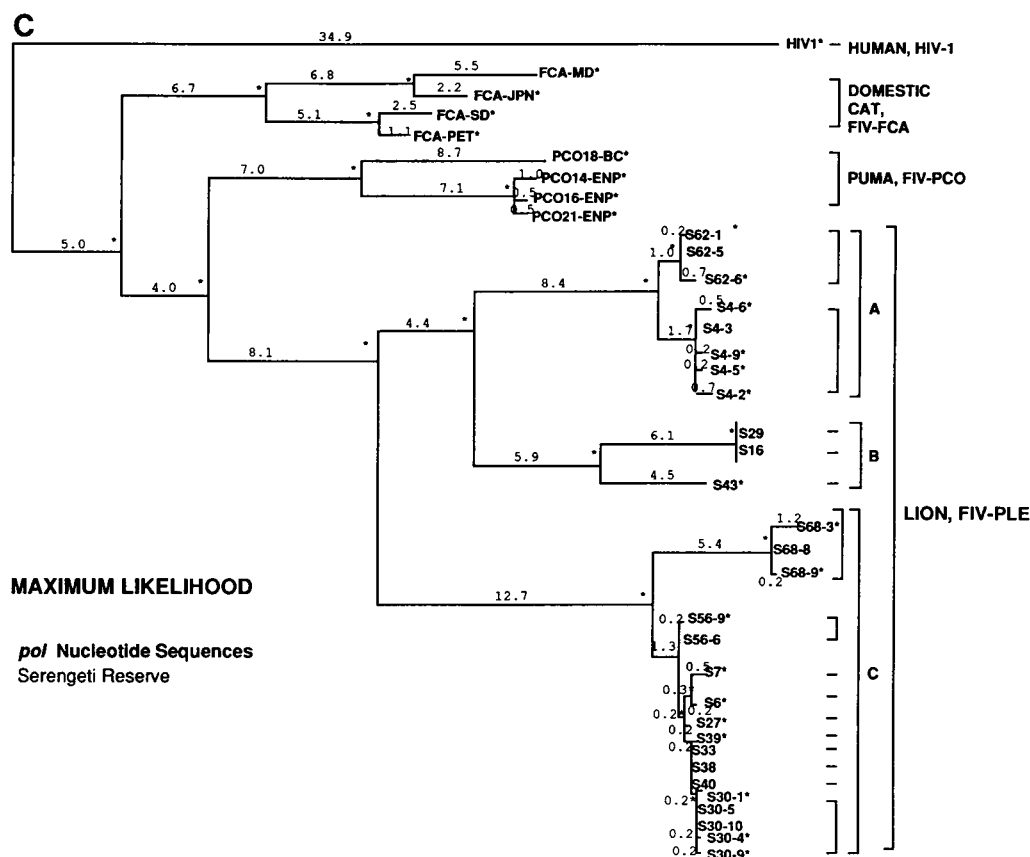

FIG. 4. Evolutionary trees of the 28 Serengeti FIV-Ple sequences from 15 lions and other feline and human lentivirus *pol* genes. Sequences were aligned as described in Materials and Methods. (a) Neighbor-joining phenetic tree using distance matrix as described in the legend to Fig. 3 (45). Branch lengths reflect percent nucleotide divergence. In parentheses are the numbers of bootstrap iterations (of 100) that support the adjacent node. (b) PAUP maximum parsimony tree (50). The strict bootstrap consensus tree presented here has an overall length of 580 changes and a consistency index of 0.65, yielding a 35% convergence level. The scale and branch lengths are presented as the number of nucleotide substitutions (preceding the shall) with the number of unambiguous substitutions (following the shall). An unambiguous site is equivalent to the branch length minus the homoplasy. Bootstrap values (of 100 iterations) are in parentheses. (c) Maximum likelihood tree from DNAML (14). This tree phylogeny was based on the most statistically significant tree of 12,609 trees examined. This tree was generated using a transition/transversion ratio of 2. Branch lengths are substitutions, relative to the tree shown, shown as 100 times the expected number of substitutions per site. Branch lengths not significantly different from zero were collapsed into polytomies. Asterisks indicate significant support ($P \leq 0.01$) for adjacent divergence node. The ln likelihood for the presented tree is $-3,217.38$. See legend to Fig. 3 for geographic and virus abbreviations.

populations of lions rather than in another felid species, with subsequent and recent transfer to lions. These findings are consistent with the presence of FIV-Ple in some, but not all, lion populations for a long period, possibly as far back as species divergence of the genus *Panthera* (the great cats: lion, tiger, leopard, snow leopard, and jaguar) (52).

(The work reported in this article is in partial fulfillment of requirements for the degree of Master of Science for Eric W. Brown from the Department of Biology, School of Graduate Studies, Hood College, Frederick, Md.)

MATERIALS AND METHODS

Western immunoblot analysis. Serum/plasma and peripheral blood mononuclear cell (PBMC) samples from 409 free-ranging lions were collected from natural populations or wildlife reserves across Africa and Asia from 1983 to 1992 (16, 30, 32, 39, 41). Positive control serum was obtained from experimentally infected cats or seropositive lions, while negative serum came from seronegative cats. Lion serum/plasma

samples were tested against FIV-Petaluma domestic cat viral antigens for the presence of cross-reactive antibodies by Western blot as previously described (7, 8, 37).

Samples were collected in full compliance with specific federal fish and wildlife permits (Convention on International Trade of Endangered Species) issued to the National Cancer Institute, principal officer S. J. O'Brien, by the U.S. Fish and Wildlife Service of the Department of the Interior.

Isolation of a lentivirus from lion PBMCs. Heparinized blood was obtained intravenously from free-ranging seropositive Serengeti lions, and the PBMCs were then extracted and purified within 24 h of bleeding by sucrose gradient centrifugation using Histopaque (Sigma). PBMCs from Serengeti lions (10^6 cells) were stimulated by concanavalin A ($5 \mu\text{g/ml}$) for 72 h and were cultured with mitogen-stimulated donor PBMCs (10^6 cells) from a captive zoo lion that had repeatedly tested negative for virus isolation. Cocultures were propagated in RPMI 1640 with 10% fetal bovine serum and 10% human interleukin-2 (Gibco-BRL). Fresh medium was added every 72 h along with fresh donor cells (10^6) every 14 days. Coculture

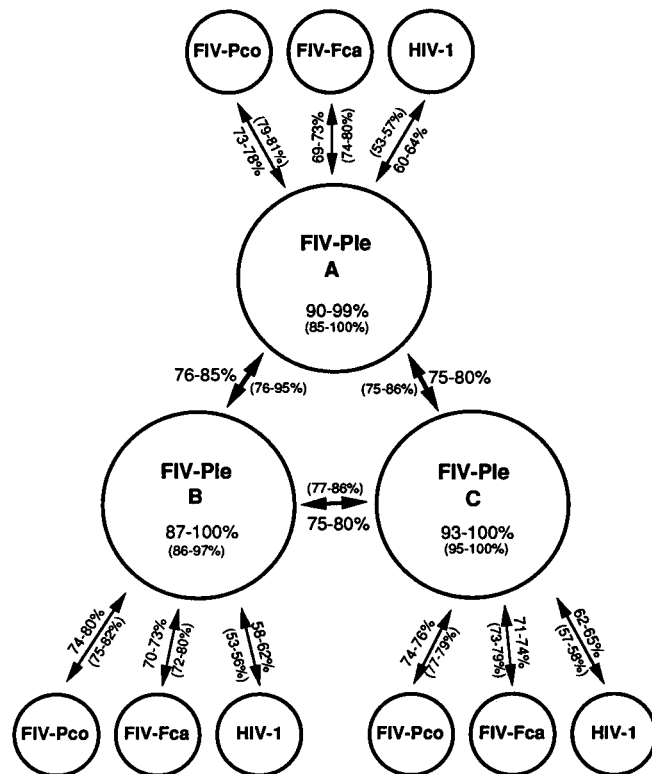

FIG. 5. Schematic showing the minimum and maximum percent nucleotide sequence identities within and between the three major FIV-Ple clades as well as between the FIV-Ple clades and other feline and human lentiviruses. The clade letter designations of the three FIV-Ple clades are present within the large circles (A, B, and C). Minimum-maximum percent sequence identities within each of the three FIV-Ple clades are listed within each clade. Minimum-maximum percent sequence identities between various clades or species are listed along the arrows that designate the viruses being compared. Minimum and maximum percent amino acid similarities are also listed in parentheses within clades, between clades, and between feline and human lentiviruses. Virus abbreviations are as listed in the legend to Fig. 3.

supernatants were clarified by low-speed centrifugation and were examined weekly for the presence of replicating virus by Mg^{2+} -dependent RT assays performed essentially as described previously (6). Infectious supernatant from a Crandall feline kidney monolayer chronically infected with FIV-Petaluma (Crf4) was used as a positive control for RT assays, while supernatant from cultured seronegative lion PBMCs was used to monitor RT baseline activity. During the period of maximal RT activity, culture supernatants were harvested and surveyed by electron microscopy for the presence of lentivirus particles.

Amplification of the proviral *pol* gene from leukocytes of lion lentivirus-infected animals. Genomic DNAs were isolated from the PBMCs of 27 seropositive lions, and DNA concentrations were adjusted to 0.25 $\mu\text{g}/\mu\text{l}$. The segment of the RT region from the proviral *pol* gene (FIV-Petaluma coordinates bp 2403 to 3042) was amplified by PCR from 0.25 to 0.50 μg of genomic DNA stocks. PCR reactions were set up in 50- μl volumes and were prepared according to conditions outlined in the user's manual of *Taq* DNA polymerase (Perkin-Elmer Cetus) with 1.5 U of *Taq* polymerase per reaction. Thermal cycles were performed in a Perkin-Elmer 9600 under the

following conditions: 94°C 3-min burst, followed by 35 cycles each at 94°C (15-s bursts), 45°C (28-s bursts), 72°C (15-s bursts), ending with a 72°C 10-min extension. Seropositive lions and experimentally infected domestic cat PBMC DNAs were used for positive controls, and PBMC DNAs from seronegative lions, negative domestic cats, DNA from other species, and reactions with no templates were used for negative controls. Oligonucleotide primer sequences and the base-pair positions on the FIV-PET (36) genome are 1258F (bp 2430), 5'GAAGCATTAACAGAAATAGTAG3'; 1260R (bp 3007), 5'GTTCTTGTGTAATTTATCTTC3'; 1259F (bp 2466), 5'GAAGGAAAGGTAAGGAGCAGATC3'; 1261R (bp 2990), 5'ATCTTCAGGAGTTTCAAATCCCCA3'; 6635F (bp 2511), 5'CCTATATTTGCATTAAGG3'; 6637R (bp 2944), 5'ACCCATATGATATCATCC3'; 6636F (bp 2529), 5'AAAGAATCAGGAAAATATA3'; 6638R (bp 2934), 5'GATATCATCATATATTGATAT3'. Nested primers 1258F, 1260R, 1259F, and 1261R were used to amplify all of the Serengeti FIV-Ples as well as Ngorongoro Crater lion sequences C12, C20, and C26. Nested primers 6635F, 6637R, 6636F, and 6638R were used to amplify C24, C16, C11, LM3, and LM4. Primers 1259F, 1261R, 6635F, and 6637R were used to amplify the Kruger Park sequences. The 1200-numbered primers were designed from the alignment of FIV-Fca and FIV-Pco isolates from Florida panthers (37). The 6600-labeled primers were made from the alignment of Serengeti lion S4 and S62 sequences and represent highly conserved regions of the RT molecule that are shared across lion, puma, and domestic cat FIV sequences.

Molecular cloning and sequence determination. Products from PCR amplification of lion leukocyte DNA were column purified and ligated to a sticky-T cloning vector previously prepared by attaching a single dTTP to the blunt end of a (KS+) phagemid (Stratagene). Products were ligated overnight, and reactions were transformed into an NM522 cloning strain by conventional heat-shock methods (37). Three-milliliter overnight cultures were prepared from 10 clones, and phagemids were then harvested in ion-exchange columns (Qiagen). Multiple phagemid clones were then sequenced by Sanger chain-termination methods on an ABI 373A automated sequencer (Applied Biosystems Inc.). M13 and T3/T7 primer binding sites were used to initiate forward- and reverse-strand reactions. For lions S6, S7, S27, S33, S38, S39, S40, S16, S29, and S43 oligonucleotide primers containing M13 universal primer sequences were used with the first-round PCR products to yield a final product that was then sequenced directly. All sequence data were then transferred into the VAX/GCG (11) sequence handling program, and full-length fragments were assembled.

Phylogenetic reconstruction. Nucleotide sequences from the Serengeti, Tanzania, were subjected to phylogenetic analyses by using a total of 421 bp of nucleotide sequence which, when translated, yielded 139 amino acid residues. Shorter sequences from the Ngorongoro Crater (375 bp, 124 amino acids) and representative sequences (368 bp, 122 amino acids) from the Serengeti, Ngorongoro, Lake Manyara, Tanzania, and Kruger Park, South Africa were also analyzed. Sequences were aligned by the GAP program of the Genetics Computer Group (University of Wisconsin) computer software package (11, 28). Distances are expressed on the outcome of percent nucleotide sequence identity. Gaps were given a weight equivalent to a single nucleotide substitution, regardless of length. Three different phylogenetic algorithms were used. The phenetic algorithm Neighbor-joining, was available through PHYLIP version 3.51c (14, 45). The second method utilizes the principle of maximum parsimony, available in PAUP version 3.0 (50, 51). The third procedure employed the maximum likelihood

approach, available in DNAML in PHYLIP (14). Phenetic (distance matrix based) and maximum parsimony analyses were also performed on the representative FIV-Ple amino acid sequences from all geographic locales.

Nucleotide sequence accession numbers. The nucleotide sequence data reported in this paper have been deposited into the GenBank sequence database under the following accession numbers: U06010 (llvc11-1), U06011 (llvc11-2), U06012 (llvc11-3), U06013 (llvc11-4), U06014 (llvc12-2), U06015 (llvc12-4), U06016 (llvc12-6), U06017 (llv12-9), U06018 (llvc16-1), U06019 (llvc16-2), U06020 (llvc16-3), U06021 (llvc16-4), U06022 (llvc20-14), U06023 (llvc20-17), U06024 (llvc20-18), U06025 (llvc20-2), U06026 (llvc20-21), U06027 (llvc24-10), U06028 (llvc24-2), U05990 (llvc24-3), U05991 (llvc24-7), U05992 (llvc26-12), U06029 (llvs4-2), U06030 (llvs4-3), U06031 (llvs4-5), U06032 (llvs4-6), U06033 (llvs4-9), U06043 (llvs62-1), U06044 (llvs62-5), U06045 (llvs62-6), U06036 (llvs56-6), U06037 (llvs56-9), U06039 (llvs68-3), U06040 (llvs68-8), U06041 (llvs68-9), U06002 (llvs30-1), U06003 (llvs30-10), U06004 (llvs30-4), U06005 (llvs30-5), U06006 (llvs30-9), U06034 (llvs40), U06035 (llvs43), U06038 (llvs6), U06042 (llvs7), U05999 (llvs16), U06000 (llvs27), U06001 (llvs29), U06007 (llvs33), U06008 (llvs38), U06009 (llvs39), U05997 (llvlm3-9), U05998 (llvlm4-1), U05993 (llvlp153-10), U05994 (llvlp165-8), U05995 (llvlp175-8), and U05996 (llvlp177-9).

RESULTS

Serological incidence of FIV-related lentiviruses in lions. Plasma samples from 406 lions were typed by Western blot for antibodies to feline lentiviruses antigenically related to FIV (Fig. 1a). The serological status for FIV cross-reacting antibodies of free-ranging African and Asian lions from seven populations is presented in Fig. 1b. As previously reported (7, 8, 37), exposure to FIV-related lentiviruses appears to be endemic in East African lion populations. The incidence of seropositive lions was 84% in the Serengeti, 70% in the Ngorongoro Crater, 80% in Lake Manyara, and 91% in Kruger Park. Two lion populations, Asiatic lions from India and African lions from Etosha Pan in Namibia, were all seronegative (Fig. 1a and b) (8, 37).

Natural seroconversion (transition from antibody-negative to -positive) in two East African male lions was observed (Fig. 1c). Multiple serum samples were drawn from these two individuals in different years. At the first sampling date in 1987, both animals were seronegative, but by 1989 each animal possessed antibodies to the major FIV core protein (p26). These findings affirm that, like domestic cat FIV (54), a lion lentivirus (FIV-Ple) is being transmitted horizontally within the species, possibly through bites during fighting. A comparison of FIV antibody status in parents with that in cubs was possible, as we had previously established the parentage of 72 cubs by using feline-specific DNA fingerprints (16, 39). Eighteen percent (20 of 113) of cubs born to seropositive dams tested seronegative, and 20% (7 of 30) of cubs produced by two seropositive parents also were antibody negative. Five separate litters born to infected mothers were documented as having at least one seronegative cub, while two of these litters ($n = 3$ cubs per litter) were entirely free of FIV-Ple exposure. Conversely, 77% (7 of 9) cubs born to seronegative dams tested seropositive. The parent-cub discordance would suggest that horizontal transmission and not maternal infection is the primary route of transfer between free-ranging lions.

Isolation of lentivirus particles from lion PBMCs. PBMCs from five seropositive Serengeti lions were cultured with

donor PBMCs from Asha (Ple-73), a captive lion from The National Zoological Park, Washington, D.C. The supernatant from one lion, L75 (Ple-458), resulted in elevated magnesium-dependent RT activity (338,000 cpm) at 28 days (Fig. 2a), indicating that a replication-competent retrovirus was transferred to the fresh PBMCs. A second coculture of fresh L75 lymphocytes was repeated; it also tested positive for RT activity. At the peak of RT activity, electron microscopic examination of the L75-Asha coculture supernatants (Fig. 2b) revealed the presence of individual virus particles with lentivirus morphology, including a bar-shaped cylindrical core characteristic of the primate lentiviruses. These lion lentivirus particles likely originated from L75, since Asha lymphocytes, although antibody positive for FIV p26, remained consistently RT and virus isolation negative when cultured with lymphocytes from two different seronegative lions and alone. Virus isolation from other lions was unsuccessful (Fig. 2a).

Phylogenetic characterization of FIV-Ple from Ngorongoro Crater lions. The nucleotide sequence of a 375-bp amino-terminal segment of the FIV-Ple *pol* gene was first determined from molecular clones of PCR-amplified products from lymphocyte DNA samples of six infected Ngorongoro Crater lions. The aligned nucleotide sequences of the Ngorongoro FIV-Ples were compared with FIV-Pco (PLV), FIV, and HIV-1.

The Ngorongoro Crater FIV-Ple sequences were analyzed by using three different phylogenetic approaches: phenetic or distance matrix based, maximum parsimony, and maximum likelihood. The derived phylogenetic trees revealed several important aspects (Fig. 3). First, in almost all cases the trees were topologically equivalent, irrespective of the phylogenetic method employed. The only exceptions involved the relative positions of multiple clones from a single lion. Second, in every case, clones from a single lion exhibited monophyly with respect to their host; that is, each clone sequence had another clone from the same lion as its nearest relative. Third, two very divergent phylogenetic lineages or clades, designated clades A and B, were resolved. The two clades appear among lions in the same small population. Lions C12 and C26 were inhabitants of the same pride, as were C24 and C11, with the two FIV-Ple clades spanning four prides overall in the Ngorongoro Crater. Fourth, the extent of sequence divergence between the two FIV-Ple clades (20 to 24% for nucleotide sequences and 10 to 18% for amino acid sequences) was large, on the order of the genetic distances between homologous *pol* regions observed for highly divergent geographic isolates of puma lentivirus, FIV-Pco (maximum 25% nucleotide sequence divergence; Fig. 3a) (37); the divergence was twice that previously reported for FIV (FIV-Fca) *pol* sequence variation (maximum 16% nucleotide divergence and 11% amino acid sequence divergence). FIV-Ple clade divergence exceeds the divergence in the homologous *pol* region between HIV-2 and SIV-SM (17% nucleotide sequence divergence and 10% amino acid divergence) and in the homologous *pol* region between HIV-1 and SIV-CPZ (19% nucleotide divergence and 6% amino acid sequence divergence); further, the extreme divergence in FIV-Ple clades approaches the *pol* sequence difference observed between HIV-1 and HIV-2 (30% nucleotide difference and 28% amino acid difference).

Phylogenetic characterization of FIV-Ple from Serengeti lions. The nucleotide sequences from 421-bp segments of the *pol* gene from 15 seropositive lions collected from the large outbred Serengeti population were collected and aligned for phylogenetic analysis. The Serengeti FIV-Ple sequence data were analyzed by the same three phylogenetic methods (Fig. 4). Multiple cloned sequences were taken from the following Serengeti lions: S4, S62, S56, S30, and S68. As was seen with

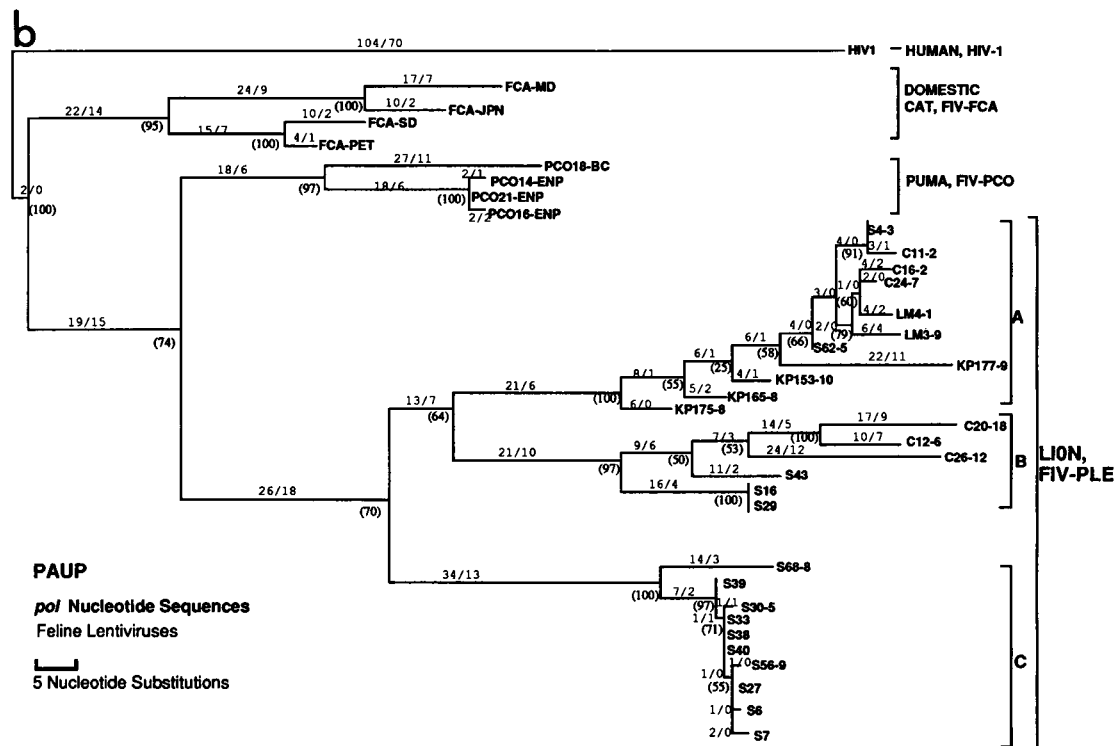
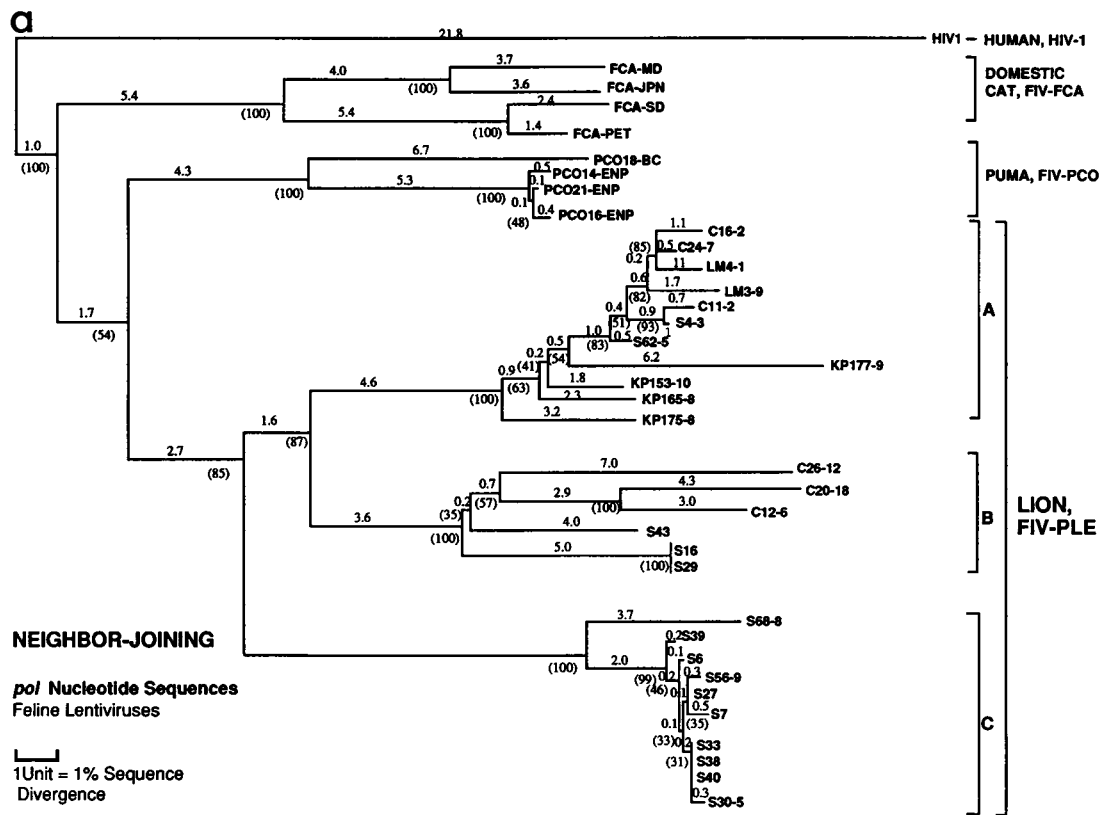

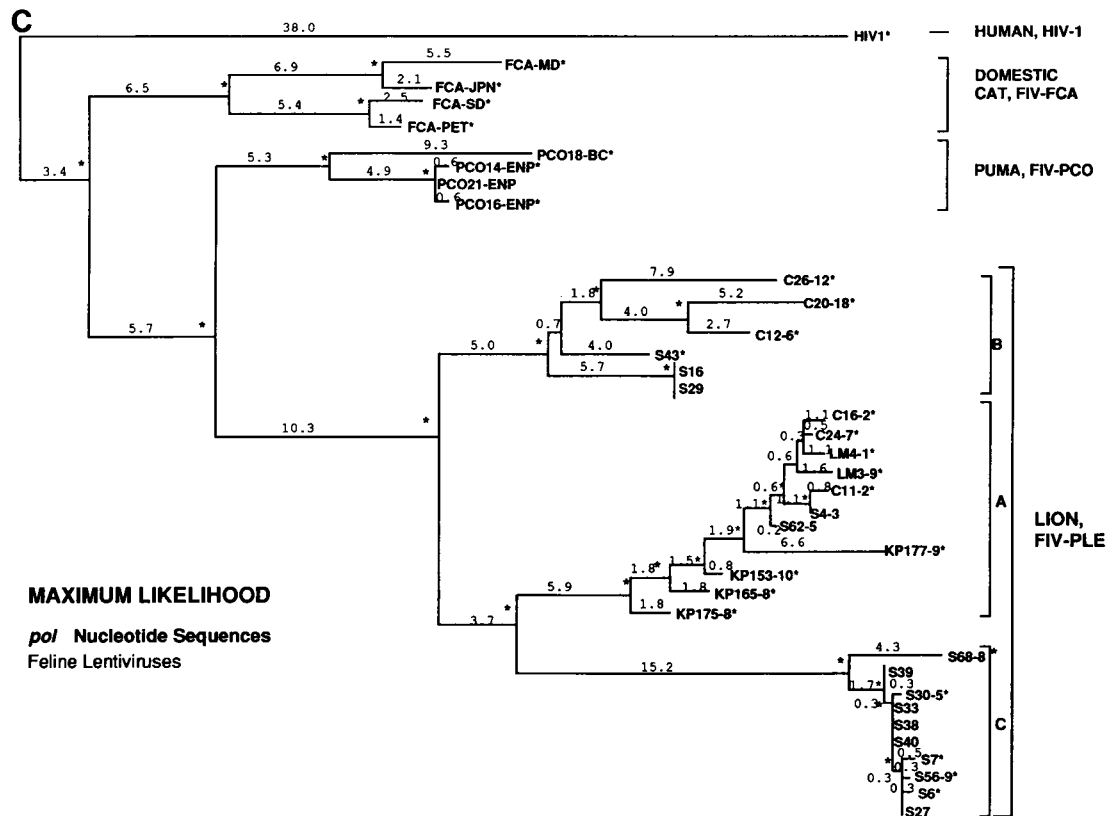

FIG. 6. Phylogenetic trees of the 27 representative African FIV-Ple nucleotide sequences along with other feline and human lentivirus *pol* sequences. (a) Neighbor-joining tree based on the distance matrix described in the legend to Fig. 3 (45). Branch lengths reflect the percent nucleotide divergence. In parentheses are the number of bootstrap replications (of 100) in support of the adjacent node. (b) PAUP maximum parsimony tree. This strict bootstrap consensus, based on a midpoint root and on stepwise addition, has an overall branch length of 634 substitutions and a consistency index of 0.60, indicating a 40% convergence level. Branch lengths are expressed as the number of nucleotide substitutions along with the number of unambiguous substitutions (branch length minus homoplasy). Bootstrap values (of 100 iterations) are presented. (c) Maximum likelihood tree. This topology was determined from 11,360 trees examined. This tree was generated by using a transition/transversion ratio of 2. Branch lengths are estimates of substitutions and are shown as 100 times the expected number of substitutions per site. Branch lengths not significantly different from zero are collapsed into polytomies. Asterisks indicate significant support ($P \leq 0.01$) for adjacent divergence node. The ln likelihood for the presented tree is $-3,467.66$. All trees were rooted with HIV-1 as an outgroup. See legend to Fig. 3 for a complete description of the methods used and for virus and geographic abbreviations.

samples from lions from the Ngorongoro Crater, all of the cloned segments from within the same individual are monophyletic, suggesting clonal expansion of the infecting virus followed by the evolution of quasispecies. The two divergent lion clades, A and B, observed with lions from the Ngorongoro Crater were also evident for the Serengeti lions. However, a third sequence clade, designated clade C, also appeared. Clade C sequences show a greater divergence from those of either clade A or clade B than exists between clade A sequences and clade B sequences. Further, the nucleotide divergence (26%) between clade C sequences and those of the other two lion lentivirus (FIV-Ple) clades appears to be greater than any distances previously described for domestic cat lentivirus (FIV-Fca) or puma lentivirus (FIV-Pco) isolates (36, 37).

Phylogenetic characterization of FIV-Ple from all geographic locales. We have analyzed a single representative FIV-Ple sequence from each of 27 lions examined from throughout their African range, along with FIV-Fca, FIV-Pco, and HIV-1. Sequences from 6 Ngorongoro lions, 15 Serengeti lions, 2 Lake Manyara lions, and 4 Kruger Park lions were included in the analysis. The minimum and maximum percent nucleotide sequence identities between the three FIV-Ple

clades are shown in Fig. 5 along with the percent sequence identity between each lion clade and FIV-Fca, FIV-Pco, and HIV-1.

Phylogenetic analysis of the FIV-Ple sequences using three phylogenetic methods led to the following observations (Fig. 6). First, the three FIV-Ple clades were found throughout the range of African lions. Bootstrap support for the three clades was very strong (100% for each with Neighbor-joining and 97 to 100% for maximum parsimony (Fig. 6a and b), as was seen in Serengeti (Fig. 4a and b) and Ngorongoro Crater (Fig. 3a and b) FIV-Ple phylogenetic analyses. The topology of the trees was consistent for all methods applied, with the exception of the maximum-likelihood algorithm, which placed clade B as the ancestral clade among the three. Clade A FIV-Ple viruses were present in three contiguous East African lion populations of the Serengeti, Ngorongoro, and Lake Manyara as well as in lions from Kruger Park, South Africa. Clade B FIV-Ple sequences were found in the Ngorongoro Crater and the Serengeti, while clade C was unique to the Serengeti FIV-Ples. Second, the nodes adjoining the three FIV-Ple clades appear to be very deep, displaying a unique trichotomy of sequence divergence. Third, the maximum divergence observed between

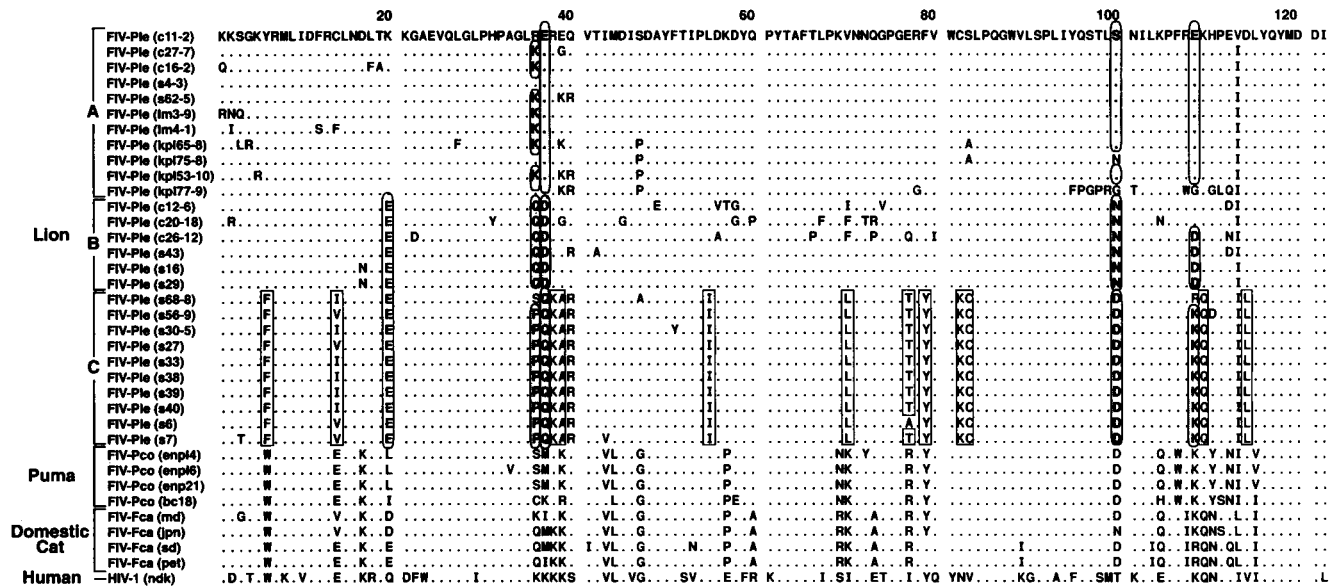

FIG. 7. Alignment of the predicted amino acid sequences of a conserved RT domain in the FIV-Ple, FIV-Pco, FIV-Fca, and HIV-1 *pol* genes (11, 28). Dots below the reference sequence indicate identical amino acids. FIV-Ple lineages are denoted A, B, and C at the left along with labels indicating puma, domestic cat, and human. The alignment contains representative amino acid sequences from FIV-Ple sequences from all geographic locales and from other feline and nonfeline lentiviruses. The shaded ovals indicate the shared derived characters, signature synapomorphies, that are unique to each of the three FIV-Ple clades, while the open oval indicates the synapomorphic residue that distinguishes clades B and C from clade A, while the open rectangles denote those residues that distinguish clade C from the other two clades. See legend to Fig. 3 for virus and geographic abbreviations.

the three FIV-Ple clades surpasses the genetic distances between domestic cat FIVs and puma FIV-Pcos (Fig. 5 and 6a). Finally, the FIV-Ple sequence clades appear to be monophyletic with respect to lions, such that any FIV-Ple sequence clade has as its nearest neighbor another FIV-Ple sequence clade.

Analysis of FIV-Ple *pol* amino acid sequences from all locales. The FIV-Ple nucleic acids were translated by computer (11), and the resultant amino acid sequences of representative FIV-Ples from all geographic locales have been analyzed. The aligned amino acid sequences of this data set are presented in Fig. 7. Immediately, it became apparent that there are very clear regions across the RT domain in which variation is permitted. Conversely, there appear to be regions that do not change and that may be functionally constrained. These conserved regions demonstrate homology across all feline lentiviruses including HIV-1 (Fig. 7). Further, there appear to be shared residues present in the FIV-Ple amino acid alignment that are unique to a given FIV-Ple clade. These shared derived characters, or signature synapomorphies, are present in several positions across the RT region. Synapomorphic residues at positions 36-37, 100, and 108 are unique in each of the three FIV-Ple clades, while residues 6, 14, 20, 38 to 39, 55, 70, 77, 79,

82-83, and 114 distinguish clade C from the other two groups (Fig. 7). Furthermore, a single synapomorphy at residue 20 distinguishes clades B and C from clade A (Fig. 7).

The phylogenetic reconstruction of the *pol* amino acid sequences was derived with the Neighbor-joining and PAUP algorithms (45, 50). The evolutionary trees derived from these analyses are presented for the total FIV-Ple datum set in Fig. 8. The *pol*-based amino acid trees recapitulate the topologies of the major FIV-Ple lineages, A, B, and C, which were described with the nucleotide trees. However, the topology of several of the branch tips of the amino acid trees varies from that observed in the nucleotide analysis, possibly demonstrating the divergence plateau that these sequences may have reached due to the functional selection constraints of the RT molecule (4, 27). Also, the nodes separating the three FIV-Ple groups did not exhibit the depth of clade divergence observed in the nucleic acid trees. This observation held true for the domestic cat and puma lentiviruses as well. Consistent with the nucleotide sequence analysis, these amino acid trees of the RT domain also reveal unusually large genetic diversity among African lions and monophyly with respect to host species.

FIG. 8. Neighbor-joining (45) phenetic and PAUP (50) maximum parsimony trees of the RT amino acid sequences from representative FIV-Ples and other feline lentiviruses. Sequences were aligned by the PILEUP program (11) which used the algorithm of Needleman and Wunsch (28). Gaps are given a weight of one residue difference (37). (a) Neighbor-joining tree using distance matrix of amino acid sequences from FIV-Ples from all geographic locales. Branch lengths indicate percent amino acid divergence between the translates. Negative branch lengths were allowed. Bootstrap values (of 100 iterations) are indicated in parentheses in support of each node. (b) PAUP maximum parsimony tree based on a strict bootstrap consensus and on a midpoint root with the branch-swapping and steepest descent options in effect. The tree shown has an overall length of 194 changes and a consistency index of 0.84, indicating a 16% convergence level. The scale and branch lengths are presented as the number of amino acid substitutions (preceding the shell), along with the number of unambiguous sites (synapomorphies) (following the shell). The number of unambiguous sites is equal to branch length minus homoplasy. Bootstrap values (of 100 iterations) are given in parentheses for the respective nodes. See legend to Fig. 3 for abbreviations and for a description of the methods used.

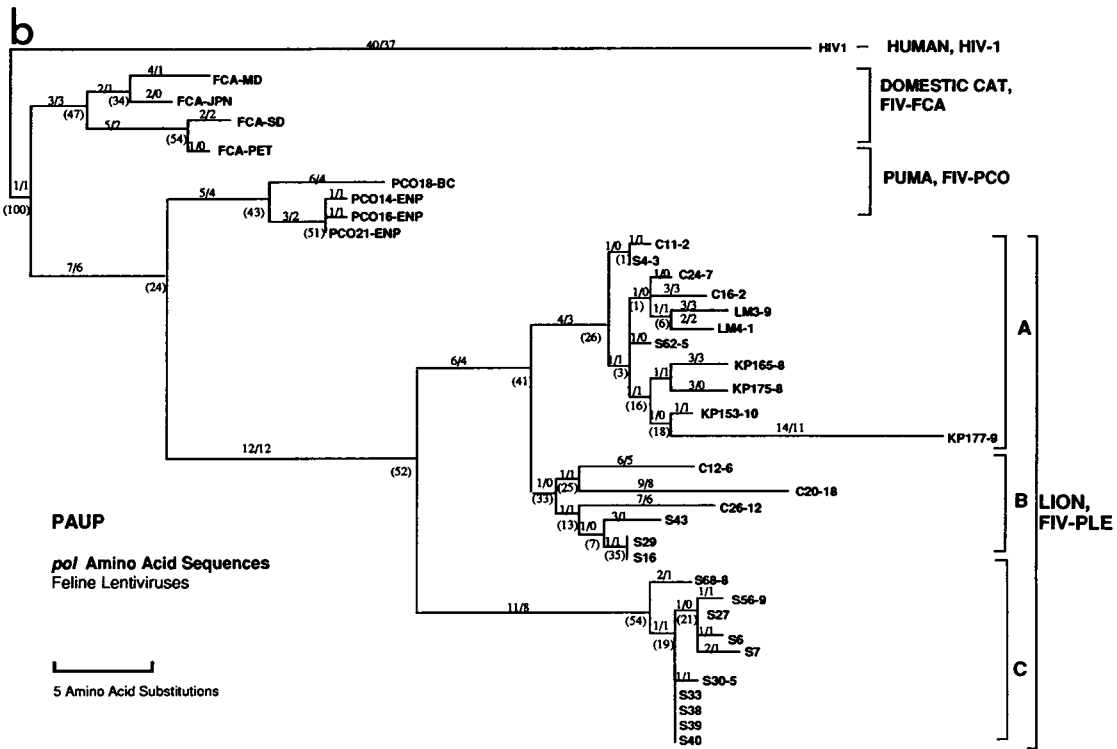
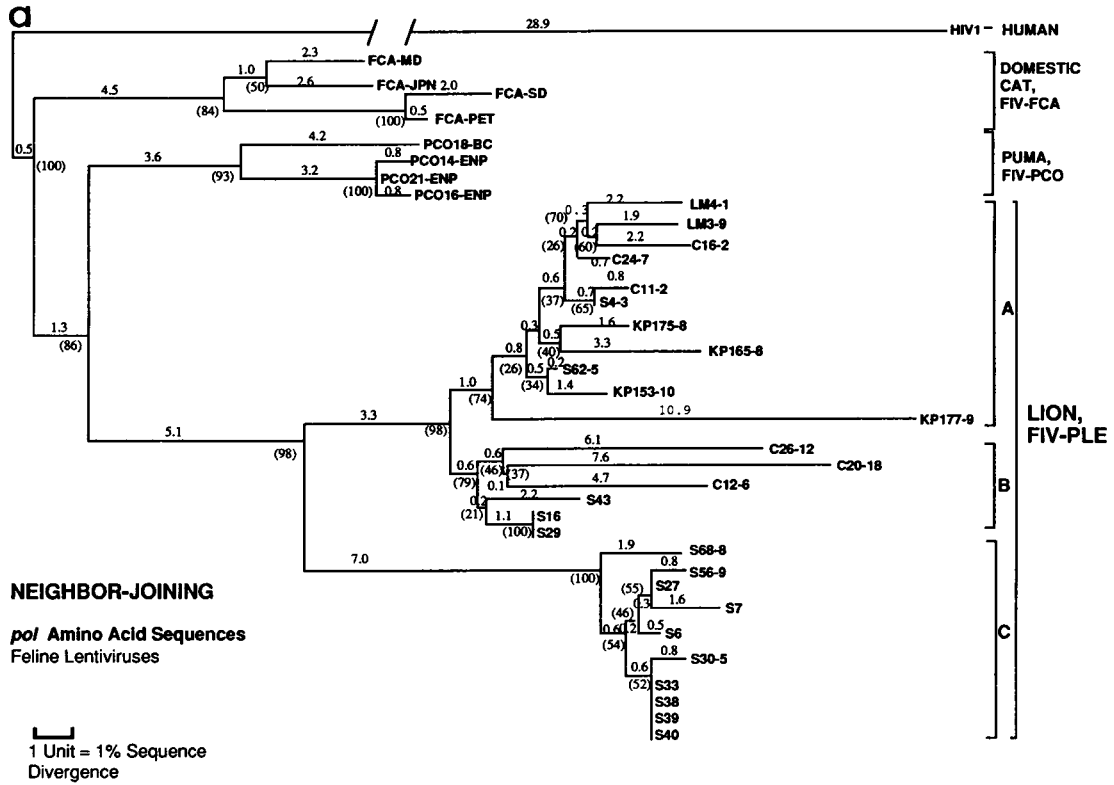

DISCUSSION

This study demonstrates the seroprevalence and phylogenetic divergences of FIV-related lentiviruses in several free-ranging populations of lions. The seroprevalence of FIV in lions exceeds the incidence of cross-reactive antibodies to FIV in all other species of cat (7, 8, 37) and to SIV in free-ranging primates (2, 24, 35). Interestingly, an intercontinental difference was observed with respect to lentivirus exposure. The absence of seroprevalence in Asian lions is reminiscent of the absence of SIV antibodies in free-ranging Asian primates (10, 19). In Africa, lions in Namibia, West Africa, appear free of infection, while East African lions are infected at significant levels. This finding can be interpreted in two ways. FIV-Ple infection may not have emerged in lions until subsequent geographic partitioning of the species or, alternatively, FIV-Ple infection may have been present since the radiation of the lion species but may have failed to persist due to a founder effect of seronegative ancestors of West African lions.

We have presented evidence documenting two cases of seroconversion in male Serengeti lions. These data are reminiscent of the horizontal transmission of infection with FIV in domestic cats through biting (54, 55). Frequent horizontal transmissions of this nature, combined with the highly social and aggressive nature of lions (38, 40), may help to account for the high rates of exposure in the lion populations. The epidemiological data regarding the FIV status of cubs revealed no significant trends supporting the transfer of FIV-Ple infection from mothers to cubs. A large percentage (77%) of positive cubs was born to seronegative dams, while 18% of the cubs born to infected dams remained free of antibodies at the time of sampling. Although we cannot exclude the possibility that some dams may have seroconverted following giving birth but before our sampling dates, these data suggest that maternal transmission (in utero or via milk) is not the sole mechanism of transfer for the virus and probably is not the major route of transmission to other lions.

The phylogenetic analysis of multiple sequences from the same lion has revealed patterns of variation that are consistent with the formation of viral quasispecies *in vivo* (13, 20). Various levels of sequence divergence within infected lions have been observed, with ranges of from less than 1% to more than 4% at the nucleotide level. Fluctuations in the amount of diversity within an infected lion may reflect the length of time an animal has been infected with the virus. In all cases in which multiple clones were derived from a single animal, the sequences were monophyletic with respect to the individual host. These findings suggest a single point of infection followed by the generation of genetic variants *in situ* (13, 20, 22, 31).

The phylogenetic analysis of the FIV-Ple *pol* gene revealed the occurrence of three distinct clades with large sequence divergence levels compared with clades of previously described feline lentiviruses (37, 44). The genetic distance between FIV-Ple clade sequences exceeds that between homologous *pol* sequences found in comparisons of other cat species and is on the order of the distances between lentiviruses from different species of cats. The most primitive clade appears to be clade C, which was found only in the Serengeti, although not all analyses implicated clade C (e.g., Fig. 6c). The deepness of the clade divergences suggests a rather ancient separation of the clades, either in distinct cat species recently introduced into lions or in geographically isolated (allopatric) lion populations that have converged rather recently. The former explanation would gain credence if a lentivirus closely related to one of the clades were discovered in sympatric feline species (e.g., leopards, domestic cats, cheetahs, or African wild cats). Alterna-

tively, the apparent monophyly of the three lion clades within the lion species would support their origin within allopatric lion populations. Whichever the final explanation, the lion lentivirus divergence is likely quite ancient, perhaps extending back to the radiation of the genus *Panthera* into the great cats—lion, leopard, jaguar, etc.—estimated at 1.6 to 2.0 million years ago (47, 52).

It is not yet clear whether the occurrence of FIV-related lentiviruses is associated with immune deficiency or with any pathology in exotic cat species. Although there is compelling evidence for FIV-mediated CD4 T-lymphocyte depletion and associated loss in immune response in domestic cats (1, 9), this has not been observed in wild feline species. However, neither are there sufficient data to conclude that FIV-Ple infection is benign. A thorough analysis of T-cell subsets, immune response, and potential pathology will be required before any firm conclusions can be drawn. If FIV-Ple proves to have little pathology, the situation would be reminiscent of the endemic SIV infection, with no clinical symptoms, in several free-ranging African monkey species. In contrast, Asian macaques manifest an AIDS-like illness when infected with SIV but do not appear to be exposed to SIV in their natural habitat. It seems as if the African species have reached a host-virus accommodation or symbiosis over time, because of either natural selection of genetically resistant host survivors, natural genetic attenuation of viral pathology, or a combination of both. The examples of endemic lentivirus infection in lions and other wild felids provide a rare opportunity to investigate naturally selected solutions to historic outbreaks of debilitating viral infections.

ACKNOWLEDGMENTS

We are very grateful to A. R. Hoelzel, R. Benveniste, and D. Derse for useful discussion; to Stanley Cevario, Walter Knott, and Janice Martenson for excellent technical assistance; to M. Gonda and K. Nagashima for electron microscopy; and to the staff and management of the Frederick Biomedical Supercomputing Center, National Cancer Institute, for allotting required computer time used in the sequence and phylogenetic analyses.

REFERENCES

- Ackley, C. D., J. K. Yamamoto, N. Levy, N. C. Pederson, and M. D. Cooper. 1990. Immunologic abnormalities in pathogen-free cats experimentally infected with feline immunodeficiency virus. *J. Virol.* **64**:5652–5655.
- Allan, J. S., M. Short, M. E. Taylor, S. Su, V. M. Hirsch, P. R. Johnson, G. M. Shaw, and B. H. Hahn. 1991. Species-specific diversity among simian immunodeficiency viruses from African green monkeys. *J. Virol.* **65**:2816–2828.
- Bale, P., P. Simmonds, C. A. Ludlam, J. G. Bishop, and A. J. Leigh-Brown. 1990. Concurrent evolution of human immunodeficiency virus type 1 in patients infected from the same source: rate of sequence change and low frequency of inactivating mutations. *J. Virol.* **64**:6221–6233.
- Barber, A. M., A. Hizi, J. V. Maizel, Jr., and S. H. Hughes. 1990. HIV-1 reverse transcriptase: structural predictions for the polymerase domain. *AIDS Res. Hum. Retroviruses* **6**:1061–1072.
- Barr, M. C., P. P. Calle, M. E. Roelke, and F. W. Scott. 1989. Feline immunodeficiency virus infection in nondomestic felids. *J. Zoo Wildl. Med.* **20**:265–272.
- Benveniste, R. E., L. O. Arthur, C. C. Tsai, R. Sowder, T. D. Copeland, L. E. Henderson, and S. Oroszlan. 1986. Isolation of a lentivirus from a macaque with lymphoma: comparison with HTLV-III/LAV and other lentiviruses. *J. Virol.* **60**:483–490.
- Brown, E. W., S. Miththapala, and S. J. O'Brien. 1993. Prevalence of exposure to feline immunodeficiency virus in exotic felid species. *J. Zoo Wildl. Med.* **24**:357–364.
- Brown, E. W., R. A. Olmsted, J. S. Martenson, and S. J. O'Brien. 1993. Exposure to FIV and FIPV in wild and captive cheetahs.

- Zoo Biol. **12**:135–142.
9. **Brown, W. C., L. Bissey, K. S. Logan, N. C. Pederson, J. H. Elder, and E. W. Collisson.** 1991. Feline immunodeficiency virus infects both CD4⁺ and CD8⁺ T lymphocytes. *J. Virol.* **65**:3359–3364.
 10. **Desrosiers, R. C.** 1990. HIV-1 origins. A finger on the missing link. *Nature (London)* **345**:288–289.
 11. **Devereux, J., P. Haeblerli, and O. Smithies.** 1984. A comprehensive set of sequence analysis programs for the VAX. *Nucleic Acids Res.* **12**:387–395.
 12. **Doolittle, R. F., D. F. Feng, M. S. Johnson, and M. A. McClure.** 1989. Origins and evolutionary relationships of retroviruses. *Q. Rev. Biol.* **64**:1–30.
 13. **Eigen, M.** 1993. Viral quasispecies. *Sci. Am.* **269**:42–49.
 14. **Felsenstein, J.** 1991. PHLYIP: phylogenetic inference package, version 3.0. University of Washington, Seattle.
 15. **Garvey, K. J., M. S. Oberste, J. E. Elser, M. J. Braun, and M. A. Gonda.** 1990. Nucleotide sequence and genome organization of biologically active proviruses of the bovine immunodeficiency-like virus. *Virology* **175**:391–409.
 16. **Gilbert, D. A., C. Packer, A. E. Pusey, J. C. Stephens, and S. J. O'Brien.** 1991. Analytical DNA fingerprinting in lions: parentage, genetic diversity, and kinship. *J. Hered.* **82**:378–386.
 17. **Gojobori, T., E. N. Moriyama, Y. Ina, K. Ikeo, T. Miura, H. Tsujimoto, M. Hayami, and S. Yokoyama.** 1990. Evolutionary origins of the human and simian immunodeficiency viruses. *Proc. Natl. Acad. Sci. USA* **87**:4108–4111.
 18. **Gojobori, T., E. N. Moriyama, and M. Kimura.** 1990. Molecular clock of viral evolution, and the neutral theory. *Proc. Natl. Acad. Sci. USA* **87**:10015–10018.
 19. **Hirsch, V. M., R. A. Olmsted, M. Murphy-Corb, R. H. Purcell, and P. R. Johnson.** 1989. An African primate lentivirus (SIV-sm) closely related to HIV-2. *Nature (London)* **339**:389–392.
 20. **Holmes, E. C., L. Q. Zhang, P. Simmonds, C. A. Ludlam, and A. J. Leigh-Brown.** 1992. Convergent and divergent sequence evolution in the surface envelope glycoprotein of human immunodeficiency virus type 1 within a single infected patient. *Proc. Natl. Acad. Sci. USA* **89**:4835–4840.
 21. **Johnson, P. R., A. Fomsgaard, J. Allan, M. Gravel, W. T. London, R. A. Olmsted, and V. M. Hirsch.** 1990. Simian immunodeficiency viruses from African green monkeys display unusual genetic diversity. *J. Virol.* **64**:1086–1092.
 22. **Johnson, P. R., T. E. Hamon, S. Goldstein, S. Kitov, and V. M. Hirsch.** 1991. The genetic fate of molecularly cloned simian immunodeficiency virus in experimentally infected macaques. *Virology* **185**:217–228.
 23. **Langley, R. J., V. M. Hirsch, S. J. O'Brien, D. Adger-Johnson, R. M. Goeken, and R. A. Olmsted.** Nucleotide sequence and genomic analysis of puma lentivirus (PLV). *Virology*, in press.
 24. **Li, Y., Y. M. Naidu, M. D. Daniel, and R. C. Desrosiers.** 1989. Extensive genetic variability of simian immunodeficiency virus from African green monkeys. *J. Virol.* **63**:1800–1802.
 25. **Lutz, H., E. Isenbugel, R. Lehmann, R. H. Sabaparra, and C. Wolfensberger.** 1992. Retrovirus infections in nondomestic felids: serological studies and attempts to isolate a lentivirus. *Vet. Immunol. Immunopathol.* **35**:215–224.
 26. **Maki, N., T. Miyazawa, A. Hasegawa, M. Hayami, K. Miki, and T. Mikami.** 1992. Molecular characterization and heterogeneity of feline immunodeficiency virus isolates. *Arch. Virol.* **123**:29–45.
 27. **McClure, M. A., M. S. Johnson, D. F. Feng, and R. F. Doolittle.** 1988. Sequence comparisons of retroviral proteins: relative rates of change and general phylogeny. *Proc. Natl. Acad. Sci. USA* **85**:2469–2473.
 28. **Needleman, S. B., and C. D. Wunsch.** 1970. A general method applicable to the search for similarities in the amino acid sequence of two proteins. *J. Mol. Biol.* **48**:443–453.
 29. **O'Brien, S. J., and J. F. Evermann.** 1988. Interactive influence of infectious disease and genetic diversity in natural populations. *Trends Ecol. Evol.* **3**:254–259.
 30. **O'Brien, S. J., P. Joslin, G. L. Smith, R. Wolfe, N. Schaffer, E. Heath, J. Ott-Joslin, P. P. Rawal, K. K. Bhattacharjee, and J. S. Martenson.** 1987. Evidence for African origins of founders of the Asiatic lion species survival plan. *Zoo Biol.* **6**:99–116.
 31. **O'Brien, S. J., and D. L. Mann.** 1992. Adaptive chaos and AIDS. *Curr. Biol.* **2**:203–205.
 32. **O'Brien, S. J., J. S. Martenson, C. Packer, L. Herbst, V. deVos, P. Joslin, J. Ott-Joslin, D. Wildt, and M. Bush.** 1987. Biochemical genetic variation in geographic isolates of African and Asian lions. *Natl. Geogr. Res.* **3**:114–124.
 33. **O'Brien, S. J., M. E. Roelke, L. Marker, A. Newman, C. A. Winkler, D. Meltzer, L. Colly, J. F. Evermann, M. Bush, and D. E. Wildt.** 1985. Genetic basis for species vulnerability in the cheetah. *Science* **227**:1428–1434.
 34. **O'Brien, S. J., D. E. Wildt, and M. Bush.** 1986. The cheetah in genetic peril. *Sci. Am.* **254**:84–92.
 35. **Ohta, Y., T. Masuda, H. Tsujimoto, K. Ishikawa, T. Kodama, S. Morikawa, M. Nakai, S. Honjo, and M. Hayami.** 1988. Isolation of simian immunodeficiency virus from African green monkeys and seroepidemiologic survey of the virus in various non-human primates. *Int. J. Cancer* **41**:115–122.
 36. **Olmsted, R. A., V. M. Hirsch, R. H. Purcell, and P. R. Johnson.** 1989. Nucleotide sequence analysis of feline immunodeficiency virus: genome organization and relationship to other lentiviruses. *Proc. Natl. Acad. Sci. USA* **86**:8088–8092.
 37. **Olmsted, R. A., R. Langley, M. Roelke, R. Goeken, D. A. Johnson, J. Goff, J. Albert, C. Packer, T. Caro, D. E. Wildt, M. Bush, J. S. Martenson, and S. J. O'Brien.** 1992. Worldwide prevalence of lentivirus infection of wild feline species: epidemiologic and phylogenetic aspects. *J. Virol.* **66**:6008–6018.
 38. **Packer, C.** 1986. The ecology of sociality in felids. *In* D. I. Rubenstein and R. W. Wrangham (ed.), *Ecological aspects of social evolution*. Princeton University Press, Princeton, N.J.
 39. **Packer, C., D. A. Gilbert, A. E. Pusey, and S. J. O'Brien.** 1991. Kinship, cooperation and inbreeding in African lions: a molecular genetic analysis. *Nature (London)* **351**:562–565.
 40. **Packer, C., and A. E. Pusey.** 1987. Intrasexual cooperation and the sex ratio in African lions. *Am. Nat.* **130**:636–642.
 41. **Packer, C., A. E. Pusey, H. Rowley, D. A. Gilbert, J. S. Martenson, and S. J. O'Brien.** 1991. Case study of a population bottleneck: lions of the Ngorongoro Crater. *Conserv. Biol.* **5**:219–230.
 42. **Pederson, N. C., E. W. Ho, and J. K. Yamamoto.** 1987. Isolation of a T-lymphotropic virus from domestic cats with an immunodeficiency-like syndrome. *Science* **235**:790–793.
 43. **Phillips, R. E., S. Rowland-Jones, D. F. Nixon, F. M. Gotch, J. P. Edwards, A. O. Agunlesi, J. G. Elvin, J. A. Rothbard, C. R. M. Bangham, C. R. Rizza, et al.** 1991. Human immunodeficiency virus genetic variation that can escape cytotoxic T-cell recognition. *Nature (London)* **354**:453–459.
 44. **Rigby, M. A., E. C. Holmes, M. Pistello, A. Mackay, A. J. Leigh-Brown, and J. C. Neil.** 1993. Evolution of structural proteins of feline immunodeficiency virus: molecular epidemiology and evidence of selection for change. *J. Gen. Virol.* **74**:425–436.
 45. **Saitou, N., and M. Nei.** 1987. The neighbor-joining method: a new method for reconstructing evolutionary trees. *Mol. Biol. Evol.* **4**:406–425.
 46. **Salminen, M., A. Nykaren, H. B. Korrenkontio, M. L. Kantanen, K. Litsola, and P. Leinikki.** 1993. Molecular epidemiology of HIV-1 based on phylogenetic analysis of *in vivo* gag p7/p9 direct sequences. *Virology* **195**:185–194.
 47. **Seidensticker, J., and S. Lumpkin.** 1991. Great cats: majestic creatures of the wild. Weldon Owen Pty. Ltd., Sydney, Australia.
 48. **Smith, T. F., A. Srinivason, G. Schochetman, M. Marcus, and G. Myers.** 1988. The phylogenetic history of lentiviruses. *Nature (London)* **333**:573–575.
 49. **Sonigo, P., M. Alizon, K. Staskus, D. Klatzman, S. Cole, O. Danos, E. Rotzel, P. Tiollais, A. Haase, and S. Wain-Hobson.** 1985. Nucleotide sequence of the visna lentivirus: relationship to the AIDS virus. *Cell* **42**:369–382.
 50. **Swofford, D. L.** 1985. *Phylogenetic analysis using parsimony (PAUP)*, version 3.0. Illinois Natural History Survey, Champaign.
 51. **Swofford, D. L., and G. J. Olsen.** 1990. Phylogeny reconstruction, p. 411–415. *In* D. Hillis and C. Moritz (ed.), *Molecular systematics*. Sinauer Assoc. Inc., Sunderland, Mass.
 52. **Wayne, R. K., R. E. Benveniste, D. N. Janczewski, and S. J. O'Brien.** 1989. Molecular and biochemical evolution of the Carnivora, p. 465–494. *In* J. L. Gittleman (ed.), *Carnivore behaviour, ecology, and evolution*. Cornell University Press, Ithaca, N.Y.

53. Wildt, D. E., M. Bush, K. L. Goodrowe, C. Packer, A. E. Pusey, J. L. Brown, P. Joslin, and S. J. O'Brien. 1987. Reproductive and genetic consequences of founding isolated lion populations. *Nature* (London) **329**:328-331.
54. Yamamoto, J. K., H. Hansen, E. W. Ho, T. Y. Moroshita, T. Okuda, T. R. Sawa, R. M. Nakamura, and N. C. Pederson. 1989. Epidemiologic and clinical aspects of feline immunodeficiency virus infection in cats from the continental United States and Canada and possible mode of transmission. *J. Am. Vet. Med. Assoc.* **194**:213-220.
55. Yamamoto, J. K., E. Sparger, E. W. Ho, P. R. Anderson, T. R. O'Connor, C. P. Mandell, L. Lowenstine, R. Munn, and N. C. Pederson. 1988. Pathogenesis of experimentally induced feline immunodeficiency virus infection in cats. *Am. J. Vet. Res.* **8**:1246-1258.