



A LOW COST PORTABLE TEMPERATURE-MOISTURE SENSING UNIT WITH ARTIFICIAL NEURAL NETWORK BASED SIGNAL CONDITIONING FOR SMART IRRIGATION APPLICATIONS

Aman Tyagi¹, Arrabothu Apoorv Reddy², Jasmeet Singh³, Shubhajit Roy Chowdhury⁴
^{1,2,3,4}Centre for VLSI Design and Embedded System Technology,

IIIT Hyderabad, India.

Emails: ¹aman.tyagiug08@students.iiit.ac.in, ²apoorv.reddyug08@students.iiit.ac.in,
³jasmeet.singhug08@students.iiit.ac.in, ⁴src.vlsi@iiit.ac.in

Submitted: November 12, 2010

Accepted: February 1, 2011

Published: March 1, 2011

Abstract- The recent trends in developing low cost techniques to support cost effective agriculture in developing countries with large population has motivated the development of low cost sensing systems to provide for low cost irrigation facilities and also to provide for conservation of water at the same time. The current paper highlights the development of temperature and soil moisture sensor that can be placed on suitable locations on field for monitoring of temperature and moisture of soil, the two parameters to which the crops are susceptible. The sensing system is based on a feedback control mechanism with a centralized control unit which regulates the flow of water on to the field in the real time based on the instantaneous temperature and moisture values. Depending on the varied requirement of different crops, a lookup table has been prepared and referred to for ascertaining the amount of water needed by that crop. The system based on a microcontroller has been applied on rice and maize fields spanning over area of 1 acres each for 3 weeks and more than 94% of the

plants were found to be alive after experimentation. The cost of the system has been estimated to be as low as 120 INR and is therefore easily deployable in developing countries.

Index Terms: Moisture Sensing, ANN, temperature drift compensation, linearization

I. INTRODUCTION

Irrigation is one of the fundamental problems of agriculture in developing countries. Typically in these developing countries uneducated farmers tend to use more water than required by manual techniques hence wasting them. Soil moisture sensors are typically needed in such situations to indicate to the farmer when it is needed to irrigate the field and when not needed.

A survey of literature reveals some work being carried out in the field of soil moisture sensors. The earliest work in the field of soil moisture has been reported by Gaskin et al in [1]. They used a frequency domain sensor to monitor the change in the soil impedance due to variation of water content. Currently frequency domain sensors are commercialized as single and multi sensor capacitor probes with different installation and monitoring techniques [2]. Frequency Domain sensors are much better for humid tropical soil with much easier calibration procedure [4]. Recent development in moisture sensing of soil are with fiber optic sensor [5, 6], dye doped plastic fibers [8], ceramic sensor [10] are either too expensive or has reliability issues. Method of measuring soil moisture by neutron scattering [11] cannot be applied practically. Temperature sensors that are

currently being used are linear with temperature, 0.05 mV/°C scale factor, with 0.5°C accuracy guarantee able (at +25°C). Low cost is assured by trimming and calibration at the wafer level [12, 14].

The current work aims to develop a microcontroller based low cost soil temperature and moisture monitoring system that can track the soil temperature and moisture at different locations of the field in real time and thereby allow water to be sprinkled on to the field if the soil temperature goes above and/or the soil moisture falls below a prescribed limit depending in the nature of crop grown in the soil. The sensors take the inputs like moisture, temperature and provide these inputs to the microcontroller. The microcontroller converts these inputs into its desired form with the program that is running on it and gives outputs in the mode of regulation of water flow according to the present input conditions. The software or a small operating System that's running on the Microcontroller, provides a very simple to use user interface. It uses a valvular control as output and 4 buttons as input device, to provide the name of the crop being grown as input.

The paper is organized as follows: The paper is organized as follows. Section 2 focuses on the temperature and moisture sensors. The developed moisture sensor suffer from temperature drift and non linearity effects and these non idealities have been minimized with the aid of ANN based temperature compensation in section 3. Section 4 discusses the development of the smart processing unit on a microcontroller based system. Section 5 presents the results and discussions.

II. TEMPERATURE AND MOISTURE SENSORS

- A. *Temperature Sensors:* The current work uses temperature sensors for monitoring the soil temperature. For temperature measurement, LM-35DZ sensor has been used. It has an output voltage that is proportional to the temperature being measured. The scale factor is $0.01 \text{ V}/^\circ\text{C}$. The LM-35DZ does not require any external calibration or trimming and maintains an accuracy of 0.4°C at room temperature and $\pm 0.8^\circ\text{C}$ over a range of 0°C to $+100^\circ\text{C}$. Another important characteristic of the LM-35DZ is that it draws only $60 \mu\text{A}$ of current from its supply and possesses a low self-heating capability, the sensor self-heating causes less than 0.1°C temperature rise in still air.
- B. *Moisture Sensors:* The present work comprises of development of a soil moisture sensor. The soil moisture sensor has been developed using the basic property that the resistance of the soil between two points decreases with the increase of water content in it. We know that water is a good conductor of electricity in the presence of ions. So, greater the amount of with electrolytes in the soil, greater will be the conductivity of the soil. This means that the resistance of the soil decreases. However, it has to be ensured that chemical fertilizers are not administered into the soil within a radius of 1m from the sensor. This will ensure that the conductivity of the soil will not change at the point of measurement due to application of chemical fertilizers. The developed sensor has two probes that are inserted into the soil. The distance between the probes is kept fixed. A resistance is connected in series with the probe and current is passed through it. The set-up works like a voltage divider and the voltage of the mid-point is

given to the ADC of the microcontroller. The basic construction of probes and the circuit is given below:

1) *Probes*: The Probes are made using two metal rods tied together using an insulating tape. The two probes are separated by a small rubber block which keeps the two probes apart [15]. The photograph of the probe is shown below in figure 1:



Figure 1. Photograph of the soil moisture sensor

2) *Circuit*: The circuit consists of an oscillator that gives a Sine wave with frequency of 1 KHz. This Sine wave is given to the one end of the probe. At the other end of the probe there is a series resistance and the output between these 2 is given to a half wave rectifier followed by a low pass filter. This setup gives the DC value depending on the resistance due to soil between the probes. The circuit diagram is shown below in figure 2:

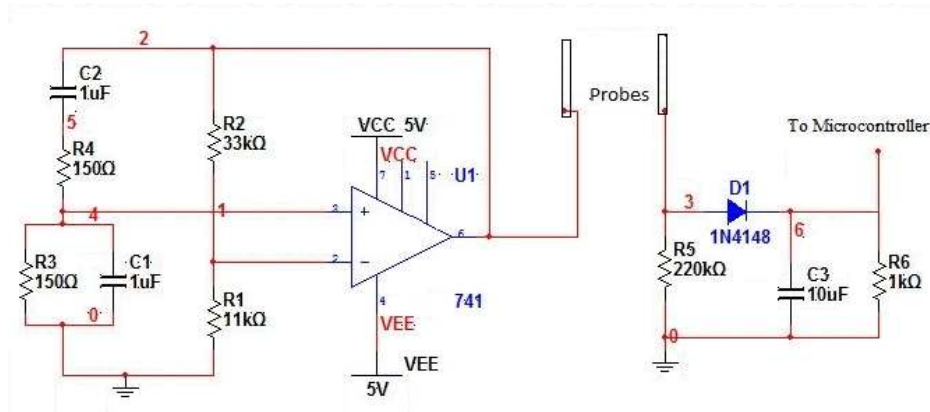

Figure 2. Moisture Sensor Circuit

III. ANN BASED TEMPERATURE DRIFT AND NON LINEARITY COMPENSATION OF SENSOR USING CONVENTIONAL NEURON MODEL

The Soil Moisture sensor designed does not give a voltage output linear to the relative moisture as can be seen from Fig. 3. Moreover, the moisture sensor suffers a temperature drift. In order to compensate for this non-linearity and temperature drift, the inverse modeling of the sensor has been done using an ANN to linearize the voltage output irrespective of the ambient temperature. Fig.3. shows the output voltage values proportional to moisture content of soil of the sensor at different temperatures.

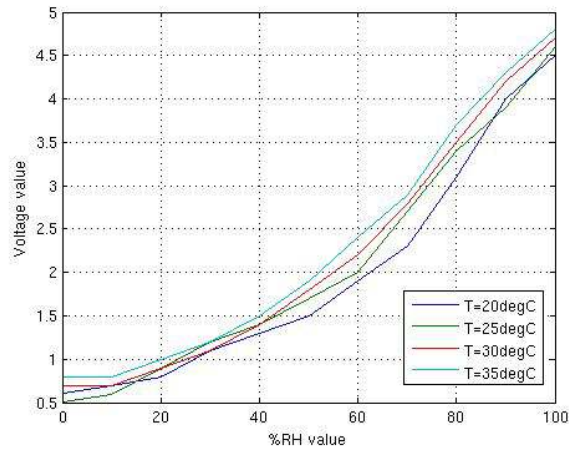

Fig.3. % Moisture content at Different Temperatures

For linearization of the sensor output characteristics as also temperature drift compensation, a multi layered perceptron based neural network has been used. The ANN consists of one input, one hidden layer and one output layer. The input layer consists of 2 nodes (for temperature and %moisture inputs), while the hidden layer consists of 4 neurons. The architecture of the neural network is shown in figure 4.

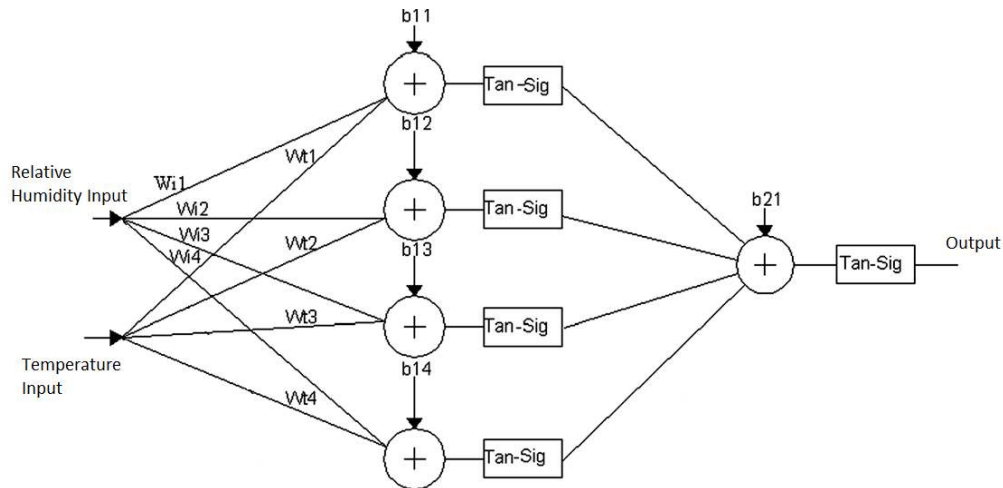

Figure 4. Artificial Neural Network Model for temperature drift and non linearity compensation of soil moisture sensor

The selection of neuron is done on the basis of minimum MSE, weight factor and bias values suitable for hardware implementation and its dynamic range [17]. Moreover, the number of neurons has been kept as small as possible for simplicity in circuit implementation at the subsequent stage.

The mathematical model of the neuron is given by the equation:

$$\tau \frac{d u}{d t} = f\left(\sum_j w_{ij} x_j + u_i\right),$$

where w_{ij} is the synaptic weight between i^{th} and j^{th} neurons, u_i

is the internal state of i^{th} neuron, x_j is the output of the j^{th} neuron, τ is the time constant of the neuron output, f refers to the tan-sigmoid activation function of the neuron. The chosen training method is back propagation algorithm and the simulation studies are carried out in MATLAB [18]. Table 1 shows the values of the synaptic weights and biases obtained while training the model.

Table 1. Synaptic weights and biases of the ANN

iw(1,1){input to hidden layer weights	iw(2,1){hidden to output layer weights	b(1){bias to hidden layer neurons }	b(2){bias to output layer neuron }
-0.7458; 0.097066	15.3497	-13.388	-13.5047
-0.26681; 0.0031053	-47.2423	-1.3565	
7.8241; -2.4914	0.099211	39.9804	
1.0265; 0.030163	-13.0118	9.5881	

The linearized output of the ANN is shown in the following figure 5.

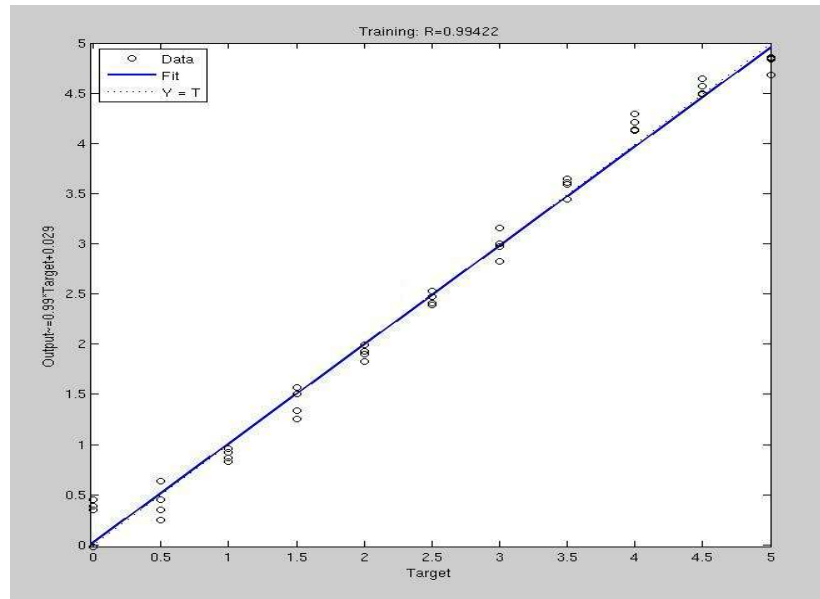

Figure 5. Linearized output after using the neural network

The % error in linearization has been found to be less than 1%, which implies the high degree of accuracy obtained with the ANN based linearization.

IV. DEVELOPMENT OF THE SMART DATA PROCESSING UNIT

The data processing unit is centred on an Atmel AtMega 16 microcontroller [19]. The PCB for the microcontroller has been developed by us. The layout of the PCB and its actual image are shown below in figure 6 and figure 7 respectively:

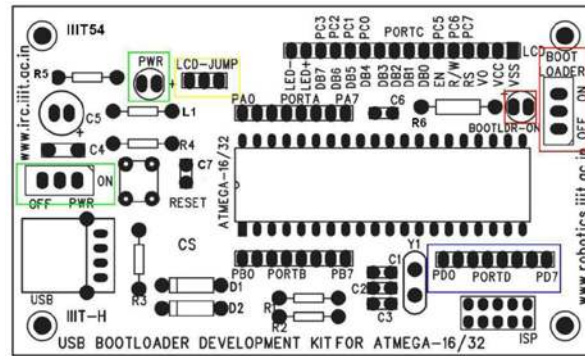

Figure 6. PCB Layout of the signal processing circuit



Figure 7. Picture of the signal processing circuit

Figure 8 shows the overall system architecture:

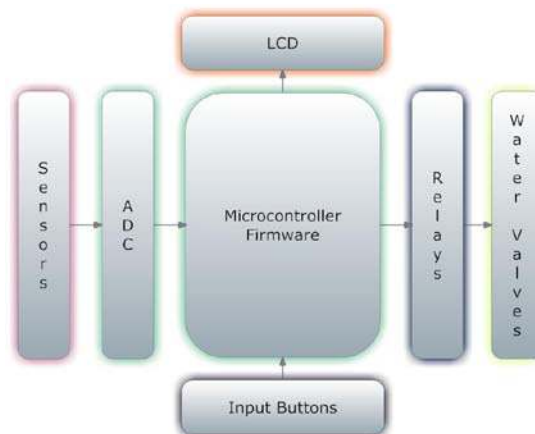

Figure 8. Overall System Architecture

The pin connections and their data direction that are used for connecting various sensors, input buttons, LCD and output to water valves is given in Fig.9: The whole circuit operates on a 5V power supply.

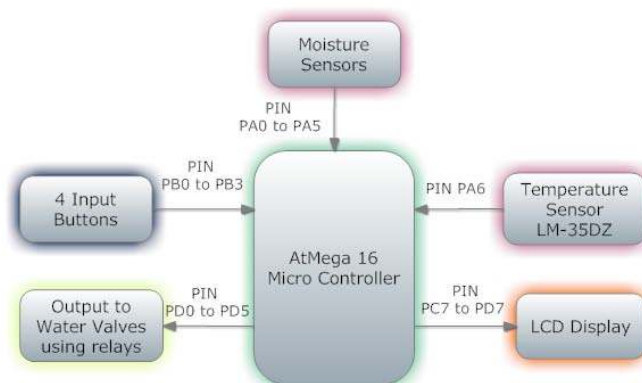

Figure 9.Circuit connections of the microcontroller

The microcontroller has a program running on it, which acts as a small Operating System. It has a user interface, and takes inputs from the user and accordingly takes actions. The temperature sensor output is directly applied to the ADC of the microcontroller and stored in the internal register. The microcontroller takes the analog sensor output of the moisture sensor and converts them into a digital value ranging from 0 to 1023 using its Analog to Digital Converter (ADC). These ADC values are linearized using the ANN based inverse model. For different crops, the humidity and temperature requirements for optimum growth are different. In our current research, we have performed experiments with rice, wheat, maize, sorghum, sugarcane and groundnut. Table 2 shows the soil moisture requirements for different crops. If the soil temperature rises above the threshold value and the moisture content falls below the threshold, the water supply is turned on by issuing a control signal from the microcontroller. This is achieved by

turning on a relay, which in turn opens a water valve, and water is given to only to that area of the field.

Table 2: Water requirements and corresponding soil moisture requirements 6 crops.

Crop	Water Requirement (mm)*	Soil Moisture (% V/V)**
Rice	900 – 2500	31.03 – 55.55
Wheat	450 – 650	18.36 – 24.52
Maize	500 – 800	20.00 – 28.57
Sorghum	450 – 650	18.36 – 24.52
Sugarcane	1500 – 2500	42.85 – 55.55
Groundnut	500 – 700	20.00 – 25.92

*Water Requirement in mm has been referenced from an online resource [20].

**Volumetric water content and soil moisture are given by the following formulae respectively. For calculations, Soil Depth is taken as 2 meters.

$$\text{Volumetric Water Content} = (\text{Volume of Water}) / (\text{Volume of Soil} + \text{Volume of Water})$$

$$\text{Soil Moisture \%} = (\text{Volumetric Water Content}) * 100$$

The overall software architecture is given in Fig.10. The software architecture is so designed to make usage simple and easy to understand and debug. The arrows in the figure indicate the dependence between the different modules.

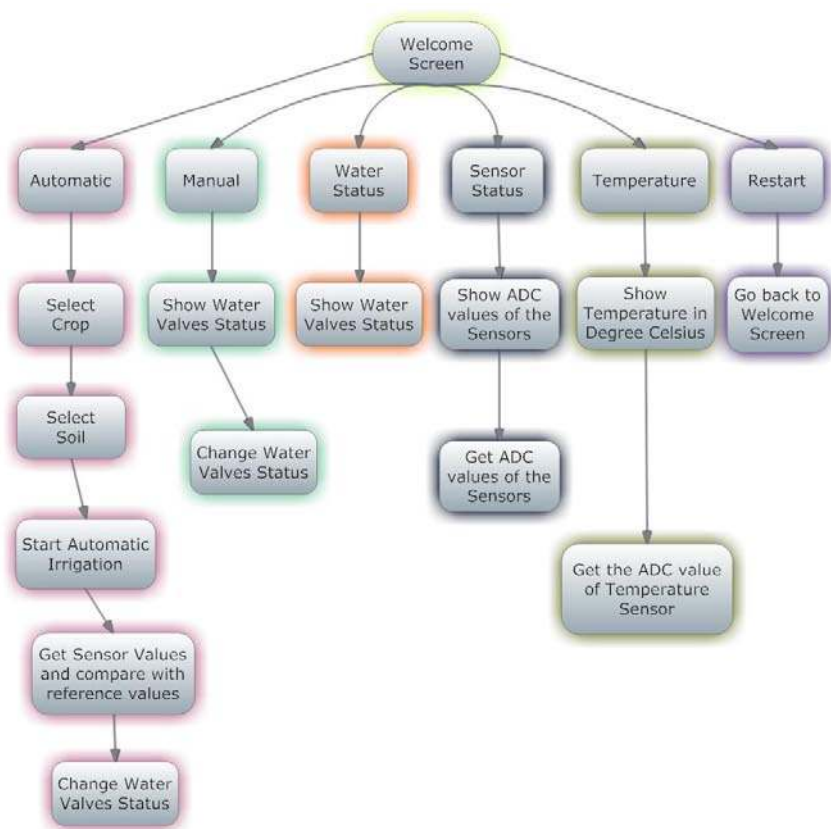

Figure 10. Overall Software Architecture

V. RESULTS AND DISCUSSION

The moisture sensors being developed give an analog value ranging from 0 to 5V for different moisture levels. Figure 3 shows the output performance of the soil moisture sensor. As evident from the figure the increase is non-linear in the region of 30 to 100. An ANN based model has been used to compensate this non-linearity. The linearized output is shown in Figure 6.

Experiments were carried out over rice and maize fields spanning over an area of 1 acres of land each for 3 weeks. The sensing units were placed at distances of 10 meters. They

were all networked with the smart signal conditioning unit that samples the sensor outputs in a round robin fashion. The number of plants that remained alive as a result of the irrigation approach was monitored. A graph has been plotted showing the percentage of plants alive after a certain number of days. Figure 11 shows the graph percentage of plants alive versus number of days:

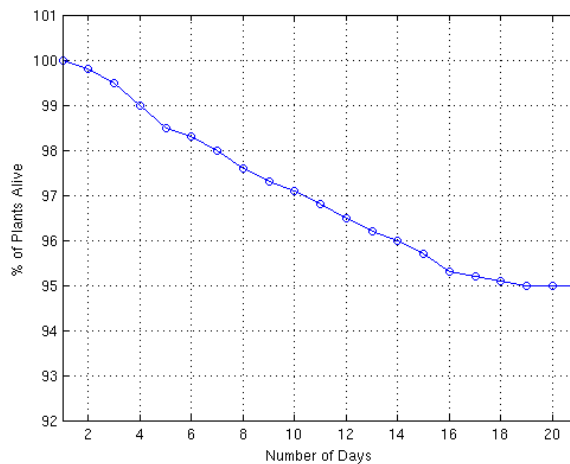

(a)

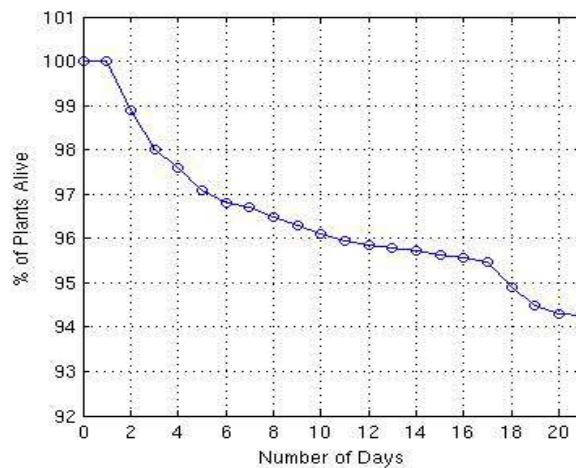

(b)

Figure. 11 Graph showing percentage of plants alive over time (a) Rice (b) Maize

From figure 11 it is evident that even after 21 days more than 94% of plants on average were alive and were found to grow normally using the proposed irrigation approach. Moreover, it is also clear from the curve that the curve almost settles to a constant value after 16 days which implies almost no more plants die after 18 days. The system is very useful for agriculture applications particularly in semi arid areas that are sparsely populated, so that human involvement and intervention is not needed for irrigation purposes.

VI. CONCLUSION

The current work aims to develop a smart irrigation system using soil temperature and moisture sensor. The proposed system enables irrigation of the field only when it is needed and thus serves to conserve water. Also, the proposed system eliminates the intervention of human being for irrigation purposes. The reliability of the sensing system is justified by the percentage of plants that survived even after 3 weeks. The system based on a microcontroller has been applied on a rice and maize fields spanning over an area of 1 acres for 3 weeks and more than 94% of the plants were found to be alive after experimentation. The system is particularly useful for agriculture applications in sparsely populated semi arid areas since human involvement and intervention is not needed for irrigation purposes. Further works are going on to increase the efficiency of the moisture sensors so as to minimize the effects of fertilizers on the value of soil moisture.

VII. ACKNOWLEDGEMENTS

The authors would like to acknowledge the support lent by Centre for VLSI and Embedded Systems and the Robotics Research Lab for providing the necessary fund and guidance to carry out the work.

REFERENCES

- [1] G.J. Gaskin, J.D. Miller, 'Measurement of soil water content using a simplified impedance measuring technique', Journal of Agricultural Engineering Research 63, 153-160, 1996.
- [2] A. Fares, H. Hamdhani, D.M. Jenkias, 'Temperature- Dependent sealed frequency: Improved accuracy of multisensory capacitance probes', Soil Science Society of America Journal, Vol-71, pp. 894 - 900, 2007.
- [3] P.Bhattacharyya, D. Verma, D. Banerjee, 'Microcontroller Based Power Efficient Signal Conditioning Unit for Detection of a Single Gas Using MEMS Based Sensor', International journal on smart sensing and intelligent systems, Vol. 3, No. 4; pp. 771-782, December 2010,.
- [4] Edzo Veldkamp and Joseph J. O'Brien, 'Calibration of a Frequency Domain Reflectometry Sensor for Humid Tropical Soils of Volcanic Origin', Soil Science Society of America Journal, Vol-64 No. 5, pp. 1549-1553, 2000.
- [5] Wesley Kunzler, Sean G. Calvert, and Marty Laylor, "Measuring Humidity and

- Moisture with Fiber Optic Sensors," Proceedings of SPIE, Vol. 5278, p. 86, 2003.
- [6] Sunil K. Khijwania, Kirthi L. Srinivasanb and Jagdish P. Singha, 'An evanescent-wave optical fiber relative humidity sensor with enhanced sensitivity', Volume 104, Issue 2, pp 217-222, Jan 2005.
- [7] Debangshu Dey, Sugata Munshi, 'Simulation Studies on A New Intelligent Scheme for Relative Humidity and Temperature Measurement Using Thermistors in 555 Timer Circuits', International journal on smart sensing and intelligent systems, Vol. 3 No. 2; pp.217-229, June 2010,.
- [8] Shinzo Muto, Akihiko Fukasawa, Takayuki Ogawa, Masayuki Morisawa and Hiroshi Ito, 'Optical Detection of Moisture in Air and in Soil Using Dye-Doped Plastic Fibers', Japanese Journal of Applied Physics, 29 (1990) pp. L1023-L1025.
- [9] M. Hernaez, C. R. Zamarreno, I. Del Villar, F. J. Arregui, I.R. Matias, 'Optical Fiber Humidity Sensor Based on Lossy Mode Resonances', International journal on smart sensing and intelligent systems, Vol. 2 No. 4; pp.653-660, December 2009.
- [10] T. Seiyama, N. Yamazoe, H. Arai, 'Ceramic Humidity Sensors', IEEE Transactions on Components Hybrids, and Manufacturing Technology', Jun 1980, Volume: 3 Issue:2, pp. 85-96.
- [11] I.F. Long, B. K. French, 'Measurement of soil moisture in the field by neutron moderation', Science, Vol. 18, pp.149-166, 1967.
- [12] 'LM-35 Precision centigrade temperature sensors', Datasheet No. DS005516, National Semiconductor Corporation, 2000.

- [13] Anton Fuchs, Michael J. Moser, Hubert Zangl, Thomas Bretterklieber, 'Using Capacitive Sensing to Determine the Moisture Content of Wood Pellets – investigations and Application', International journal on smart sensing and intelligent systems Vol. 2 No. 4; pp.293-308 June 2009,.
- [14] Jacob Fraden, 'Handbook of Modern Sensors: Physics, Designs, and Applications', Volume 382, Number 1, pp 8-9, Springer Verlag, Fourth Edition, 2010.
- [15] Ronald M. Benrey, 'This sprinkler-control system thinks for itself', Popular Science, April 1968, P - 182.
- [16] Dilip Kumar Ghara, Debdulal Saha, Kamalendu Sengupta, 'Implementation of linear trace moisture sensor by nano porous thin film moisture sensor and NLamp', International journal on smart sensing and intelligent systems, Vol. 1 No. 4; pp.955-969, December 2008,.
- [17] N.P. Futane , S. Roy Chowdhury , C. Roy Chowdhury , H. Saha, 'ANN based CMOS ASIC design for improved temperature-drift compensation of piezoresistive micro-machined high resolution pressure sensor', Microelectronics Reliability 50(2010) 282-291.
- [18] S.D. Stearns and R.A. David, 'Signal Processing Algorithms in MATLAB. Prentice Hall, 1st edition', 1996.
- [19] 'AtMega16', Datasheet No. 2466HS–AVR–07/10, ATMEL Corporation.
- [20] Website of Ikisan Limited, www.ikisan.com (Last visited on January 13,2010).