

## A master-slave robot for vitreo-retinal eye surgery

***Citation for published version (APA):***

Meenink, H. C. M., Hendrix, R., Rosielle, P. C. J. N., Steinbuch, M., Nijmeijer, H., & Smet, de, M. D. (2010). A master-slave robot for vitreo-retinal eye surgery. In H. Spaan, P. Shore, H. Brussel, van, & T. Burke (Eds.), *Proceedings of the 10th International Conference of European Society for Precision Engineering and Nanotechnology, 31 May-4 June 2010, Delft Netherlands* (pp. 408-411). European Society for Precision Engineering and Nanotechnology.

***Document status and date:***

Published: 01/01/2010

***Document Version:***

Publisher's PDF, also known as Version of Record (includes final page, issue and volume numbers)

***Please check the document version of this publication:***

- A submitted manuscript is the version of the article upon submission and before peer-review. There can be important differences between the submitted version and the official published version of record. People interested in the research are advised to contact the author for the final version of the publication, or visit the DOI to the publisher's website.
- The final author version and the galley proof are versions of the publication after peer review.
- The final published version features the final layout of the paper including the volume, issue and page numbers.

[Link to publication](#)

***General rights***

Copyright and moral rights for the publications made accessible in the public portal are retained by the authors and/or other copyright owners and it is a condition of accessing publications that users recognise and abide by the legal requirements associated with these rights.

- Users may download and print one copy of any publication from the public portal for the purpose of private study or research.
- You may not further distribute the material or use it for any profit-making activity or commercial gain
- You may freely distribute the URL identifying the publication in the public portal.

If the publication is distributed under the terms of Article 25fa of the Dutch Copyright Act, indicated by the "Taverne" license above, please follow below link for the End User Agreement:

[www.tue.nl/taverne](http://www.tue.nl/taverne)

***Take down policy***

If you believe that this document breaches copyright please contact us at:

[openaccess@tue.nl](mailto:openaccess@tue.nl)

providing details and we will investigate your claim.

# A master-slave robot for vitreo-retinal eye surgery

Thijs Meenink  
 Department of Mechanical Engineering  
 Control Systems Technology  
 PO Box 513, WL 1.59  
 5600 MB Eindhoven  
 The Netherlands  
 Tel. +31 40 247 4580  
 Fax. +31 40 246 1418  
 h.c.m.meenink@tue.nl

## Introduction

Vitreo-retinal eye surgery relates to surgery at the inner side at the back of the eye, e.g. the vitreous humor or the retina. Nowadays it is performed manually via a trocar, not unlike minimally invasive surgery (MIS). Steady hand movements are required to operate ocular tissue with high accuracy. During eye surgery forces are below the detection limit (60 mN). Robotically assisted surgery with force feedback can extend existing surgical skills, using a master-slave system (fig. 1).

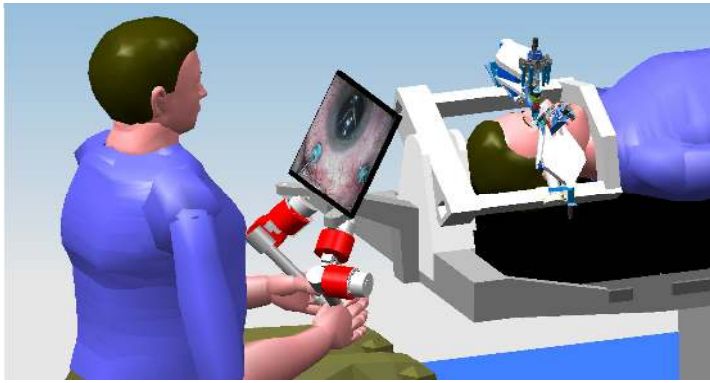

Figure 1. Concept design of the master-slave system.

The slave robot, performing the actual surgery, is controlled by the surgeon via a master. Key properties of the master-slave system are: (1) easy to place, (2) compact and light weight design, (3) direct view on the patient, (4) intuitive operation, (5) suitable for a complete intervention and (6) an ergonomic operating posture.

## Master device

Both master and slave parts are supported by a frame, which is mounted to the surgical table. The main components of the master are haptic interfaces and a 3D-display. An intuitive working environment is created by virtually placing the hands of the surgeon on the instrument inside the eye, therefore the geometry of the degrees of freedom (DoFs) are placed as such (fig.2).

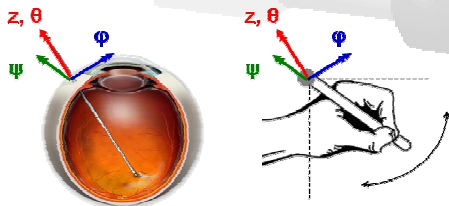

Figure 2. The 4 DoFs of the instrument and the haptic interface

All DoFs in the master are equipped with a force feedback motor and are backdrivable. Position is measured by encoders.

## Slave

The slave is provided with multiple instrument manipulators (IMs, fig. 3) and is adjustable to position the IMs over either the left or right eye. The design of the IM is such that the point where the instrument enters the eye is kinematically defined. This results in an intrinsically safe design. Four DoFs about the entry point are desired (fig. 2, left). The range of motion is indicated below.

$\phi$ - $\psi$	Z	$\theta$
+/- 45°	>30 mm	360°

A fifth DoF is used to actuate the instrument, e.g. forceps. Key properties of the IM are: (1) force measurement with a resolution of 1 mN, (2) manipulation with an accuracy of <10  $\mu$ m, (3) high stiffness, (4) backlash free and (5) it is equipped to perform a complete intervention.

Different instruments are used during surgery, therefore each IM is equipped with an onboard instrument changing system. It consists of a rack holding instruments and an actuator to select the desired instrument. The manipulator Z-Drive and a bistable instrument clamp are used to effect the change automatically in a fast and secure way.

Currently the first IM is realized (fig. 4) at the TU/e GTD for a test program.

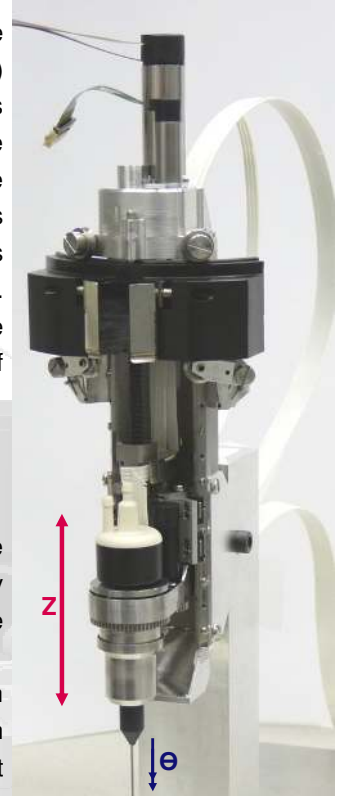

Figure 4. The  $\theta$ -Z Manipulator

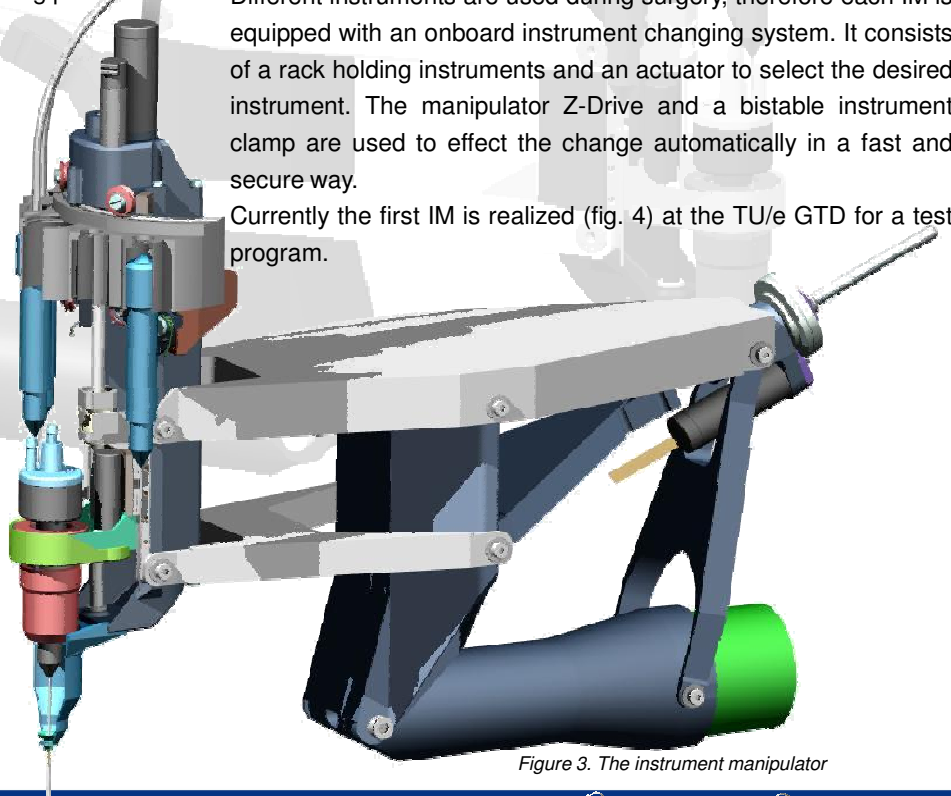

Figure 3. The instrument manipulator

