

## DOCUMENT RESUME

ED 093 723

SE 018 120

AUTHOR Higgins, Jon L., Ed.  
TITLE A Metric Handbook for Teachers.  
INSTITUTION National Council of Teachers of Mathematics, Inc.,  
Washington, D.C.  
PUB DATE 74  
NOTE 132p.  
AVAILABLE FROM The National Council of Teachers of Mathematics, 1906  
Association Drive, Reston, Virginia 22091 (\$2.40)

EDRS PRICE MF-\$0.75 HC Not Available from EDRS. PLUS POSTAGE  
DESCRIPTORS Activity Learning; Curriculum; Elementary School  
Mathematics; \*Instruction; \*Instructional Materials;  
Learning Activities; \*Mathematics Education;  
\*Measurement; \*Metric System; Secondary School  
Mathematics; Teaching Techniques

## ABSTRACT

This handbook has been compiled to provide a reference for teachers at all levels who are implementing the metric system in their classroom. It includes practical suggestions and recommendations for teaching the metric system, as well as papers identifying and discussing the fundamental mathematical and psychological issues underlying the teaching of the metric system in the schools. The articles--some reprinted from recent issues of the "Arithmetic Teacher," some written especially for this publication--are organized under five headings: Introducing the Metric System; Teaching the Metric System: Activities; Teaching the Metric System: Guidelines; Looking at the Measurement Process; and Metrication, Measure, and Mathematics. (Editor/DT)

U.S. DEPARTMENT OF HEALTH  
EDUCATION & WELFARE  
NATIONAL INSTITUTE OF  
EDUCATION

THIS DOCUMENT HAS BEEN REPRO-  
DUCED EXACTLY AS RECEIVED FROM  
THE PERSON OR ORGANIZATION ORIGIN-  
ATING IT. POINTS OF VIEW OR OPINIONS  
STATED DO NOT NECESSARILY REPRESENT  
OFFICIAL NATIONAL INSTITUTE OF  
EDUCATION POSITION OR POLICY.

PERMISSION TO REPRODUCE THIS COPY-  
RIGHTED MATERIAL BY MICROFICHE ONLY  
HAS BEEN GRANTED BY

N. C. T. M.

TO ERIC AND ORGANIZATIONS OPERATING  
UNDER AGREEMENTS WITH THE U.S. OFFICE  
OF EDUCATION. FURTHER REPRODUCTION  
OUTSIDE THE ERIC SYSTEM REQUIRES PER-  
MISSION OF THE COPYRIGHT OWNER.

# *A Metric Handbook for Teachers*

*edited by*  
JON L. HIGGINS

A Mathematics Education Resource Series Project  
of the ERIC Information Analysis Center for  
Science, Mathematics, and Environmental Education  
Columbus, Ohio

Published by the  
NATIONAL COUNCIL OF TEACHERS OF MATHEMATICS  
1906 Association Drive, Reston, Virginia 22091

ED 093723

SE 018 120

*Library of Congress Cataloging in Publication Data:*

Higgins, Jon L            comp.  
    A metric handbook for teachers.

"A mathematics education resource series project of the ERIC Information Analysis Center for Science, Mathematics, and Environmental Education, Columbus, Ohio."

Includes bibliographies.

1. Metric system--Study and teaching--United States.  
I. ERIC Information Analysis Center for Science, Mathematics, and Environmental Education. II. Title.  
QC93.H53                    389'.152                    74-13468

Parts of this handbook have appeared previously in issues of the *Arithmetic Teacher* and are copyrighted by the National Council of Teachers of Mathematics. They must not be reproduced without the permission of the Council. Also, "Historical Steps toward Metrication" and "Metric Curriculum: Scope, Sequence, and Guidelines" are adapted from copyrighted materials published by the Agency for Instructional Television and must not be reproduced without their permission.

"Activities for Introducing Metric Concepts to Teachers," "Metric Equipment: How to Improve," "Think Metric--Live Metric," "Ten Basic Steps for Successful Metric Measurement," and "Metrication, Measure, and Mathematics" were prepared pursuant to a contract with the National Institute of Education, U. S. Department of Health, Education, and Welfare. Contractors undertaking such projects under government sponsorship are encouraged to express freely their judgment in professional and technical matters. Points of view or opinions do not, therefore, necessarily represent official National Institute of Education position or policy.

# Contents

<b>Introduction</b>		1
<b>A Quick Guide to the Handbook</b>		3
<b>1. Introducing the Metric System</b>		
Activities for Introducing Metric Concepts to Teachers	<i>Jon L. Higgins</i>	7
Inching Our Way towards the Metric System	<i>Gerardus Vervoort</i>	12
The Metric System: Past, Present—Future?	<i>Arthur E. Hallerberg</i>	17
Historical Steps toward Metrication	<i>Marilyn N. Svardam</i>	26
<b>2. Teaching the Metric System: Activities</b>		
Experiences for Metric Missionaries	<i>Lottie Viets</i>	31
Metric Equipment: How to Improve	<i>Jon L. Higgins</i>	36
Think Metric—Live Metric	<i>Richard J. Shunway, Larry A. Sachs, and Jon L. Higgins</i>	40
Procedures for Designing Your Own Metric Games for Pupil Involvement	<i>Cecil R. Truchblood and Michael Szabo</i>	45
Ideas	<i>George Immerzeel and Don Wiederanders</i>	50
<b>3. Teaching the Metric System: Guidelines</b>		
Schools Are Going Metric	<i>Fred J. Helgren</i>	69
Metric: Not <i>If</i> , but <i>How</i>	<i>NCTM Metric Implementation Committee</i>	72

Teaching the Metric System as Part of Compulsory Conversion in the United States	<i>Vincent J. Hawkins</i>	76
Metric Curriculum: Scope, Sequence, and Guidelines	<i>Marilyn N. Suydam</i>	81
<b>4. Looking at the Measurement Process</b>		
Ten Basic Steps for Successful Metric Measurement	<i>Jon L. Higgins</i>	89
Thinking about Measurement	<i>Leslie P. Steffe</i>	93
Teaching about "About"	<i>Harold C. Trimble</i>	100
<b>5. Metrication, Measure, and Mathematics</b>		
Metrication, Measure, and Mathematics	<i>Alan R. Osborne</i>	107

# Introduction

Clearinghouses of the Educational Resources Information Center (ERIC) are charged with both information gathering and information dissemination. As the growing movement to convert the basic measuring systems of the United States to the metric system became apparent, the ERIC Clearinghouse for Science, Mathematics, and Environmental Education commissioned a paper that would identify and discuss the fundamental mathematical and psychological issues underlying the teaching of the metric system in the schools. The result of that commission is the article "Metrication, Measure, and Mathematics" in this handbook.

As work on that paper progressed, it became obvious that a compilation of practical suggestions and recommendations for teaching the metric system was also needed. Indeed, it seemed that a theoretical paper discussing basic issues would be enhanced by including it as a component of such a collection. The April 1973 and May 1973 issues of the *Arithmetic Teacher* provided excellent sources of such recommendations, and the ERIC Clearinghouse contacted the National Council of Teachers of Mathematics to explain the concept of the handbook and to seek permission to include NCTM materials. The enthusiastic response of NCTM resulted in the suggestion of a joint project. The scope of the original project was greatly expanded, and additional short papers were commissioned to fill gaps in coverage within the handbook.

Although the papers in this handbook present a remarkably unified set of recommendations, there are some contradictions in specific details, as might be expected when seventeen different authors are represented. The ultimate resolution of these conflicts will depend on what happens in classrooms, since successful classroom learning is the final test of educational theory. For this reason, the handbook is addressed to teachers. It is hoped that it will prove to be both a useful and a frequently used resource for teachers.

# A quick guide to the handbook

This handbook has been compiled to provide a reference for teachers at all levels who are implementing the metric system in their classrooms. Here is a brief summary of the articles in the handbook that may make the task of finding specific information somewhat easier.

## **1. Introducing the Metric System**

Are you interested in arbitrary units, fundamental metric units, and schemes for subdividing units? The article "Activities for Introducing Metric Concepts to Teachers" presents these ideas via sample classroom activities that require inexpensive or homemade equipment.

Do you need to convince someone that the English system of measurement is cumbersome? Then read "Inching Our Way towards the Metric System." This article also presents tables of basic relationships between metric units and an explanation of how the metric system was developed.

"The Metric System: Past, Present—Future?" provides an insight into the role of measure in national affairs. A detailed history of interest in the metric system in the United States is given. A summary of this history is provided in "Historical Steps toward Metriation."

## **2. Teaching the Metric System: Activities**

Suggestions for introducing the metric system in the classroom are contained in "Experiences for Metric Missionaries." Conversion charts showing the relative sizes of metric units and their English counterparts are also included.

Ideas for making your own metric equipment are expressed in "Metric Equipment: How to Improve." The article also explains how to subdivide a line segment into ten equal parts.

"Think Metric—Live Metric" emphasizes the importance of estimating metric measures and provides a series of charts for recalibrating common

household measuring devices to the metric system. Sample test items for judging your own ability to apply the metric system are also included.

Games can be exciting tools for teaching both metric facts and metric measuring skills. "Procedures for Designing Your Own Metric Games for Pupil Involvement" lists principles for making such games and gives an example of a game involving weighing objects in kilograms.

The section concludes with samples of activities and worksheets relating to the metric system that have appeared in the "Ideas" department of recent issues of the *Arithmetic Teacher*.

### 3. Teaching the Metric System: Guidelines

Six ideas for converting a school curriculum to the metric system are contained in "Schools Are Going Metric."

The NCFM Metric Implementation Committee suggests both general and specific guidelines for teaching measurement and the metric system in the article "Metric: Not *If*, but *How*."

Placement of metric-system topics and skills in the elementary and secondary curriculum is discussed in "Teaching the Metric System as Part of Compulsory Conversion in the United States."

"Metric Curriculum: Scope, Sequence, and Guidelines" expands the ideas of the two previous articles. A sequence of topics relating to the metric system is suggested for primary, intermediate, and secondary levels. Teaching guidelines are also presented.

### 4. Looking at the Measurement Process

What skills are necessary for measuring? "Ten Basic Steps for Successful Metric Measurement" considers basic skills and suggests a natural sequence for their development.

"Thinking about Measurement" reviews the work of Piaget with respect to measurement and suggests specific teaching activities that are consonant with Piaget's findings.

Actual measurements are approximations. The article "Teaching about 'About'" suggests that a measurement is between bounds and develops an arithmetic for these bounds.

### 5. Metrication, Measure, and Mathematics

This article considers measurement as a mathematical function, and explores several measure functions. Psychological difficulties and considerations in the teaching of measure functions and the applications of measure functions to metrication are considered. Teaching suggestions conclude the paper.



*Introducing the Metric System*

# Activities for introducing metric concepts to teachers

JON L. HIGGINS

The best way to learn about the metric system is to use it! Here are some sample activities that show you some of the advantages of the system. They are restricted to activities that use simple materials. As you work through them, you should consider how they might be adapted to use other materials, either commercial or teacher made, and if they are suitable to the age or grade level you teach.

## Work Card #1: Arbitrary units

Find a textbook. Measure its length using your index finger as a length unit. How many fingers long is the book?

Now pass the book to a neighbor. Have him measure the length of the book using the length of *his* index finger as a unit. How long does he say the book is?

How do your two measurements compare?

Is there a problem if the book is not a whole number of fingers long? What might you do to help solve the problem?

## Work Card #2: Parts of units

Use the same textbook you used for work card #1. Measure its width using the length of your index finger. What is its width to the nearest whole finger?

Now measure the width of the textbook using as a basic unit the width of your thumb. What is the width of the textbook to the nearest whole thumb?

If you are restricted to whole-number measurements, which do you think is the better measure to use, fingers or thumbs?

Imagine that you measured the width of the textbook using the thickness of your fingernail as the unit of length. Which would be the best measure to use, fingers, thumbs, or fingernails?

What are the disadvantages of using fingernail thicknesses as length units?

Could you improve the process by using some combination of finger, thumb, and fingernail units? What rules might you have to make to be sure different people could get the same finger, thumb, and fingernail measurements for a given book width?

**Work Card #3: Fractional units**

It may be more accurate to measure with smaller units, but most people get tired of counting the big numbers that result. A good compromise is to use a big unit that is subdivided into smaller fractional parts. One can use the big unit to measure most of the length and count only the fractional parts for the last partial unit of length.

At the bottom of this work card are big units that have been divided into fractional parts. The name of the big unit is the *awkward*.

How many fractional parts make one awkward?

Can you name one of the fractional parts? (You may want to make up a name of your own for this subdivision. Be creative!)

Measure the length, width, and thickness of a textbook, to the nearest fractional awkward.

Pass the book to your neighbor and compare measurements. Do they match? Why or why not?

**Work Card #4: Computed measures**

Imagine a square piece of paper one awkward on each side. How many of them could you lay on top of the textbook? Make a guess to the nearest whole square awkward.

Calculate the area of the top of the textbook in square awkwards by multiplying the length in awkwards by the width in awkwards.

How does your calculation compare with your guess?

If your length and width measures included fractional parts of an awkward, your area measure should include some fractional parts of a square awkward. If you use only the subdivisions shown on work card #3, what would be the smallest fractional part of a square awkward?

Calculate the volume of a box that would hold the textbook by multiplying together the length, width, and thickness of the book (all in awkwards). Your answer is the number of awkward cubes that would be required to fill such a box.

Construct a cubic awkward. Does your answer for the volume of the textbook box look reasonable in terms of the cubic awkward? How could you check your work?

What is the smallest fraction of a cubic awkward you could possibly obtain if you use only the subdivisions of the awkward shown on work card #3?

Could we have made a better choice of fractional parts when dividing the awkward?

**Work Card #5: Introducing the decimeter**

Previous work cards have explored two problems: the necessity to agree on a standard unit of length instead of arbitrary units, and the advantages and disadvantages of different schemes for subdividing units into fractional parts. The bottom of this work card is ruled in a length unit that solves both these problems. The unit is a standard that is widely agreed on, and the unit has more convenient fractional parts than the awkward. See if you can find out why its fractional parts are easier to work with.

Measure the length, width, and thickness of a textbook with this ruler.

Compute the area of the top of the book in square decimeters. Write your answer in both fractions and decimals.

Compute the volume of a box that would just hold the textbook.

If lengths, widths, and thicknesses are measured to the nearest tenth of a decimeter, what will be the smallest fractional part of a square decimeter that can be calculated? What will be the smallest fractional part of a cubic decimeter that can be calculated?

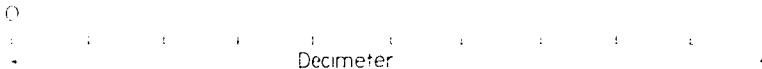
**Work Card #6: A bigger measure**

Measure the height of your neighbor using the decimeter scale from work card #5. (One convenient way to do this is to first mark his height on a strip of adding-machine tape; then measure the distance between the mark and the end of the tape.)

Would a different length unit be more convenient for measuring the heights of different people?

Suppose you invented a bigger length unit, but used the decimeter as the fractional part of this new unit. Remembering what you know about computing with fractions and decimals, how many decimeters should you choose to make one of the new length units? Explain your answer.

A length unit that is ten decimeters long is called a *meter*.

Using the decimeter scale on work card #5, construct a meter on a piece of adding-machine tape.

Find the length and width of your room in meters.

Calculate the area of the floor of your room in square meters.

**Work Card #7: Smaller measures**

Measure the length and width of a business calling card. You may use either the meter from work card #6 or the decimeter from work card #5. Which would be the better choice?

Would it be more convenient to define a unit of length smaller than the decimeter? Could you use your knowledge about the meter and decimeter to define this smaller unit? How might you do it?

A smaller length unit is ruled on the bottom of this work card. How does it compare to the decimeter scale on work card #5?

The name of this smaller unit length is the *centimeter*.

Use centimeters to measure the length and width of the calling card.

Use centimeters to measure the length and width of a paper clip.

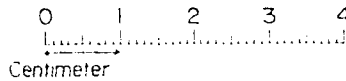
**Work Card #8: Relating measures**

Measure a length of one meter on a strip of adding-machine tape. Now remeasure this length using the decimeter scale from work card #5. Complete these equations using decimal notation:

1 meter = \_\_\_\_\_ decimeters; 1 decimeter = \_\_\_\_\_ meter

Use the centimeter scale from work card #7 to measure a length of one decimeter. Complete these equations:

1 decimeter = \_\_\_\_\_ centimeters; 1 centimeter = \_\_\_\_\_ decimeter

1 meter = \_\_\_\_\_ centimeters; 1 centimeter = \_\_\_\_\_ meter

If we want to measure even smaller lengths, it is convenient to give a name to the fractional part of a centimeter. This tiny length is called a *millimeter*. Make a table of equations relating the millimeter to the centimeter, decimeter, and meter.

If we want to measure bigger distances, we could invent a bigger length unit that has a meter as its fractional part. The most commonly used big length unit is the *kilometer*. A kilometer is 1000 meters. A meter would be what fractional part of a kilometer?

Make a table of equations relating the kilometer to the meter, decimeter, centimeter, and millimeter.

**Work Card #9: Exploring volumes**

Use light cardboard to make a box that is 1 decimeter long, 1 decimeter wide, and 1 decimeter high. Leave the top of the box open.

What is the volume of this box in cubic centimeters?

Fill a one-quart milk carton with rice. Pour the rice into the cubic decimeter box. Is the volume of the box more or less than one quart?

Use a one-cup measure and rice to estimate the volume of the box in cups. Report the volume of the box as being less than ..... cups and more than ..... cups.

This box is a convenient measure of volume, and it has the advantage of being closely related to the units of length you have just worked with. The name of the volume of the box is one *liter*.

**Work Card #10: Exploring weights**

If we fill one cubic centimeter with water we can invent a small unit of weight. This weight unit is called a *gram*.

The United States nickel weighs about 5 grams. Use a balance and a nickel to find the weight in grams of one sheet of paper. (If the sheet of paper weighs less than the nickel, and you cannot cut the nickel up, what else can you do to solve this problem?)

What is the weight in grams of an entire ream of paper?

If a liter box is filled with water, how much would it weigh in grams?

One thousand grams is used as a big unit of weight, called the *kilogram*. What is the weight of a liter of water in kilograms?

Put a plastic bag inside the liter box you constructed for work card #9. Fill the bag (to the rim of the box) with water (always holding it over a sink). You are holding a kilogram. Have someone place books in your other hand until the books feel about as heavy as the kilogram.

What is the weight of each book according to your estimate?

How could you improve the accuracy of your estimate?

# Inching our way towards the metric system

GERARDUS VERVOORT

*As assistant professor of mathematics education at Lakeland University, Gerardus Vervoort's professional experience also includes teaching in elementary and secondary schools. He has worked with Indians and Eskimos and has taught school in three different countries. He grew up in the Netherlands and, thus, is used to thinking metric.*

What is heavier, a pound of gold or a pound of feathers?"

"They both weigh the same," answers the bright child in whom we have carefully nurtured logical thinking.

"Wrong!" we reply. "A pound of feathers is determined by avoirdupois weight and measures 7,000 grains. A pound of gold is determined by troy weight and measures 5,760 grains. Thus, a pound of feathers is heavier. Clear? Let us try once more. What is heavier, an ounce of gold or an ounce of feathers?"

"An ounce of feathers?"

"Wrong!"

"They both weigh the same?"

"Wrong again! A pound of gold consists of 12 ounces because it is determined by troy weight. Therefore, an ounce of gold is equal to 480 grains. But there are 16 ounces in an avoirdupois pound. Therefore an ounce of feathers equals 437.5 grains."

It should come as no surprise that many people in North America have ceased all critical thinking with respect to measurements. A full-page advertisement for a certain small car in the 18 October 1971 issue of *Newsweek* boldly proclaims that it has a fifty-seven inch overall outside width while it is a full five feet across on the inside! How many readers noticed the discrepancy?

Anyone who feels smug and confident

regarding his knowledge of the North American system of weights and measures is invited to test his mettle on the following questions:

1. How many cubic inches are there in a gallon?
2. What is the difference between a liquid quart and a dry quart?
3. How many square feet are there in an acre?
4. A common aspirin tablet is five grains. How many scruples does that represent?
5. What is the number of pennyweights in a troy ounce?

There will be few who can answer all of these correctly. Yet the list of questions could have been made much longer and more difficult by including references to rods, furlongs, square perches, poles, chains, cords, fathoms, cables, nautical miles, leagues, pecks, gills, drams, hogsheads, and barley corns. And it must not be overlooked that though a bushel generally represents 60 pounds avoirdupois, it is equal to only 48 pounds of barley, 32 pounds of oats, or 56 pounds of rye or Indian corn. And do not forget the regional differences. In Massachusetts a bushel of potatoes is 60 pounds, but only 56 pounds in North Carolina or West Virginia.

Is it any wonder that 14 countries are presently preparing to GO METRIC and join the 114 countries and territories that have adopted the metric system already? Increasing world trade and the fact that Britain is in an advanced stage of change-over from the inch-pound to the meter-gram system, makes a similar change mandatory for the economic survival of the few remaining nonmetric countries. Most think as Canada:

The Government believes that adoption of the metric system of measurement is ultimately inevitable—and desirable—for Canada. It would view with concern North America remaining as an inch-pound island in an otherwise metric world—a position which would be in conflict with Canadian industrial and trade interests and commercial policy objectives. The Government believes that the goal is clear, the problems lie in determining how to reach this goal so as to ensure the benefits with a minimum of cost.

If such governments are correct in their assessments, then the need to begin this process of change as quickly as possible is obvious. The longer the decision is delayed, the more the eventual cost of the change will be increased.

The implications for the educational system are clear. The children presently in school will be in their early thirties in the year 2000. Presumably, the whole world will be metric by that time. Inches, pounds, and yards will have gone the way of the fountain pen, the kerosene lamp, and the log cabin—picturesque memories of the past, surviving in a few standard expressions and in museum exhibits, but otherwise of historical interest only.

In preparation for that time, there is an immediate need for greater emphasis on teaching the metric system and a consequent need for retraining teachers and revising the textbooks. This is urgent already because of the years that elapse between the introduction of new texts and the graduation of the students who have used them.

As soon as primitive men learned to speak and communicate, a need for exchanging quantities must have arisen. No

doubt first expressions were vague and inexact, but they served a purpose, just as similar statements of measurement serve a purpose today. We are still told to gather an “armful” of wood, and to add a “handful” of flour or a “pinch” of salt to a certain cooking recipe. The grocery store may advertise that a “truckload” of watermelons has arrived just in time for the weekly special. The term *truckload* serves a purpose because no one, except the store keeper, cares whether that means 600 watermelons or 1000.

All these measurements are easy to visualize and often directly related to physical experiences. A nomadic Eskimo reckons distances by so many “sleeps.” A German farmer may explain that he owns six “mornings” of land, meaning the land area that can be plowed by a man in six mornings. We do comparable things in North America when we measure distance by stating that it is a “three-hour drive” or when we measure areas by “city blocks.” Sometimes such measurements survive in our language even though they can no longer be easily visualized. Electoral districts are sometimes called “ridings” from the distance a man could cover on horseback. And just as primitive man developed new measures as the need arose, so do we. We talk about a “pack” of cigarettes and a “roll” of paper towels.

However, such inexact measures were not sufficient for trade or barter—they left too much room for disagreement because they meant different things to different people. Even where agreement existed, it still could be very confusing. For example, a last (load) of herring was 12 kegs, but a last of gun powder was 24 kegs. A last of brick was 500 bricks, but a last of tiles was only 144 tiles. A last of wool was 12 sacks.

If one goes to a market place in Europe, one can still buy goods by the *ell*. An ell of cloth is a length of cloth stretched between the hand and the shoulder (this measure survives in our word *elbow*), but when purchasing by the ell, watch the



salesman closely to see that he indeed stretches his hand and arm completely while measuring your purchase. Preferably buy from people with long arms, and under no circumstances buy elastic that way.

To make trade possible, local barons and chieftains often established certain standards of measurement. Their foot was always a popular standard. So was their thumb. A certain Anglo-Saxon king defined the yard as the length of his girth. Picture the foot, thumb, and waist measuring ceremonies. Imagine all the resulting confusion. For not only did these measures differ from place to place, but they changed with the advent of any new ruler. And life expectancy was rather short in those days.

As long as trade occurred primarily at the local level, the situation was not disastrous. People did not question why cloth should be measured by the ell, land by rods, and a horse's height by hands. And before the Arabic numerals were used, converting from one measure of length to another was difficult regardless.

With the growing acceptance of the decimal system of numeration, the beginning of science and industry, and the development of more powerful national governments (who were interested in the flow of goods for purposes of taxation), the situation changed. Voices became adamant in favor of a more rational system of measurement; one that not only would be universal, but in which the units of length, area, and capacity would be related in a simple manner.

If the new system was to be truly universal, with all measures related as much as possible, then the selection of a basic unit was important. Several possibilities were considered. The time of the swing of a pendulum is directly related to its length. The length of a pendulum that would describe one complete swing per second was suggested as the fundamental unit of the new linear measure. But that would hardly be universal, critics pointed out: a pendulum swings faster at the north and south poles than it does at the equator. Moreover,

a measure defined in that way would presuppose a definition of a second which was in itself a questionable measure.

A sector of the equator was also suggested as a unit. But the length of the equator would be difficult to measure. Besides, few countries touch the equator; thus, the new measure would not be truly universal.

Finally, a third proposal was agreed on: a portion of a meridian would be used as a general standard. Although few countries were on the equator, every nation was on some meridian. (It was generally accepted at that time that every meridian was of exactly the same length as any other meridian, a belief that was later proven wrong.) But what portion of the meridian should be used? One millionth, a ten-millionth, a hundred-millionth? Practical aspects of daily life, as well as trade and commerce, had to be taken into consideration. Since the approximate circumference of the earth along a meridian was already known from astronomical calculations, and because dividing that length by 40 million would yield a length of about one yard, that was the unit decided on for the basic measure. The new measure was called the *meter* (in French, *metre*—from the Greek *metron*, "measure"). In turn the basic measure was increased or decreased by powers of ten to establish other linear measures. Greek prefixes to the term *meter* were used to denote multiples of the unit, while Latin prefixes indicated subdivisions.

The result was as follows:

1 kilometer	=	1000 meters
1 hectometer	=	100 meters
1 dekameter	=	10 meters
1 meter	=	1 meter
1 decimeter	=	0.1 meter
1 centimeter	=	0.01 meter
1 millimeter	=	0.001 meter

For a unit of area, the square dekameter was decided on. A square meter would have been too small for practical purposes; a square hectometer, too big for a land where fields were small. A square 10 meters by 10 meters roughly equaled the size of a woman's herb and vegetable garden, thus

making it easy to visualize. The new unit of area was called an *are*.

At first glance one would expect an extension of this new measure by the proper prefixes to create the whole increasing and decreasing sequence. But a square equal in area to 10 are would have a length of  $10\sqrt{10}$  meters (approximately 31.6 meters), thus upsetting the simplicity of the system. Hence the only acceptable extensions of this measure are the following:

1 hectare	=	100 ares
1 are	=	1 are
1 centiare	=	0.01 are

Of course one can always speak of a square kilometer or a square meter if the needs require it.

The basic measure for volume (capacity) posed no great difficulty. Reason demanded that it be defined in terms of the meter. One cubic meter was clearly much too big (approximately 250 gallons); a cubic centimeter, too small. Hence the only reasonable choice was the cubic decimeter which is equal in capacity to about one quart. The new measure was called a liter (from the French *litre*). Again the derived measures followed the same pattern as the meter:

1 kiloliter	=	1000 liters
1 hectoliter	=	100 liters
1 dekaliter	=	10 liters
1 liter	=	1 liter
1 deciliter	=	0.1 liter
1 centiliter	=	0.01 liter
1 milliliter	=	0.001 liter

Convenient though the liter was for purposes of measuring liquids, it was not satisfactory in all cases. For instance, firewood—a cubic meter would appear a lot more reasonable. It was adopted as such and called the *stere* (from the Greek *stereo*, “solid”). The stere was used nearly exclusively for wood; and, as a result, no names for powers of the stere were ever adopted because there existed little need for them.

To us, living in the second half of the twentieth century, the unit of weight (more properly, mass) agreed on is surprising because it is so small. But at the time the unit

was selected, relatively few goods were sold by weight. Notable exceptions were precious metals and spices, which were sold in small quantities, of course, but which played a very important part in the economic structure of the country. And the scientists themselves often dealt in very small quantities in their laboratories. At any rate, the unit of mass selected was the mass of one cubic centimeter of water at its greatest density. This was called the gram (French *gramme*). Again the usual derivations were agreed on:

1 kilogram	=	1000 grams
1 hectogram	=	100 grams
1 dekagram	=	10 grams
1 gram	=	1 gram
1 decigram	=	0.1 gram
1 centigram	=	0.01 gram
1 milligram	=	0.001 gram

For the measure of angles, the traditional 90 degree angle was called a *grade*. It was divided into decigrades, centigrades, and milligrades. (It is for that reason that the term *centigrade*, as applied to temperature, is incorrect. It is more properly called Celsius, after the Swedish scientist Anders Celsius who created that particular temperature scale.) The renaming of angles never caught on, however, due to the cumbersome fractions involved. For instance the traditional 60 degree angle became 66 $\frac{2}{3}$  centigrades. It is clear that this change was no improvement.

The metric system originated in France during the period of the French revolution. What hampered the acceptance of the metric system in non-French countries most, however, was the excessive zeal displayed by the metric creators in other areas. They began an entirely new calendar starting with the year one. They fashioned a new “week” of ten days duration, thus doing away with the Sabbath. As a result, the whole metric system came to be associated in the eyes of many with a “godless atheism,” a system “conceived in sin and born in iniquity,” as some put it. Combine this with a common veneration for matters old and familiar, and with the distastes of the English-speaking world for anything

French that resulted from the Napoleonic wars.

How long lasting and extreme this feeling could be was expressed by the periodical called *The International Standard* that was published in the 1880s by the Ohio Auxiliary of the International Institute for Preserving and Perfecting Weights and Measures. The president of the Ohio group, a civil engineer who prided himself on having an arm exactly one cubit in length, had this to say in the first issue:

We believe our work to be of God; we are actuated by no selfish or mercenary motive. We depreciate personal antagonism of every kind, but we proclaim a ceaseless antagonism to that great evil, the French Metric System. . . . The jests of the ignorant and the ridicule of the prejudiced fall harmless upon us and deserve no notice. . . . It is the battle of the Standards. May our banner be ever upheld in the cause of Truth, Freedom, and Universal Brotherhood, founded upon a just weight and a just measure, which alone are acceptable to the Lord.

A later edition combined religion and chauvinism beautifully in the song entitled "A Pint's a Pound the World Around." Following are some of the verses and the chorus:

They bid us change the ancient "names",  
The "seasons" and the "times",  
And for our measures go abroad  
To strange and distant climes.  
But we'll abide by things long dear,  
And cling to things of yore  
. . . . .

*Chorus:*

Then swell the chorus heartily,  
Let every Saxon sing:  
"A pint's a pound the world around",  
Till all the earth shall ring.  
"A pint's a pound the world around",  
For rich and poor the same:  
Just measure and a perfect weight  
Called by their ancient name!

Now Great Britain has discarded the inch-pound system and Canada has declared its intention to go the same way. The time for decision in the United States has come. On 6 August 1971 Mr. Claiborne Pell, the Senator from Rhode Island, introduced a bill (S.2483) to Congress "to provide a national program in order to make the international metric system the official and standard system of measurement in the United States and to provide for converting to the general use of such system within ten years after the date of enactment of this Act." The bill has been passed by the Senate. The ultimate decision to go metric appears inevitable. Teachers would do well to start acquainting their students with the system more thoroughly than in the past. THINK METRIC should be the slogan in the teaching of measurement for the child who will spend most of his adult life in the twenty-first century.

### References

- Arnold, C. J. "An Answer to 'Arguments Against Universal Adoption of the Metric System.'" *School Science and Mathematics* 51 (April 1951): 310-15.
- Donovan, F. *Prepare Now for a Metric Future*. New York: Weybright & Talley, 1970.
- Drews, R. M., and Chauncey D. Leake. "The Metric System—Pro and Con." *Popular Mechanics* 114 (December 1960): 138-39.
- Herbert, E. W. *The Concise Metric Converter*. Winchester, England: Prentice Press, 1970.
- Read, Cecil B. "Arguments against Universal Adoption of the Metric System," *School Science and Mathematics* 50 (April 1950): 287-306.
- Swan, Malcolm D. "Experience Key to Metric Unit Conversion," *Science Teacher* 37 (November 1970): 69-70.
- White Paper of Metric Conversion in Canada*. Ottawa, Ont.: The Queen's Printer for Canada, 1970.

# The metric system: past, present—future?

ARTHUR E. HALLERBERG

*As professor of mathematics at Valparaiso University in Valparaiso, Indiana, Arthur Hallerberg teaches mathematics content courses for preservice elementary and secondary school teachers. He was the editor of the NCTM's Thirty-first Yearbook, Historical Topics for the Mathematics Classroom.*

The wife's query in an old cartoon gets right to the point: "Well, why on earth don't we adopt the metric system if it's so much better?" The husband's response is equally direct: "Why, just because we never did, my dear!"

It is unlikely that any simpler explanation, enigmatic yet revealing, could be given to summarize the introduction of the metric system in the United States. One should not be surprised that this cartoon first appeared over twenty-five years ago (Committee on the Metric System 1948, p. 4). It could have appeared twenty-five or fifty years before that. And twenty-five years from now, will proponents for the increased use of a system still uncommon in the United States point in similar futility to this same cartoon? There is evidence to the contrary.

This brief paper will endeavor to give teachers of mathematics some of the relevant background on the present status of the metric system in the United States and other countries. While we will include some reference to the problems that must be faced in *metrication* (the word used by the British to describe the process of converting or changing over to the metric system), this paper reflects the official position of the NCTM which "encourages the universal adoption of the metric system of measure."

1948 the Twentieth Yearbook of the

NCTM was devoted exclusively to documenting the desirability of officially adopting the metric system in this country. In three of the last four years, NCTM Delegate Assembly resolutions have focused on the metric question; these have been accepted by the Board of Directors and referred to the appropriate committees. The 1972 resolution urges "that the NCTM continue to support the adoption of the metric system and encourage that this be a system to be taught by teachers of all grades, along with other systems of measurement, beginning in the 1973-74 school year."

## Early measurements

In 1890 J. W. L. Glaisher said, "I am sure that no subject loses more than mathematics by an attempt to dissociate it from its history." Certainly we show no disrespect to mathematics if we restate this by substituting measurement in general, and the metric system in particular, in this dictum. The history of measurement includes practical origins, theoretical aspects, cultural sidelights, and pedagogical implications.

We teach our children that the process of measurement assigns a number to some physical characterization of an object. It may be a characterization of length, volume, capacity, mass, or weight. To do this

we must begin with a *unit* that exemplifies the same characteristic that we wish to measure. By determining how many of these units are "contained" in the object or quantity to be measured, we arrive at the appropriate number, or *measure*, of the object.

The earliest units of length found in recorded history clearly indicate that man found it convenient and simple to use his own person for defining, and indeed supplying, measuring units. The interesting story of the historical development of measures and weights cannot be detailed here. But certainly our children should hear of the cubit and the fathom, the thousand paces, and the "three barleycorns round and dry from the middle of the ear."

In early times the relative size of the object to be measured determined the choice of a larger or smaller unit as the measuring stick. If one measures the length of an object with some particular unit, it is unlikely that the unit measure will be contained an exact whole number of times in the given length. Eventually, simple rounding off of such a measure could not be tolerated and the use of a "smaller unit" was needed to give a more careful reading. The seemingly natural relations between certain of the different basic units undoubtedly sufficed for a time (hand = 4 digits, yard = 3 feet), but the basic principle of subdividing a given unit into a certain number of equal subunits was the inevitable refinement.

Although each person had his own built-in measuring system, the units varied from individual to individual. If barter or purchase involved a specified number of such units, unequal sizes of the unit presented obvious difficulties. It was natural that persons of the same community would agree on certain standards reasonably accessible to everyone. As commerce grew and man became more mobile, the need for standards acceptable to larger groups and geographical areas became obvious. Again, the early development of *standard* units of various measures is a story too

involved to give in any detail here (American National Standards Institute, pp. 7-14). For our purposes, we pick up the story at two related points in history.

### The Jefferson plan

The United States Constitution, as adopted in 1788, provided that Congress should have the power "to coin money, . . . and fix the standard of weights and measurements." Prior to this, under the leadership of Thomas Jefferson and Robert Morris, the Congress of the Confederation had adopted the dollar as the fundamental monetary unit, based on the Spanish piece of eight. So that parts and multiples of the fundamental unit would be in an easily calculated proportion to each other, the decimal ratio was clearly favored. So in 1786 a completely *decimal* system of coinage was approved by Congress, and by 1792 the coinage system was finally implemented with the establishment of a mint.

In 1790 Thomas Jefferson, as Secretary of State, was requested to prepare a similar plan for a unified system of weights and measures. His response emphasized several features. The first was the need for an invariable standard of length. This he based on the pendulum principle—essentially, a cylindrical iron rod of such length that a swing from one end of its arc to the other and back again would take two seconds. This based the standard on the motion of the earth on its axis. For linear measure, this rod (about 58.7 inches) was to be subdivided into five equal parts, each to be one "foot." As a second feature, the system suggested was, like the coinage system, decimal in nature. The basic foot was to be successively subdivided, each time into *ten* parts, forming inches, lines, and points. Similarly, 10 feet were to equal 1 decade; and derived larger units, all based on successive multiplication by ten, led to rods [*sic*], furlongs, and eventually to the mile (10,000 feet).

The ounce was to be the basic unit of weight, derived from the weight of a cubic inch of rainwater. Again, the multiples

and subdivisions were all decimally arranged, with a pound equal to ten ounces. (A cubic foot of water would thus be divided into one hundred new pounds of ten ounces each.)

Jefferson's plan was discussed by Congress over a period of six years, but no laws were passed as a result of his work. Although Jefferson used some of the same names (inches, feet, ounces, pounds) for his new units, which were not too far removed in size from the old units they were to replace, the division of the foot into ten inches and the pound into ten ounces may have been a part of the reason for hesitation on the part of Congress. Another reason, undoubtedly, was the discussion of a new measurement system that was concurrently taking place in France.

It should be noted that Jefferson's plan involved three important principles: (1) the standard unit of length should be based on some unchanging, absolute standard found in the physical universe; (2) the basic units of length, volume, and weight should be directly related to each other; and (3) the specifically named multiples and subdivisions of the standard units should be decimally related. In presenting a plan based on these ideas, Jefferson was following the same principles previously advanced by scientists and mathematicians elsewhere in the world. Our attention turns to an earlier time, across the ocean.

### The beginning of the metric system

By the late middle ages a complex assortment of measuring systems had been in use throughout all of Europe. Intense provincialism and the pressure of tradition contributed to this, as did the custom to give measurements in the units unique to the object to be measured. Thus, land was measured in rods, horse's height in hands, depth of water in fathoms, diamonds in carats, and so on. For many years the state of trade and technology was such that society could function satisfactorily even with such variations.

seventeenth and eighteenth centuries indicated the need for a change. As men like Newton (in physics) and, later, Lavoisier (in chemistry) needed increasingly more accurate measurements to investigate and to substantiate their theories, existing scientific instruments were improved on, or new ones were invented. The need for international standards of measurement in communicating the results of research and study to scientists was obvious.

A final impetus for a reform of the system of measurement came at the time of the French Revolution when reminders of the feudal system and of kings who ruled by divine right were to be discarded. Wide variations existed in measurements, with accompanying errors, frauds, and disputes. Fortunately, the change to a new system was made with serious regard for broad implications for the future. The three principles listed previously in connection with Jefferson's work were advanced in seeking a reform, with the added provision (in 1790) that the Royal Society of London was invited to join with the Academy of Science of Paris in deducing an invariable standard for all measures and all weights which could then receive uniform acceptance.

The French Academy began work immediately—fortunately, for the British never accepted the invitation—and proposed, first of all, a fully decimal-based system. Shortly thereafter they specified that the unit of length should be equal to one ten-millionth of an arc representing the distance between the North Pole and the equator (a quadrant of the earth's meridian). This standard unit of length was to be called the *metre* (we write *meter*), derived from the Greek *metron* "a measure." The basing of the standard on the length of an arc of some part of a great circle of the earth was first proposed in 1670, along with its decimalization, by the French abbé, Gabriel Mouton. He also suggested an equivalent definition based on the length of a pendulum that would beat 3,959.2 times in half an hour at Lyons, France.

Most scientific advances made during the

Preliminary calculations had already been made in 1739–40 when the land segment of the meridian passing through Paris with both ends terminating at sea level had been measured. This segment began on the northern coast of France at Dunkerque and ended at the Mediterranean Sea at Barcelona, Spain. It was the longest length of an accessible arc available in Europe, approximately 9 degrees and 30 minutes. The preliminary calculations made in 1740 supplied a provisional form of the meter which was to be used for almost ten years. In 1793 a provisional kilogram was also adopted—the weight in a vacuum of 1 cubic decimeter of distilled water at the freezing point.

From 1792 to 1798 a second survey of the arc was accomplished, though only under the most adverse circumstances. Also at this time, additional experimentation was carried out in the weighing of water at various temperatures, since temperature affects density. Thus in 1799, the provisional meter and kilogram were replaced by the newly established standards. (The provisional meter was  $\frac{1}{3}$  millimeter too long.) A standard meter and a standard kilogram were constructed of platinum and deposited in the Institut National des Sciences et des Arts.

The activities in France during the 1790s coincided with the placing of Jefferson's plan before the U. S. Congress. Special committee reports to Congress spoke of the plans of the French, and although they noted the desirability of uniformity in measures and weights of all commercial nations, they did not recommend a change in the existing measures in the United States. In 1795, copies of the French provisional meter and kilogram were sent to the U. S. Government in an attempt to obtain true international uniformity. But the prevailing political conditions of that day (the United States had refused to take sides in a dispute between the British and the French at that time) did not offer a favorable climate in Congress. This, together with the Jefferson proposal and the traditional viewpoint that

advocated no change, resulted in no action whatsoever by Congress.

To accompany the establishment of the metric system in France, all European countries were invited in 1798 to send representatives to Paris to learn of the system so that it might be accepted ultimately as an international standard. Although none of the nine countries that responded to the invitation adopted the system at that time, the educational impact of this effort was to be felt at a later time.

France itself did not achieve immediate success with its new system. Mandatory though it was, it could not be enforced, since secondary standards had not been distributed to the various governmental agencies throughout the country, let alone the commercial and household users. The situation was further complicated in 1812 when Napoleon Bonaparte issued a decree establishing a system of measures termed *usuelle*, based on the metric system but using old unit names and ratios rather than the decimal system. The confusion resulting from the increase in the number of measures was so great that in 1837 an act was passed abolishing the *usuelle* system and returning to the original decimal metric system. By 1840 the mere possession of old style weights and measures was punishable to the same degree as their illegal use. Thus, the conversion was to be effected.

### The Adams report

During the early 1800s, the Congress of the United States was preoccupied with matters pertaining to the growth and expansion of the country to such a degree that it still did not make provision for the uniformity of weights and measures provided for by the Constitution. In 1816 President Madison reminded Congress of this fact. Hence, a year later, President Monroe's Secretary of State, John Quincy Adams, was asked by the Senate to prepare a new statement concerning the regulations and standards which could be adopted in the United States. The *Report Upon Weights and Measures*, issued by

Adams in 1821, has become a classic in the history of the metric controversy in the United States. Its exhaustive treatment of the advantages and disadvantages of both the English and metric systems to the United States in 1821 was such that both proponents and opponents of the metric system were to turn to it for years to come in support of their positions. While the theoretical advantages of the metric system were described by Adams, the practicability of the system remained much in question. The altering of the system by Napoleon was an indication of the inability of the system to gain proper acceptance. Adams therefore recommended that, while the United States should confer with the governments of France, Spain, and Great Britain in the attempt to develop the principle of uniformity in weights and measures, any action that would be taken to achieve uniformity in the meantime should be within the framework of the British Standards.

The recommendations of the Adams report were a realistic response to the conditions existing in the United States in 1821. Unfortunately, at the same time, they were to preclude further consideration of the metric system for the next forty years. During those years the country would experience such great developments in transportation, commerce, and industry as to give it a feeling of independence from the need for international uniformity in any system.

### **Uniformity achieved**

While no action of any sort was immediately taken by Congress in response to the Adams report, within ten years another clause of the Constitution was to have its effect. In 1830 the Secretary of the Treasury was directed to make a comparison of the standards of weights and measures used in the principal custom houses of the United States. The wide variation in these standards, which were used for purposes of taxation, clearly indicated a direct violation of another section

of the Constitution, that "all duties, imposts, and excises shall be uniform throughout the United States." The Treasury Department felt it had sufficient authority to correct this situation without further legislation, and, therefore, adopted the yard, the avoirdupois pound, and the Winchester bushel as the official units. The unofficial standard of length was based on a copy of the Troughton scale, an 82-inch bronze bar with an inlaid silver scale obtained from a London instrument maker in 1814. The distance between the 27th and 63d inches, representing 36 average inches of the bar, was taken to be equal to the British yard at 62 degrees Fahrenheit. During the period from 1836 to 1856, Congress provided that complete sets of standards of weights and measures should be supplied to all states and territories, and the individual states adopted these as their standards of weights and measures. Uniformity of measurements had been secured throughout the country!

But interest in the metric system was not completely dead in the United States. The activities of Alexander Dallas Bache, a great-grandson of Benjamin Franklin, reflected the continuing concern for a simpler, but more uniform system of weights and measures. In 1843 Bache was appointed Superintendent of the Coast Survey, and as such was responsible for the Office of Weights and Measures. In various reports to Congress, he noted that the current arrangement of weights and measures was "deficient in simplicity and in system" and argued for the universal uniformity of weights and measures.

The attention of Congress to the problems of the Civil War period gave low priority to these and other plans for the adoption of the decimal system. In 1863 the National Academy of Sciences was established by an act of Congress. Its first president was the same Bache, who was to see that its first established committee was on Weights, Measures, and Coinage. A standing committee of similar name was created by the House of Representatives



in 1864. This committee initiated legislation that, in 1866, made it lawful throughout the United States of America "to employ the weights and measures of the metric system." While a date by which the use of the system should become mandatory was not included, it was anticipated that after a short period a further act would fix the date for its exclusive adoption.

Shortly thereafter steps were taken abroad for the establishment of an improved international metric system. In 1875 the "Treaty of the Meter" was signed in Paris by seventeen nations, including the United States. This provided for the establishment of a permanent International Bureau of Weights and Measures with headquarters near Paris, and for the fabrication of new international prototypes. In 1890 the United States received prototype meters No. 21 and No. 27 and prototype kilograms No. 4 and No. 26. Three years later, by administrative action of the Superintendent of Weights and Measures, these were declared to be the nation's fundamental standards of length and mass; and the units of the English customary system were defined by carefully specifying what fraction of a meter would constitute a yard and what fraction of a kilogram would constitute a pound.

While the preceding account summarizes the positive action in establishing national standards of measure in the United States, it by no means covers the entire story of the proponents and opponents for the adoption of the metric system in this country.

### The metric controversy

The history of the metric system controversy in the United States has recently been published as one of the substudies of the U. S. Metric Study (Treat 1971).

Perhaps the longest running debate in the history of this country is whether the United States should convert to the metric system. In the course of almost two centuries dozens of arguments have been advanced, attacked, and defended with a passion inspired by a topic with implications that are both intensely practical and

intellectually stimulating (De Simone 1971, p. 35).

The substudy report records, in fascinating detail and with complete documentation, this debate, which has been held not only in the committee rooms of Congress, but also in educational institutions and publications, scientific societies, engineering organizations and trade journals, boards of commerce and trade, and in the public press.

Some idea of the focus of interest and time element involved is obtained from the following listing of the major periods of activity treated by historian Charles F. Treat.

1. The period of consolidation (1786–1866)
2. The educational movement (1886–1889)
3. The movement to introduce the metric system through government adoption (1890–1914)
4. The propaganda period (1914–1933)
5. The comprehensive study phase (1934–1968)

A summarizing paragraph for one of these periods—it happens to be that of 1914–1933, although, as indicated, it would do about as well for any of the previous periods—is the following:

For the most part, the arguments used by both sides during this period were simply modernized versions of those that had been advanced for decades. The proponents continued to insist that the metric system was superior, that it should be adopted in the interests of international uniformity, that the costs and difficulties involved in adopting it would be surprisingly slight, and that the eventual displacement of all other systems by the metric system was inevitable. Furthermore, it was said, the maintenance and improvement of our foreign trade depended upon metric adoption. The opponents of the system claimed that the United States had already achieved greater uniformity and standardization using the customary English System than was enjoyed by any other nation on earth, that the size of our foreign trade was in no way related to our system of weights and measures, and that changing over to the metric system would be confusing, costly, and not productive of corresponding benefits. In addi-

tion, the opponents claimed that what appeared to be a popular clamor for metric adoption was really an artificial demand that had been generated by insidious pro-metric propaganda (Treat 1971, pp. 227–28).

### Recent developments

Events over a period of ten years added a sense of urgency, lacking before, that were to culminate in 1968 in the most significant investigation requested by the U.S. Congress.

1957 *The launching of the Soviet Union's first Sputnik.*

This created new interest in scientific education and research.

1958 *The U.S. House of Representatives created a standing Committee on Science and Astronautics.*

The committee was given jurisdiction over standardization of weights and measures and the metric system.

1959 *The customary standards were officially defined in terms of metric units.*

Countries using the customary units, including the United States and the United Kingdom, defined the yard to be 0.9144 meter (1 inch = 2.54 centimeters) and the avoirdupois pound as 0.45359237 kilogram.

1960 *The Eleventh General Conference on Weights and Measures (of which the United States is a member) redefined the meter.*

The "meter bar" was abandoned as the international standard of length, and a wavelength of light was substituted (1,650,763.73 wavelengths of the orange-red line produced by krypton 86 was defined as 1 meter). This new definition was a return to the original concept underlying the metric system, namely, that an immutable standard be found in nature. The new determination is accurate to 1 part in 100,000,000 and has the advantage of being reproducible in scientific laboratories throughout the world.

1960 *The Système International d'Unités (SI) was established.*

Adopted by the General Conference on Weights and Measures, it became the official system, with the basic units of meter, kilogram, second, ampere, kelvin, candela, and other units based on these.

1965 *Great Britain announced its intention to convert to the metric system within ten years.*

This was done after repeated requests by industry that the conversion be made, although it previously had been held that any conversion would have to be accomplished simultaneously with a conversion by the United States.

1968 *The U.S. Congress directed the Secretary of Commerce to undertake the U.S. Metric Study.*

The purpose of the study was to evaluate the impact on America of the metric trend and to consider alternatives for national policy.

In 1971, the Report of the U.S. Metric Study was transmitted to the Congress of the United States. The study was conducted by the National Bureau of Standards of the Department of Commerce. The report recommended "that the United States change to the International Metric System deliberately and carefully," and that "the Congress, after deciding on a plan for the nation, establish a target date ten years ahead, by which time the United States will have become predominately, though not exclusively, metric."

One of the most important recent developments to give urgency to metrication is the increase in internationalized engineering standards. Engineering standards (not to be confused with "measuring standards") are "norms" regulating size, weight, composition or configuration of products, and standardization of practices. The International Organization for Standardization (referred to as ISO—a similar agency, IEC, is concerned with electrotechnical matters) is a nongovernmental body "to promote the development of standards in the world with a view to facilitating international exchange of goods and services and to developing

cooperation in the sphere of intellectual, scientific, technological, and economic activity (American National Standards Institute, p. 36)." The American National Standards Institute (ANSI) is the U.S. member of both international organizations. The great majority of standards still remain to be developed. Thus, by expressing itself in metric units the United States has the opportunity to influence international standards negotiations with its experience and technology.

Closely related to such international standards is the matter of world trade. A relatively slight drop in our exports of "measurement sensitive" products could mean the difference between a favorable and an unfavorable balance of trade for the United States. The decision of Great Britain to go metric leaves the United States as the only industrialized nation that is not committed to metric conversion. Canada has made the commitment, but has delayed implementation because of the close trade relations with the United States.

#### **The conversion act of 1972**

On 18 August 1972, the U.S. Senate passed on a voice vote the "Metric Conversion Act of 1972" (S. 2483). However, action was not taken by the House during the final weeks of the ninety-second Congress; so new action will be required in the next Congress.

Although chapter after chapter of the history of the efforts to convert the United States to the metric system has ended with the words "but no action was taken by Congress," there are strong indications that the last chapter is about to be written. Even though many important investigations and studies have been made at the request of Congress over the nearly two hundred years since the beginning of our country, the U.S. Metric Study carried out from 1968-1971 is something different. No previous study was preceded by so much discussion and careful consideration of the overall objectives that such a study should meet. No previous study was required to

be conducted with such breadth and depth in giving every sector of society an opportunity to express itself in public hearings and special investigations.

Though Congress will need to begin again on a new metric conversion act in 1973, some idea of possible legislation can be had by examining the 1972 Senate bill which reflected recommendations that emanated from the U. S. Metric Study.

1. It declared that it would be the policy of the United States to encourage the substitution of metric measurement units for customary units in all sectors of the economy with a view toward making metric units the predominant, although not exclusive, language of measurement within a period of ten years. (Note that the metric system is not to be the sole official, standard system of measurement—a football field may very well remain 100 yards long.)

2. It encouraged the development of engineering standards based on metric units where it would result in simplification, improvement of design, or increase in economy.

3. It recommended the establishment of an eleven-member Metric Conversion Board to oversee and implement the conversion process.

4. It recognized that federal procurement policies would have to be used to encourage general conversion to the metric system.

5. It called for programs for educating the public to the meaning and applicability of metric terms and measures in daily life, for assuring that the metric system of measurement becomes a part of the curriculum of the nation's educational institutions, and that teachers be appropriately trained to teach the metric system.

The following paragraph summarizes the U.S. Metric Study Report:

The cost and inconvenience of a change to metric will be substantial even if it is carefully done by plan. But the analysis of benefits and costs made in [this report] confirms the intuitive judgment of U. S. business and industry that increasing the use of the metric system is in

the best interests of the country and that this should be done through a coordinated national program. There will be less cost and more reward than if the change is unplanned and occurs over a much longer period of time (De Simone 1971, p. 117).

Metritication is indeed "a decision whose time has come" for America, and particularly for its educational institutions!

### References

- American National Standards Institute. *Measuring Systems and Standards Organizations*. New York: American National Standards Institute, n.d. (updated to 1970).
- Committee on the Metric System. *The Metric System of Weights and Measures*. Twentieth Yearbook of the National Council of Teachers of Mathematics. New York: Bureau of Publications, Columbia University, 1948.
- De Simone, Daniel V. *A Metric America: A Decision Whose Time Has Come*. U.S. Metric Study. Washington, D.C.: GPO, 1971.
- Treat, Charles F. *A History of the Metric System Controversy in the United States*. U.S. Metric Study, tenth substudy report. Washington, D.C.: GPO, 1971.

## Commonly listed advantages of the metric system

1. The metric system is a simple, logically planned system. Its decimal basis conforms to our numeration system.

2. The meter, which establishes the basis for the entire system, is always reproducible from natural phenomena and, therefore, is immune to destruction; it is international in character and well suited for precision work. The coordination of measures of length, area, volume and mass, combined with decimalization, facilitates computations.

3. Once the system of prefixes has been learned, the uniformity in names for all types of measures makes for greater simplicity and ease in changing to more convenient-sized units for specific purposes.

4. Although many of the claims of the amount of time that can be saved in learning fractions are probably exaggerated, less competence in the manipulation of common fractions would be required of many students, and some restructuring of time spent on such computation might be profitably accomplished. Ultimately, when only the metric system would be taught, time could be saved in the learning of conversion units (1 ft. = 12 in., 1 yd. = 3 ft., 1 rd. = 16½ ft., 1 mi. = 5280 ft., and so on) and in the learning of a second new system for use in science classes.

5. For ordinary work, familiarity with the meter, gram, and liter would be sufficient. However, for the engineer and the scientist, the new International System of Units (SI), based on the metric units, eliminates conversion problems in calculations with derived units. That is, although the meter is universally defined as work per unit

time, it is variously expressed in Btu/sec, therms/day, ft-lb/hr, horsepower, calories/sec, watts, and so on. The use of two different terms, *kilogram* and *newton*, for units of mass and force respectively, eliminates much of the confusion students have concerning these concepts.

6. Greater participation of the United States in the setting of international engineering standards would be possible since the metric system is the universal language of measure. Exports, foreign trade, and competition with other nations will depend more and more on production under metric standards.

7. A common measurement language that is used by scientists, engineers, and industrial workers would improve communication and reduce barriers between different sectors of society.

8. The necessity of conversion would offer fringe benefits. During the adjustment to the new measurements, there would be opportunities to eliminate superfluous varieties in sizes of products, parts, and containers, and to make additional worth-while changes in engineering standards, construction codes, and products design.

(It should be noted that men of honest persuasion have often listed statements contrary to those given here as advantages of the customary system. A comprehensive listing of both prometric and procustomary arguments is given in *A Metric America*. [Report of the U.S. Metric Study, 1971. Order by SD Catalog No. C 13.10:345, \$2.25, from Superintendent of Documents, U.S. Government Printing Office, Washington, D.C. 20402.]

Listed by ARTHUR E. HALLBERG,  
Valparaiso University, Valparaiso, Indiana

# Historical steps toward metrication

MARILYN N. SUYDAM

- 1670 Gabriel Mouton (a Lyons vicar generally regarded as the founder of the metric system) proposed a decimal system of weights and measures, defining its basic unit of length as a fraction of the length of a great circle of the earth.
- 1740 Preliminary calculations were made with a provisional form of a meter.
- 1790 A metric system of measurement was developed by the French Academy. *The need for a uniform system of weights and measures was noted and discussed in the U.S. Congress, but no action was taken.*
- 1795 France officially adopted a decimal system of measurement.
- 1798 A meeting was held in Paris to disseminate information about the metric system.
- 1799 The provisional meter and kilogram were replaced by newly established standards.
- 1821 *A document was issued by John Quincy Adams exhaustively listing the advantages and disadvantages of both the English and metric systems; Adams concluded that "the time was not right."*
- 1840 France made use of the metric system compulsory.
- 1866 *Legislation made it "lawful throughout the U.S. to employ the weights and measures of the metric system." The system was not made mandatory, although this was anticipated.*
- 1875 The "Treaty of the Meter," setting up well-defined metric standards for length and mass, was signed in Paris by seventeen nations, including the U.S. The International Bureau of Weights and Measures was established.
- 1880 Most of Europe and South America had gone metric.
- 1890 *The U.S. received prototype meters and kilograms.*

Adapted from materials published and copyrighted by the Agency for Instructional Television, 1974. Used by permission.

- 1893 *The metric prototypes were declared by the Superintendent of Weights and Measures to be the "fundamental standards" for the U.S.; other measures were defined in terms of the standard meter and kilogram. (Thus, the yard is legally defined as a fractional part of a meter and the pound as a fractional part of a kilogram.)*
- 1918--29 *Approximately forty bills on metrication were introduced in Congress, but no action was taken.*
- 1959 *Customary units were officially defined in terms of metric units.*
- 1960 *The meter was redefined in terms of a wavelength of light. The modernized metric system, the International System of Units (Système International d'Unités), referred to as SI, was established.*
- 1965 *Great Britain announced its intention to convert to the metric system.*
- 1968 *The U.S. Congress directed the Secretary of Commerce to undertake the three-year U.S. Metric Study, to evaluate the impact of the metric trend, and to consider alternatives for national policy.*
- 1971 *As a result of the metric study, it was recommended that the U.S. change to predominant use of the metric system through a coordinated national program.*
- 1972 *The Metric Conversion Act was passed by the Senate, but no action was taken by the House, so new action is required by Congress.*

*Teaching the Metric System: Activities*

# Experiences for metric missionaries

LOTTIE VIETS

*As assistant professor of education at Kansas State College, Pittsburg, Lottie Viets teaches methods for elementary school mathematics. She previously served as elementary supervisor in the Horace Mann Laboratory School at Kansas State College and has taught grade levels one through eight in Kansas public schools.*

For the past 180 years, the United States of America has been inching along toward the almost universally adopted metric system of weights and measures. Certain sectors of our society—science, medicine, engineering, and athletics—are in various states of transition at the present time. Some important developments and major decisions of the United States government regarding metrication, including a conversion date projected by the National Bureau of Standards, are shown in figure 1.

A Gallup Poll, prepared in August 1971 and published in October of that year, found that only forty-four percent of the adults in the United States knew what the metric system was; and of these, only forty-two percent were in favor of adopting it.

The survey also showed that among those who had attended college, eight in ten knew of the existence of the metric system; and of those who were aware of the system, their opinions favored adoption five to four. The former Secretary of Commerce, Maurice E. Stans, made this comment following the survey:

The poll confirms our own investigations which revealed that the more people know about metrication the more they favor its adoption. What is now needed is intensive education of the public on the significant benefits to be derived from the system.<sup>1</sup>

The evidence, therefore, is clear. There is an immediate need for education to

1. George Gallup, "Metric Support Grows," *Kansas City Star* (October 3, 1971): 5A.

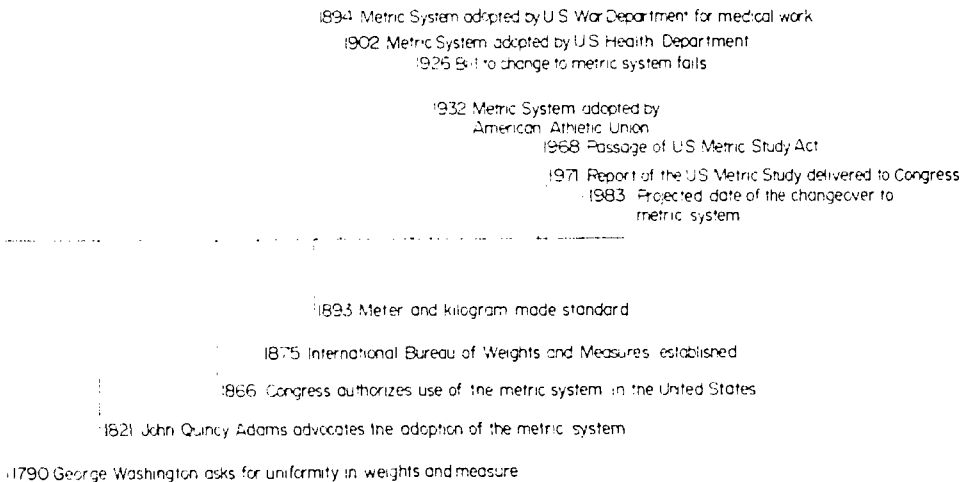

Fig. 1



prepare the public for metrication. This education can be done in large part through elementary school children who can carry the language, measurement experiences, computation exercises, and problem solving involving the metric system into homes in our country. It remains the responsibility of the school to give pupils the opportunities for measuring and estimating measures that Corle (1964) found necessary in his studies. It is the purpose of this article to suggest experiences that will aid teachers in accepting the challenge of educating children who can be metric missionaries in this period of conversion to another system of weights and measures.

The initial emphasis in instruction should be placed on teaching the fundamental units—meter, gram, and liter—and the prefixes that indicate the multiples and sub-multiples of ten. Charts and models showing basic terminology and the interrelationship of the basic units should be given permanent space for display for reference purposes in the classroom. The picture in figure 2 shows children making use of such materials.

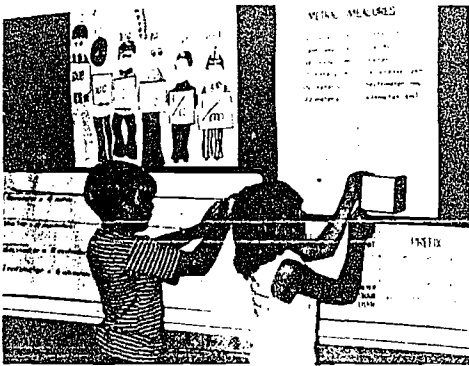

Fig. 2

To accomplish this beginning instruction, each child should be helped to develop a kit of the units of measure that includes materials like the following: string or ribbon the length of a meter, soda straws of a decimeter length strung with yarn to make a meter (can also be folded for decimeter lengths), centimeter lengths cut from soda

straws, centimeter grid paper for constructing the cubic centimeter and the liter. Heavy cardboard meter sticks can be constructed for home use. These can be kept at home with the usual yardstick and used as a measuring instrument for homework assignments and routine household measures.

Children should be given guidance in developing references or approximate measurements such as the following:

1 meter	Height or arm stretch of a kindergarten child Distance of the chalkboard from the floor
1 decimeter	Length of a piece of chalk Distance across face over eyes of a child
1 centimeter	Width of a finger Length of a bean or an eraser on a pencil
1 millimeter	Thickness of heavy tagboard
1 gram	Weight of a paper clip
2 grams	Weight of a sugar cube
5 grams	Weight of a nickel
1 liter	Capacity of gasoline tank of small lawnmower

Charts and displays like those in figures 3 through 7 show common equivalents that will be helpful for further reference while accommodating the English system of weights and measures.

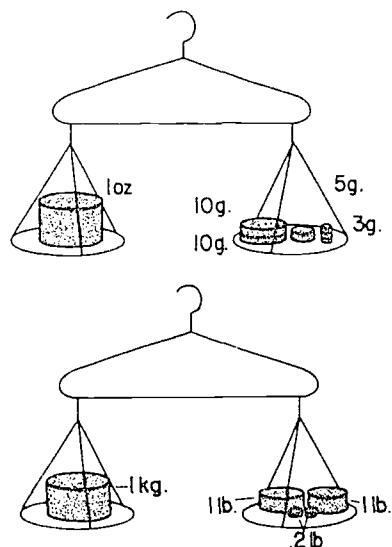

Fig. 3

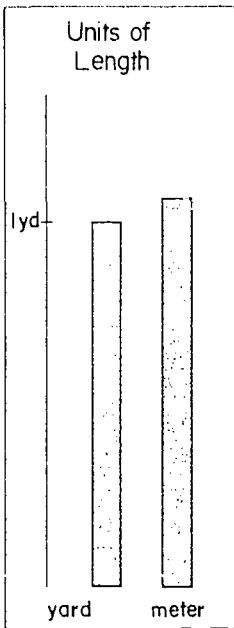

Fig. 4

Conversion charts from pounds to kilograms can be helpful for reference in individual graphing of weight in kilograms. The

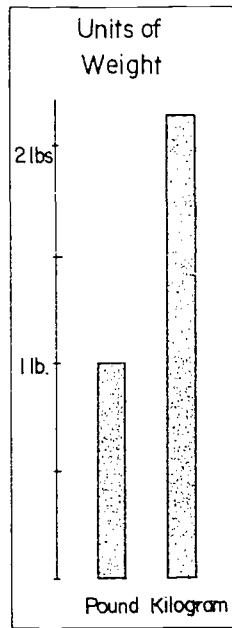

Fig. 6

graphs could be started at school and completed in the home at regular intervals throughout the school year. The classroom graph in figure 8 shows the number of pupils in weight ranges to the nearest kilogram. It should provide assistance to pupils in preparation of their individual graphs.

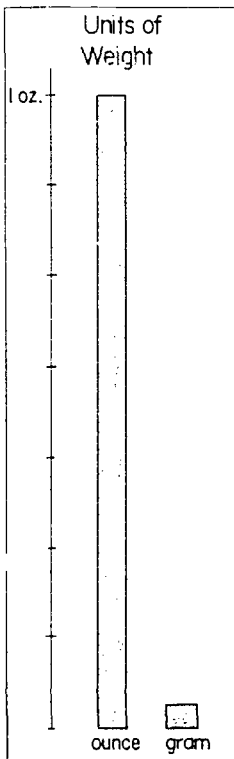

Fig. 5

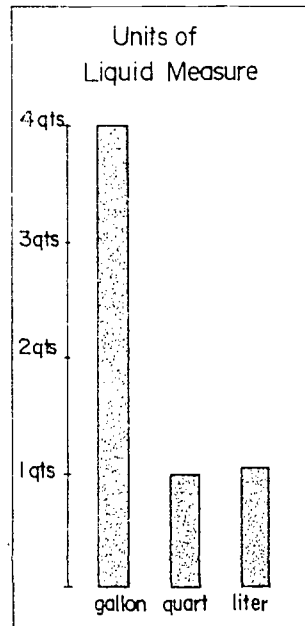

Fig. 7

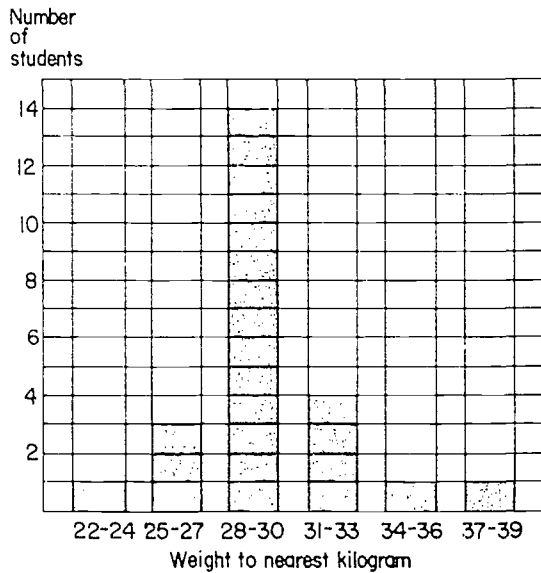

Fig. 8

Children enjoy using an illustrated measuring tape mounted on the classroom wall to check their heights in centimeters for later use in making graphs. The picture in figure 9 shows children measuring their heights. Charts of average heights that are displayed in the classroom for comparison purposes also appear in the picture. Each child can also be helped to prepare one of the measuring tapes for his home use. Adding machine tape is suitable for this project.



Fig. 9

The reference measurements listed earlier could be put to use in estimating for solving problems like the ones that follow:

How many meter lengths of fabric would be needed to make each girl in the first grade a long dress for the school program?

There are 48 grams of sugar left in the box. How many people can be served at a tea if each person uses one sugar cube?

Homework assignments might require pupils to locate labels indicating weights and measurements in metric language. The following are examples:

1 box gelatin	85 grams
1 box soda crackers	198 grams
1 can soup	298 grams
1 bottle vinegar	355 cubic centimeters
1 can vegetable juice	177 milliliters

Other assignments could include making measurements of parts of buildings, or items in and around the home, and finding perimeters, areas, and volumes in metric measurement. Finally, children will be taught to make conversions from one system to another.

These methods and materials cannot be expected to be effective unless the stages of children's learning about measures and the theory of measure, among other factors of teaching and learning, are recognized

and observed by teachers. However, the suggestions given are the results of early, concentrated efforts to provide immediate and useful ideas for meeting the impending challenge of teaching for the metric changeover. Teachers cannot afford to ignore or delay the privilege and duty of teaching today's children for tomorrow's world of metrics as Congress prepares to give the green light for conversion. Teachers must assume the obligation to prepare themselves, their pupils, and, subsequently,

the public to meet our country's commitment to go metric.

### References

- Corle, Clyde B., *Teaching Mathematics in the Elementary School*. New York: Ronald Press Co., 1964.
- De Simone, Daniel V., (a) *Education*. U.S. Metric Study, sixth substudy report. Washington, D.C.: GPO, 1971.
- (b). *A Metric America: A Decision Whose Time Has Come*. U.S. Metric Study. Washington, D.C.: GPO, 1971.

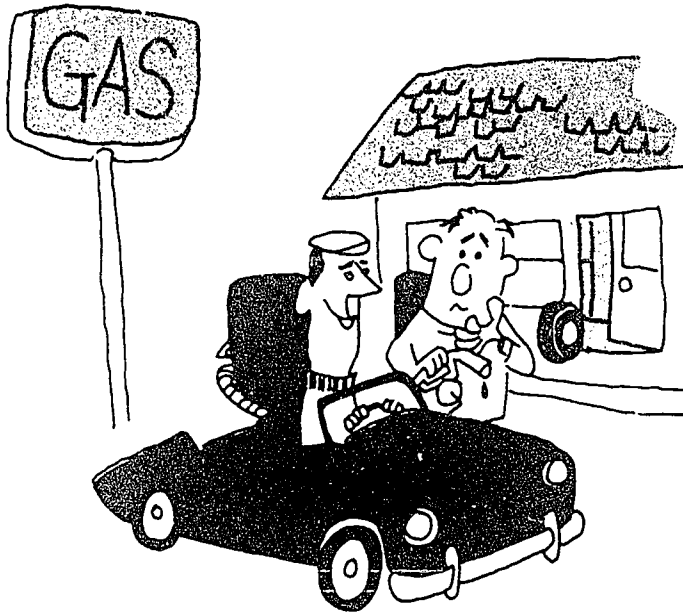

"Give me 40 liters"

# Metric equipment: how to improvise

JON L. HIGGINS

Many commercial companies are now making metric equipment for classroom use, but until a large number of industries convert to the metric system, metric measuring tools will probably be more expensive than their English counterparts. Believing that the best way for children to learn the metric system is for every child to have metric measuring tools for making measurements, teachers may face sizable purchasing problems. There is no substitute for sturdy, durable, and accurate measuring equipment, but if a school cannot afford to buy such equipment immediately for every student, there is no reason to delay teaching the metric system. Buy a few good pieces of equipment to use as standards, and then look around for substitutes that each student can use in the meantime. You may be surprised to learn that you are already living in a metric world!

## Dividing by ten

One of the basic difficulties in improvising metric equipment is the problem of dividing by ten. The problem of dividing a given unit of length into ten equal parts does not have an obvious solution to children. If one takes a strip of paper and folds it in half, in half again, and in half once again, the creases will divide the strip into halves, fourths, and eighths. (Is this why the English system was divided into eighths and sixteenths?) But how can one divide a length into tenths?

The answer lies in a nice piece of geometry that older children might enjoy. Start with a strip of paper representing a length you wish to divide into tenths. Lay the strip on a sheet of paper and draw a line from the beginning of the strip outward at an angle; any angle will do (see fig. 1).

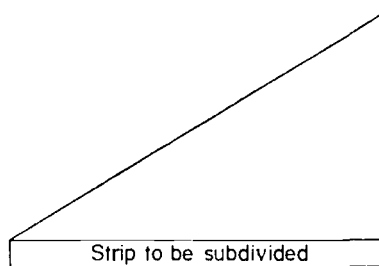

Fig. 1

Now take *any* convenient length unit, and mark ten of them off on the angled line, beginning at the vertex formed by the line and the strip. You may need to extend the line in order to mark off ten lengths, or you may not use all of the line (see fig. 2).

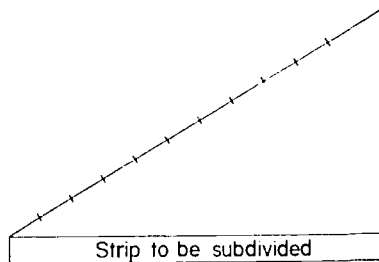

Fig. 2

Draw a line from the end of the tenth unit to the other end of the strip, as shown in figure 3. Then draw parallel lines from the ends of the other lengths. These parallels will intercept the strip, marking off ten equal lengths and thus subdividing the strip just as we want it.

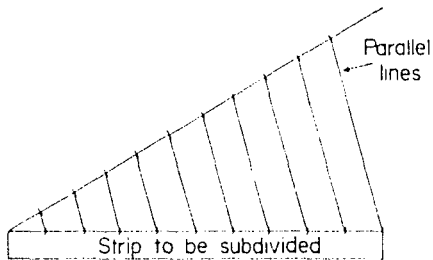

Fig. 3

Children may be able to estimate parallel lines by simply sliding a straightedge sideways. If this does not seem accurate enough, they can construct parallels with a compass and straightedge as suggested by figure 4.

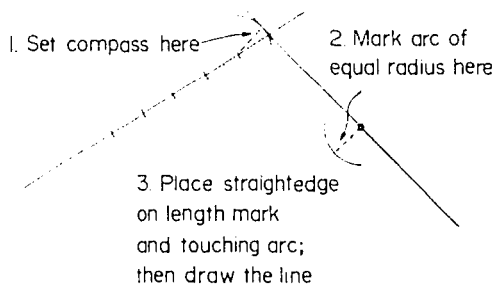

Fig. 4

For children not adept at using a compass, the following method may be somewhat easier. Perpendicular lines are extended from both ends of the segment to be subdivided. A straightedge with ten equal subdivisions is turned until its ends lie on the parallel lines, and the position of the endpoint of each subdivision is marked. (The total length of the ten arbitrary subdivisions on the straightedge must be longer than the segment to be subdivided.) Then the straightedge is slid down slightly and

the positions are marked again. Corresponding pairs of marks can be joined with lines that, when extended, will intercept the original segment, dividing it as desired. Figure 5 illustrates this procedure.

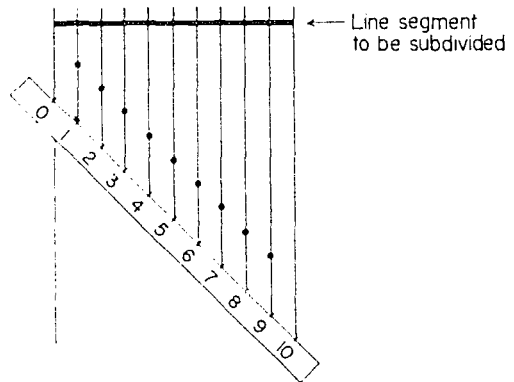

Fig. 5

### Length units

Metric measuring tapes can be made by copying metric scales on strips of adding-machine tape. You may want to make tapes that are as long as 5 or 10 meters to help children visualize longer lengths, or you might want to use the tapes for the construction exercise discussed in the previous section. Children can learn about units and subdivisions in the process of copying and making their own tapes.

Do you own a set of Cuisenaire rods? These rods are one square centimeter in cross section, and their lengths range from one to ten centimeters. The notions departments of fabric stores often carry measuring tapes that are marked in metric units. If you need smaller units, remember that a dime is one millimeter thick.

### Area units and volume units

Look for graph paper ruled in squares that are 2 millimeters on each side. Rule a piece of paper into grids of one square centimeter. You may have a machine in your school office that will make transparencies for overhead projectors; if so, make several transparencies using your ruled paper. These plastic sheets can be

laid over objects and the squares counted to estimate areas in square centimeters.

Building boxes in metric units to illustrate metric volumes is a good exercise in geometry as well as metric measurement. Figure 6 illustrates some different patterns for building boxes. How many others can your students think of?

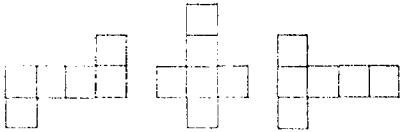

Fig. 6

### Weighing and weight units

Because the gram is a very light unit of weight, many older balances are not sensitive enough to be used successfully with metric weights. Fortunately, it is fairly easy to build an inexpensive balance that is easy to use. The main components of the balance are shown in Figure 7. The heart

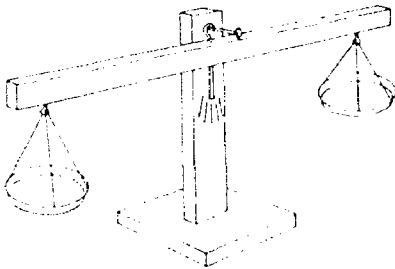

Fig. 7

of the balance is a wooden stick, about 40 cm long. Three cup hooks are screwed into the stick, one in the middle on one side of the stick, and one at each end on the other side of the stick. A small nail is driven into the stick opposite the middle cup hook to serve as an indicator. Weighing pans made from small pie tins are hung from the cup hooks at the ends of the balance (tins from frozen pot pies work well for this). The entire balance is hung on the center cup hook. A nail on a

wall, a string from the ceiling, or a wooden upright stand will all make suitable supports for hanging the balance.

To use the balance, hang it from its support. You will need to adjust it so that the stick is horizontal when the pans are empty. One easy way to do this is to fasten small nails or paper clips with tape to the light end of the stick. When the empty balance is adjusted, mark the position of the indicator nail below the center cup hook. When weighing objects, put the object in one pan and add metric weights to the other pan until the indicator nail returns to the marked position.

Sets of weights can be made by beginning with nickels. A nickel weighs five grams. Paper clips are inexpensive and uniform weights; however, sizes of paper clips vary from brand to brand, so their weight should always be checked against the five-gram nickel. Cubes of sugar weigh approximately two grams and can be used for weights, if you don't mind losing a few to nibblers!

For larger weights, check your pantry at home. Many cans of soups and vegetables are now marked in both ounces and grams. Metric weights are usually found in small print on the sides of can labels or the small side panels of boxes. A quick trip to one pantry turned up a 305-gram can of chicken noodle soup, a 425-gram can of beans, and a 907-gram box of pancake mix.

### Temperature units

Thermometers may be recalibrated to the Celsius temperature scale. Put the thermometer in a pan of ice and water, and mark the lowest point that the mercury reaches. (Dip only the bulb of the thermometer in the water; if the stem is dry you can mark the level of the mercury with a grease pencil or a small piece of tape.)

Now place the bulb of the thermometer in a pan of boiling water and mark the highest level the mercury reaches. The two marked points are the 0 (freezing) and

100 (boiling) points on the Celsius scale. Lay the dry thermometer on a piece of paper and copy the two marks. The distance between these marks must now be subdivided into 100 equal pieces. This task is one of subdividing lengths, and the geometrical procedure discussed earlier can now be used.

### **Accuracy**

Making your own Celsius thermometer sacrifices the accuracy in favor of low cost. The temperature of the ice and water mixture may not be exactly the temperature at which water freezes, and the temperature of the boiling water depends on the air pressure of the room. However,

you may find that you gain new attitudes toward measurements and measuring instruments when you make or adapt them yourself. The mystery of a thermometer scale tends to disappear when it is treated as a special length scale.

In a similar fashion, constructing weight units out of familiar everyday objects may make the weighing process seem much more practical than if one relied exclusively on brightly polished brass weights. Constructing units of length, area, and volume quickly imparts the idea that the metric system is a constructed system. In the end, you may discover that saving money is the least important reason for improvising metric equipment.



# Think metric—live metric

RICHARD J. SHUMWAY, LARRY A. SACHS,  
and JON L. HIGGINS

Suppose we accept the premise that we should learn the metric system. What kinds of knowledge would be needed? How could one best acquire such knowledge? One place to begin is by looking at yourself. Try your hand at the following sample test items. Can you make reasonable estimates or guesses?

- The height of a man playing center on a typical high school basketball team is approximately
  - 6 m
  - 240 m
  - 2 m
  - 78 cm
- My car was a little low on oil so the gas station attendant recommended that I add a can of oil containing
  - 2 ml
  - 1 l
  - 10 ml
  - 20 l
- The diameter of a coffee cup is about
  - 1 cm
  - 8 cm
  - 20 cm
  - 50 cm
- In order to bake a pizza, one should set the oven temperature at about
  - 100 C
  - 400 °C
  - 220 C
  - 600 C
- A good weight for a college-age girl of average height would be about
  - 130 gm
  - 40 gm
  - 150 kg
  - 55 kg
- The length of a car is approximately
  - 5 m
  - 15 mm
  - 26 m
  - 3 cm
- The capacity of a classroom aquarium is usually about
  - 10 l
  - 200 ml
  - 40 l
  - 25 ml
- A good temperature to set your home thermostat at for comfortable living would be
  - 90 C
  - 32 C
  - 70 °C
  - 20 C

(Answers for these items can be found at the end of the article.)

Living metric will certainly require everyday knowledge of the type reflected in these test items. It probably will not require extensive ability to compute unit conversions accurate to three decimal places. Decisions will need to be made more

rapidly than the time required for computing equivalents; however, most everyday decisions do not require a high degree of precision. Thus, except for a very few technical jobs, living metric will require familiarity with the system so that reasonable estimates can be made.

How can you acquire this familiarity? We propose that you go "cold turkey." That is, don't even think metric, just live metric. Two rules are important: (1) all measure must be metric, and (2) you must "get your hands dirty;" i.e., you must be willing to measure in order to learn measure.

To quote an old adage, education begins in the home. Start with your thermometer. Make ten labels that you can stick over the scale of your thermometer, one label with each of the following numbers: -40, -30, -20, -10, 0, 10, 20, 30, 40, 50. Table 1 shows over which number to put each label.

**Table 1**  
**Temperature conversion**

<i>Celsius</i>	<i>Fahrenheit</i>
-40	-40.0
-30	-22.0
-20	-4.0
-10	14.0
0	32.0
10	50.0
20	68.0
30	86.0
40	104.0
50	122.0

Here is the computer program used to generate the table:

```

10 FOR C = -40 TO 50 STEP 10
20 LET F = 9*C/5+32
30 PRINT USING 40, C,F
40 IMAGE
-----
50 NEXT C

```

For example, the 0 should be pasted over the 32 mark on the Fahrenheit scale, the 10 over the 50 mark, and so on. Be sure you cover up the old numbers completely so that you can't see the tempera-

ture in Fahrenheit. Now take a thin strip of paper and cover up the subdivision marks from the old scale. You can estimate the appropriate subdivisions between the new Celsius numbers.

You may be uncomfortable about reading temperatures in Celsius degrees at first, but if you make yourself live metric, you will soon feel just as comfortable with numbers like 10, 20, and 30 as you used to feel with numbers like 50, 70, and 90. You have to be ruthless, though, and cover all the old Fahrenheit scales so that you force yourself to live metric.

Now to the bathroom scale. Make twenty labels for the numbers 5, 10, 15, 20, . . . 90, 95, 100. Peel back the material around the window of your scale so that the window may be removed (see fig. 1).

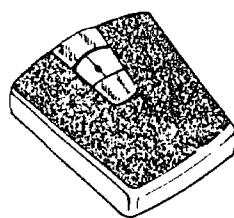

Fig. 1

Then, using table 2, paste the labels over the appropriate numbers.

**Table 2**  
**Weight conversion—bathroom scale**

<i>kg</i>	<i>lbs</i>	<i>kg</i>	<i>lbs</i>
5	11	65	143
10	22	70	154
15	33	75	165
20	44	80	176
25	55	85	187
30	66	90	198
35	77	95	209
40	88	100	220
45	99	105	231
50	110	110	243
55	121	115	254
60	132		

For example, the 5 would be pasted on the scale at 11, the 10 at 22, the 15 at 33,

and so on. Again, give yourself no sympathy. Cover up the old numbers and the old subdivision marks completely. Don't use table 2 to convert back to pounds again—put it away! Once your scale is labeled, you no longer need table 2. The best way to get used to kilograms is to have to use kilograms.

Now relabel those old yardsticks! Paste new numbers at the positions shown in table 3.

**Table 3**  
**Length conversions**

<i>in</i>	<i>cm</i>
4	10
8	20
11 7 8	30
15 3 4	40
19 5 8	50
23 5 8	60
27 1 2	70
31 1 2	80
35 3 8	90

Cover all the old numbers and scale divisions. Estimate the subdivisions between the new centimeter numbers.

You may prefer to destroy your old yardsticks and make new meter tapes. Two meters is an ideal length for many purposes, and buckram (available at most fabric stores) is a near-perfect, yet inexpensive, material. Buckram usually comes in three-inch widths (fabric stores haven't completed their metric changeover) that can easily be torn lengthwise into strips. Make three strips, each about 2.5 cm wide. Cut them into two-meter lengths. Using a meter stick and a felt-tip marker, dimension and label your tape measure with divisions and numerals as are desirable and practical. (A scale of centimeters is usually fine, with possibly some millimeters shown at the beginning.)

Again, remember that the point of living metric is to make a *complete* change. Change *all* your yardsticks, or destroy them, or lock them away forever! You'll find that forcing yourself to live metric

will eventually make thinking metric a very natural thing to do.

There are many other changes you can make in your home. Use the information in table 4 to begin labeling other things in your home. Be a little goofy about it. You can make it fun!

Don't forget to relabel the tools you use for your hobbies. Sewing, woodworking, photography, travel, and so on, are all ideal vehicles for learning to live metric because the sizes of things are familiar to you.

### Living metric in the classroom

When you have relabeled your home, start relabeling your classroom and school. You may want to accelerate the pace at which the metric system is used by creating special measuring activities. Use the new meter stick or tape measure to become familiar with some common lengths in metric. Are you 1.6 m tall with a waist of 60 cm? Is your pencil 11.5 cm long and your notebook paper 22 cm wide? As you become more comfortable with metric lengths, estimate before you actually measure. You may be surprised at how quickly the accuracy of your estimates improves.

Do you have a juice or Kool-Aid break in your class? Turn it into an experience with metric volumes. Let the children order the amount they want in metric measures. An order for ten milliliters receives less than a tablespoon full; a request for two liters gets a half-gallon pitcher full!

Besides requiring children to practice their metric knowledge and adding a little humor, this is an excellent opportunity to emphasize the volume/mass relationship. Try using styrofoam cups that have a very small mass (less than 5 g). If a child requested 150 ml, how could you check how accurate the dispenser of the juice was with his estimate? If you were thinking "weigh the juice and cup," you're right! Since juice is mostly water and one milliliter of water at 4 degrees Celsius weighs one gram, the weight of the juice in grams

is a good approximation of its volume in milliliters.

After you have introduced a series of individual activities for practicing metric skills, it's interesting to get the class together for a metric countdown. Prior to its start, each child should have measured and labeled several items for use in the countdown. Divide the class into two teams and proceed as in a spelling bee, where the object is to guess the metric measurements of different items. Two modifications

make for a better game. First, accept "ball park" answers as correct. If one player guesses the width of a desk to be 80 cm when it is actually 88 cm, for example, he should certainly be given credit. A guess of 50 cm, though, is probably not close enough. One person can act as judge, basing his decisions on the ability level of the group. Second, if one person on each team misses an item, it is best to announce the correct measurement and go on to the next item.

**Table 4**  
**Other metric conversions**

<i>Distances to Places You Travel</i>		<i>Kitchen Scale</i>		<i>Room Dimensions</i>		
5 km	3 mi	100 gm	3.5 oz	0.22 lb	1.0 m	3.3 ft
10 km	6 mi	200 gm	7.1 oz	0.44 lb	1.5 m	4.9 ft
15 km	9 mi	300 gm	10.6 oz	0.66 lb	2.0 m	6.6 ft
20 km	12 mi	400 gm	14.1 oz	0.88 lb	2.5 m	8.2 ft
25 km	16 mi	500 gm	17.6 oz	1.10 lb	3.0 m	9.8 ft
30 km	19 mi	600 gm	21.2 oz	1.32 lb	3.5 m	11.5 ft
35 km	22 mi	700 gm	24.7 oz	1.54 lb	4.0 m	13.1 ft
40 km	25 mi	800 gm	28.2 oz	1.76 lb	4.5 m	14.8 ft
45 km	28 mi	900 gm	31.7 oz	1.98 lb	5.0 m	16.4 ft
50 km	31 mi	1000 gm	35.3 oz	2.20 lb	5.5 m	18.0 ft
100 km	62 mi	1100 gm	38.8 oz	2.43 lb	6.0 m	19.7 ft
150 km	93 mi	1200 gm	42.3 oz	2.65 lb	6.5 m	21.3 ft
200 km	124 mi	1300 gm	45.9 oz	2.87 lb	7.0 m	23.0 ft
250 km	155 mi	1400 gm	49.4 oz	3.09 lb	7.5 m	24.6 ft
300 km	186 mi	1500 gm	52.9 oz	3.31 lb	8.0 m	26.2 ft
350 km	217 mi	1600 gm	56.4 oz	3.53 lb	8.5 m	27.9 ft
400 km	249 mi	1700 gm	60.0 oz	3.75 lb	9.0 m	29.5 ft
450 km	280 mi	1800 gm	63.5 oz	3.97 lb	9.5 m	31.2 ft
500 km	311 mi	1900 gm	67.0 oz	4.19 lb	10.0 m	32.8 ft
1000 km	621 mi	2000 gm	70.5 oz	4.41 lb	10.5 m	34.4 ft
1500 km	932 mi				11.0 m	36.1 ft
2000 km	1243 mi					
2500 km	1553 mi					
3000 km	1864 mi					
3500 km	2175 mi					
4000 km	2485 mi					
<i>Speedometer</i>		<i>Kitchen Capacities</i>		<i>Scrub Pail</i>		
20 km/hr	12 mi/hr	2.5 ml	1/2 teaspoon	1 1	1.1 qts	
40 km/hr	25 mi/hr	5 ml	1 teaspoon	2 1	2.1 qts	
60 km/hr	37 mi/hr	15 ml	1 tablespoon	3 1	3.2 qts	
80 km/hr	50 mi/hr	60 ml	1/4 cup	4 1	4.2 qts	
100 km/hr	62 mi/hr	80 ml	1/3 cup	5 1	5.3 qts	
120 km/hr	75 mi/hr	120 ml	1/2 cup	6 1	6.3 qts	
140 km/hr	87 mi/hr	160 ml	2/3 cup	7 1	7.4 qts	
		180 ml	3/4 cup	8 1	8.5 qts	
		240 ml	1 cup	9 1	9.5 qts	
				10 1	10.6 qts	
		<i>Drinking Glass and Pitcher</i>		<i>Gas Tank</i>		
		100 ml	3.4 fl oz	10 l	2.6 gal	
		200 ml	6.8 fl oz	20 l	5.3 gal	
		300 ml	10.1 fl oz	30 l	7.9 gal	
		400 ml	13.5 fl oz	40 l	10.6 gal	
		500 ml	16.9 fl oz	50 l	13.2 gal	
		600 ml	20.3 fl oz	60 l	15.9 gal	
		700 ml	23.7 fl oz	70 l	18.5 gal	
		800 ml	27.1 fl oz	80 l	21.1 gal	
		900 ml	30.4 fl oz	90 l	23.8 gal	
		1000 ml	33.8 fl oz	100 l	26.4 gal	
<i>Oven Temperature</i>						
100°C	212°F					
125°C	257°F					
150°C	302°F					
175°C	347°F					
200°C	392°F					
225°C	437°F					
270°C	482°F					

The list of activities and games that will encourage children to live metric is endless. Once you have converted your house and classroom to the metric system, get out your plan book and convert your own time-tested classroom activities to

metric. Once you do, you'll find that thinking metric and living metric is not only easy, but enjoyable!

Oh, yes, the answers to the sample test items are 1, *c*; 2, *b*; 3, *b*; 4, *c*; 5, *d*; 6, *a*; 7, *c*; 8, *d*.

# Procedures for designing your own metric games for pupil involvement

CECIL R. TRUEBLOOD and  
MICHAEL SZABO

*Currently an associate professor in mathematics education at Pennsylvania State University, Cecil Trueblood is particularly interested in the teaching of mathematics in the elementary school. Michael Szabo, also at Pennsylvania State, is an associate professor of science education. His educational interests center on instructional development, individualized instruction, and complex problem-solving.*

Although much has been written on the values of mathematical games in the elementary grades and many game books have been published, little has been written that would help classroom teachers design, produce, and evaluate games for use in their classroom. The focus of this article is to present a set of seven criteria that were developed in a summer workshop for inservice elementary teachers who decided that they wanted to be able to produce metric games and related activities that would fit into their "metrication" program.

The teachers in the workshop began by asking a practical question: Why should I be interested in producing my own metric games? They concluded that the game format provided them with specific activities for pupils who did not respond to the more typical patterns of instruction. They felt that in the game format they could provide activities of a higher cognitive level for pupils who had difficulty responding to material requiring advanced reading skills.

The teachers then asked a second question: Does the literature on the use of mathematics games contain any evidence that would encourage busy classroom teachers to use planning time to develop

their own games? The available professional opinion supported the following conclusions:

1. Games can be used with modest success with verbally unskilled and emotionally disturbed students, and students for whom English is a second language.
2. Games have helped some teachers deal with students who present discipline problems because they are bored with the regular classroom routine.
3. Games seem to fit well into classrooms where the laboratory or learning-center approach is used. This seems related to the feature that games can be operated independent of direct teacher control thus freeing the teacher to observe and provide individual pupils with assistance on the same or related content.

## Plan for development

If for any of the reasons just cited you are interested in designing and evaluating several of your own metric games, how should you begin? Simply use the following checklist as a step-by-step guide to help you generate the materials needed to create your game. Use the exemplar that follows the checklist as a source for more detailed

suggestions. Each item in the checklist has been keyed to the exemplar to facilitate cross referencing.

### CHECKLIST GUIDE

- Write down what you want your students to learn from playing your game. (Establish specific outcomes)
- Develop the materials required to play the game. (Make simple materials)
- Develop the rules and procedures needed to tell each player how to participate in the game. (Write simple rules and procedures)
- Decide how you want students to obtain knowledge of results. (Provide immediate feedback)
- Create some way for chance to enter into the playing of the game. (Build in some suspense)
- Pick out the features that can be easily changed to vary the focus or rules of the game. (Create the materials to allow variation)
- Find out what the students think of the game and decide whether they learned what you intended them to learn. (Evaluate the game)

#### The exemplar

##### *Establish specific outcomes*

By carefully choosing objectives that involve both mathematics and science processes—such as observing, measuring, and classifying—the teachers created a game that involves players in the integrated activities. This approach reinforces the philosophy that science and mathematics can be taught together when the activities are mutually beneficial. That is, in many instances integrated activities can be used to conserve instructional time and to promote the transfer of process skills from one subject area to the other. The exemplar's objectives are labeled to show their relationship to science and mathematical processes.

1. Given a set of common objects, the students estimate the objects' weight correct to the nearest kilogram. (Observation and estimation)

2. Given an equal-arm balance, the students weigh and record the weights of common objects correct to the nearest centigram. (Measurement)

3. Given an object's estimated and observed weight correct to the nearest centigram, the student computes the amount over or under his estimate. (Computation and number relationships)

##### *Make simple materials*

The following materials were constructed or assembled to help students attain the objectives previously stated in an interesting and challenging manner.

1. Sets of 3-by-5 cards with tasks given on the front and correct answers and points to be scored on the back. (See fig. 1.)

2. A cardboard track (see fig. 2) made from oak tag. Shuffle the *E*'s (estimate cards), *O*'s (observed cards), and the *D*'s (difference cards) and place them on the gameboard in the places indicated.

3. An equal-arm balance that can weigh objects up to 7 kilograms.

4. A pair of dice and one different colored button per player.

5. A set of common objects that weigh less than 7 kilograms and more than 1 kilogram.

6. Student record card. (See fig. 3.)

##### *Write simple rules and procedures*

The rules and procedures are crucial to making a game self-instructional. In the following set of directions notice how a student leader and an answer card deck serve to ease the answer processing needed to keep the game moving smoothly from one player to another. It is essential to keep the rules simple and straightforward so that play moves quickly from one student to the other.

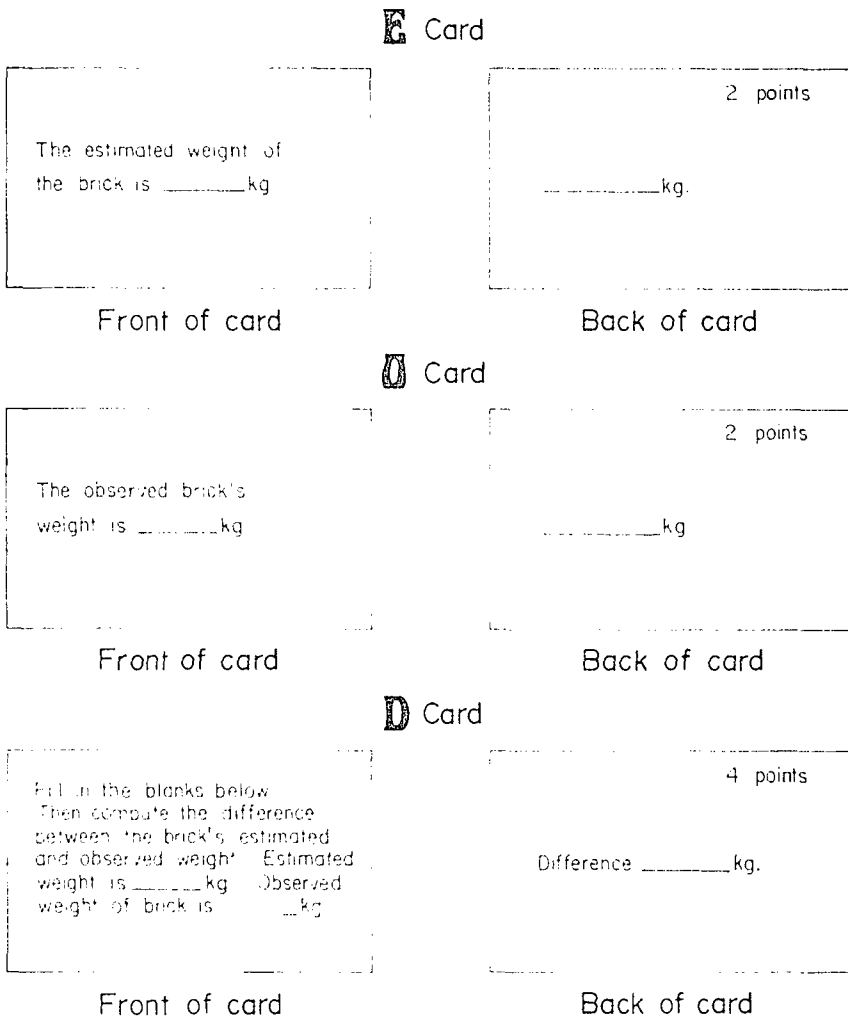

Fig. 1

1. Number of players, two to six.
2. The student leader or teacher aide begins by rolling the dice.

The highest roll goes first. All players start with their buttons in the "Start Here" block. The first player rolls one die and moves his button the number of spaces indicated on the die. If he lands on a space containing an *E*, *O*, or *D* he must choose the top card in the appropriate deck located in the center of the playing board or track and perform the task indicated. (In the example shown in figure 1 this would be Card *E*<sub>3</sub>.)

The player then records the card number, his answer, and the points awarded by the student leader on his record card. The student leader checks each player's answer and awards the appropriate number of points by reading the back side on the task card. He then places that card on the bottom of the appropriate deck and play moves to the right of the first player. The player who reaches "Home" square with the highest number of points is the winner. At the end of the play each player turns in his score card to the student leader who gives them to the teacher.



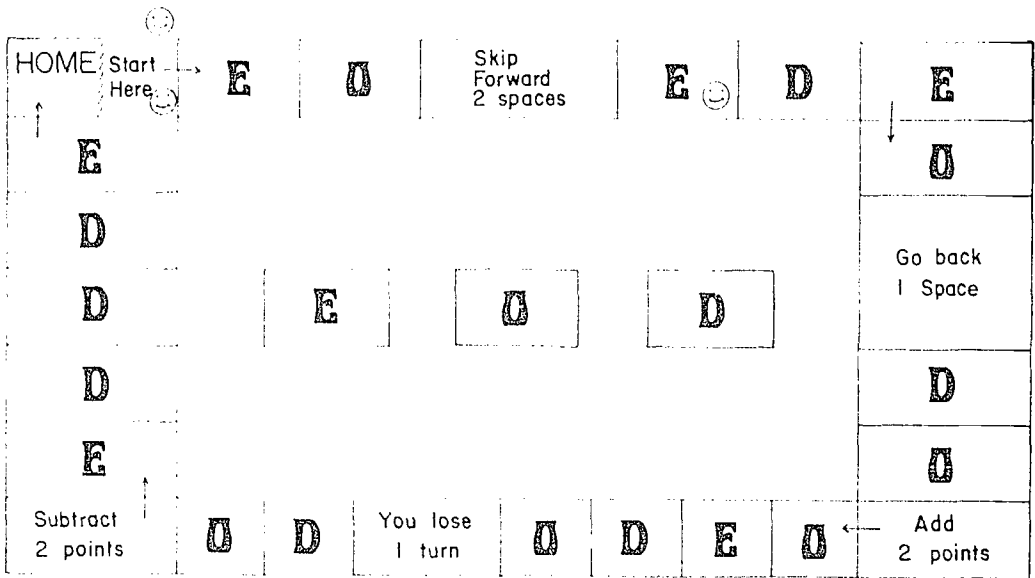

Fig. 2

### *Provide immediate feedback*

By placing the answer on the back of the task card and appointing a student leader, the teacher who developed this game built into the game an important characteristic, immediate knowledge of the results of each player's performance. In most cases this feedback feature can be built into a game—by using the back of task cards, by creating an answer deck, or by using a student leader whose level of performance would permit him to judge the adequacy of other students' performance in a reliable manner. Feedback is one of the key features of an instructional game because it has motivational as well as instructional impact.

*Have students record diagnostic information.* The student record card is an important feature of the game. The cards help the teacher to judge when the difficulty of the task card should be altered and which players should play together in a game, and to designate student leaders for succeeding games. The card also provides the player with a record that shows his scores and motivates him to improve.

This evaluative feature can be built into most games by using an individual record card, by having the student leader pile cards yielding right answers in one pile and cards with wrong answers in another pile, or by having the student leader record the results of each play on a class record sheet.

### *Build in some suspense*

Experience has shown that games enjoyed by students contain some element of risk or chance. In this particular game a player gets a task card based upon the roll of the die. He also has the possibility of being skipped forward or skipped back spaces, or of losing his turn. Skipping back builds in the possibility of getting additional opportunities to score points; this feature helps low-scoring students catch up. Skipping forward cuts the number of opportunities a high-scoring player has to accumulate points. The possibility of adding or subtracting points also helps create some suspense. These suspense-creating features help make the game what the students call "a fun game."

Student's name _____		Date _____
Card number	Answer given	Number of points
E <sub>3</sub>	2 kg.	2
E <sub>2</sub>	1 kg.	1

Fig. 3

### Create the materials to allow variation

A game that has the potential for variation with minor modifications of the rules or materials has at least two advantages. First, it allows a new game to be created without a large time investment on the part of the teacher. Second, it keeps the game from becoming stale because the students know all the answers. For instance, the exemplar game can be quickly changed by making new task cards that require that students estimate and measure the area of common surfaces found in the classroom such as a desk or table tops. By combining the two decks mixed practice could be provided.

### Evaluate the game

Try the game and variations with a small group of students and observe their actions. Use the first-round record cards as a pretest. Keep the succeeding record cards for each student in correct order. By comparing the last-round record cards with the first-round record cards for a specific student, you can keep track of the progress a particular student is making. Filing the cards by student names will provide a longitudinal record of a student's progress for a given skill as well as diagnostic information for future instruction.

Finally, decide whether the students enjoy the game. The best way is to use a self-report form containing several single questions like the following, which can be answered in an interview or in writing:

1. Would you recommend the game to someone else in the class? \_\_\_Yes \_\_\_No

2. Which face indicates how you felt when you were playing the game?



3. What part of the game did you like best?

4. How would you improve the game?

### Concluding remarks

The procedure just illustrated can be generalized to other topics in science and mathematics. The following list provides some suggested topics.

1. Classifying objects measured in metric units by weight and shape
2. Measuring volume and weight with metric instruments
3. Measuring length and area with metric instruments
4. Classifying objects measured in metric units by size and shape
5. Comparing the weight of a liquid to its volume
6. Comparing the weight of a liquid with the weight of an equal volume of water
7. Predicting what will happen to a block on an inclined plane
8. Comparing the weights of different metals of equal volume

Why don't you try and create some games for each of these topics? Then share the results with your colleagues. Additional examples developed by the authors are available in "Metric Games and Bulletin Boards" in *The Instructor Handbook Series* No. 319 (Dansville, New York, 1973).

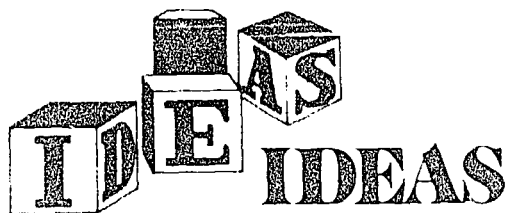

Activities that contribute to the student's personal understanding of key concepts in mathematics.

Prepared by **George Immerzeel and Don Wiederanders**, Malcolm Price Laboratory School, University of Northern Iowa, Cedar Falls, Iowa.

*Each IDEAS presents activities that are appropriate for use with students at the various levels in the elementary school. After you have chosen the activities that are most appropriate for your students, remove the activity sheets and reproduce the copies you need. After a sheet has been used, add your own comments and file the materials for future use.*

*IDEAS for this month relates to units of measure. The focus is on the metric system. Activities at the lower levels use the familiar number line to relate basic units of measure within the metric system. Upper level activities use the number line to relate familiar English units and basic metric units.*



For Teachers

Objective: Experience in relating basic units of linear measure using a metric number line

Levels: 1, 2, or 3

Directions for teachers:

1. Remove the activity sheet. Reproduce a copy for each student.
2. Have a student measure with a meter stick the width or height of a familiar object in the front of the room. Have everyone put his pencil on his metric number line to show the measure reported by the student.
3. Be sure your students understand the directions for each part before they proceed.

*Comments:* Metric measures are likely to be more important to your students' lives than English measures. It is the school's responsibility to provide learning situations in which the student relates personally to metric units of measure. If your students have not had experiences in actual measurement with centimeter scales prior to this time, such experiences should precede the use of this activity sheet.

Put an X on the metric line for each of these measures.

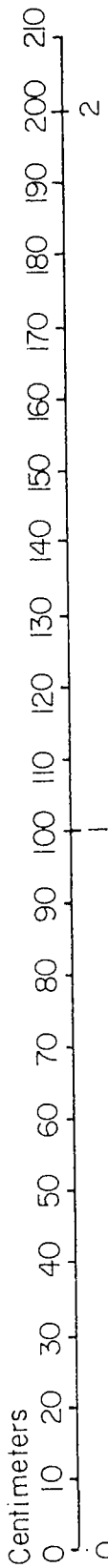

Meters

10 centimeters

30 centimeters

35 centimeters

1 meter

1 meter 10 centimeters

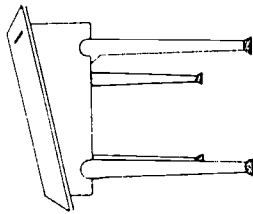
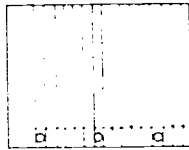
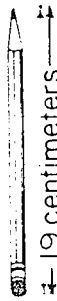

Name each of these points on the metric line.

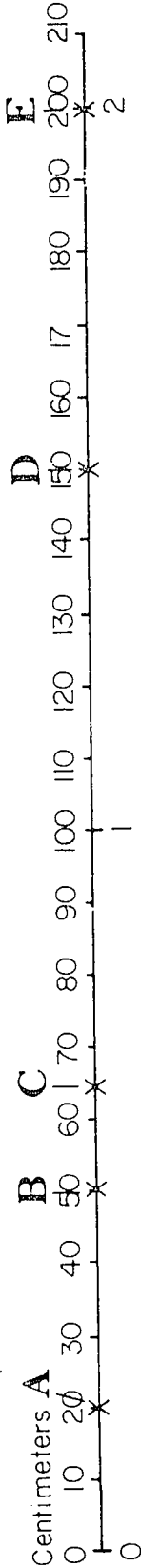

Meters

A \_\_\_\_\_ centimeters

C \_\_\_\_\_ centimeters

E \_\_\_\_\_ centimeters

B \_\_\_\_\_ centimeters

D \_\_\_\_\_ centimeters

E \_\_\_\_\_ meters



For Teachers

Objectives: Experience in relating basic metric units of weight using a number line model

Levels: 2 or 3

Directions for teachers:

1. Remove the activity sheet and reproduce a copy for each student.
2. Hold up some familiar objects such as a chalkboard eraser labeled 52 grams and a book labeled 525 grams. Have each student use his pencil to show each weight on his metric number line.
3. Have students do the first set of exercises on the activity sheet. Note that the abbreviation for grams is used on the drawings.
4. Ask if any of the weights shown could have other names (1000 grams = 1 kilogram and 2000 grams = 2 kilograms).
5. Have students do the remaining exercises. The second set of exercises helps to focus on the two names for special points on the metric line.

*Comments:* These activities are not meant to replace experiences that build the student's basic referent for units of metric weight. Prior to using this activity sheet, the student should have personal experience in weighing familiar objects using metric scales.

t-7



Where are you?

# I D E A S

Name \_\_\_\_\_

Put an X on the line for each metric weight.

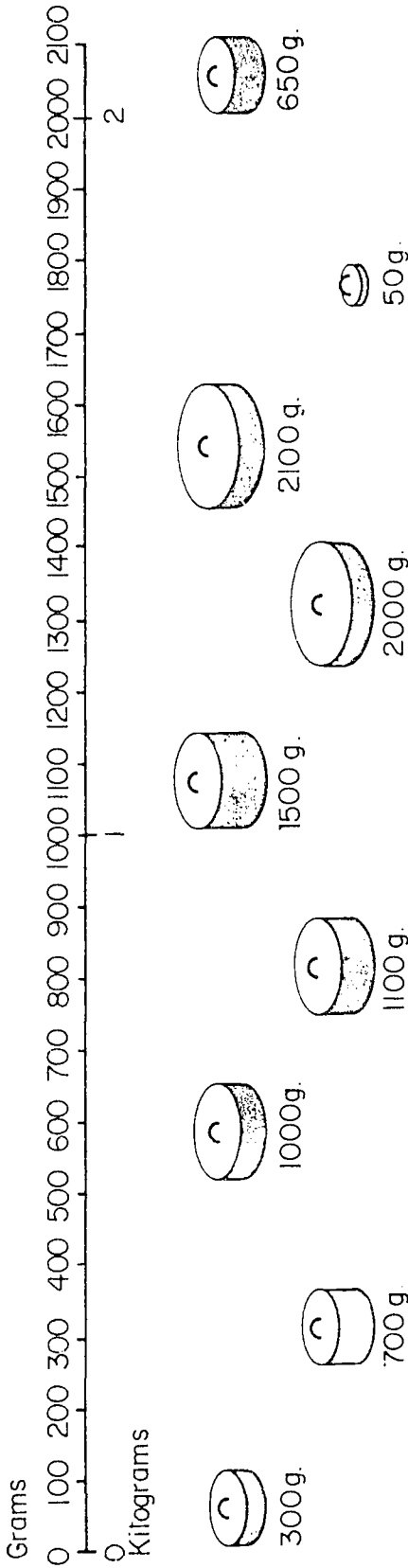

Name each of these points.

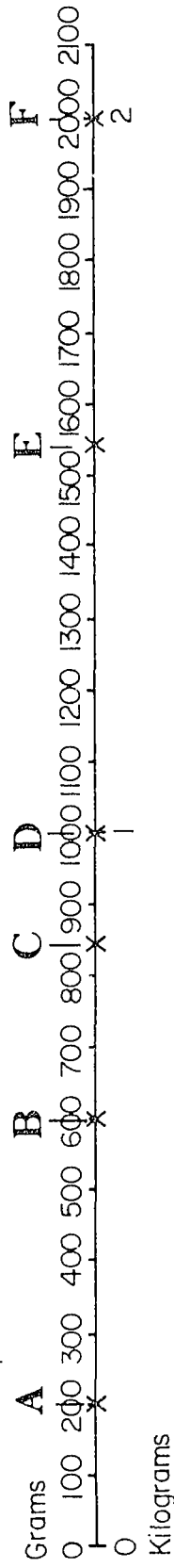

**A** \_\_\_\_\_ grams      **B** \_\_\_\_\_ grams      **C** \_\_\_\_\_ grams      **D** \_\_\_\_\_ kilograms      **E** \_\_\_\_\_ grams

**F** \_\_\_\_\_ grams      **D** \_\_\_\_\_ grams      **F** \_\_\_\_\_ kilograms

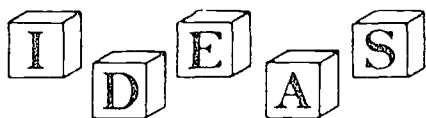

For Teachers

Objective: Experience with the metric system of weight

Grade level: 1, 2, or 3

Directions for teachers:

Remove the student activity sheet and reproduce a copy for each student. If feasible, each student should be given a sugar cube as a referent. Under less ideal circumstances, you may exhibit one or more sugar cubes to be sure that each student has at least a visual image of the object that weighs "2 grams."

Directions for students:

1. Note that each stack is made of sugar cubes and that each sugar cube weighs 2 grams.
2. Decide how much each stack weighs.

*Comments:* For sanitary and health reasons, it is impractical to have each student personally build and feel the weight of each stack of sugar cubes. This experience may easily be converted to a hands-on laboratory experience by using one-inch cubes that weigh approximately ten grams each. In classrooms where the students have had previous experiences with three-dimensional geometry, a work table with a box of wooden cubes will suffice as an aid for those students who can't visualize the stacks as pictured. Expect students to attack these problems in a variety of ways. Some will count by twos; others will find the number of cubes and multiply that number by two. Some students may solve *G* by simply multiplying the answer to *D* by five.

*Answers*

A. 6   B. 8   C. 16   D. 12   E. 12   F. 20   G. 60

I D E A S

Name \_\_\_\_\_

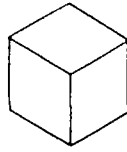

2 grams

Sugar Cube

How much does each stack weigh ?

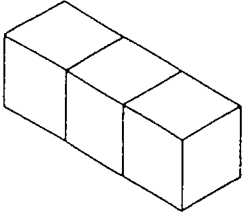

A. \_\_\_\_\_ grams

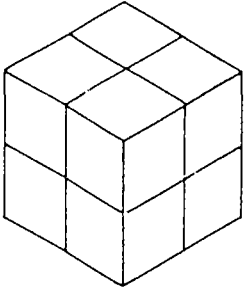

C. \_\_\_\_\_ grams

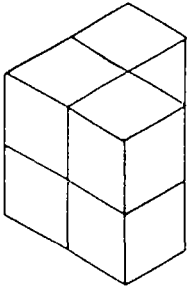

E. \_\_\_\_\_ grams

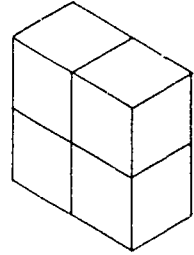

B. \_\_\_\_\_ grams

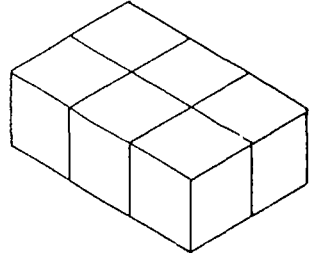

D. \_\_\_\_\_ grams

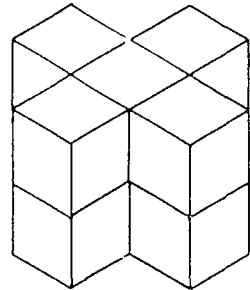

F. \_\_\_\_\_ grams

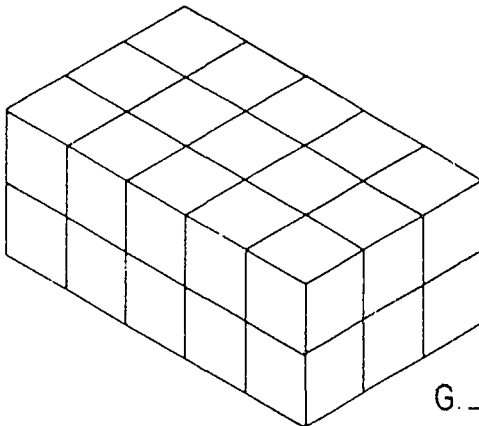

G. \_\_\_\_\_ grams





For Teachers

Objective: Experience with weight and length using the metric system

Grade level: 3 or 4

Directions for teachers:

Reproduce a copy of the activity sheet for each student. You may wish to exhibit or even pass around several new pieces of chalk. Students may note that most pieces of chalk are not identical and correctly conclude that the 8 centimeters and 10 grams are approximations. Once the students have the basic referent in mind they should work independently on this activity.

*Comments:* The total length as an end-to-end chain of individual pieces is an important concept. It should not be expected that this concept is intuitive for all students.

*Answers*

1. 20 grams, 16 centimeters
2. 5 grams, 4 centimeters
3. 15 grams, 12 centimeters
4. 25 grams, 20 centimeters

I

D

E

A

S

Name \_\_\_\_\_



Length: 8 centimeters  
Weight: 10 grams

Estimate the total weight and the total length of the pieces of chalk shown for each exercise.

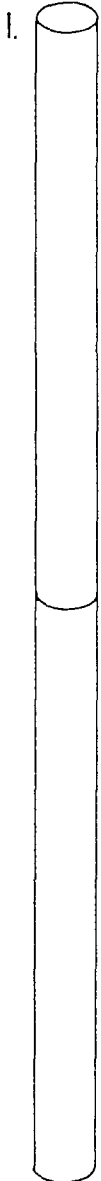

Weight: \_\_\_\_\_ grams  
Length: \_\_\_\_\_ centimeters

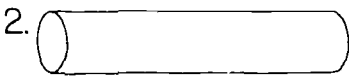

Weight: \_\_\_\_\_ grams  
Length: \_\_\_\_\_ centimeters

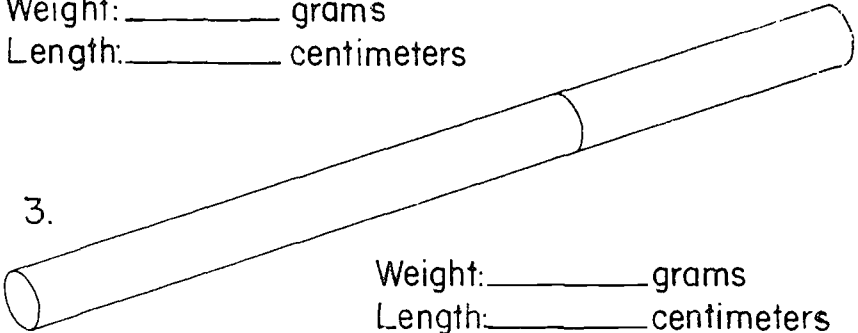

Weight: \_\_\_\_\_ grams  
Length: \_\_\_\_\_ centimeters

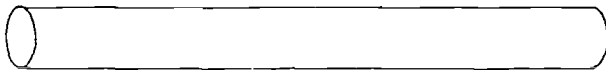
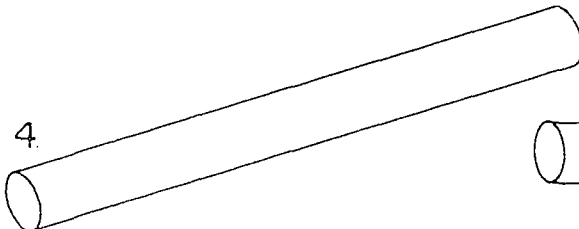

Weight: \_\_\_\_\_ grams      Length: \_\_\_\_\_ centimeters

# I D E A S

For Teachers

Objective: Experience with equivalent English and metric measures

Levels: 4, 5, 6, 7, or 8

Directions for teachers:

1. Remove the activity sheets that you feel are appropriate for your students. Make copies for each student.
2. Use one or more of these activity sheets in a measurement sequence. Note that the names of some units are abbreviated in the drawings on these sheets.
3. If students disagree regarding certain answers, they should be encouraged to perform a physical measurement to determine the correct answer.

*Comments:* These activities are not meant to replace the laboratory experiences that build the student's basic referent for measurement and the various units involved. Their use should follow laboratory experiences that include actual measuring of length, weight, and volume using instruments that measure in metric units. Contemporary science programs include the necessary measuring instruments calibrated in metric units. If the instruments are not available in your school, contact your science supervisor.

1:27



" The fever is gone. Your temperature  
is right at 37°"

# IDEAS

Name \_\_\_\_\_

## Metric

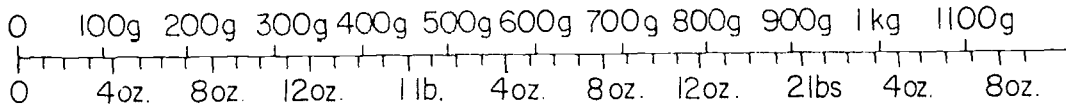

## English

Put an X on the measurement line for each measure.

8 ounces

9 ounces

$\frac{1}{2}$  pound

1 pound 2 ounces

$1\frac{1}{4}$  pound

2.2 pounds

40 grams

100 grams

500 grams

10 grams

1000 grams

1050 grams

Estimate the weight in grams of each object.

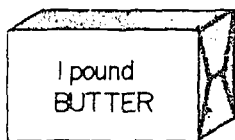

\_\_\_\_\_ grams

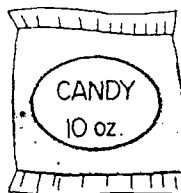

\_\_\_\_\_ grams

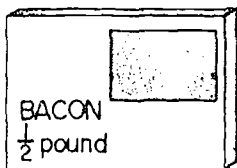

\_\_\_\_\_ grams



\_\_\_\_\_ grams

# I D E A S

Name \_\_\_\_\_

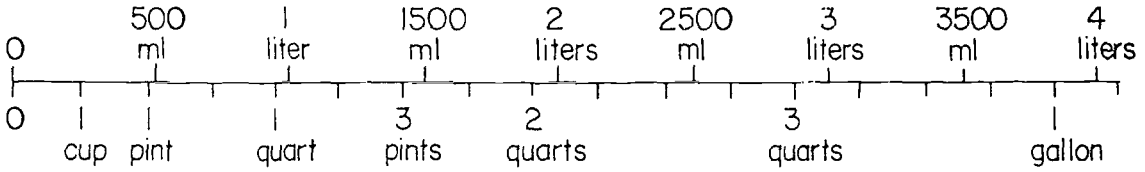

Put an X on the measurement line for each measure.

1 cup

3 cups

2 pints

$1\frac{1}{2}$  liters

$2\frac{1}{2}$  quarts

8 cups

2.8 liters

495 milliliters

3550 milliliters

Use the measurement line to estimate the metric measure for each English measure.

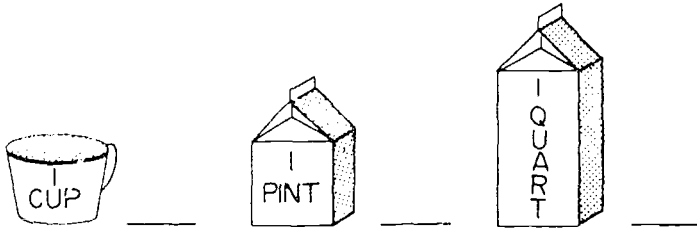

Use the measurement line to estimate the English measure for each metric measure.

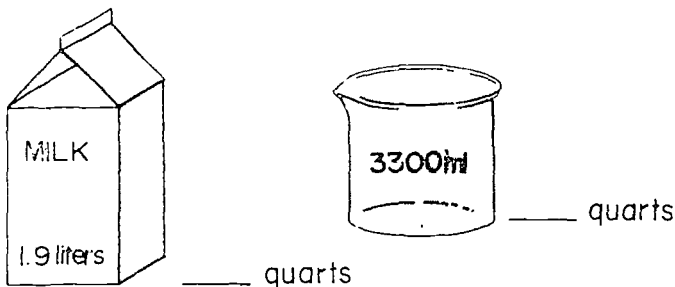



For Teachers

Objective: Experience in using conversion tables: English system to metric system and metric system to English system

Grade level: 5 or 6

Directions for teachers:

1. For each student, reproduce the activity sheet and a copy of the conversion tables printed at the end of this section.
2. Have all students study the first two conversion tables. Be sure that they can "read" them and note their relation to each other.
3. Encourage students to work independently.
4. Observe students to be sure they learn to read the tables accurately.

*Comments:* The tables give all measures to the nearest hundredth. The rounding causes some apparent inconsistencies in the tables; for example, 6 centimeters is 3 times 2 centimeters, but the corresponding table entry—2.36 inches—is not precisely 3 times .79 inches. You may wish to discuss this situation with some of your students.

*Answers*

1. **a.** 1 inch    **b.** 8 inches    **c.** 2 inches    **d.** 8 centimeters  
    **e.** 4 inches    **f.** 8 inches
2. **a.** 1 mile    **b.** 2 kilometers    **c.** 6 miles    **d.** 50 kilometers  
    **e.** 20 kilometers    **f.** 100 kilometers
3. **a.** 1 kilogram    **b.** 3 kilograms    **c.** 5 kilograms    **d.** 50 pounds
4. **a.** 25.4 centimeters    **b.** 76.2 centimeters    **c.** 68.58 centimeters



Name \_\_\_\_\_

Use the conversion tables.

1. Draw a ring around the longer measure.

- |                                      |                                      |
|--------------------------------------|--------------------------------------|
| <b>a.</b> 1 centimeter or 1 inch     | <b>b.</b> 8 centimeters or 8 inches  |
| <b>c.</b> 5 centimeters or 2 inches  | <b>d.</b> 8 centimeters or 3 inches  |
| <b>e.</b> 4 inches or 10 centimeters | <b>f.</b> 20 centimeters or 8 inches |

2. Draw a ring around the larger distance.

- |                                     |                                      |
|-------------------------------------|--------------------------------------|
| <b>a.</b> 1 kilometer or 1 mile     | <b>b.</b> 2 kilometers or 1 mile     |
| <b>c.</b> 6 miles or 10 kilometers  | <b>d.</b> 50 kilometers or 30 miles  |
| <b>e.</b> 12 miles or 20 kilometers | <b>f.</b> 60 miles or 100 kilometers |

3. Draw a ring around the heavier weight.

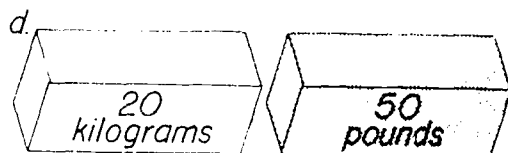
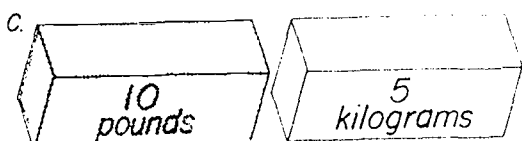
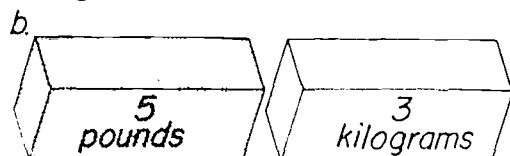
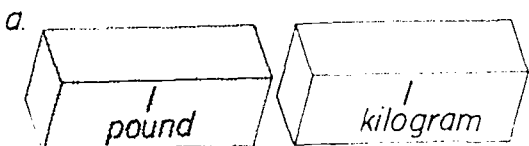

4. Complete each statement to make it true.

- a.** A stick that is 10 inches long is \_\_\_\_\_ centimeters long.
- b.** A line segment that is 30 inches long is \_\_\_\_\_ centimeters long.
- c.** A line segment that is 27 inches long is \_\_\_\_\_ centimeters long.

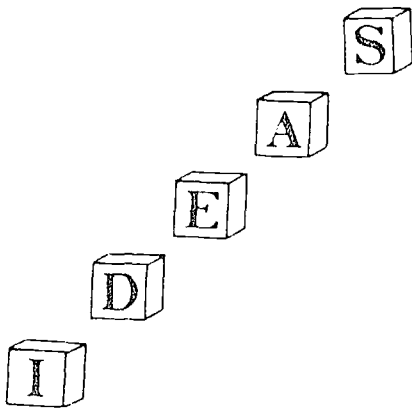

For Teachers

Objective: Experience in using conversion tables: English system to metric system

Grade levels: 6, 7, or 8

Directions for teachers:

1. Reproduce for each student a copy of the Personal Data Sheet and of the conversion tables on the following page.
2. Place these pages on the activity table along with a tape measure, several rulers, and a bathroom scale.
3. Encourage students to fill out their Personal Data Sheet as an individual project. Allow a week for this "extra."

*Comments:* Some students may be sensitive about making "public" some of their personal data. You may avoid unpleasantness by allowing students to skip any data they consider too personal. Sorry, it is impossible to provide answers for the Personal Data Sheet.



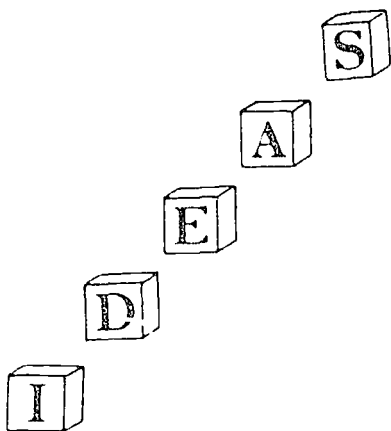

Use your conversion tables to help you complete this sheet.

### PERSONAL DATA SHEET

Name: \_\_\_\_\_ Date: \_\_\_\_\_

Age: \_\_\_\_\_ years \_\_\_\_\_ months

1. Height: \_\_\_\_\_ feet \_\_\_\_\_ inches

\_\_\_\_\_ centimeters

\_\_\_\_\_ meters

2. Weight: \_\_\_\_\_ pounds

\_\_\_\_\_ kilograms

\_\_\_\_\_ grams

3. Waist: \_\_\_\_\_ inches \_\_\_\_\_ centimeters

4. Chest: \_\_\_\_\_ inches \_\_\_\_\_ centimeters

5. Span: \_\_\_\_\_ inches; \_\_\_\_\_ centimeters

6. Reach: \_\_\_\_\_ inches; \_\_\_\_\_ centimeters

7. Pace: \_\_\_\_\_ inches; \_\_\_\_\_ centimeters

8. Length of shoe: \_\_\_\_\_ inches; \_\_\_\_\_ centimeters

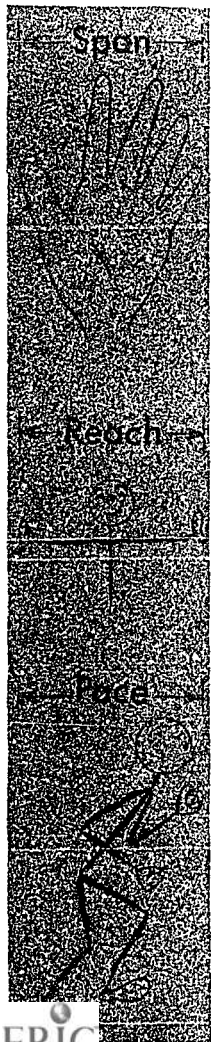

# CONVERSION TABLES

6.5/66

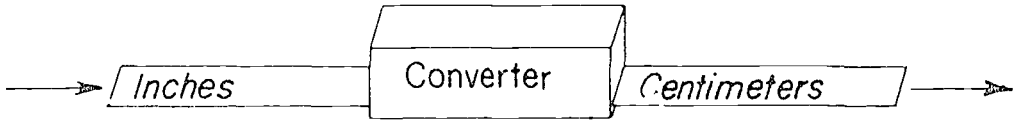

Inches	1	2	3	4	5	6	7	8	9
Centimeters	2.54	5.08	7.62	10.16	12.70	15.24	17.78	20.32	22.86

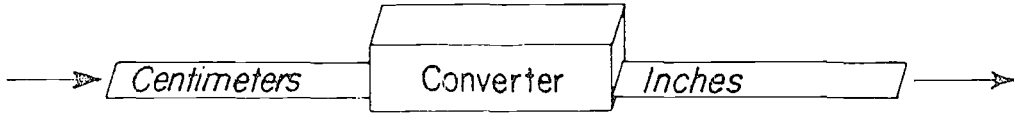

Centimeters	1	2	3	4	5	6	7	8	9
Inches	.39	.79	1.18	1.57	1.97	2.36	2.76	3.15	3.54

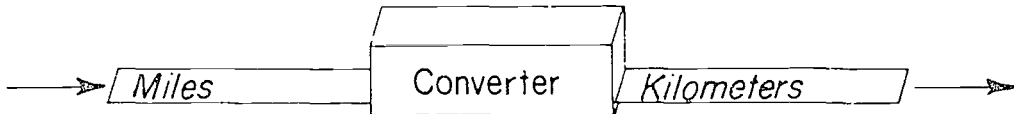

Miles	1	2	3	4	5	6	7	8	9
Kilometers	1.61	3.22	4.83	6.44	8.05	9.66	11.27	12.87	14.48

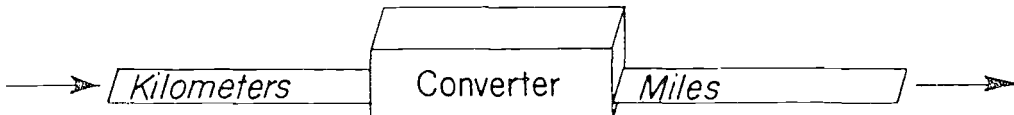

Kilometers	1	2	3	4	5	6	7	8	9
Miles	.62	1.24	1.86	2.49	3.11	3.73	4.35	4.97	5.59

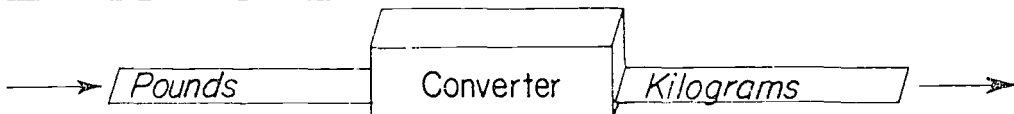

Pounds	1	2	3	4	5	6	7	8	9
Kilograms	45	91	1.36	1.81	2.27	2.72	3.18	3.63	4.08

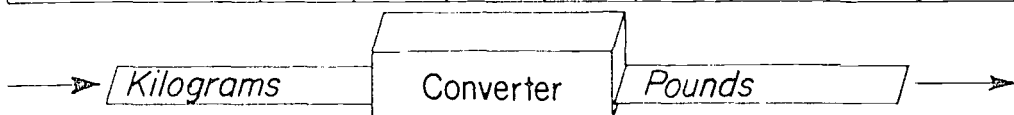

Kilograms	1	2	3	4	5	6	7	8	9
Pounds	2.20	4.41	6.61	8.82	11.02	13.23	15.43	17.64	19.84

*Teaching the Metric System: Guidelines*

# Schools are going metric

FRED J. HELGREN

*A retired research chemist, Fred Helgren has been an officer in the Metric Association, an organization that prepares and distributes metric educational aids. He has been active in promoting the adoption of the metric system to replace the several systems now in use in the United States.*

Forget the length of King Edgar's foot, the length from the nose to the tip of the finger, the length of three barley corns laid end to end, the amount of land that can be plowed by a yoke of oxen in one day. Forget, if you have not already done so, the number of square feet in an acre, the difference between a dry quart and a liquid quart, the number of pecks in a bushel, and all the rest of the system of measures that are learned with difficulty and forgotten with the greatest of ease.

The legal system of measure in the United States is actually the metric system. It was adopted by an act of Congress in 1866. Children should have been educated in this language of measure following that important step in the improvement of our systems of measure. Charles Sumner, the senator from Massachusetts who sponsored the Metric Bill of 1866 that made the metric system legal in the United States, stated at that time, "They who have already passed a certain period of life may not adopt it, but the rising generation will embrace it and ever afterward number it among the choicest possessions of an advanced civilization."

The sciences saw the advantages of the metric system, adopted it, and have used it almost exclusively. It was not, however, accepted for general use, and schools approached the use of the metric system in a way that gave it little encouragement. The

following are some of the poorly conceived practices:

1. Metric measure was not studied as a system by itself.
2. People were not taught to THINK METRIC.
3. Textbooks often contained only a single unit on the system, and problems were merely conversions from one system to the other.
4. The unit on the metric system was frequently at the end of the textbook. As a result, it was seldom taught. Teachers had little knowledge of the system, and it was omitted because of lack of time.

Now a new day has dawned. Following the three-year metric study by the National Bureau of Standards and the Secretary of Commerce, Maurice H. Stans, who was Secretary of Commerce in 1971 when the study was completed, made the following recommendations to the Congress of the United States:

- That the United States change to the International Metric System deliberately and carefully;
- That this be done through a coordinated national program;
- That the Congress establish a target date of ten years ahead;
- That there be a firm government commitment to this goal;

- That early priority be given to educating every American schoolchild and the public at large to think in metric terms.

There is no need for our schools to wait for the Congress to act. There is good reason to feel that they will act, setting a target date ten years ahead, beginning in the year 1973. The metric conversion bill, S-2483, was passed in August, 1972 by unanimous voice vote in the Senate. The House can be expected to vote for the change, and the President supports the bill.

What should be done in the field of education to GO METRIC?

1. Teach the metric system by itself so that teachers and pupils learn to think in this language of measure. Do not try to learn or teach the metric system through conversion problems, and do not try to learn conversion factors. Learn the metric system by itself. THINK METRIC.

2. Change mathematics and science textbooks so that only metric units of measure are used.

3. Before textbooks are changed, get metric workbooks for each teacher and each pupil. Then the system can be learned with very little individual effort.

4. Select one member of the faculty to be the metric authority for the school. He can get the information and materials necessary to enable the school to GO METRIC.

5. Encourage teachers to become members of an organization that will send them literature that explains the metric system, provides information on sources of educational aids, and publishes a newsletter that will keep them alert to metric progress and developments in the teaching of units of measure and their use.

6. Teach the metric system to all prospective teachers, for the change to the new system of measure is not just a mathematics or science project.

The working units of the metric system are easy to learn. The unit of length is the meter (or metre); the unit for mass is the gram; and the unit for volume, the liter (or litre). To THINK METRIC, it is well to learn the three basic units in combination with the prefixes *milli*, *centi*, and *kilo*.

*milli* means  $\frac{1}{1000}$

*centi* means  $\frac{1}{100}$

*kilo* means 1000

For practical purposes, the whole system can be summarized as follows:

1000 millimeters (mm)	= 1 meter (m)
10 mm	= 1 centimeter (cm)
1000 m	= 1 kilometer (km)
1000 milligrams (mg)	= 1 gram (g)
1000 g	= 1 kilogram (kg)
1000 kg	= 1 metric ton (t)
1000 milliliters (ml)	= 1 liter (l)
1000 cubic centimeters (cm <sup>3</sup> )	= 1 cubic decimeter (dm <sup>3</sup> )

The milliliter and the cubic centimeter have the same volume. The term *kiloliter* is not recommended—it is equal to a cubic meter (m<sup>3</sup>), which is more easily understood and used.

Machinists measure in millimeters; tradesmen measure in centimeters and meters; clothing sizes are given in centimeters. And greater lengths are in meters and kilometers. Mass is measured in milligrams, grams, and kilograms by the chemist; grams and kilograms by the shopper; and kilograms and metric tons when large quantities are involved. (Mass is the quantity of matter, whereas weight is a force, the earth's attraction for a given mass. Generally, the term *mass* is meant when we use *weight*.) Physicians, pharmacists, chemists, and bacteriologists use the terms milliliter, cubic centimeter, and liter. Consumers will make purchases of gasoline and other liquids in liters; large quantities will be sold by the cubic meter. Through everyday uses the metric system can be learned in a short time.

In conclusion, I repeat the recommendation made by the former Secretary of Commerce, Mr. Maurice H. Stans, that early priority be given to educating every American schoolchild and the public at large to think in metric terms.

For the price of \$3, the following materials can be obtained from the Metric Association, 2004 Ash Street, Waukegan, IL 60085, a nonprofit organization in-

terested in the dissemination of metric educational materials and information:

- One 20 cm plastic ruler
- Two 1.5 m plastic, flexible measuring tapes
- Two copies of *Metric Units of Measure*, a booklet
- One copy of *Metric Supplement to Science and Mathematics*, a workbook for use by the teacher and the pupil
- One 60 METRIC bumper sticker
- One price list of metric educational aids
- A copy of the last newsletter
- An annual membership in the Metric Association that includes a subscription to the quarterly newsletter

# Metric: not *if*, but *how*

NCTM METRIC IMPLEMENTATION COMMITTEE

The metric system will soon become the major way by which we measure

- the height of a person,
- the mass (weight) of a hamburger,
- the area of a carpet,
- the room temperature at which we are comfortable.

A metrication bill is likely to be passed in the current session of the United States Congress - the Senate passed a metrication bill in a previous session. Business and industry have already taken strides toward complete metrication in an effort to enhance their position in the world market. The automobile industry, for example, is producing engines and even complete automobiles to metric specifications.

The metric system will be the major system used by students now in school throughout most of their adult life. So schools are now beginning to teach metrication to all pupils. As mathematics educators, we have a responsibility for providing leadership and direction in metrication so that these young people will be competent in day-to-day life with measurement in the metric system. We need to think carefully about the implications for each level of schooling:

What can be learned and understood thoroughly at the various grade levels?

What approach should be taken with students who have some knowledge of both the American<sup>1</sup> and metric systems?

What are the needs of students and of our colleagues in courses outside mathematics in home economics, science, industrial arts, or geography?

What responsibility does the mathematics education community have for the education of parents, and for aiding the media or any others who present metrication to the public?

The slogan of the National Council of Teachers of Mathematics is THINK METRIC, which emphasizes thinking in the metric system. What does it mean to think and to function effectively in any measurement system?

## General guidelines for teaching measurement

It is imperative that we use metrication as a means to putting new vigor in the teaching of measurement. Too often the study of measurement has consisted only of written exercises on worksheets or pages from textbooks, with major emphasis on conversions between units and on operations with so-called "denominate numbers." The lack of attention to activities that encourage thinking and estimating in a measurement system has meant that measurement has been viewed as dry and dull by pupils and that our instruction is not adequate for the students' real needs. What, then, should guide us in planning a sequence of activities that will put new life in the study of measurement and assure that major ideas are taught and learned?

1. *Choose an appropriate unit of measure and use it to measure a variety of objects.* The most important component of thinking in any measurement system is a thorough understanding of the unit used most often. In the American system, the initial major unit probably is the foot; in the metric system, it is likely the meter or centimeter. Repeated experiences with the basic unit should lead to estimation of lengths with no more than about ten percent error.

1. The term *American*, rather than *British*, is used because the British have adopted the metric system; the system used in the United States is no longer the British System.

To highlight the nature of the measuring process, and to emphasize the arbitrary nature of standard units, it is advisable to begin with a nonstandard unit. For length, straws, pencils, or paste sticks are readily available and easily used. From such experience a standard unit, such as a meter, can be made from string or cardboard and used by pupils with a double goal learning about measuring length and learning the meter as a unit.

The unit chosen should be appropriate to the size of the object measured. You would not use a kilometer to measure the length of a room, nor would you use a millimeter; you would likely use a meter.

2. *Use multiples of the basic unit, as the need arises for a larger unit, and subdivisions of the basic unit, where smaller units are needed.* By referring larger and smaller units back to the basic unit, which is well known, estimation of larger and smaller units is easier. Furthermore the construction of a measuring system becomes more evident.

Limitation of the number of larger and smaller units taught makes the learning goals more realistic and more manageable. The goal of thorough learning of a few larger and smaller units is much preferred to mere acquaintance with many different units.

3. *Limit expectations of mastery of conversions within a measuring system to commonly used units adjacent in size.* In the American system, feet are usually related to miles, and inches are related to feet; but not inches to miles. In metric, centimeters are usually related to meters, millimeters to centimeters; but very little is done in relating millimeters to meters.

4. *Use the approximate nature of the measuring process in the physical world as a theme.* Helping children to give measurements using language such as "more than 2 meters but less than 3 meters" and "a little more than a kilogram" provides experience with approximation. It also

points to the needs for smaller units and fractional numbers.

5. *Use measurement as motivation for fractions, for decimals, and for arithmetic.* There is no source of applications of arithmetic quite comparable to those that arise from measurement. An active measurement program provides a needed stimulus for learning many topics in arithmetic that are considered important to teach.

6. *Use the actual units as often as possible; avoid the scaled-down versions often found in textbooks or worksheets.* It is folly to try to teach the meter by drawing a scale version of it. Students have great trouble in responding to measurement questions and estimates using such "distorted" representations. The time for scaled drawings is much later, after the initial units are well learned and well understood.

No matter whether it is the American or the metric system, a sense of active involvement is essential. New life will emerge from measurement if simple relationships are emphasized, more estimation is done, and the process is directly taught—especially at an early age. The flavor of "hands-on" experience is much more important than anything else. Creative and interesting activities can be developed and can be used in the full range of management schemes from whole-class to independent work.

#### **Specific guides for teaching the metric system**

With an active point of view about measurement in general, what guides should be used specifically for teaching metric?

1. *In the elementary school, teach metric and American systems as dual systems.* This means that the major emphasis is on teaching the metric system in itself, with relatively little attention to the relation of units between the two systems; we want to encourage thinking within a system.

The need for American units in everyday affairs is likely to persist for some time after the adoption of metric units. Even though



Betty Crocker is in the process of changing measures in recipes to metric, many old but good cookbooks will still be around! When we do become fully metric—four to eight years from now—we shall be able to phase out the teaching of the American system.

2. *Begin with the metric system.* The major adult usage by our present-day pupils will be metric. By teaching it first, we show its importance and we provide the needed framework for its eventual emergence as the only system. Further, we avoid the tendency to overstress conversion.

3. *For children in the middle and upper grades, begin measurement with the meter as the basic unit. For children at the primary level, who have trouble handling so large a unit, begin with the centimeter, or with a unit of 10 centimeters.* The 10-centimeter unit serves the needs of young children and is neither too large nor too small for them to handle. The name *10 centimeters* can help in counting by tens.

For mass (weight) the basic unit is the kilogram; and for volume, the liter. These units should be learned initially, before studying multiples and subdivisions of them.

4. *Teach only the commonly used multiples and subdivisions, and their corresponding prefixes.* Such an approach minimizes the number of prefixes and units a pupil is required to learn. The units shown in table 1 are sufficient through grade 6. Note that the prefixes *deka* and *hecto* are not included because of their rare use. *Deci* is used more often than *deka* or *hecto*, but it is less used than *centi* or *milli*; hence it is omitted.

A few other prefixes are needed in more advanced science courses; for example, milligram for weight in medicine. Such

specialized uses should be left to the science courses and taught there.

Language usage should be natural and unforced. Teachers should try to use the language and symbols correctly, however. Pupils will not use periods behind symbols for the units if the teacher uses no periods.

5. *For pupils who already know both metric and American systems, and for parents, approximate conversions can be made.* Activities involving approximate conversions might be deliberately planned for pupils in the upper grades. Students should be taught approximate equivalents that allow them to estimate in either system, given a measure in the other.

The following list is suggested:

*1 kilogram is a little more than 2 pounds*  
*1 meter is a little more than 1 yard*  
*1 kilometer is a little more than 1/2 mile*  
*1 liter is a little more than 1 quart*

There is, however, almost no need for any paper-pencil conversions between metric and American. It is important that the emphasis be on understanding the two systems, and that the arithmetic of conversions be minimal.

#### *Grade placement of metric topics*

The question arises directly, what should be the placement of metric topics? One suggestion on placement is the following:

Meter and centimeter can be introduced at the primary level and reinforced at all subsequent levels. The initial work should be done to emphasize estimation with the basic unit.

Tenth of a centimeter—the millimeter—can be the topic for middle and upper grades. Decimal notation will be helpful.

Weight, which is more difficult to estimate and so requires more maturity on the part of students, may be introduced in upper primary, first using the kilogram. The gram can appear in the middle grades.

Capacity or volume, using the liter as the first unit, can be introduced in the upper

**Table 1**

Length	Mass (weight)	Capacity
kilometer (km)	kilogram (kg)	
meter (m)	gram (g)	liter (l)
centimeter (cm)		
millimeter (mm)		milliliter (ml)

primary, with the milliliter—also called a cubic centimeter—appearing in the middle grades.

Celsius temperature can be introduced at any level.

Much of the current material on today's market does not deal with the really significant concepts of the metric system and measurement. Rather, it tends to be a series of paper-pencil activities using the gamut of metric notions, without regard for the principles of estimation and measurement, or for the components of the metric system that our students will find necessary. For example, present-day metric materials often ask students to perform complicated and useless conversions within the metric system itself changing mm to m, km to dm, or mm to dm. Just as useless are exercises requiring addition of unlike units such as dm and m. Rarely are units mixed in a metric problem. Instead of using 3 dm 5 cm, the measure would be given as 35 cm. Instead of 3 m 22 cm, we would say 322 cm or 3.22 m. Poor instructional materials make the metric system seem complicated for children when it is relatively easy. Such materials should be screened and not purchased.

#### *Metrication in the community*

Schools should be expected to help parents understand the metric system. Parents will want information on what their children are being taught so they can provide reinforcement at home. School people in general, and mathematics educators in particular, should take the initiative in presenting metrication to the community. Let us not make the mistake of waiting for parents to demand it. It is our responsibility. Creative teachers can prepare single-concept handouts to send home periodically to the parents. Perhaps a metric newsletter can be developed with teacher and student input. Libraries could prepare displays of metric materials. For some school districts there is the possibility of developing parent workshops as an activity of the parent-

teacher organization. Metric education is our responsibility and we have the equal tasks of working with our students and with our community.

#### **Conclusions**

Our goal of metrication in the school program is realistic. The amount of new knowledge required is actually quite small. Success for the mathematics education community in making the change will depend on how well we follow guidelines such as those given here. It will depend on the degree to which we provide appropriate experiences for maximum development of student understanding.

In summary, these are the guidelines:

Teach students to THINK METRIC.

Concentrate on those units necessary from the utilitarian standpoint.

Develop meaning and feeling for units through experiences centering around estimating, and checking of the estimates.

Minimize conversions. Do not immerse students in the morass of computing conversions between the metric and American systems nor even within the metric system itself.

Use metric units at every opportunity. This includes use in other subject-matter fields. Elementary teachers—use them throughout the day. Secondary teachers—teach metric exclusively and provide inservice materials for your colleagues in other subject areas.

**METRICATION IS UPON US. IT IS NOT IF, BUT HOW.**

*NCTM Metric Implementation  
Committee*

Boyd Henry, *Chairman*  
Stuart A. Choate  
Donald Firl

# Teaching the metric system as part of compulsory conversion in the United States

VINCENT J. HAWKINS

*A mathematics teacher at Toll Gate High School in  
Warwick, Rhode Island, Vincent Hawkins is also serving as research  
coordinator for the Toll Gate Metrication Project.*

There is no doubt that the metric system is rapidly becoming the standard system of measures for the entire world. Over ninety percent of the countries have already adopted the system. Even England, from whom we inherited our customary system of weights and measures, is more than halfway through its own ten-year program of conversion.

The main fact emerging from the recent study of the National Bureau of Standards is that conversion is inevitable—the only questions are *when* and *how*. The recommended *when* is at the end of ten years, thus providing time to plan for and make the change. The *how* can be answered twofold:

1. Constant exposure to the metric system through advertisement, conversation, relabeling of all commercial goods, along with a continual phaseout of the customary system.
2. Proper educational programs of instruction on four different levels from pre-school through high school.

Since the British are still in the process of conversion, a complete report on the educational aspects of British metrication is not available. We do know that from the beginning the British counted quite heavily on the education system to make metrication

a smooth, gradual process. English students who are now entering the elementary grades are learning to think in metric terms as naturally as their parents thought in terms of inches and pounds. Students in the higher grades are successfully breaking the habit of thinking in the old terms. The book publishers and educational equipment suppliers are well ahead in production to conform to the metric system. Teachers are being trained in special courses to teach the system effectively.

The proper education of students, using a master plan that involves all grades, is the most important factor for a successful conversion. An educational survey, conducted as part of the U.S. Metric Study, showed that changing textbooks and equipment would cost about \$1 billion. If these changes were made for no other purpose than for conversion, then the expense could be tabbed wholly to metrication. The fact is, however, that most textbooks are replaced after a few years of use. The bulk of the expense of conversion can be absorbed with regular revisions that provide a planned exposure to the metric system.

Most educators agree that learning the metric system is quite easy. The simplicity of metric tables leads to the assertion that the metric system can be learned in just one hour, and continual work at applications

would make the system completely second nature at the end of one year. Young people are more receptive to the system than their elders are. In fact, partly due to the psychological effect of a totally new system based on ten, the slow learner learns the metric system more readily than he learns the customary system. In the English system, there are more terms to learn: *inch, foot, yard, mile, acre, ounce, pound, ton, pint, quart, gallon, peck, bushel, dozen, and gross*. In the metric system, a child needs to learn only eight terms: *meter, liter, and gram*; the prefixes *milli-, centi-, and kilo-*, and *hectare and metric ton*.

Once metrication has been given the green light, the metric system can become an integral part of the mathematics curriculum for each of the grades. The approach to the metric system will need to be adapted to the various grade levels.

#### Preschool

Up to age five, children should be exposed to the metric system as a standard system of measurement, even though their parents will still be using the English system for everyday, practical purposes. The family should help children realize that one system of measures is on the way in, and the other is on the way out. Children should be encouraged to use metric units. Educational programs would help the preschooler realize that what he is learning is extremely useful in everyday life. Educational toys and planned television programs could be beneficial.

#### Kindergarten

At this age, children are exposed to the idea of size—large versus small, tall versus short, and heavy versus light. Students should learn to associate the basic units with familiar objects: the meter as something that is slightly taller, or shorter, than they are; a decimeter as long as, say, a sharpened pencil; and a liter of water as about the same amount as a quart of water, and weighing about the same as a book like a dictionary.

#### First grade

Addition and subtraction can be taught using the meter stick as a number line. The introduction of the fraction  $\frac{1}{2}$  should be accompanied by the introduction of the millimeter as a part of the centimeter. Students should be taught that  $\frac{1}{2}$  is equivalent to  $\frac{5}{10}$  and  $\frac{50}{100}$ . They should examine two different containers of  $\frac{1}{2}$ -liter capacity, but of different shape, and find that both can be used to fill a 1-liter container.

#### Second grade

Students at this level learn about making change, inequalities, and large numbers. The teacher can show the relationship between terms—how *cent* is related to *centi*; how *mill* is related to *milli*. The concepts of *more than* and *less than* can be illustrated: thirteen centimeters is more than one decimeter. One dime is less than \$0.13. Students should learn that there are 100 centimeters in 1 meter, 100 millimeters in 1 decimeter, 100 decimeters in 1 dekameter, and so on. Groupings of 100 to form 1000, and groupings of 10 to form 1000 can be studied with the help of the metric tools.

Normally at this stage, fractions such as  $\frac{1}{3}$ ,  $\frac{1}{4}$ ,  $\frac{1}{5}$ ,  $\frac{2}{3}$ , and  $\frac{3}{4}$  are studied. In the study of metric measurement, these are passed over. Students will learn the tenths instead— $\frac{1}{10}$ ,  $\frac{2}{10}$ ,  $\frac{3}{10}$ , and so on.

#### Third grade

Sums up to 100 can be associated with the meter stick. For example: How many decimeters and how many centimeters should be added to reach the 95 on the meter stick? The introduction of the Celsius thermometer, with 0 degrees freezing and 100 degrees boiling, provides further opportunities for additions up to 100. Concepts of larger numbers can be introduced with the number of millimeters in a meter. The degree of error can be introduced with the idea of the nearest half centimeter. This ties in with inequalities on the meter stick.

With the introduction of area and volume, students learn the terms *square* and *cube*, and they should be taught estimation. For example: How many squares one meter long on each side do you think will cover this floor? Or, How many liters of water do you think it will take to fill this tank? Foreign road maps can be used for the introduction of the kilometer and the hectare. By this time in their academic career, students should be well aware of the importance that ten has in everyday life, as well as in all mathematics.

#### Fourth grade

Averages of metric measures can be found. It is important that equivalence be learned thoroughly. Students should know that 97 on the meter stick means  $97_{1000}$  meter, or  $97_{10}$  decimeters, or 97 centimeters, or 970 millimeters, and what must be added to each of these to obtain the equivalent of one meter. The process of finding the least common denominator for the purposes of measurement is practically trivial. Weights are taught at this level, and the gram should be learned in association with such things as a small piece of chalk. The kilogram can be illustrated with a heavy book and, possibly, in association with capacity—the relation of a kilogram to a liter of water. Decimals can be taught entirely by the metric system. Common fractions can also be related to the metric system. The example  $9\text{ m} + 7\text{ dm} + 33\text{ cm}$  can also be expressed as  $9_{1} + 7_{10} + 33_{100}$ . This example, of course, can be changed entirely to meters, decimeters, or centimeters. There is no confusion with the least common denominator as there would be with the customary system. The relationship between the shifting of the decimal point and the corresponding fraction should be evident.

#### Fifth grade

For further practice at this level, students will be exposed to more difficult material. The terminology of the metric system should be implemented as much as pos-

sible. Problems in multiplication and division in measurement can be studied at this time. A typical example in multiplication might be

$$(6.5)(1\text{ m } 7\text{ dm } 2\text{ cm}) = (6.5)(1.72\text{ m}) \\ = 11.18\text{ m}$$

Of course, finding the decimal equivalent of a measure must be learned. Manipulation of measures becomes easier for students because there is less mechanical work.

#### Sixth grade

Time, rate, and distance problems with metric units are not usually taught until a physics course is taken. However, with the national changeover to metric, this is brought down to the lower grades, which gives more time for other things in physics. The use of the metric system can facilitate the more complicated inequalities with fractions, especially in area, volume, and perimeter. The liter should be studied more carefully, with applications in both capacity and weight—a tub that is 1 meter by 1 meter by 1 meter will take 1000 liters to fill it, and each liter of water weighs 1 kilogram. An experiment with several students using a seesaw is a way to show comparisons. The introduction of percents, with further work in the degree of error, can be taught using centimeters.

The metric study in the sixth grade should also include a film documentary on the history of the system and its worldwide use, with examples in commerce and industry.

#### Junior high school

Students should know what a square centimeter looks like and that 100 square centimeters covers an area equal to 1 square decimeter ( $100\text{ cm}^2 = 1\text{ dm}^2$ ), and so on. They should be somewhat familiar with the notation  $\text{cm}^2$ . Fractional parts of square units should be taught. For example,  $1/2\text{ cm}^2$  may be a rectangle that is 1 centimeter in length and 5 millimeters in width, with

an area equal to 50 square millimeters. After such simple ideas are learned, students should have no difficulty in finding the area of any simple geometrical figure using fractions or decimals.

In the first year of junior high school, the student should have plenty of practice in applying his knowledge of linear measure to the formulas. Volume and its relationship to weight are studied in the second year. Students should be shown models of cubes, cylinders, and the like for help in visual perception. The use of metric units in the formulas should not be a problem; but, again, notation needs to be explained. The notation for cubic centimeters is  $\text{cm}^3$ . A volume of  $1\frac{1}{2} \text{ cm}^3$  is equivalent to a rectangular solid 1 centimeter by 1 centimeter by 5 millimeters. As in area, work with fractions and decimals in volume is important, and not difficult, as long as the students know all the components of linear measure.

In working with volume and capacity, the basic thing to know is that 1 liter contains 1000 cubic centimeters ( $1 \text{ l} = 1000 \text{ cm}^3$ ). All expansions of capacity into meters or cubic meters, or reductions of capacity into millimeters or cubic millimeters, can be done easily. More work with inequalities can be provided. For example:

Complete with  $>$ ,  $<$ , or  $=$  :  
 .001 liter . . . 1 cubic centimeter

The laboratory approach would be an obvious aid in this type of instruction.

The third year of the junior high should be given to more difficult applications of all previous work with the metric system. The only new topic that needs to be covered is scientific notation.

### Senior high school

The metric system is taught in the traditional way in high school science classes. Work with the metric system can be continued in courses like geometry and trigonometry, with applications to problems involving measurement.

There are two important points to make clear:

1. The metric system should be taught as a primary language.
2. Conversion manipulation should not be used at all.

The model program outlined here is designed for the graduated exposure of students to the metric system. The exclusive use of the metric system will reduce the need for common fractions and, thus, the time given to teaching fractions. Estimates vary, but mathematics teachers say that in the elementary schools fifteen to twenty-five percent of class time is spent teaching the details of adding, subtracting, multiplying, and dividing common fractions. They believe that much of this is unnecessary. As Lee Edson pointed out in *American Education*, if the metric system, with its simpler decimal relationships, were taught, teachers could quickly and easily give their pupils the basic principles of fractions and then continue to other aspects of mathematics.

There is no doubt that the schools are the key to complete metrication. Few adults who have lived with the inch-pound system all their lives will ever completely learn to THINK METRIC, but children who are introduced to the system when they start school, and even before, will always THINK METRIC.

During the period of metrication, not all school children will be exposed to the metric system in the same manner. There are four categories of exposure:

1. *Basic*, for the preschooler and grades one and two.
2. *Lower intermediate*, for grades three, four, and five.
3. *Upper intermediate*, for grades six, seven, eight, and nine.
4. *Advanced*, for applications in the physical sciences, such as chemistry and physics.

Table 1 is a chart of how the categories might be distributed for the successive

**Table 1**  
**Programmed conversion chart**

	Year of metrication									
	1	2	3	4	5	6	7	8	9	10
Kindergarten	B	B	B	B	B	B	B	B	B	B
First grade	B	B	B	B	B	B	B	B	B	B
Second grade	B	B	B	B	B	B	B	B	B	B
Third grade	50% B 50% L	25% B 75% L	L	L	L	L	L	L	L	L
Fourth grade	50% B 50% L	30% B 70% L	25% B 75% L	L	L	L	L	L	L	L
Fifth grade	50% B 50% L	40% B 60% L	25% B 75% L	L	L	L	L	L	L	L
Sixth grade and plus	40% B 60% L	25% B 75% L	25% L 75% U	50% L 50% U	25% L 75% U	U	U	U	U	U

B = Basic  
L = Lower intermediate  
U = Upper intermediate

years of conversion. For example, if a student entered the seventh grade during the initial year of conversion, what would he study? For the first two years he would be instructed in the basic and lower-intermediate phases. When he had the appropriate competence, the upper-intermediate phase would follow. Since all of this is presumably new to the student, it is important that no mention of the English system, for comparison or conversion, be made. With much applied use, the student will see the simple relationships for himself and make the necessary mental conversions.

To help students in their learning, the metric system should always be in evidence—displays in the classroom can include such things as foreign road maps; 16-mm and 35-mm strips of film; cultured pearls; military shell casings; wall charts, like those distributed by the Department of Commerce; snow skis; and of course, a complete set of the standards of the units of measurement of the metric system.

There is no doubt that the change to the metric system is an enormous undertaking

But neither is there any doubt about the benefits that will result. The physical aspects of converting—changes in industry and the like—can be described in dollars and cents, but mental conversion cannot be measured. There will always be the unconvinced people who feel that the present system is perfect and that perfection should not be tampered with. It is generally true that nearly all of us proceed on the assumption that whatever is, is right. This is probably the major reason why America has been afraid of metrication. Many people, in the United States and around the world, want this problem overcome, and the way to do it is through education.

### References

- Edson, Lee. "Metrication." *American Education* (April 1972): 10-14.
- Halsey, Frederick. *The Metric Fallacy*. Washington, D.C.: American Institute of Weights and Measures, 1920.
- Manchester, Harland. "Here Comes the Meter," *Reader's Digest* 100 (April 1972): 19.

# Metric curriculum: scope, sequence, and guidelines

MARILYN N. SUYDAM

The metric system is merely a system of measurement that replaces another system of measurement. However, metrication provides the opportunity to: (1) reevaluate the measurement component of the mathematics curriculum; (2) reconsider what we know from experience and from research about how children learn measurement concepts; and (3) restructure the curriculum and modify instructional practices. The scope and sequence suggestions and the guidelines that follow are not exhaustive; they are intended to call attention to some of the important factors to keep in mind when planning a program.

## Scope and sequence suggestions

### Primary level

1. Develop the basic prerequisite skills and understandings about measurement by having the student—
  - a. Match, sort, and compare objects—long/short, heavy/light, large/small, and so on.
  - b. Make direct comparisons of two objects by placing them next to each other to determine which is longer or shorter, heavier or lighter, larger or smaller, and so on.
  - c. Compare three objects, developing the idea of transitivity (that is, if  $A$  is

shorter than  $B$  and  $B$  is shorter than  $C$ , then  $A$  is shorter than  $C$ ).

- d. Place several objects in order, from longest to shortest, heaviest to lightest, and so on.

- e. Make direct comparisons by using a third, larger unit to describe the comparisons. For instance, give the child three sticks. Have him tell the length of the first and second sticks in terms of the length of the third stick.

- f. Combine lengths, masses, and volumes, using physical objects. For instance, put the water from four glasses into one container, or put two desks together.

- g. Transform objects for comparison, applying the idea of conservation (that no length, mass, or volume is lost in the process). For instance, pour sand that is in two differently shaped containers into two similar containers.

- h. Compare by iteration—placing objects end to end a number of times, pouring over and over, and so on. This relates measurement to a process of counting.

- i. Use metric measures in “play” activities. Metric measures and terms should be used in everyday experiences, although the metric system itself is not under discussion. Metric terms should be used, for instance, when recording temperatures on a daily calendar or marking heights of pupils on a wall hanging.

2. Extend the concept of measurement by using nonstandard (arbitrary) units.

- a. Use varying units. For instance, give each student a different length of string;

---

Adapted from materials published and copyrighted by the Agency for Instructional Television, 1974. Used by permission.



have the student measure an object and report his measures in terms of that length. Develop the reason for using a common measure—communication with others.

*b.* Have the class choose an appropriate (common) unit and use it to make indirect comparisons. Measure a variety of objects: using John's foot as the unit, have each child make a copy (model) of the length of John's foot and use it to measure the room desks, and so on. Even when a common unit is used, their measures will probably not all agree; discuss the approximate-ness of their measurements.

*c.* Measure between limits, reporting the measurements as "between 2 and 3 units," for example.

*d.* As the need arises for a larger unit, use multiples of the basic unit; subdivide the basic unit when smaller units will facilitate more accurate measurement. (Since we have a decimal system of numeration based on powers of 10, it follows that for ease of calculation the subdivision of the units should also be based on 10. Measurement with the metric system can thus be integrated with other topics in the curriculum.)

*e.* Develop the idea that a common standard unit is needed for communication with others outside the one classroom.

3. Having established the background for developing a decimal standard system of measurement, gradually introduce the various standard units of the metric system and the instruments used to measure in these units. (This listing is general; many specifics must be added.)

*a.* The meter and centimeter should probably be introduced first. The child should have practice in measuring to the nearest centimeter with the ruler and meter stick. He needs to be taught how to hold the ruler to make careful measurements and how to draw lines that reflect careful measurement. (The child needs similar instruction on how to use other measuring instruments.)

*b.* After some practice in measuring,

the pupil should learn to estimate metric lengths. Begin with gross comparisons ("Is a meter about the length of the school building or about the length of the bookcase?"), then develop finer ones ("About how many meters long is the room?").

*c.* Discuss the need to use appropriate measurement units—centimeters to measure the width of a book, meters to measure the length of a room, kilometers to measure the distance between two cities.

*d.* Begin to develop the relationship of the metric system to the numeration system. For instance, explore counting on a metric ruler and on the meter stick; note the 1:10-100 correspondence.

*e.* Provide activities in weighing with a balance, first using the kilogram, since it is easier to handle than the gram weight. (Weight is a more difficult concept according to research and is more difficult to estimate.)

*f.* Introduce the liter as a unit for measuring volume.

*g.* Develop time concepts related to the hour and minute.

*h.* Use the Celsius thermometer in everyday situations, having the child read and record temperature.

#### *Intermediate level*

1. Develop the relationships between the prefixes, stressing the relationship to the decimal numeration system. Use decimal notation. (The most often used prefixes are milli, centi, deci, and kilo.)

2. Introduce the symbols for the metric units as the unit is introduced: m, dm, cm, mm, km, g, kg, l, ml.

3. Teach the relationships among measures. For instance, for length, develop such relationships as—

10 mm = 1 cm	(emphasis should be placed on these four)
100 mm = 1 dm	
1000 mm = 1 m	
10 cm = 1 dm	
100 cm = 1 m	
1000 m = 1 km	

Later teach such relationships as—

$$1 \text{ mm} = 0.1 \text{ cm} = 0.001 \text{ m}$$

$$1 \text{ cm} = 0.01 \text{ m}$$

$$1 \text{ m} = 0.001 \text{ km}$$

4. Measure to the nearest millimeter; to the nearest milliliter; to the nearest gram. (In the elementary school, the distinction between mass and weight can be noted, but the term "weight" will probably be used. Mass is sometimes thought of as the amount of material in an object. Weight is the measure of gravitational force on a mass and varies with the location of the mass (object). The weight of an astronaut on the moon is less than his weight on the earth because the force of gravity is less on the moon; he may be weightless in a space station. His mass, however, is the same in all three places. We have been so accustomed to using the term "weight" incorrectly that it will still probably be used in cases where the correct term is "mass.")

5. Develop understanding of rectangular solids—1 liter = 1 cubic decimeter ( $\text{dm}^3$ ) = 1000 cubic centimeters ( $\text{cm}^3$ ).

6. Convert from one metric measure to another, stressing the relationship to the numeration system (10-100-1000). Develop the ability to convert mentally.

7. Introduce addition and subtraction with common measures. Compare with regrouping in addition and subtraction algorithms. Later use multiplication and division with measures.

8. Develop angle measures (which are the same in both metric and customary systems).

9. Work with metric units in problems on perimeter, area, circumference and area of circles, volume, time, temperature, and so on.

10. Develop understanding of the relationships among units for length, volume, and mass.

11. Develop the idea of accuracy and precision of measurements and of significant digits.

12. Extend time concepts and temperature ideas.

13. Discuss the history of measurement, presenting selected aspects to indicate how varied systems of measurement developed (including but not limited to the customary system of measurement).

#### *Secondary (and adult) level*

1. Units for such quantities as force, pressure, work, power, and electricity should be presented in science and vocational education courses as the need arises.

2. Generally, the problems at the junior and senior high school levels will not be much different from those at the adult level. The very things that will be taught to the elementary school child will also have to be presented to the older student and to the adult. More extensive development of the metric system will be needed in some classes—for example, in science—than in others. Metric units can be presented with limited reference to or comparison with a few customary units. The emphasis should be on making actual measurements with metric instruments. No problems should be presented that involve conversions from customary to metric units or vice versa. The decimal nature of the system should be stressed in realistic problem settings; comparisons to the monetary system may be particularly helpful. The workshop approach, in which the student actually makes all types of measurements with metric instruments, is highly feasible and desirable.

#### **Guidelines for teaching measurement with the metric system**

1. The focus of instruction should be on measurement, with the metric system evolving and taking its role as the standard system of measurement.

2. Before children can understand the metric system or any other system of measurement, they must have experiences in measuring. They must understand what measurement is. Some prerequisite skills and understandings are essential before *any* standard measures are used.

3. After prerequisite knowledge and skills are attained, nonstandard measures should be used to develop the concept of why a standard system of measurement is needed, as well as to extend the concepts of what measuring means and of how things can be measured in various ways. (Only when the child understands how arbitrary the choice of a unit actually is will he realize the importance of standardization in measurement and appreciate that the history of measurement is essentially a struggle for standardization.)

4. The logic of using a measurement system based on ten—to correspond with our numeration system—is then developed, and the metric system is introduced.

5. Begin with linear measures, because the metric units of length are the basic units from which the units of mass and volume are derived. For children in the intermediate grades, begin with the meter as the basic unit; for smaller children who may have difficulty handling the meter stick (and who do not yet know the numbers to 100 sufficiently), begin with the centimeter as the basic unit.

6. In the elementary school, teach the metric system as *the* system of measurement; later, the customary system may be discussed as one of the other systems of measurement. Schools may have to teach some of the customary measures along with teaching the metric system for a while, since the country as a whole will offer examples of both for years to come. Teach the metric and customary systems as dual or alternative systems—the customary system happens to be the one the children's parents used.

7. Avoid conversion exercises, concentrating on use of the metric system. The individual needs to learn metric measurement by itself and thus learn to think in that language of measurement. Children who have not learned any system of measurement will have little difficulty learning and accepting the metric system.

8. Limit conversions within the metric system to commonly used units adjacent

in size. Present-day metric materials often ask students to perform extensive conversions, such as changing kilometers to decimeters. Just as useless are exercises requiring addition of unlike units; rarely will this be needed in actual metric situations. Instead of stating 4 decimeters 3 centimeters, the measure will be given as 43 centimeters; instead of 5 meters 16 centimeters, we will say 516 centimeters or 5.16 meters. Children will need to understand the relationship between measures, but they should be encouraged to use the standard form.

9. Use actual units and measuring instruments; avoid completely the use of scaled-down versions sometimes found in current text materials.

10. Develop the understanding that the appropriate instrument should be used for different measurement purposes: the meter stick for length, the balance for weight (mass), the container for volume, the clock for time, the thermometer for temperature.

11. The units should be introduced at the point at which they are to be used. Concentrate on those units necessary from a utilitarian standpoint at all age levels, including adult. Do not teach the metric-unit tables per se.

12. Estimations should be emphasized, such as, "About how many matchbook covers long is the desk?" or "About how many grams of sugar do you put in a cup of coffee?" Verify estimates with nonstandard measures and later with metric measures. Develop the meaning of and a feeling for the size of units through experiences centering on estimating and checking those estimates.

13. Stress the idea that measurement is approximate. Schools have given children many illustrations of "exact" measures; measurement is not as precise as we have made it seem. Precision is partially dependent on the unit of measurement we use.

14. With pupils who already know the customary system, as well as with adults,

approximate conversions may be needed. Relate metric measures to common objects and to body measures.

The meter is a little longer than a yard.

The liter is a little larger than a quart.

The gram is about the weight of an ordinary paper clip.

The kilogram is a little heavier than 2 pounds.

Body temperature is about 37 C.

15. Use metric units at every opportunity, including other subject matter fields.

16. The prefixes should be introduced as they are needed. Association and presentation of the complete set of prefixes should be done late in the development and then it should be presented only to serve the function of noting the orderliness of the metric system and its relationship to our numeration system. The prefixes kilo, deci, centi, and milli are the only ones that will need to be stressed in the elementary school.

17. Teach only the commonly used

multiples and subdivisions and their corresponding prefixes and symbols; for instance,

m, cm      100 cm = 1 m

mm          10 mm = 1 cm

km          1000 m = 1 km

g, kg        1000 g = 1 kg

l, ml        1000 ml = 1 l

18. Stress the importance of correct symbol usage, which is the same in all languages.

19. Special emphasis should be given to symbols for area and volume units that contain superscripts. Additional emphasis on exponential and scientific notation will be needed in the elementary school.

20. Discourage the use of common fractions with metric units except when needed to develop specific quantitative concepts; when a fractional term is used, write it in decimal form, that is, "one-half" is written as ".5" or "0.5."

*Looking at the Measurement Process*

# Ten basic steps for successful metric measurement

JON L. HIGGINS

As adults we have been measuring for so long that we now tend to take the measuring process for granted. Today's push for conversion to the metric system provides us with new opportunities to redesign not only the system of measurement that we teach in our schools but also the way we teach measurement itself.

Research over the past thirty years suggests that measurement is a much more involved process than we have commonly assumed. Measurement requires the development of several prerequisite skills and understandings that are often overlooked. The following list suggests some of these prerequisites, along with a possible sequence in which they might be developed. The list is intended as a summary. The issues and critical aspects of each step can be found in the other articles in this handbook. We have unified this list to treat length, area, volume, and mass (weight) simultaneously. Researchers have found that many of these understandings must be *developed* by children, instead of merely being *given* by textbooks or teachers, and that a child's development does not proceed simultaneously for length, area, volume, and mass (weight). Nevertheless, the prerequisites are similar for all and can be easily discussed together even though they may be separated in the curriculum. Compare this list of ideas and suggested activities with the textbooks used in your school. Are you skipping any important steps and prerequisites?

1. *Compare directly.* Extend the ideas of "more" or "less" to "longer" and "shorter," "heavier" and "lighter," and "bigger" and "smaller" by placing objects directly next to each other. Be sure to extend the activities to include not only length but also area, volume, and mass (weight) as well. For length, compare pencils, pieces of string, chalk, and so on. For area, compare sheets of paper or similar paper cutouts by placing one over the other. (Keep the shapes being compared geometrically similar at this time.) For volume, compare boxes and cans by placing one inside the other (filling activities should come later). Compare the mass (weight) of objects by lifting and by placing on simple two-pan balances.

2. *Compare three objects.* Three objects  $A$ ,  $B$ , and  $C$  may be compared by comparing  $A$  with  $B$  and  $B$  with  $C$ . Develop the property of transitivity for length, area, volume, and mass (weight): if  $A$  is less than  $B$  and  $B$  is less than  $C$ , then  $A$  is less than  $C$ , which can be verified by a third direct comparison. Note also cases where transitivity does not apply. For example, if  $A$  is less than  $B$  and  $C$  is less than  $B$ , we do not know how  $A$  and  $C$  compare without a direct comparison.

Apply the transitivity principle to compare two widely separated objects. Have one child hold a short pencil on one side of the room, and another child hold a piece of chalk on the other side of the room.

Which looks longer? Choose a third object of intermediate length, perhaps a dowel or stick, and use the transitive property by comparing first the pencil to the dowel and the chalk to the dowel.

3. *Place several objects in order.* Once children have learned and mastered the transitivity properties, they can place several objects in order of increasing or decreasing size by repeated use of transitivity. This serial ordering depends on transitivity, but is not necessary for the steps in measuring that follow.

4. *Compare indirectly.* Basic to the measurement process is the use of a third larger unit that can be used to help compare. We get around the inapplicability of the transitive property by constructing (marking) the size of one object on this larger unit and using the constructed size to compare to the second object. For example, choose a dowel longer than either the pencil or the chalk in the previous example. Compare the dowel to the pencil and mark the pencil's length on the dowel. Then compare the marked length on the dowel to the length of the chalk.

Compare the area of two triangles by tracing one of them on a large sheet of paper (the larger unit). Then carry the marked sheet of paper to the other triangle for comparison.

Two volumes can be compared indirectly by using a volume of either sand or water as an intermediate. As before, the volume of sand or water available must be larger than the volume of either of the two containers being compared. Fill one of the containers with sand or water, discarding the extra (this is the marking or "construction" step). Then compare by pouring the sand or water into the second container.

Masses (weights) may be compared by using sand or water to "construct" a mass equal to the first. The constructed mass may then be compared to the mass of the second object.

5. *Add lengths, areas, volumes, and masses.* Develop the idea that basic prop-

erties can be added. Compare the length of a pencil to the length of two pieces of chalk by placing the chalk pieces end to end.

Compare the area of four small squares to that of a large square by fitting the smaller squares together like a puzzle to form a new area. Compare the volume of several blocks to that of a larger box by stacking the blocks. Compare the weight of several paper clips to that of a safety pin by placing all the paper clips on one pan of a balance and the safety pin on the other.

6. *Transform objects for comparison.* Often it is helpful to transform objects to make them appear more nearly alike for purposes of comparison. Essential to this process is the fact that no length, area, volume, or mass must be lost in the transformation process—this is the basic idea of "conservation."

Form a polygon with toothpicks. Compare the length (perimeter) of the polygon to the length of a pencil by placing the toothpicks end to end to form a straight line.

Compare the area of a triangle to the area of a rectangle by cutting the triangle into pieces that can be fitted together to form a new shape that is approximately a rectangle.

Compare a ball of modeling clay with a block of modeling clay by pinching the corners off the block and adding them back at other spots. Use this same transformation to compare both volume and mass (weight).

7. *Compare by iteration.* Two objects can now be compared by using a third intermediate object that is smaller than either of the objects being compared. A small length is used to construct the length of a pencil by placing copies of the small length end to end until the additive length is equal to that of the pencil. The number of times the small length is used or repeated is counted, and this number becomes the measure of the length of the

pencil. If we want to compare the length of the pencil to the length of a piece of chalk, we can get a number for the measure of the length of the chalk in the same manner and compare lengths by comparing number.

This process is what most people think of when they think of measure. There are two important things to note about it. First of all, the iteration process reduces measurement to a process of counting, but counting is the last step of the measurement process. The steps that we have summarized earlier form the necessary prerequisites for the successful completion of the counting process. Secondly, the intermediate "small length" forms the unit of measurement. When we count, we must be counting equal or congruent units. This is why the repetitive or iteration process is important—it guarantees that we count congruent units. The unit we choose may be arbitrary, as long as we use the same unit for all measurements we wish to compare.

When measuring areas by iteration we may be arbitrary not only in the choice of the size of the unit but in choosing the shape of the unit as well. The problem is to choose a shape for a unit that can be used to construct many differently shaped regions by repetition. The most practical shape to choose is a square, which can be used to construct both square and rectangular regions. To measure regions of other shapes, we first transform them into rectangles and then measure the resultant rectangles with the unit squares.

Children should develop the iterative process for measuring areas by covering square and rectangular regions with small square tiles and counting the number of tiles used as the measure. Later, the use of graph paper or a transparent grid may help speed this process. When this has been mastered, then parallelograms, trapezoids, and triangles may be measured by transforming them into equivalent rectangles.

The iterative process for measuring volume follows the same pattern as the process

for area. Small cubes are chosen for unit volumes, and these may be used to construct rectangular solids. Irregular volumes are transformed into rectangular volumes before measuring.

To measure mass (weight), a small unit mass must first be chosen. Identical copies of that unit are added to the balance pan until the mass being measured is matched. The number of unit masses used is then counted, and the resulting number becomes the measure of the mass. For classroom use, paper clips make practical small-unit masses.

8. *Measure between limits.* Unless the unit has been chosen with respect to the particular object being measured, it is generally not possible to construct congruent lengths, areas, or volumes by a simple repetitive process. When measuring the length of a pencil, for example, a child may find that five units form a length shorter than the pencil, while six units form a length longer than the pencil. Children should then report the measure of the length as between 5 and 6 units, or  $5 < m < 6$  (where  $m$  is the measure).

An arithmetic of measure limits can be developed. If the measure of the length of a piece of chalk is between 3 and 4 units, then the measure of the length of the pencil and the chalk end to end is between  $5 < 3$  and  $6 < 4$ . In a similar manner, the length of two pieces of chalk is between  $2 < 3$  and  $2 < 4$ .

9. *Subdivision of units.* When children check the arithmetic of measure limits by measuring the combined lengths directly, they usually find that the interval between the limits of the actual measure is less than the interval between the limits given by the arithmetic. Thus, although the arithmetic gives the measure limits for the length of two pieces of chalk as 6 and 8, actual measurement of the length of two pieces of chalk laid end to end may give limits of 7 and 8. This happens, of course, when the length of the original piece of chalk is much closer to 4 than to 3.



The difficulty that is raised here usually suggests to children that the interval between measurement limits should be made as small as possible. There are two ways to accomplish this—either choose a smaller unit of measure, or subdivide the unit of measure into smaller pieces. If one chooses a smaller unit, the interval between the measure becomes smaller, but the counting process becomes more difficult, since there are more copies of the unit to count. By subdividing a larger unit, we make both aspects easier. Counting is easier, since we have fewer larger units to count. The intervals between measure limits is smaller—after the last whole unit, we can switch to the smaller subdivided unit.

Children should subdivide basic units in any manner they wish and practice measuring with the new subdivided units of length, area, volume, and mass (weight).

10. *Calculate with measurements.* The best way to subdivide measurement units depends on how they are to be used. We can often shorten the counting process by doing simple calculations on basic measurements. For example, suppose we want to measure the area of a rectangle. We can cover it with unit squares and then count. Or we can count the number of squares

along the length of the rectangle and the number of squares along the width of the rectangle and multiply these numbers together to obtain the total count. In similar fashion, multiplying the length, width, and height of a rectangular solid is a shortcut for counting stacks of unit cubes.

The algorithms for calculations depend on the place-value system used in our notations. To keep our calculations simple, the subdivision of units should parallel our place-value system. Since we have a decimal system of notation based on powers of 10, it follows that for ease of calculation, the subdivision of the unit should also be based on powers of 10. *This is exactly what the metric system does, and this is the point at which the metric system becomes advantageous.*

Other subdivisions may be useful in other applications. It is often useful to consider halves or thirds of units, particularly in estimations, but no other subdivision procedure is as useful for computation as the decimal divisions used in the metric system. As teachers of young children, we must look ahead for the system that will ultimately be most useful to them and use that system from the time standard units are first introduced. That is why it is important to think metric—now!

## Thinking about measurement

LESLIE P. STEFFE

*As an associate professor of mathematics education at the University of Georgia, Athens, Georgia, Leslie Steffe is actively engaged in research dealing with children's thinking in mathematics. He recently acted as co-director of a conference on research of the Piaget type. In this article he suggests several ideas based on findings from such research.*

It is essential that teachers of mathematics have a good grasp of the thinking basic to the mathematical content they present to their students. When confronted with the general area of thinking, mathematics educators (including teachers) have traditionally turned to psychology for help. Some mathematics educators are currently turning toward theories of cognitive development in their quest to understand thinking basic to mathematics. The search is rich in content and rewarding in terms of implications for mathematics teaching. The implications are not necessarily in terms of pedagogical polemics but lie in the insight that teachers can gain into the thinking of the young child and the origins of that thinking.

Piaget's theory of cognitive development is a theory of intelligence. One of its fea-

tures is that it describes structures of thought and changes such structures undergo as a child changes in chronological age. Major stages of development of these structures have been identified by Piaget. Crucial ages at which changes in structures occur have been isolated at approximately eighteen months of age, seven years of age, and twelve years of age. Stages may be identified in terms of the age intervals: from birth to eighteen months of age, eighteen months to seven years of age, seven years of age to twelve years of age, and twelve years onwards. Two stages are particularly of concern in this paper—the stage from eighteen months to seven years, called the stage of preoperational representation; and the stage from seven years to twelve years, called the stage of concrete operations. In the case of individual

children, exceptions in when stages occur have been noticed, but not in the sequence of occurrence.

In the theory, overt action is viewed as a source from which intelligence originates. As the child grows older, the overt actions are internalized (they occur in the mind) and become operations of thought, or, for short, operations. Such operations of thought are viewed as having structure. Concrete operations are called *concrete* to denote that children can think in a logically coherent manner about objects that exist and about actions that are possible. Children can perform concrete operations, however, in the immediate *absence* of objects. Some examples of concrete operations are classification, ordering, counting, and the fundamental operations of the logic of classes and relations. In what follows, the operation of ordering is discussed.

A child can perform an overt act of comparing two strings (say  $A$  and  $B$ ) to ascertain if  $A$  is as long as  $B$ , if  $A$  is shorter than  $B$ , or if  $A$  is longer than  $B$ . In order to explain, even partially, the conditions that have to hold for such overt acts to represent operations of thought, it is necessary to consider a child placed in a situation where he is asked to order a bundle of strings from longest to shortest (assume the strings are all of different lengths). To avoid the possibility of the child performing the ordering by just looking at the strings, the strings have to be close enough in length so that any two strings are not obviously of different lengths. That is, to find the relation that holds, a child actually has to compare the strings by placing one end point from each string adjacent to another and comparing the two remaining end points with the strings drawn taut (see fig. 1). To perform the ordering task, the child must take two strings, say  $A$  and  $B$ , and overtly compare

---  $A$   
 $B$

Fig. 1

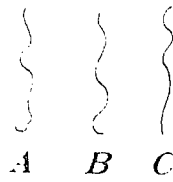

$A$  longer than  $B$

$B$  longer than  $C$

Fig. 2

them. Suppose he finds that  $A$  is longer than  $B$ . He then must take a third string and compare it with either  $A$  or  $B$ . Imagine that he compares it with  $B$  and finds that  $B$  is longer than  $C$  (see fig. 2). At this point, if the overt action represents operations, there is no necessity for the child to overtly compare  $A$  and  $C$ . He is able, in his mind, to compare  $A$  and  $C$  on the basis of the premises that  $A$  is longer than  $B$  and  $B$  is longer than  $C$ . That is, the child is able to compose the two relations " $A$  longer than  $B$ " and " $B$  longer than  $C$ " and infer that  $A$  is longer than  $C$ , which is one central aspect of the operation of ordering. In mathematics, it is what is known as the principle of transitivity. Although not unequivocal, some research (Smedslund 1963) shows that the average age at which children acquire transitivity of length relations lies somewhere between seven and eight years.

Imagine now that when the child compared string  $C$  with string  $B$  he found, instead of  $B$  longer than  $C$ ,  $B$  shorter than  $C$  (see fig. 3). In this case, if the overt actions represent operations, there is no necessity for the child to make any further overt comparisons to ascertain that  $B$  is shorter than  $A$  or that  $C$  is longer than  $B$ . He is able, in his mind, to construct a converse relation. When the child thinks, " $B$  is shorter than  $C$ ," it is a relation that has a directionality from  $B$  to  $C$ . The converse relation, " $C$  longer than  $B$ ," has a direc-



$A$  longer than  $B$

$B$  shorter than  $C$

Fig. 3

tionality from  $C$  to  $B$ . In other words, the child starts with  $B$ , proceeds to  $C$  ( $B$  shorter than  $C$ ), then back to  $B$  ( $C$  longer than  $B$ ). Such an expression of reversibility is essential in the structure of the operations.

In the case of figure 3, the child cannot establish, in thought, any logical relation between  $A$  and  $C$  by the comparison of  $B$  and  $C$  and  $A$  and  $B$ . It is essential for him to overtly compare  $A$  and  $C$  to complete the seriation (ordering) of  $A$ ,  $B$ , and  $C$ . Assume that the child found  $A$  longer than  $C$ , so the order of the strings is as in figure 4. The child must now take another string, say  $D$ . Imagine he finds that  $B$  is longer than  $D$  with one overt comparison. The concrete-operational child would not have to overtly compare  $A$  with  $D$  nor  $C$  with  $D$  to infer the correct relations. For example, to infer that  $A$  is longer than  $D$ , he could take at least two different routes to establish the relation. First, because he knows that  $A$  is longer than  $B$  and  $B$  is longer than  $D$ , he knows that  $A$  is longer than  $D$ ; or, second, because he knows that  $A$  is longer than  $C$  and  $C$  is longer than  $D$ , he can infer that  $A$  is longer than  $D$ . A most efficient strategy on the part of the child would be to reason that  $B$  is shorter than both  $A$  and  $C$ ,  $D$  is shorter than  $B$ , so  $D$  is shorter than both  $A$  and  $C$ . Children in the stage of preoperational representation do not exemplify such flexibility of thinking.

Other structural characteristics of concrete-operational thought exist, but they are better brought out in other contexts. The above characteristics of transitivity and reversibility discussed in the context of a seriation-of-strings task are quite general and apply to other order relations; that is,

"less than" and "more than" for numbers. One point should be made explicit. That is, it is not necessarily true that all children who are eight years of age are in the stage of concrete operations, nor is it necessarily true that all children who are six years of age are not in the stage of concrete operations. It is important to note that children are not, in the present curriculum, taught directly to think in the ways characterized. They do so without formal instruction.

Now, consider a child who is placed in a situation where he is asked to categorize a collection of "linear" objects (sticks, strings, pipe cleaners, etc.) into subcollections, where the subcollections are formed by using the relation "as long as." That is, any object in a given subcollection is as long as any other object in that subcollection, and any two objects taken from different subcollections are of different lengths. Some structural aspects of concrete operations noted earlier are involved, as well as others. The child can start by selecting an object, say  $A$ , and finding another, say  $B$ , so that  $A$  is as long as  $B$ . The child may now find another object, say  $C$ , as long as  $A$ . If these overt actions represent operations, there is no necessity for the child to overtly compare  $B$  and  $C$ . He is able, in thought, to compare  $A$  and  $C$  on the premises that  $A$  is as long as  $B$  and  $A$  is as long as  $C$ . For the concrete-operational child, knowing that  $A$  is as long as  $B$  also implies that the child knows that  $B$  is as long as  $A$  (reversibility), and knowing that  $B$  is as long as  $A$  and  $A$  is as long as  $C$  implies that the child is able to infer that  $B$  is as long as  $C$  (transitivity). Given that the child views  $A$ ,  $B$ , and  $C$  as all being as long as one another, he can freely use any one of the three as representative of the others, or, in other words, use the principle of substitution. Moreover, the child can compose relations as follows. If he finds an object  $D$  such that  $D$  is not as long as  $C$ , he knows that  $D$  is not as long as either  $A$  or  $B$  without overt comparisons because  $A$  is as long as  $C$  and  $B$  is as long as  $C$ .

The above principles of thought at the

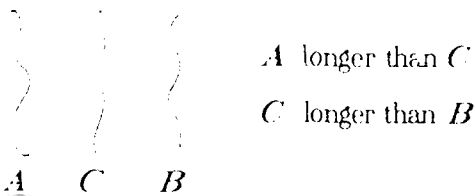

Fig. 4

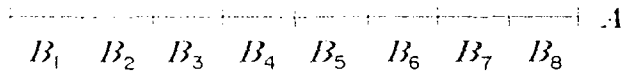

Fig. 5

stage of concrete operations are necessary in classifying "linear" objects into subcollections on the basis of "as long as." How such thinking is involved in measurement tasks follows.

Measurement is a process whereby a *number* is assigned to some object. Consider, for example, a line segment  $A$  as an object to be measured (a taut piece of string is a physical representation of a line segment) and another segment  $B$  usually considered as a unit of measurement, selected to measure the segment  $A$ . To measure  $A$ ,  $B$  is laid alongside  $A$  and iterated as many times as necessary. Consider the special case in figure 5, where  $A$  is eight units in length. The child must conceive of  $A$  as being partitioned into eight subparts, determined by the iteration of  $B$ , each of which is as long as  $B$ ; that is,  $B_1$  is as long as  $B$ ,  $B_2$  is as long as  $B$ , and so on. Obviously, the child *must* conceive, in thought, that  $B_1$  is as long as  $B_2$ . Since there is no possibility of directly comparing  $B_1$  and  $B_2$ . The same holds for any two of the subparts. Too, the child must conceive that  $B_1$  is shorter than  $B_1 + B_2$  ( $B_1 + B_2$  means the segment formed by  $B_1$  and  $B_2$ ),  $B_1 + B_2$  is shorter than  $B_1 + B_2 + B_2$ , and so on; and at the same time he must conceive that  $B_1 + B_2$  is longer than  $B_1$ ,  $B_1 + B_2 + B_2$  is longer than  $B_1 + B_2$ , and so on. Or, in other words, a stick one unit long is shorter than a stick two units long; a stick two units long is shorter than a stick three units long; and at the same time, a stick two units long is longer than a stick one unit long; a stick three units long is

longer than a stick two units long; and so on.

Too often measurement is begun in the elementary school by taking a foot ruler, marked off into units of an inch or fractional parts thereof, and applying it to objects to be measured, obtaining answers such as "the book is eleven inches long" (assuming a book was to be measured). Children certainly like to measure objects. However, if they have made their *own* measuring instruments, two children may well find "different" answers for how long the book is. The resolution of such a *conflict* may lead to a quite powerful notion—a unit of measure for each child that is as long as the unit of measure for any other child. In the resolution of such conflicts, other structural characteristics of concrete operations become immediately apparent. For example, consider a simple situation such as that depicted in figure 6. Segment  $A$  (for example, the length of the book) is measured by two rulers, ruler 1 and ruler 2. With ruler 1, segment  $A$  is found to be twelve units long, and with ruler 2, eight units long. How can the same segment have two "different" lengths? It is essential at this point that a child be able to simultaneously conceive that the unit of ruler 1 is shorter than the unit of ruler 2 and that there are more subsegments of ruler 1 than there are of ruler 2. For a child in the stage of preoperational representation, Piaget's theory would predict that he is not able to conceive simultaneously of both relations. A child at the stage of concrete operations, however, could establish both relations and

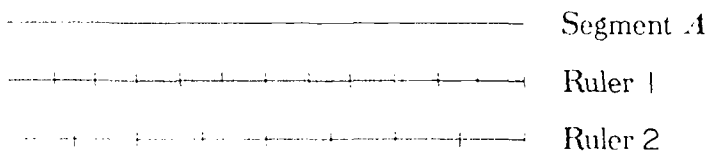

Fig. 6

coordinate them; thereby it would seem that such a child would have a more powerful conceptualizing ability than the pre-operational child as regards construction of standard units of measurement.

To illustrate more lucidly the point concerning the construction of a standard unit of measurement, consider the three situations depicted in figure 7. In each situation, a child is asked if he can make a length comparison of the two polygonal paths. (A polygonal path may be thought of as a set of segments connected at the end points.) The paths are not movable so that the child cannot make a direct, overt comparison between them. First he must ascertain whether the subsegments of each path are of the same length. The child could do this by selecting a stick (a unit) as long as one subsegment and then comparing it with each such subsegment in that path, as already discussed relative to figure 5. He must, by necessity, be able to use transitivity and reversibility in order to conceive of, say, path 1 of situation 1 as being partitioned into subsegments all of the same length. Note that in path 2 of situation 3 one subsegment is shorter than the unit and one is longer, so that no comparison is possible, on a logical basis, of path 1 and path 2. Of course, more sophisticated means are available to make the comparison.

In situation 1, all subsegments of path 1 are of the same length and all subsegments of path 2 are the same length. It is

necessary for a child to compare one subsegment of path 1 with one subsegment of path 2 through the use of an external stick (thus employing transitivity and reversibility) to ascertain that they are of the same length. Then by establishing that one subsegment of path 1 is as long as one subsegment of path 2, the principle of substitution must be employed to ascertain that any subsegment of path 1 is as long as *any* subsegment of path 2. Now, in order to compare the lengths of the paths, the child must either construct a one-to-one mapping between the subsegments of each path or else count them. In each event, the conclusion, path 2 is longer than path 1, is based on the premises that there are more subsegments in path 2 than in path 1 *and* that each subsegment of path 2 is as long as each subsegment of path 1.

Although in situation 1 it is not necessary for the child to establish and coordinate both relations in order to reach a correct conclusion, in situation 2 it is. In situation 2, each subsegment of path 1 is as long as any other subsegment of path 1 but longer than any subsegment of path 2, all of which are of the same length. The two premises on which a child must base any logical conclusion are: there are more subsegments in path 2 than in path 1, *and* each subsegment of path 1 is longer than each subsegment in path 2. Considering just these two premises, the child must perceive that it is not possible to compare the lengths of path 1 and path 2. In figure

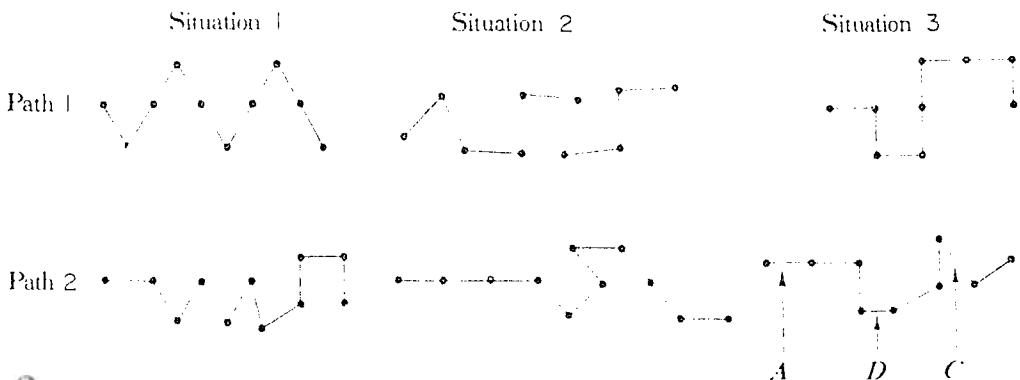

Fig. 7

6, a similar situation exists. There, however, the polygonal paths forming the rulers are *segments* that are proximal to each other and to segment  $A$ , so that visual comparisons are possible. No conclusions about the relative lengths of the two rulers could be ascertained from the two premises that the unit of ruler 2 is longer than the unit of ruler 1 and there are more subsegments of ruler 1 than of ruler 2. Those two relations considered simultaneously were used to *explain* why two rulers, for which it was *given* that they were of the same length, could have different numbers as lengths. In situations 1, 2, and 3 of figure 7, the task is to compare the lengths of path 1 and path 2 (which are not movable) based on knowledge of the lengths of the subsegments and how many such subsegments form the paths. In situation 1 such a comparison is possible. In situations 2 and 3 such a comparison is not possible. In situation 3, the reason a comparison is not possible is different from that in situation 2. In path 2 of situation 3, if a child selects a stick as long as a subsegment (say  $A$ ), he will find that there are exactly two subsegments ( $C$  and  $D$ ) not as long as the stick ( $C$  is longer than  $A$  and  $D$  is shorter than  $A$ ). If the child is at the stage of concrete operations, he should know that even though there are as many subsegments of path 1 as there are of path 2, he cannot compare the lengths of the two paths. It is essential that a child have the ability, before such situations are presented, to ascertain whether the

subsegments of any path are of the same length. It would also seem necessary that the abilities outlined above concerning situations 1, 2, and 3 of figure 7 be present before the number line is used as a model for operations with whole numbers.

Considering the above discussion, for a child to conceive a *need* for the construction of a standard unit of measurement it seems necessary that he be placed into situations that are resolvable but that involve conflict (fig. 6) or into situations that are not resolvable (situations 2 and 3 of fig. 7). Such situations must be carefully selected so that the thinking necessary for resolution (or nonresolution) is available to the child.

Once a class of children have constructed rulers with a standard unit of measurement (e.g., an inch), they should use the rulers to measure objects. In such usage, concepts of inner and outer measure become important in forming approximations to the length of objects that are not a whole number of units long. In figure 8, the inner measure of segment  $A$  is six units and the outer measure is seven units. The length of the segment is *between* six and seven units. The inner measure is the greatest number of units that are completely *included* in the segment, and the outer measure is the least number of units needed to completely include the segment. If the children agree to make two units out of each one in their ruler, then a closer approximation could be made to the length of segment  $A$  (see figure 9). In figure 9, seg-

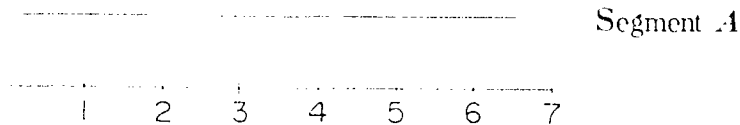

Fig. 8

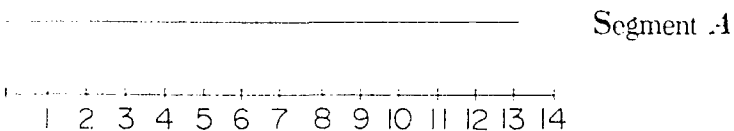

Fig. 9

ment  $A$  is between 13 and 14 units, or, in terms of the original unit, between 6½ and 7 units. It is necessary that the child feel no conflict in representing a length by two numbers in order to obtain successive approximations to the length of a segment, as was done with figures 8 and 9.

A fuller discussion of measurement per se would at least include English units of linear measurement, metric units of measurement, area measurement, volume measurement, and conversions from one measurement system to another (which includes a well-developed concept of equal ratios). Such, however, was not the intent of this paper. Rather, aspects of thinking foundational to measurement have been investigated. In that investigation it was found that principles of transitivity, reversibility, and substitution, as well as an ability to conceive of two relations simultaneously, were all foundational. Enough situations and examples have been included so that a teacher with a little ingenuity can assess such aspects of thinking in her classroom.

### Bibliography

- Biggs, I. F., and J. R. MacLean. *Freedom to Learn: An Active Learning Approach to Mathematics*. Ontario: Addison-Wesley Publishing Co., 1969.
- Ginsberg, N., and S. Opper. *Piaget's Theory of Intellectual Development: An Introduction*. Englewood Cliffs, N.J.: Prentice-Hall, 1969.
- Piaget, J. *The Psychology of Intelligence*. London: Routledge & Kegan Paul, 1964.
- Ripple, R. F., and V. N. Rockcastle, eds. *Piaget Rediscovered: A Report of the Conference on Cognitive Studies and Curriculum Development*. Ithaca, N.Y.: School of Education, Cornell University, 1964.
- Resskopf, M. F., I. P. Stelle, and S. F. Taback, eds. *Piagetian Cognitive Development Research and Mathematical Education*. Proceedings of a conference on Piaget-type research in mathematical education held at Teachers College, Columbia University, 1970, Washington, D.C.; National Council of Teachers of Mathematics and Teachers College, forthcoming.
- Smedslund, J. "Development of Concrete Transitivity of Length in Children." *Child Development* 34 (1963): 389-405.
- Van Engen, H. *Patterns in Arithmetic: A Course*. Developed by the Wisconsin Research and Development Center for Cognitive Learning. Available from the National Center for School and College Television, Bloomington, Indiana.
- Van Engen, H., M. Hartung, and J. Stoehl. *Foundations of Elementary School Arithmetic*. Atlanta: Scott, Foresman & Co., 1965.



# Teaching about “about”

HAROLD C. TRIMBLE

*A professor of education at Ohio State University,  
Harold Trimble describes himself as “a would-be teacher;  
‘would’ always; ‘be,’ as other duties permit.”*

To many adults mathematics is a mystery, an occult science beyond their powers of reason. To test this bald statement, talk to boys and girls of high school age and to adults. Listen to what they say. Observe what they do in simple problem situations that involve numbers. Notice how they try to “remember what to do” or begin to perform random calculations. Notice how few people wade into a problem confident of their own good sense.

Now consider a child who studies algorithms for addition, subtraction, multiplication, and division in grades three through six. Much of his time is spent learning to find “right” answers. Perhaps he concludes that mathematics is *the* place in the world where exact answers are available and required. At this point in his mathematical development, a child may encounter what seems to him to be a contradiction. He has become accustomed to using numbers to record measurements. And now the teacher tells him that all measurements are approximations; that, in the arithmetic of measurement, there are no exact answers, and, even worse, correct calculations do not necessarily produce “correct” answers.

This is, of course, only one of the critical moments in which a person may learn to believe that mathematics is a mystery. Perhaps it is an effective one for many children. At least it would appear to present a fine opportunity for a child to lose his intellectual self-confidence.

There are, of course, two ways to try to correct such a misunderstanding. You can provide corrective experiences just prior to the critical moment. Or, you can take a longer look to discover how the misunderstanding was built into the curriculum over the years preceding the critical moment.

Let’s look first for a short-range solution. As a teacher you may not be in a position to rewrite the program of study. Often the best you can do is patch up mistakes that previous teachers have made.

Have you seen the advertisement in which one razor blade corrodes more quickly than another one? The edge of a razor blade appears to the eye as a line segment. What could be more perfect than the edge of a blade used only a few times? Yet, under a microscope the edge becomes a mountain range! A teacher can use pictures like these to dramatize the

contrast of the perfection of mathematics with the imperfection of reality. Then he may be able to get children to see how calculations, correct in the mathematical world, fail to reflect the rough edges of the physical world.

My own lack of confidence in talking to students, even in using pictures to dramatize the contrast of the mathematical model with the everyday reality, is based on experience. My efforts along these lines have failed. Because of this, I am convinced that boys and girls need to use a correct mathematical model for a while before they can appreciate and understand the incorrect, but good-enough-for-practical-purposes, model now presented in most school mathematics programs. So, to my mind, even the short-range solution requires more than showmanship.

I propose, then, providing children with experiences in which they contrast the *mathematical idea* of measure (a real number, length of a line segment, weight, or the like) with the *physical idea* of measurement (the process in the real world). A child readily accepts a thing as what it is. It has something that grownups call a measure. This may be a length, a weight, a time, or another idea-level property. The trouble is that real lengths don't fit rulers perfectly. The measure is an idea. It is what it is. The problem is to express the measure using numbers on a scale. This is the basic problem of measurement. Carpenters are content to call a measure  $12\frac{1}{2}$ . Machinists might call it 12.49. They mean *about*, and about means good-enough-for-the-purposes-at-hand. That is why walls have floor moldings—to heal the difference between the lengths of wall boards and the heights of rooms. But *about* is not a good mathematical word. Sometimes we agree that "about  $12\frac{1}{2}$ " means  $12\frac{1}{2} \pm \frac{1}{4}$ ; but a better way to say this is to speak of a measure  $m$ , about which we know that  $12\frac{1}{4} < m < 12\frac{3}{4}$ . At least I like it better because it keeps things straight. There is a theoretical thing called a measure,  $m$ . But the process of measurement is a process of

comparison that inevitably leads to making an approximation. So the best we can know about  $m$  is that it belongs to an interval. For example, we may know that

$$12\frac{1}{4} < m < 12\frac{3}{4},$$

or we may know that

$$12.485 < m < 12.495.$$

What we know will depend on such practical questions as the type of measuring tools we use.

In present-day programs in arithmetic, children begin the study of measurement by measuring things that come out as whole numbers, such as 2 or 3 or 5. This seems wrong to me. It would be much better, I think, to begin with things between 2 and 3, or between 5 and 6. If early experiences with measurement have implanted the idea that things really do have measures like 2 or 3 or 5, children especially need to work with the *between* idea as they begin to perform calculations in the arithmetic of measurement.

A good problem to get fifth or sixth graders started is to ask How far above the first floor of the school is the second floor of the school? There are, of course, a lot of ways to measure this. Fine. Suppose one child, or committee of children, drops a weighted string down the stairwell and uses a yardstick to measure the length of the string. Suppose another child, or committee, measures the rise for one step, multiplies by the number of steps, and comes up with an answer. The answers are different. Who is right?

In a context like this one, it will be easy to convince fifth graders that a stairstep has a riser of some definite height, but it is not possible to say exactly what this height is. The best one can do is to make a statement like: The height is  $h$ , where

$$7\frac{1}{4} < h < 7\frac{3}{4}.$$

For sixteen steps like this one, the height is  $H$ , where

$$16 \times 7\frac{1}{4} < H < 16 \times 7\frac{3}{4}.$$

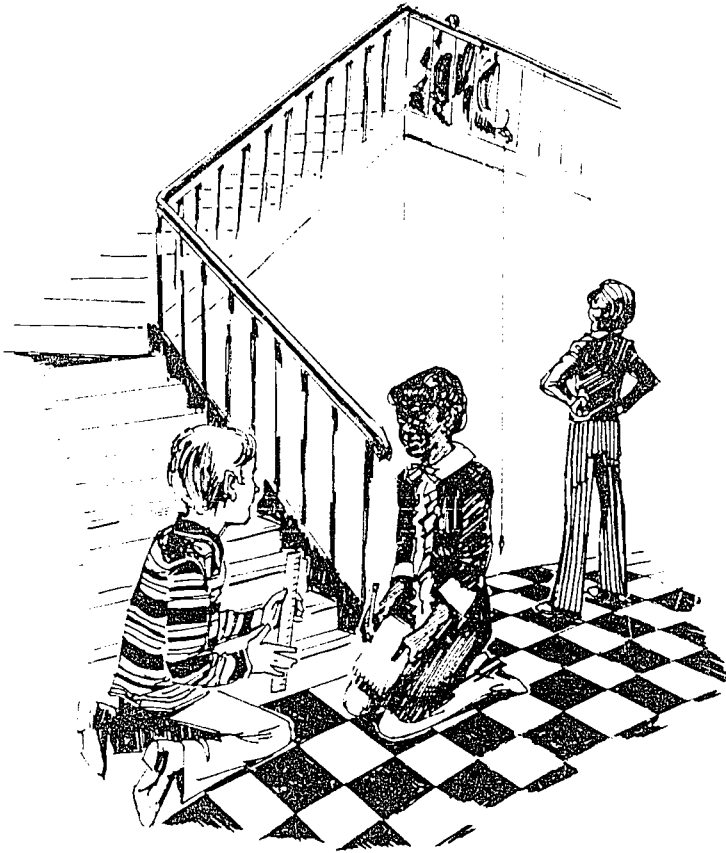

Notice that the calculation required is doubled when you work with intervals. Notice that  $16 \times 7\frac{1}{4} = 116$  and  $16 \times 7\frac{3}{8} = 118$ , so that an interval  $\frac{1}{8}$  inch long ( $7\frac{1}{4}$  to  $7\frac{3}{8}$ ) becomes an interval 2 inches long (116 to 118) when you multiply it by 16. I believe that it is in contexts such as this one that the absolute errors and relative errors of the arithmetic of measurement can be made sensible to children.

What I am proposing, then, is involving the children in a few problems in which they perform simple measurements; leading them to notice that different methods or different observers may get different results; having them express the measures using intervals; helping them perform calculations with intervals for a time before trying to teach the more conventional approach to the arithmetic of measurement—rounding of answers.

The next example may be more suitable for junior-high age children. When a boy runs up a flight to stairs, he does work. If he climbs  $h$  feet and weighs  $w$  pounds, he does  $hw$  foot pounds of work. If this takes  $t$  seconds, his power is expressed as

$$\frac{hw}{t} \text{ foot pounds per second.}$$

Since 1 horse power is 550 foot pounds per second, we can write

$$P = \frac{hw}{550t} \text{ horse power.}$$

You can have children measure their horse powers using this formula. They must measure  $h$  in feet and, for each child,  $w$  in pounds, and  $t$  in seconds. To get a usable measure of  $t$ , a stop watch will be needed. Again, it will be easy to get arguments going about whether or not Joe is really more powerful than Sam. Again, intervals will be needed to allow for the inaccuracies



of measurement. For example, the children might agree that

$$11\frac{1}{2} < h < 11\frac{3}{4} \quad (\text{Between 11 ft. 8 in. and 11 ft. 9 in.},$$

$$111\frac{1}{2} < w < 112\frac{1}{2} \quad (\text{Weight of one boy to the nearest pound),}$$

$$\text{and } 2\frac{1}{4} < t < 2\frac{3}{4} \quad (\text{Time for the same boy allowing an error of } \frac{1}{4} \text{ second either way).}$$

Notice that

$$\left(11\frac{1}{2}\right) \times \left(111\frac{1}{2}\right) < P < \left(11\frac{3}{4}\right) \times \left(112\frac{1}{2}\right)$$

$$\left(550\right) \times \left(2\frac{1}{4}\right)$$

There are opportunities for computational practice. The more students who compete, the more practice. Important mathematical ideas are also involved. For example, the smaller the divisor, the greater the quotient.

Between the two examples given, there are, of course, many of intermediate difficulty. The idea is not to teach physics, or

surveying. It is, rather, to work with intervals in order to develop some appreciation of the effect on the answer of approximate data. With such a background, it may be possible to get children to understand and appreciate the arithmetic of measurement as a shorter way to find answers "good enough for practical purposes." Working with approximations and rounding answers is not really mathematics, it is a practical way to shorten calculations with intervals.

You may want to think about the longer-range solution. If you buy the idea that the correct mathematical model for calculations with measurements is calculations with intervals, you may wish to:

1. Plan the first experiences with measurement to fit the realities of the situation. Have children measure—and record the

answer in the form  $3 < m < 4$ , rather than say "the length is 3."

2. Use the students natural desire for greater precision to motivate the use of smaller units of measure, and, later, of common fractions and decimal fractions.
3. Lead up very gradually to the idea of a real number as a limit defined by a set of nested intervals. For example, the number  $\pi$  has been a source of great confusion. However, children accustomed to recording a measure as an interval should not find a set of intervals like the ones that follow surprising.

$$3 < \pi < 4$$

$$3.1 < \pi < 3.2$$

$$3.14 < \pi < 3.15$$

⋮

The number  $\pi$  is the measure defined by the ratio of the circumference to the diameter of a circle. It can be approximated by intervals obtained by measurement and, later in the study of mathematics, by intervals obtained by theoretical methods.

4. Use the arithmetic of intervals as background for the idea of a vector space.

In this instance, notice that when you measure with an agreed-upon unit (hundredths of inches, for example) and record  $a, b, \dots$  in terms of that unit, then for measures  $m_1$  and  $m_2$ , defined by  $a < m_1 < b$  and  $c < m_2 < d$ ,

a)  $m_1 = m_2$  if and only if  $a = c$  and  $b = d$ , and

b)  $m_1 + m_2$  is defined by  $a + c < m_1 + m_2 < b + d$ .

c) For an integer  $n$ ,  $nm_1$  is defined by  $na < nm_1 < nb$ .

So this arithmetic of intervals is remarkably like vector arithmetic. It has the additional, rather unique, property that

d)  $m_1 m_2$  is defined by  $ac < m_1 m_2 < bd$ .

Whether you seek a short-range or a long-range solution for the problem of making sense out of the arithmetic of measurement, I have argued that it will help to view a measure as an unknown element of an interval. I have suggested asking boys and girls to perform calculations with intervals. I have pointed out several advantages of such calculations. But, mainly, I claim that intervals provide a mathematical model for the arithmetic of measurement that contrasts with the rather sloppy, this-works-even-though-it-isn't-really-right rubrics with which we currently mystify children.

*Metrication, Measure, and Mathematics*

# Metrication, Measure, and Mathematics

ALAN R. OSBORNE

The United States has achieved an enviable industrial technology. The interchangeability of parts, standardization of assembly-line procedures, planned obsolescence, commonality of marketing practices, and the efficiency of management that characterizes our industry have solidified a remarkable number of traditions as shown in Daniel Boorstin's *The Americans: The Democratic Experience* (1973). The pervasive orientation to mass production and uniform consumerism has established measurement as a critical component of American industry. The measurement units and procedures are an essential tradition of the mass-production, assembly-line techniques that characterize our technological, industrial society.

But this measure tradition has created an extensive problem for trade and, ultimately, our position of leadership in the industrial and commercial world. The rest of the world is metric. The economy of the United States is dependent on trade for our continued health; it affects each of us. The sellers of goods manufactured in the United States are finding markets closed. Just a few years ago the benefits of expanded world trade did not outweigh the bother and the expense of converting to the metric system. Now it is necessary for the United States to shift from the traditional, comfortable English system to the metric system in order to enjoy the benefits of continued and increased commerce in manufactured goods with the remainder of the world. This is recognized and accepted by leaders in government and industry

(U.S. Congress Senate Bill 100), and the country is in the process of making the shift to the metric system.

As conversion is instituted, the country and individuals face new problems and added expense. The comfortable intuitions and effective estimations that are part of every adult's way of life will not apply. The wrenches and other equipment in the workman's tool box will have to be replaced. In the same way, industry will need to retool with considerable inconvenience and expense. Measures in the comfortable English system will become anachronisms—useful perhaps as literary referents of symbolic value—but this is an adult problem and not the problem of a child who will finish school and move into a metric world. The child should not be bound by the intuitions and traditions of heritage that adults possess.

The task of this paper is to consider implications of the conversion to the metric system for the schools. As such, it will not argue the efficacy of the conversion; this is well documented and discussed elsewhere (in publications such as De Simone's *A Metric America: A Decision Whose Time Has Come*, 1971). The advantages are clear. It behooves the schools not to make a big fuss about conversion but rather to treat it simply as the down-to-earth act of reasonable, intelligent people. Otherwise, we run the profound risk of helping children anticipate nonexistent difficulties in handling concepts and processes of metric measurement within the metric system. This is not to say that there are no difficulties

in the teaching and learning of measurement. Rather, the difficulties are not attributable to the conversion to and use of the metric system. Indeed, measure concepts do provide major difficulty for teachers and for children. The fact that most beginning physics courses at the college level devote extensive amounts of time to the teaching of measurement is testimony to difficulty in establishing measure with children. This is to say that considerable attention need be given to considering the problems of teaching measurement in the schools. Given the fact that conversion to the metric system will entail modifying curricular content, we submit that the time is opportune for us to address basic problems of improving the teaching of measurement. If the content and measurement activities and curricular design must be in terms of a different system of measurement, should we not also modify the nature of the pedagogical design to treat difficulties in learning measurement?

The move to the metric system provides three different but not unrelated opportunities to modify the curricular and pedagogical design of teaching measure. Each of these will be discussed here in terms of suggesting important characteristics of measurement that need to be established with children and highlighting some problems and unanswered questions about learning measurement. First, the nature of measurement in the mathematical sense will be contrasted with the nature of measurement in the scientific sense. Second, the psychology of measure learning will be discussed. Finally, the problems and procedures of establishing a metric intuition will be considered.

### **The nature of measure**

A student teacher in an eighth-grade mathematics class faced the task of planning lessons about measurement for his class. He looked at the pages of the text, which contained such words as "relative error," and "accuracy." Turning to his supervising teacher and displaying dismay,

he stated, "I thought I was going to teach mathematics. This looks like physics. I chose not to major in physics because I liked mathematics best. Now what is this business of teaching science? Shouldn't this be the responsibility of the science teachers? It certainly is in the science texts and curriculum." The supervising teacher hesitated and said, "I have often thought the same. I teach measurement because it provides a lot of opportunity to provide children practice with fractions—converting between English units is a good, relevant context for drill in multiplication and division. I also notice that my children have trouble with measurement, and they will need these skills later on in life."

There is an element of truth in the remarks of both the student teacher and his supervisor. Measurement is a scientific process and skill. Children do need these processes and skills. Premetric curricula can be rationalized in terms of a relevant context for drill in handling fractions in conversion between units, but analysis of measurement with a broader perspective indicates a much larger potential than in either of these points of view. First, measurement does provide one of the best environments for establishing the concept of a mathematical model, one of the premiere and most productive concepts of modern mathematics. Second, the processes of measurement are firmly based on the concept of function. A functional approach opens vistas of power in using the measure processes.

### **What is measure?**

Teachers of mathematics are often confused about the goals and objectives of teaching measure concepts and skills. The confusion stems partly from not possessing a clear conception of the distinctions between measure in science and measure in mathematics. Lacking a clear perception of the differences and distinctions, teachers find it difficult to design productive instructional materials and to plan effective teaching strategies. The difficulties for



learners stem from the ambiguities arising from the common words and parallel processes used by scientists and mathematicians in describing and talking of different concepts and goals.

The scientist has a different goal in using measure than the mathematician. He is attempting to describe reality carefully and precisely in order to predict future events—he is building a model of reality. This may be illustrated as follows:

Model

Reality

The model is a system of concepts and propositions representing reality. Conflicts within the system predict how reality will behave. The soundness and usefulness of the model as a description of reality is determined by the correctness of the predictions.

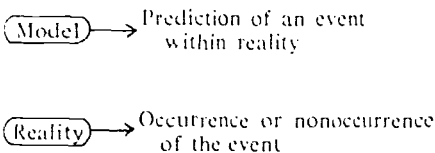

If the predicted event takes place, then the model "fits" reality and has a degree of soundness and usefulness. If it does not occur, then the model does not "fit."

The building of models depends on many inductive and observational processes. The matching of the model to reality is strengthened if a mathematical matching can be achieved. This means providing a foundation of measurement—a quantification of quantities and phenomena—for a base of comparison for the model. One critical process in assuring a good fit of the model into reality is the scientist's measurement process. It necessarily depends on and involves observation and is, consequently, subject to error.

Suppose, for example, a scientist desires to build a predictive model for the expansion of a metal rod,  $AB$ , as a function of change in temperature. Verifying the predictive rule (a part of the model) depends on accurately ascertaining the length of the rod under two different conditions of temperature. (See fig. 1.) The scientist must place a ruler such that a point of the ruler falls on point  $A$ . This requires judgment and may introduce error into the system. The scientist then observes where point  $B$  falls on the scale. If he observes that  $B$  falls between 8 cm and 9 cm, he must decide which is closer to point  $B$ . Again judgment, and, necessarily, error is introduced into the system, and this process must be repeated for the other temperature condition. The scientist may improve his judgment by using a more finely graduated scale or by introducing some other observational techniques that refine his judgment. He then applies the rules of the mathematical system to the model and establishes his predictive rule. The reasoning may involve mathematical observations, such as multiplication and addition, that have the potential for magnifying the effect of errors in the observational process.

Error in scientific process or in the use of models can be made in another manner—perhaps the internal structure of the model has flaws; the reasoning may not be valid or may lead to inconsistencies; inappropriate rules may introduce systematic errors leading to useless rules that do not predict the event accurately when the scientist verifies the rule. Correctness within the reasoning of the model is the concern of the mathematician. He operates within the model by providing the syntactical rules that govern the appropriateness of operations and the relations between operations within the system. Indeed, for the mathematician the model assumes a reality of its own, and he may not even care whether there is a corresponding reality. He is concerned only with internal consistency, validity of the reasoning, and whether solutions exist for problems within

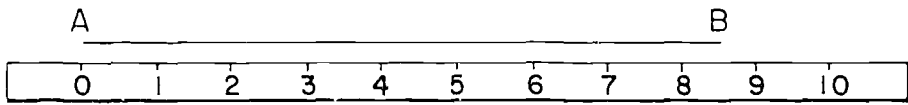

Fig. 1

the model. The scientist is concerned with whether or not the system will fit into reality. Carl Allendoerfer's article for parents—"The Nature of Mathematics" (1965)—provides a straightforward analysis of the types of thinking that are used in building mathematical models.

Most people do not operate as either just the mathematician or just the scientist—our world of mathematics and science is not so idealized. We do not typically concern ourselves with building an accurate "fit" of a model into reality with mathematics. Rather, we take previously developed, intact, systems or models and use them. The measure concepts and operations within Euclidean plane geometry are an example of such an intact system. Consequently, we are concerned with both establishing measurement as a series of observational processes and using measure within the intact model.

The child needs to consider measure from the standpoint of both the intact system and the observational processes. He needs to deal with, accept, and incorporate the intact system so that he may work within the world of future mathematical learnings. He needs the observational processes in order to learn future scientific concepts and because this is the sort of measure that he will find most practical in his adult life as "the man on the street." But these processes and intact systems also provide the child with some of the skills and understandings necessary for coping with measure today as well as in future adult life. The child needs measure to quantify his world, to make mathematical as well as verbal descriptions of his environment. Measure and measurement concepts give the child the means of describing the world about him.

### Length

The example of a scientist determining the length of a rod was fraught with observational difficulties. These could not be evaded and required judgment on the part of the scientist. Necessarily, error and inexactitude were involved. Length in the model system or in mathematics is not subject to observational difficulties; it is exact. Corresponding to a pair of points  $A$  and  $B$  is a *single* real number that is called the distance from  $A$  to  $B$ . That is to say, distance is a function that maps segments of a line into the set of real numbers.

The distance function may be defined or characterized several different ways depending on the particular axiomatic structure used to describe geometry. The classical axiomatization of Euclid, the structure for the usual Cartesian coordinate system, and the intermediate coordinatization exemplified by SMSG's grade-ten geometry course each provide variations of the defining characteristics of the distance function and the restrictions to which it is subject. Usually, the axiomatic structure of geometry in elementary and junior high school mathematics texts is implicit rather than explicit. Rather than being concerned with the niceties of the restrictions imposed on the function by the axiomatic structure, authors emphasize the characteristics of the distance function that hold for each of the implicit axiomatic structures. These common characteristics are precisely the "big" ideas that a student needs for future encounters with more formal treatment of length. They provide the organization of his cognitive structure that assures readiness and receptivity for new concepts.

Let us examine the distance function with the intent of identifying some of these

important characteristics. In the manner of the writers of elementary and junior high school texts, we will not provide an explicit description of the axiomatic structure of geometry. Rather, the distance concepts spelled out below hold in any Euclidean context. The intent is not to produce a minimal, independent, descriptive set of statements but to identify a sufficiently comprehensive set of primitive length concepts to allow the student the power to deal with most situations.

We define the distance function  $d$  in terms of a set  $M$  of segments on a line. The function  $d$  maps elements of  $M$  into the set of nonnegative real numbers. We write:

$$1(a). \quad d: M \rightarrow R^+, \text{ or}$$

1(b).  $d(A, B) \in R^+$ , where  $A$  and  $B$  are the endpoints of the line segment.

In the more leisurely paced development of school mathematics, the luxury of a less complex notation is typical. Distance is labelled simply as  $m:AB$  or  $AB$ . This development uses the functional notation to emphasize the functional character of distance and because the  $d(A, B)$  notation allows a more precise rendering of the primitive ideas that, taken together, constitute distance. In the notation  $d(A, B)$ , the  $d$  names the functional rule, the argument  $A, B$  indicates the segment endpoints in order (we are considering the distance from  $A$  to  $B$ ) and the entire symbol  $d(A, B)$  is the real number signifying the distance.

The distance function needs some other properties if it is to be sufficiently powerful to treat the usual problems encountered in school mathematics. In order to strengthen the function, some rather obvious characteristics are needed—the sort that are so obvious to the experienced adult that it is easy to overlook establishing them in the elementary school classroom, but the distance function is not complete without:

these primitive concepts. We state them first in the functional notation:

2.  $d(A, B) = d(B, A)$ . The distance from a first point to a second is the same as the distance from the second to the first.

3. If  $d(A, B) = 0$ , then  $A = B$ , and conversely. If the distance between two points is zero, then the points named by  $A$  and  $B$  are not different but the same. The "and conversely" indicates that the distance from a point to itself is zero.

4. If  $B$  is between  $A$  and  $C$ , then  $d(A, B) + d(B, C) = d(A, C)$ . This assures that if two segments are laid end to end on the line, then the sum of the length of the segments is the number naming the length of the union of the segments.

5. If  $B$  is between  $A$  and  $C$ , then a whole number  $p$  can be found such that  $p[d(A, B)] \geq d(A, C)$ . This may be translated to say that if segment  $AB$  is a part of segment  $AC$ , then it may be copied enough times to go beyond  $C$  on the line (see fig. 2). A mathematician would state that this makes our geometric space Archimedean.

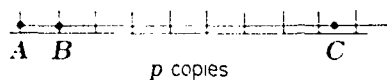

Fig. 2

6. If segment  $AB \cong$  segment  $CD$ , then  $d(A, B) = d(C, D)$ , and conversely. This says that segments that are congruent have the same length, and if two segments are the same length then they are congruent.

When taken altogether, these properties (1 through 6) constitute the idea of distance on the line. This complex of ideas provides the intuitive insights each student should acquire in matriculating through school. But are these characteristics best acquired by providing experiences with them separately, or should the young child encounter them en masse? Many children's early encounters with measure are in terms of com-

putational formulae. These formulae and experiences subsume and depend implicitly on the six primitive properties stated above. Consequently, the ideas are muddled together rather than providing the child operational control and understanding of each property. Because they are so obvious to the adult, it is easy to overlook the problem of the child who has difficulty with one or more of these ideas.

The distance function is frequently "strengthened" by imposing a coordinate system on the line to turn it into a number line. A function is used to map the real numbers onto the number line in a one-to-one fashion. If  $\varphi$  is such a coordinatizing function and  $A$  and  $B$  points of a line  $l$ , then  $d(A, B) = \varphi(B) - \varphi(A)$ . This assures that the number line is dense, ordered, and Archimedean. (By dense we mean that between any two points a third can be found.)

The ruler-placement postulate of several geometry texts currently used in American schools describes implicitly a coordinatizing  $\varphi$  function. The label "ruler placement" is suggestive of the close parallel between the physical reality of the use of rulers and actions with rulers but is actually a description of the ideal world of mathematics within the model of reality. Use of the descriptive "ruler placement" label may well obscure the distinction between physical reality and the world of mathematics.

Coordinate systems are intrinsic to most adult experiences with measure. Typically, coordinates or scales provide the base for comparison of size. Most conversions from one measure system to another are based

on the scales possessing properties 1 through 6. Whether within the metric system or between the metric and English systems, the shift from one scale to another involves the same type of transformations. Most commonly, the transformation is simply a dilation, a stretching or shrinking, caused by multiplying each number of the original scale by a positive real number. Converting a meter scale to a kilometer scale is accomplished by multiplying each coordinate on the meter scale by  $1/1000$ . Note the transformation simply relabels points. The shrinking is only apparent because of the relabeling. The point is that the mathematical principles are the same whether the conversion is within one system of measure or whether it involves both the English and metric systems. Many students have become so bogged down in the computation associated with conversion that they have missed the basic idea of the transformation.

The conversion of one temperature scale to another illustrates one more transformation that is sometimes employed in conversion, namely, moving the zero point by shifting or translation. Both translation and dilation are used in this conversion. Suppose a line is labeled to serve as a model for Fahrenheit temperature. This is a coordinatization of a line. By subtracting 32 from each coordinate, we can shift the coordinate system. Multiplication of each coordinate by  $5/9$  shrinks the scale such that we have established a new coordinate system, one which serves as a model for Celsius temperature (see fig. 3).

All that has been accomplished by these

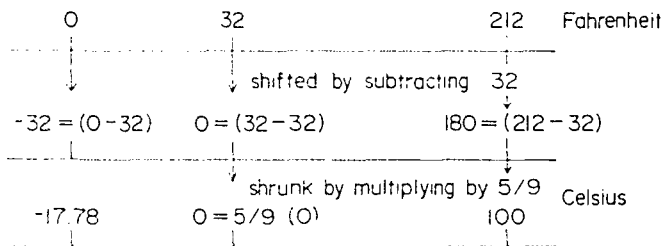

Fig. 3

transformations of stretching or shrinking (dilation) and shifting (translation) is conversion from the Fahrenheit scale to the Celsius scale. Since each transformation is one-to-one and onto, the process could be reversed to derive the Fahrenheit scale from the Celsius scale.

The transformations of dilation and translation provide the mathematical means of converting between the measure scales. Dilation, the multiplication by a positive real number, is messy in the English system, with fractions such as  $1/12$ ,  $1/36$ , and  $1/5280$ , and with whole numbers leading to comparable computational drudgery. A primary payoff of conversion to the metric system is that dilation is always in terms of multiplying by a power of ten.

Conversion from one measure scale to another is an exceedingly useful property of a measure system. Dilation and translation do not alter the basic properties of the underlying coordinate system that is the scale. The ratios of distances between points labeled in one system are the same as the ratios of the distances between the points in the other system. That is, the ratios are *invariant* under the transformations of dilation and translation. The measure systems most commonly used by scientists and by the man on the street possess this property of invariance. Such measure coordinate systems are frequently called *ratio scales*.

The distance function was established above in a peculiar manner so that it would be exactly analogous to children's first classroom experiences with measure. The peculiarity is that the domain of the function is restricted to a single line; that is, any measuring must be done on a single line. Children's preliminary work in the early grades with number lines and with rulers is typically so restricted. Perhaps again because it is so obvious to adults, it is easy to overlook the difficulties in moving from measure in the one-dimensional space of a single line to the more advantageous situation of measure within two- and three-dimensional space. Rather than care-

fully developing the mathematics of a more general length function, four specific problems of moving from the distance function—with limited domain and restricted applicability in the world of mathematical models—to the more general concept of length will be highlighted.

*Problem 1.* How can lengths of segments on two different lines be compared? In figure 4, is  $m\overline{CD}$  greater than, equal to, or less than  $m\overline{AB}$ ?



Fig. 4

The nature of the problem requires that a relationship be found that will connect the distance functions for line  $k$  and line  $l$ . The critical characteristic of segments that needs to be established is that all congruent segments have the same measure whether they are on a single line or not. We note that property 6 of the distance function is the parallel of this problem but is restricted to a single line. Indeed, as an idea, the single-line case is contained in the new property applying to more than one line. The particulars of the mathematics of establishing that the congruence relation partitions the space into equivalence classes of line segments will not be addressed. Rather, the point of this discussion is that the analogue of the mathematical problem is not intuitively obvious to all children as Piaget's seriation interviews show. This problem of mathematics needs to be addressed as a learning and teaching problem if children are to understand the concepts of length.

*Problem 2.* How does one find the length of a broken line segment? That is, given a figure like figure 5, how can one assign a number that will give the length?

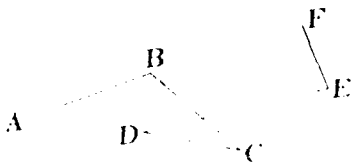

Fig. 5

Ultimately the solution of this problem provides the capability of computing the perimeter of polygonal figures. By using the solution to the first problem and allowing ourselves to add the distances for each segment, we can compute the length of the broken segment. Careful treatment of this problem would require a mapping from the set of all broken segments to a single line on which we could apply the distance function  $d$  (see fig. 6). We would need to define our mapping neatly for each segment so that the map of  $B$ , the endpoint of segment  $AB$ , and the map of  $B$ , the endpoint of segment  $BC$ , would fall on the same point  $\bar{B}$  of line  $l$ , so that the images of the segments overlap in no other points and so that the length of an image segment is the same as the length of

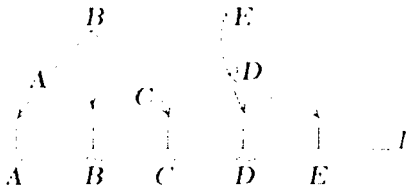

Fig. 6

the original segment. This is similar to assuming a nonstretchable string is on the broken segment  $ABCDE$  and is moved to the line  $l$  on which we can apply the distance function. We should restrict this mapping to apply to only a finite number of segments constituting the broken segment. Teachers need to provide children with a variety of activities transforming broken segments onto a coordinatized line. This may be as simple as constructing a broken segment with strung-together soda straws to be picked up and juxtaposed against a number line or the reverse, which is picking

up a bendable number line and laying it on a broken segment. The experiences should address helping children acquire a feeling for the conservation of length under the transformation, but it is much easier to focus on the outcome, namely, that we can find the length of a broken segment by summing the distances of the segments making up the broken segment.

*Problem 3.* How does one determine the minimal distance between two points? In figure 7, is  $d(A, C) < d(A, B) + d(B, C)$  for any point  $B \in P$ ?

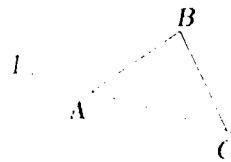

Fig. 7

The solution of this problem is generally accomplished by assuming an additional characteristic for  $d$ , namely, for any three points of the space  $A, B$ , and  $C$ ,  $d(A, C) \leq d(A, B) + d(B, C)$ . Note that this statement encompasses the single-line case.

*Problem 4.* The final problem is more complex. We would like to be able to determine the length of curves in space. Given a curve  $\Gamma$ , as in figure 8, how can we determine its length?



Fig. 8

Solution of this problem is necessary if we are to be able to find the circumference of circles, the length of a portion of a parabola, and other such problems in which the figure is not a broken line. Solution of this problem requires a more refined

treatment of broken line segments in order to generate the set of all broken line segments that approximate the curve so that limit or bounding processes may be applied to the set. Children can gain some insight into the limit processes involved by comparing the measure of a curve formed by a jumping rope placed on the floor with approximations made by first using five-centimeter sticks and then using decimeter sticks. A careful mathematical solution to the measure of curve length may be found in A. L. Blaker's *Mathematical Concepts of Elementary Measurement* (1970).

This concludes the mathematical description of distance and length. The description depends on determining a characteristic function, the distance function  $d$ , and then exploring carefully the properties desired for this function. Primary among these properties were those relating the joining segments and addition, congruence and having the same measure, and finally comparison.

The distance function and its defining properties are ubiquitous in that they permeate the world of this mathematical model and their analogues are those used and observed in the world of physical reality. They are obvious; but therein lies the difficulty in working with the young child. As adults and teachers, we possess a global gestalt of the distance function and its properties. Since the analogues of these properties are present within the world of physical reality, it is easy not to give them singly the attention they need if they are to be acquired by children. The implication for teachers in planning for instruction is that activities for each property need to be sought and included within the child's preliminary experiences before stressing the computational formulae for length and distance.

The characteristic that has no analogue in the world of physical reality is that there is a single, unique number called the distance between two points in this ideal world of the mathematical model. However, the physical world of observation

with the inexactitude of ruler placement and reading offers no such succor to the learner.

### Area

The idea of area is mathematically similar to the idea of length. There is a characteristic function for area just as for length. It possesses defining properties some of which are similar to the defining properties for the distance function. Analogues of most of these properties are evident in the parallel world of physical reality. These primitive, defining properties on which a full-blown area function is built are often slighted by a too rapidly paced instructional sequence to the familiar formulae for figures such as squares, triangles, and rectangles. The primitive subconcepts constitute the important intuitive foundation for the children's acquiring the computational formulae.

The domain of the area function is limited initially to the most simple case, namely, the set of all polygonal regions. A polygonal region, such as the one displayed in figure 9, is a closed, broken line segment together with its interior. The figure may be cut up or partitioned into a finite number of triangular regions by connecting appropriate vertices with straight line segments. We shall label the set of all polygonal regions  $R$  and all elements of the set  $r$ .

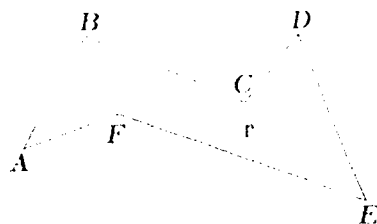

Fig. 9

The area function  $A$  associates a *single* positive real number with each polygonal region  $r$ . We write:

$$1(a). \quad A: R \rightarrow \mathfrak{R}^+, \text{ or}$$

$$1(b). \quad A(r) \in \mathfrak{R}^+.$$

Among the several primitive, defining properties for the area function that are similar to the distance-function properties is the one concerning the areas of congruent regions. For the distance function, we require that congruent segments be associated with the same real number. Analogously, the area function maps congruent regions to the same real number. We write:

2. If  $r_1$  and  $r_2 \in \mathfrak{R}$  and  $r_1 \cong r_2$ , then  $A(r_1) = A(r_2)$ .

For the distance function, if  $d(A, B) = d(C, D)$ , it could be concluded that  $\overline{AB} \cong \overline{CD}$ , but the area function does not behave so nicely; equal areas are not necessarily the result of the area function applied to congruent regions. A rectangle that is 2 units by 8 units has the same area as a triangle with a base of 4 units and an altitude of 8 units. The area-measure characteristic function possesses unique defining properties setting it apart from other characterizing functions.

The area function, like the distance function, needs a mechanism for associating a number with combinations of elements from the domain. The join of two non-overlapping polygonal regions should have the same area number as the sum of the area numbers of the two regions. That is:

3(a). If  $r_1, r_2 \in R$  and  $r_1$  and  $r_2$  share only points of their boundaries, then  $A(r_1 \cup r_2) = A(r_1) + A(r_2)$ .

Piaget's observations of small children suggest that their acquiring a feel for the subtractive version of this property is a key element in their forming an operational foundation for area. This subtractive version is, namely:

3(b).  $A(r_1 \cup r_2) - A(r_1) = A(r_2)$ .

This property of joining regions and the previous property concerning congruence provide a necessary, logical foundation for examining area in terms of *tiling*, or covering a large region with uniformly sized pieces and counting them to ascribe a number as area to the entire region.

The three primitive properties of the area function that have been specified do not provide a means of associating a number with a region. Instead, they provide rules that this function must obey when given a rule for association. Typically, two different rules for assigning numbers to regions are used and intermingled in texts. One is the unit approach, which is a necessary component of the tiling, or covering, approach discussed previously. It simply identifies a standard unit with a particular region. This is usually a square with a side of length one unit.

4(a). If a square,  $s_1$ , has side of length 1, then  $A(s_1) = 1$ .

This provides a means of assigning areas to all polygonal regions if suitable theorems relating different types of regions are developed. We need, for instance, to relate the area of a square with side different than one to the area of the unit square. The areas of other polygonal regions, such as rectangles, triangles, and trapezoids, need to be related to the square. The unit length of the side provides a means of tying area to the real numbers, yielding several nice properties, such as order.

The tiling, or covering, approach based on the unit measure ultimately forces the learner to cope with problems of incommensurability. The fundamental idea of covering is simple and intuitive. This is not so for the ideas involving incommensurability; the concepts involved require considerable mathematical maturity and sophistication. Rather than face these sophisticated concepts directly, most texts elect to step around the problem by incorporating an equivalent approach that provides a more direct connection with the real numbers. We state that for a polygonal region that is a rectangle:

4(b). If  $b$  is the length of the base of a rectangle  $r$ , and  $h$  is the altitude, then  $A(r) = bh$ .

This provides an immediate association of all rectangular figures with real numbers



without our having to impose the limit processes necessary in developing version 4(a) carefully. It should be noted that 4(a) and 4(b) are mathematically equivalent; one can be deduced from the other.

Three comments are in order. First, we typically concentrate our instruction on the number that we associate with each polygonal region rather than the function rule or association itself. Classroom talk about the area of a rectangle of sides six units and five units identifies the area as thirty area units. This labeling of the result of the computation, or the *range value*, as the area function ignores the mapping. It is appropriate to label the result—thirty area units—as the area, but the function and its primitive, defining characteristic are a portion of the foundational intuition that each child needs.

Second, the careful mathematician would want to prove that if a polygonal region is cut up or partitioned in two different ways, then the same real number naming the area results. For example, if the pentagonal region in figure 10 were to be cut up first as shown by the dashed lines and second as shown by the solid lines, the mathematician would deem it necessary that the area function applied to the three triangles

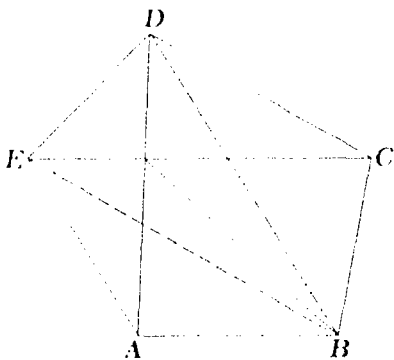

Fig. 10

from the dashed-line partitioning give the same number as the area function applied to the five triangles from the solid-line partitioning. This desire for uniqueness on

the part of a mathematician appears strange to many individuals because it seems so obvious based on our experience with measurement in the real or scientific world. It takes just so much paper to wrap a rectangular box, no matter how we cut it out (see fig. 11). This is another case in which an adult assumption leads to ignoring the need to provide a child with foundational, intuitive experiences.

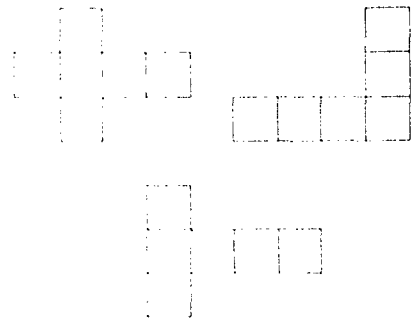

Fig. 11

Third, the choice of an area unit, be it explicit as in 4(a) or implicit as in 4(b), is arbitrary. We could have selected a unit triangle, a unit hexagon, or even a circle, although we would ultimately have to deal with the same problems for polygonal figures. The choices of 4(a) and 4(b) have an advantage in that they provide almost immediate access to solution of several fundamental problems concerning the area function and because they parallel so directly the instructional sequence of most texts. It should be noted in this context that Euclid's treatment of area did not involve a characterizing measuring function that depended on the real numbers. It also did not provide the same direct tie to the measurement of distance on a line.

The domain of the distance function was extended to encompass length in the plane and the length of curved lines. In an analogous fashion, the area function requires an extension of domain in order to treat areas of closed figures that are not polygons. We need to be able to apply our function to circles, ellipses, cardioids, and

other such figures, and, as in the case of the length function, we need to also extend the area function to treat areas not contained in a single plane. As in the case of the length of curved lines, the problem is solved by applying limit processes appropriately.

In summary, area measure is a function characterized by mapping closed figures to the positive real numbers in such a way that congruent regions have equal areas. A joining of a finite number of nonoverlapping regions produces an area equal to adding the areas of the regions, and a rule stating specifically how the real number naming the area is produced. As in the case of the length function, the primitive, defining characteristics are a necessary part of the foundational intuition that children need. These defining characteristics are so obvious to experienced adults that they are frequently overlooked in designing instructional sequences. The primitive, defining characteristics are paralleled in the real world that the mathematics models.

The properties that were encountered in area and in length are nicely parallel. In each case there is a defining function. Each function has several characteristics in common (see table 1).

### Volume

The mathematical model for the measure of volume shares many characteristics of the distance and area functions. Volume measure is a function  $\mathcal{V}$  that assigns to measurable sets in three-space a positive real number.

Children need experience with primitive subconcepts of volume measure paralleling those appearing in the table above, namely the concepts of congruence, additivity, unit, and comparison. Rather than explicating these concepts in terms of the characteristic function  $\mathcal{U}$ , it suffices to note (1) that children need experiences directed toward the attainment of these primitive subconcepts and (2) that the problems children encounter closely parallel the difficulties with the analogous subconcepts in other measure systems. It should be noted that children acquire these subconcepts for different measure systems at different points in time—most children do not attain additivity (conservation) for volume at the same time they attain additivity for distance.

The experiences that have been found to facilitate children's attainment and acquisition of these primitive subconcepts demonstrate a close comparability to those needed for the analogous concepts in other measure systems. The use of blocks to build volumes in a fashion similar to the use of area units as coverings for polygonal regions can strengthen children's intuitions for the unit, additivity, and congruence subconcepts.

Volume does present some unique problems corresponding to one subconcept with no exact analogue in length or area measure. The problem is the measure of irregular volumes. Niece parallelepipeds present relatively minor difficulties mathematically. The characteristic volume func-

Table 1

	<i>Distance</i>	<i>Area</i>
1. additivity	The join of two nonoverlapping segments has the same measure as the sum of the measures of the individual segments.	The join of two nonoverlapping regions has the same measure as the sum of the measures of the individual regions.
2. unit	The coordinatizing of the line provides the unit needed to assign a measure to a segment.	A unit is needed to assign a measure to a region. It is usually derived from a related distance function.
3. comparison	Segment $A \subset$ segment $B$ means $d(A) < d(B)$ from the triangle inequality.	Region $X \subset$ region $Y$ means $A(X) < A(Y)$ .
4. congruence	Congruent segments have the same measure.	Congruent regions have the same measure.

tion assumes its uniqueness through the principle of Cavalieri. Cavalieri's principle may be exemplified as follows: Suppose you have a deck of playing cards as pictured in figure 12(a). The deck is "pushed" as shown in figure 12(b). Cavalieri's principle asserts, informally, that although the conformation of the solid has been changed through parallel displacements of the points in planes, the volume is unchanged.



Fig. 12

This primitive concept is necessary for the full development of volume measure and for the deduction of computational formulae for many shapes, but note the complexity of the statement. Fortunately, the concept is more simple for children to apprehend than to state. It is a Piagetian conservation concept. Children need experience in deformation of solids embodying the Cavalieri principle. For instance, take a Slinky (one of those coils of spring steel that children like to run downstairs) and fill it with peas. Remove and count the peas. Deform the cylinder of the Slinky by pushing, and see whether it will hold the same number of peas (be sure the Slinky does not stretch in length). The Cavalieri principle provides a unique conservation principle that children need to acquire. Ultimately, the Cavalieri principle is realized in terms of being able to find the volume by multiplying the area of any cross section parallel to the base of a cylinder by the cylinder's height. Similar to area measure in that the volume measure depends on measures of lesser-dimensional space, the Cavalieri principle provides the tie to the area and length functions.

The treatment of volume suggested by the foregoing differs substantially from

what happens in many elementary school classrooms today. It suggests considerable experience in examining rectangular solids formed by stacking blocks and determining their volume. It suggests deforming these volumes in prescribed ways to emphasize the subconcepts. Most early instruction in volume, however, comes through experiences with liquid measure. Experience with liquid measure is important, but children need experience with both volume of solids and volume of liquids. At some point, the child will need to relate liters to cubic decimeters. The concept of liquid-volume measure appears to be easier for the child to acquire. The junior high school child frequently finds himself being introduced to volume of solids with little intuitive experience except for the presumption that volume of solids "behaves" quite like area. The child is frequently left to his own devices to bring liquid-volume measure and solid-volume measure into a common system.

#### Angle measure in the plane

A final example of a measure function in the sense of the mathematician's nice world of exactitude as opposed to the world of practical measurement is that of angle measure. The measure function for angles is considered because history and traditions confuse the definition of the measure function, as well as the fact that angle measure is more complex.

The length function and the area function are intuitively more obvious than angle measure for several different reasons. First, it should be noted that we can talk naturally with precision about length and area. The word length denotes an attribute of a line segment. The word area denotes an attribute of a region that is different than the region itself, but in the case of angle measure, the word angle is used for the angle itself *and* for the measure of an angle. Often you will encounter statements such as "The angle is twenty-five degrees." We can speak of the area of a square and know we are referring to the measure function. However,

not having a special word for the measure attribute of angles, we need to use a phrase like *angle measure* in order to remove the ambiguity of confusing an angle with its attribute. Some texts attempt to remove this ambiguity by writing  $\angle ABC$  for the angle and  $m \angle ABC$  for the measure of  $\angle ABC$ . This helps, of course, but does not remove the problem of ambiguity when teachers and learners are operating in an oral mode.

Second, the characteristics of the angle-measure function depend on the nature of the definition of the domain and its elements. It would be nice if we could simply say the domain is the set of all angles in the plane, but the history of mathematics indicates that there are at least a half-dozen alternate ways of defining angle. Angle has been defined by saying it is the rotation of a ray around its endpoint, by saying it is the wedge consisting of all the points of two rays with a common endpoint and all of the points of the rays in between, and by indicating that if two rays with common endpoint lie entirely within a half-plane, the angle is the set of points of the rays. Many of the alternative definitions are to be found in currently used texts. Corresponding to the choice of definition of elements of the domain is a set of intuitions that children need to acquire in order to possess a "feel" for the angle-measure function.

Finally, the nature of the range of the angle-measure map has a potential for providing confusion. The student of trigonometry, in coping with Demoiivre's theorem, may want to distinguish between angles with measures of  $75^\circ$ ,  $435^\circ$ , and  $800^\circ$ . From our experience we know angles of measure  $75^\circ$  and  $285^\circ$  are remarkably similar. (Is this a problem of the nature of the domain or of the range of the function?) A long, historic tradition of using degrees as the unit of the range set exists, when for many problems it is more natural to use radians and provide a more direct tie to the real numbers.

Rather than carefully describing the characteristic function for angle measure

and becoming bogged down in the problems discussed earlier, the following section highlights some of the desirable properties for the function. The function should map into the set of real numbers such that—

1. Every angle shall have a measure.
2. Congruent angles have the same range value.
3. If two angles are adjacent (that is, the angles have a common vertex and side but are nonoverlapping), then the sum of their measures should be the same as the measure of the angle formed by their "outer" rays.
4. Given the measures of the angles formed by three rays from a common endpoint (see fig. 13), it can be determined which ray falls between the other two. This is to say, given the measures of  $\angle AOC$ ,  $\angle BOC$ , and  $\angle AOB$ , selection of one of  $\overrightarrow{AO}$ ,  $\overrightarrow{BO}$ , and  $\overrightarrow{CO}$  as falling between the other two should be apparent.

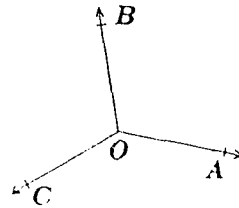

Fig. 13

5. Given the measures of two angles, it can be determined which angle is larger.
6. A unit measure for angles needs to be determined.

Most of these properties have an analogue in the length function and area function.

The primary difference in the measure-of-angles function comes from the fact that we generally prefer that the range be modulo a real number. If degrees are the range unit, then the angle measure  $A$  is expressed in terms of  $A'$ , a real number less than 360.

$$A = A'(\text{mod } 360)$$

This is to say,  $A' = A - n \cdot 360$  where  $n \in$  integers and  $0 \leq A' \leq 360$ . In terms of radians,  $A = A'(\text{mod } 2\pi)$ . It should be noted that a ratio-scale transformation converts the degree-unit scale to the radian-measure scale.

Each of the properties discussed above warrants the attention of the teacher or the instructional-materials designer in order to build the intuitive foundation from which the learner operates. The building of the intuitive foundation is more complex in the case of the angle function than in the case of the length function or the area function because the attributes of the domain set and the range set are affected by the choices established in respect to our traditions and history.

Angle measure is also complicated by the fact that alternative natural means of accurately describing angles and their measures exist. It is quite reasonable to describe angle measure in terms of ratios. For example, consider  $\angle ABC$  in figure 14. Some young children appear inclined to

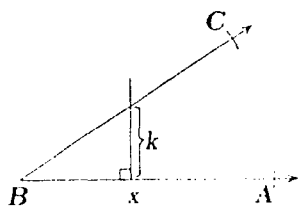

Fig. 14

find a point  $x$  a specified distance from  $B$  and then to determine a length  $k$  on a line perpendicular to  $AB$  through  $x$ . This procedure could be used to measure all angles, but it poses some inconveniences. This method, similar to a carpenter's use of his square to measure angles, is a natural alternative to measure in the degree sense.

### Mass

Understanding of mass is more complicated for children than are the understandings associated with length, area, volume, and angularity. The crux of the matter is perception. To hold two objects in

your hands and say which has the greater mass is difficult. In determining length comparisons, the child can simply place one object against another and look. Apparatus is required to provide the child with the perceptual refinement to generate his mathematical model for mass. The child's perception seems a step further removed from the model for mass that he is building than in the case of these other measures. Two words, *equilibrium* and *comparison*, serve to categorize some of the perceptual difficulties involved.

Equilibrium is a word describing the system of balance necessary to the manipulation involved in finding the mass of an object. Given a quantity of flour on one pan of a beam balance, as shown in figure 15, the learner must establish a balance

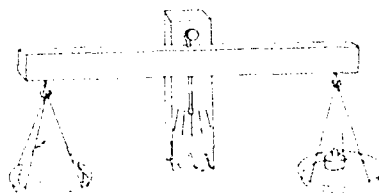

Fig. 15

by adding standard masses to the other pan. Determination of the equilibrium involves perceptions of the objects or their attributes that appear indirectly related to the original quantity of flour. For one thing, the mass added to the nonflour pan is perceptually distant from the flour—how can the mass added to the nonflour pan be concerned with an attribute of the flour? Also, the determination of the equilibrium state hinges on the marker on the scale at the top of the picture, but this marker is not a direct measure of the mass—a number to be part of the mathematical model—but an indication or system of whether a state of balance is achieved. This indirectness of relation of the underlying perceptual base to the mathematical model is unavoidable. It introduces a complexity into the learning processes. Developmental psychologists have shown that children's acquisition of

equilibrium ideas comes quite late in their conceptual maturity.

The second term, comparison, is another concept that is required of children when balances are used to provide the fundamental perceptual data for building the measure concepts for mass. These ideas hinge on the child having a usable sense of the transitive property, " $a < b$  and  $b < c \Rightarrow a < c$ ," the heart of the comparative processes. The child should clearly encounter the transitive property in measure contexts other than mass; this would give the child a background on which the teacher could build in preparation for transfer to the context of mass. Nevertheless, because the comparative aspect is so fundamental to mass and is so late in reaching fruition in the mind of the child, it demands special attention by the teacher. Confounded by the perceptual difficulties of a balance system, it provides the child with significant problems.

The mathematical model for mass generated from perceptual data by the child is very similar to the models for length, area, and volume. Again, the important subconcepts desired to characterize the mass-measure function are congruence, additivity, unit, and comparison. Acquiring the comparison idea appears to be at the heart of children's difficulty. In passing, one should note that weight measure presents the same order of learning difficulties as mass measure. Mass is a more general concept than weight, since weight varies with variation in the strengths of gravity fields. However, since it is hardly practical for children to compare the weights of a given mass in different gravity fields, there is probably little to be lost by using mass and weight interchangeably during the early years of school. The mass-weight distinction is grounded in scientific principles rather than mathematical constraints, and its placement in the curriculum is within the domain of the science educator.

### Indirect measures

The importance of mass and weight to the mathematics curriculum is that it in-

troduces the concept of perceptually indirect measure. Length, area, volume, and angles are measured with units that are lengths, areas, volumes, and angles—the unit *looks* like the object being measured; but standard masses seldom look like the objects on the opposite pan of the balance.

Measuring mass is also indirect in the sense that an intermediate device, the balance, is used in the measurement. Unlike rulers or protractors, which simply provide copies of the units used in the measuring process, the balance serves to magnify our senses. Here is the first introduction of a measuring tool or instrument.

Measuring instruments may also measure in yet another indirect way: they may measure effects. In a zero-gravity field, mass may be measured by noting how much a spring is stretched when it pulls the mass with a given rate of acceleration. Temperature is measured indirectly by noting the effect on the length of mercury or alcohol in a narrow tube. Electrical current is measured by the force it effects on parallel wires.

Thus, measurements may be indirect in three different ways: perceptually different units may be used, measuring instruments may magnify senses, and measures may be made by noting effects on other objects. The extension of measure to indirect factors calls for a blending of both mathematics and science. The properties of mathematical measuring functions must still be preserved, but properties of scientific measurement must also be considered.

The measure functions length, area, volume, angle measure, and mass have been considered from a mathematical point of view. For each it has been observed that only one measure corresponding to a given domain element exists. Further, some characteristic primitive subconcepts exist for each function and are necessary if a learner is to build a functional gestalt. Many of these characteristics, such as the equal-measures-for-congruent-domain elements, additivity, and ordering, appear common to all the functions.

Measure in mathematics has a key element of exactitude that is missing in scientific or practical measurement. It is measure in the ideal world of the mathematical model of physical entities. This point of view concerning a distinction between measure in mathematics and in the physical world is relatively recent. A mathematician or scientist in the age of Euler would not have worried about the distinction; indeed, he might not have considered it valid. Freeing the mathematics of measure from physical reality awaited a careful formulation of limit processes and the arithmetization of analysis. It should be noted, in passing from this discussion of mathematical measure functions to the following discussion of measurement processes in science, that not all is simple. We have not attempted to argue the separation but rather have assumed it as a foundation of our discussion. The philosophical arguments are not simple and are beyond the scope of this document. The interested reader may turn to Eddington (1939), Bridgman (1938), and Churchman and Ratoosh (1959) if he is inclined to pursue these distinctions further. The point of the distinction is this: the learner needs a different sort of intuition when playing in the garden of exactness than when working with the processes of measurement. Sometimes these differences are confusing to, and confused by, children.

A concluding point about measure in mathematics is in order before turning to measurement in the world of the scientist. A modern mathematician often considers a space of objects or entities to be a measure or metric space. A space is defined by McShane and Botts (1959) to be metric if it is a set  $S$  with a function  $m$  meeting the following minimal set of conditions where  $x, y, z \in S$ :

1.  $m(x, x) = 0$
2.  $(x \neq y) \rightarrow m(x, y) = m(y, x) > 0$
3.  $m(x, y) + m(y, z) \geq m(x, z)$

Each of the examples—length, area, and angularity—meets these minimal criteria; but, in addition, because of what our intuition and experience indicate is useful and productive, we have imposed additional characteristics on the characteristic function and, indeed, on the entire space. The conditions for a topological space to be metric are powerful in that they accommodate many different characterizing functions. Perhaps these three characteristics need to be stressed above all else, but that alone would not be sufficient to provide the typical learner with a sense of control for all the measure systems needed in mathematics. One must cope with the characteristics of each metricizing function in the sense of what gives it a uniqueness.

#### Measurement in science

The measure concept of mathematics is useful to the scientist. It is his model for the practical world of observation. The scientist should understand the concepts involved, for he needs to fit his observations of reality to the mathematical model. In many respects the scientist's world is more complex. It involves more ambiguity, relies on his observational prowess, and requires some skills not necessary in the clean world of mathematics. Measurement for the scientist contains the measure of the mathematician and much more. Following are examples of measuring scales in science offered as examples of the differences.

The geologist uses relative hardness of minerals as one tool to help identify minerals. A mineralogist, Frederick Mohs, suggested in 1822 a hardness scale. Following is Mohs' hardness scale:

- |             |             |
|-------------|-------------|
| 1. talc     | 6. feldspar |
| 2. gypsum   | 7. quartz   |
| 3. calcite  | 8. topaz    |
| 4. fluorite | 9. corundum |
| 5. apatite  | 10. diamond |

To help identify a mineral  $x$ , scratch it with each of the identified elements of the

scale. Most steel will not be scratched by apatite but will be scratched by feldspar. The hardness of any mineral can be determined this way. There are intermediate stages on the scale; a fingernail typically would register about  $2\frac{1}{2}$ . To each material can be assigned a scale number by a process quite similar to the old rock, paper, scissors game. However, there are problems: some minerals have one hardness along the axis of their crystal structure but another across the axis (e.g., kyanite); therefore, the apparent characteristic function of the metric system simply is not a function. Further, there is not a nice proportionality in the scale. The relative difference between the hardness of diamond and corundum is not the same as between quartz and topaz. Indeed, the numbers do not provide the base for operations and comparisons between points on the scale that would make for a "nice" measure function.

For the geologist Mohs' hardness scale provides a useful measure system. It is also a prime example of the problems of observation in scientific and practical measure. It does not yield a predictive mathematical system. It provides a scale for categorization and for taxonomic purposes. In terms of our initial description of the relation between the physical world and the model world of mathematics, the operations of scratching and the perception of scratching provide the "fit" for a weakly ordered set that is the model.

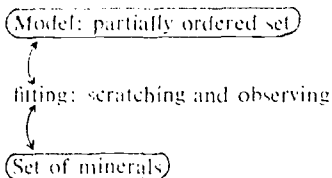

The mathematics of the model does not provide a rich base for prediction. Mohs' hardness scale depends almost totally on observation. It is not a ratio scale, as was considered in conjunction with the scales used for measuring temperature. Ratios of

distances between relative hardness points are not preserved when multiplied by positive numbers.

Mohs' scale is an example of another basic category of measure scales, namely, the ordinal scale. It merely assigns a relative order to entities. The large majority of percentile achievement scales used in schools are also ordinal scales. If one student scores at the eightieth percentile on a standardized mathematics test and another scores at the fortieth percentile, you cannot state that one knows twice as much as the other; at best you may conclude that one student achieves better than the other. That is, an order has been assigned to their performance on the test.

Nominal scales provide a third category of measure function that contrasts sharply with ratio scales and ordinal scales. Suppose a set of scientists was partitioned into the four categories of mathematicians, physicists, chemists, and psychologists. If each of the four subgroups were counted and the number in each category assigned to the name of the category, a nominal scale would have been created. This type of measure function is the weakest of the three types of measure scales in terms of its inherent mathematical characteristics. It is very useful for many kinds of information-gathering and organizing tasks.

The Richter scale, invented in 1935, is used to measure the magnitude or the amount of energy of an earthquake. The Richter scale is the range of a function that assigns a number to the maximum amplitude of an earthquake's shock waves. The logarithm of the maximum amplitude is used to assign the number. Suppose the graph in figure 16 is the record of a shock wave observed at a seismographic station. The  $\log_{10}(a) - 3 = \text{Richter number}$ , if  $a$  is the maximal amplitude recorded in the course of the earthquake for a given distance from the earthquake. Richter scale values are dependent on the distance to the epicenter of the earthquake. Empirically derived tables are used to take into account this distance factor at different



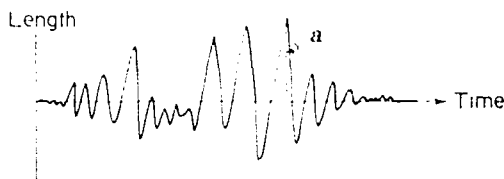

Fig. 16

observation posts. Now  $a$  is an observation. It depends on standardized measurement recording devices. Taking the log of the measure is not necessary unless the scientist desires the convenience of being able to graph on a reasonably scaled and sized piece of paper. Thus, at many points on the practical side of measurement, the arbitrariness in the selection of units is shaped by the conditions of measurement and the convenience of the measurement devices. Note that an earthquake of Richter magnitude 8 is actually indicating an energy of 10,000 times the energy of an earthquake of magnitude 4. Further, because of the conservative factor of measuring only the maximal amplitude rather than all the energy released by the earthquake, it is estimated that an error factor of  $10^3$  is introduced. There is, indeed, no exact or precise measurement of the total energy released by an earthquake involved; rather, calculated and refined estimation of a single symptom of an earthquake's energy is given by the Richter scale. A precise and complete measurement model for the total energy release of an earthquake does not exist, but the Richter scale is a sufficient approximation to be a useful, predictive model.

The Mohs' hardness scale and the Richter earthquake magnitude scale are not part of the everyday life of most learners. They provide nice contexts for study of the role of approximation and the arbitrary nature of assigning scale or measurement values to physical phenomena. They are relatively free of the confounding effects on learning provided by prior measuring experience and linguistic usage. Thus, they differ from the more commonly used base for teaching

concepts and processes of scientific measurement. Length, area, volume, temperature, weight, time, and mass are each used much more extensively to establish concepts and processes of scientific measure. The measuring of length and area are typically used as an instructional base for establishing key concepts and processes of scientific measurement with the young child.

One characteristic of scientific measurement is the idea of arbitrariness. Within the measuring context, the measurer must select an appropriate unit of measure. Two concepts need to be established: first, that the measurer has a choice, and second, that some choices are better than others. In the measurement of area, I could elect to cover a region with triangles, with squares, or even with circles. My choice would depend on what I use for my mathematical model—which would fit best with the rules of operation that I desire to use and the type of predictions I want to make. My choice of unit may also depend on the kind of instruments I have available. If I have a rule scaled in decimeters, then I probably would not elect to measure in terms of centimeters. (This provides a practical yet compelling reason to replace English-system measurement tools with metric devices.) For most measure systems, tradition and obvious convenience establish my selection of *type* of unit. After selecting the type of unit, I need to select the *size* of unit. I would not elect to use a kilometer scale to measure the length of a room nor a centimeter scale to measure the distance from Anchorage, Alaska to New York City. Judgment depends on convenience and the error factor that is

acceptable. The point is this: the selection of a unit for measuring depends on the *choice* of the measurer; it is arbitrary. In working within the English system, the matter of arbitrariness appeared to be easy for the teacher to establish. The same system—feet, inches, yards, rods, and miles—seemed so different (because of the horrendous conversion computations) that the choice factor in selecting an appropriately sized unit seemed relatively clear. With conversion to metric, will it be so easy to establish arbitrariness and choice of the measurer as a factor?

Unit selection is not necessary for a mathematician to have a metric space. However, many of the metric functions have a unit as an important characteristic in determining their nature. The Archimedian characteristic of length and, more generally, the tying of length to the real numbers, implicitly specifies a unit for the length function. Note, however, that the scientific process of measurement contains the characteristic of providing the user a choice of picking size. The selection of the size of the unit is within the mathematical model but does not depend on any external characteristics, such as instruments used or what is to be measured.

Another characteristic of the scientific-measurement process is the estimation and approximation process. This characteristic has several facets. First, and particularly distinctive, is the fact that measurement scales are based on rational numbers. The mathematician will state that the distance between two points is exactly  $\sqrt{2}$  units; but rulers are designed to measure units and fractional parts of units. Indeed, limitations that are imposed by the selection of measuring instruments and by the base unit mean that limit processes cannot be used arbitrarily to approximate a length that is an irrational number. Necessarily, measuring entails approximation and error, and the learner must become aware of this fundamental fact of life.

Historically, measurement evolved as a counting process. Whole numbers were

used to describe the number of units of magnitude necessary to measure an object. Indeed, we could have included measurement systems based exclusively on whole-number counting in our discussion of measure. The evolution of measurement concepts in Greek mathematics can be construed as leading from counting to ratio concepts and ultimately, in the idealized Platonic mathematics of Eudoxus and Euclid, to modification of the ratio and proportion to remove the ambiguity of incommensurable measures. Hence, in a real sense, coping with the practicalities of measure established the ideal world of the mathematics of irrational numbers.

The measurer should also recognize the implications of error being part of the measurement process. If a measure involves error, then any operations on that measure apply to that error. Learners need to develop an awareness of this. If the length of an object is observed to be 20 cm with an error of 0.05 cm, then if the measure is multiplied by five, the error as well as the measure is multiplied by five.

The above discussion of arbitrariness and approximation has not developed the particulars of all that is involved. Rather, the point is that among the goals of teaching measure—be it in the context of mathematics, science, or practical application—the teacher needs to help learners realize that there is more to the process of measure than the ideal world of the mathematical model indicates. Error and approximation are part of measurement.

Many of the processes of measuring taught in school mathematics address problems of improving accuracy or reducing error of observation in a systematic way. A student may understand the measure concept of length but may not yet have realized the necessity and advantage of careful placement of the zero point of a ruler or the zero ray of a protractor. Although the learning of the metric concepts and the learning of the observational skills typically progress together, these distinctive observational skills require careful attention in

their own right. Judging a length in terms of the confidence interval derived from the unit of observation is also a portion of the scientific skills and concepts used to control error or accuracy. That is, to judge that point  $B$ , the endpoint of  $\overline{AB}$  in figure 17, falls within one unit around 12 is not required by the mathematics of measure but is required as an integral part of the measuring process in science. Although significant digits, relative error, absolute error, and many of the processes used to identify and control error have nice mathematics within the operations and the background concepts, it should be recognized that these are not part of the foundations of measurement; rather, these processes are dictated by the necessity for a rationale for processes and skills directed toward improving the observational processes. This is not to say that these concepts and skills should not be addressed in the mathematics classroom. Rather, it is to say that children may be confused in acquiring understanding of the measure functions and control of the observational processes and skills if their encounters with these two concepts are not kept clear and distinct.

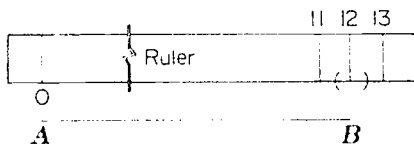

Fig. 17

Klopfer's (1971) statement of a taxonomy of educational objectives for the teaching and learning of science recognizes the discreteness of observational and measuring processes. Tying these processes to use of appropriate language, selection of appropriate instruments, estimation of measurements, and recognition of limits of accuracy, Klopfer is careful to remove model characteristics and formulation from the observing and measuring processes. Herein lies a problem: for the novice developing a measurement system for, let

us say, length by an inquiry or discovery process, it is clear that the length function is part of Klopfer's separate and distinct "model characteristics and formulation." After the length function and its characteristics are acquired, is this a part of a theoretical model to be tested and, perhaps, reformulated? Clearly not. But, in the teaching of science, it is not precisely appropriate to label the length function as a portion of the measurement instrument. Even in talking about processes of scientific inquiry, some knowledge should be accepted as such. More importantly, the teacher of science needs to think carefully about the mathematical modelling aspects of his science, recognizing that not all models are in the process of formulation even in the teaching of inquiry processes.

A final word concerning science, mathematics, and measurement is in order. The measure functions of the ideal world of the mathematical model are firmly grounded in the world of the practicalities of measuring. The models are refinements of what was and is observed in manipulating real objects. The process of relating actions or operations with objects to operations in the mathematical realm is a powerful idea of mathematics and model building labelled with the word *homomorphism*. A simple example of a homomorphism is that of sets with the operation of union and numbers with the operation of addition, as shown in figure 18. A homomorphism is a function that relates operations within one set to operations within another set. This is precisely the structure that relates using real objects in building a model of operations (such as joining line segments end to end for determining length) to using the characteristics of the length function in building a mathematical model of the length function. Clearly, children need to acquire concepts, skills, and intuitions relative to the real world of operations within the physical and manipulative context; this supports and extends the in-

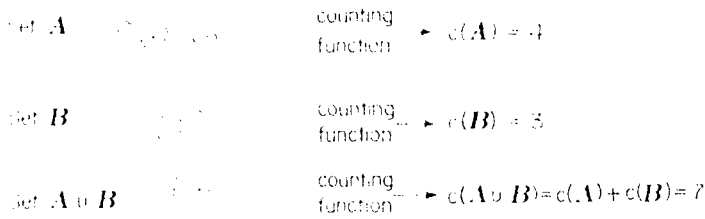

Fig. 18

tuitions within the model world of mathematics. The model world is, to a large extent, a world of symbols and operations on those symbols, each operation possessing an analogue or parallel in the physical world. The building of homomorphisms between the physical world and the constructed world of the mathematical model is the heart of the scientific-inquiry processes so critical to the development of science. Klopfer's higher-level objectives for inquiry teaching and learning are, indeed, succinctly summarized by saying that the taxonomy is directed to building "morphisms" in a calculated way. Mathematics teachers can support and extend the development of intuitions for scientific inquiry by maintaining a stress on the homomorphic or model-building aspects of measure. This is to say, a mathematics teacher should constantly stress the difference between the physical world with its operations and the model world with its operations, while at the same time reflecting that the operations are mirrored in each other. Concepts, skills, and intuitions must be developed with some thoroughness in each system, for learning in one system is supportive of learning in the other.

#### Teaching measure: problems and activities

In the foregoing section, measure was examined from the mathematical point of view. The purpose of this section is to consider pedagogical approaches to measure from the vantage point of instructional and psychological research.

Three remarks are in order before we begin. First, the research findings of the

child-development psychologists are generally consistent with the orientation to primitive subconcepts for each characteristic measure function. The problems in concept acquisition identified by such researchers as Piaget, Inhelder, and Szeminska (1960), Smedslund (1963), Steffe and Carey (1971), Lovell (1971), Skemp (1971), and Sinclair (1971) tend to localize on the child's failure to incorporate a subconcept into his cognitive schemata for measure.

Second, the word *intuition* was used freely in the preceding section. This section reflects an orientation toward the child's constructing perceptual and conceptual intuitions based on his interaction with the physical environment or with the homomorphic world of mathematical structures and operations in measurement. The components of the homomorphism provide the base for the intuition. Indeed, intuition in the homomorphic structure of measure is similar to what psychologists label with the word *transfer*. It differs from the traditional views of transfer in that the "morphism" provides an orienting connection between the structures. The functional connection is stronger than analogy, common elements, and other mechanisms identified as facilitating or establishing transfer. Transfer is, in a sense, "rigged" or "wired" by the tight, functional relationship between the domain and range sets and their respective operations. Intuition, then, is constituted of concepts learned on each of the "sides" of the homomorphism — the real world of manipulation of physical entities and the world of the mathematical model.

Third, ideas and concepts of measurement are not unique to the particular characteristic-function system. There is a parallelism between systems of measure. In some cases the parallelism is weak: there is little similarity between the structure of Mohs' hardness scale and the measure system for volume. In other cases the similarity is strong: in the English system, foot-pounds and BTU's "behave" in the same way. Many of the primitive sub-concepts for length have an almost exact analogue in area measure and in volume measure. In the traditional sense, the parallel structures indicate transfer to be an important instructional goal. On the one hand, it appears surprising that transfer is seldom an outcome of instruction, given the several measure structures that a child encounters in the elementary school. The common elements for the measure structures—such as additivity, units, congruence, and comparison—would appear to facilitate transfer, but children and adults often need to relearn these common characteristics of measure systems when encountering a new system of measure. On the other hand, lack of transfer may not be surprising but should be predictable from what is known about how children learn. The common elements are system ideas—part of an interrelated complex that provides the foundation of measure structures. The child's capability for handling and using measure structures characterizes the mature learner who has attained the formal reasoning stage of the Piagetian model of cognitive development; perhaps curricular designers and teachers expect transfer before children are ready. Although children encounter each of the ideas before attaining the formal reasoning stage and can indeed use the concepts separately, can they use them in the structural sense? Perhaps consideration of transfer as a specific objective of instruction should be delayed until the child attains the maturity of the junior high school years and then be addressed with concentrated attention. A potentially significant

hypothesis concerning the teaching of measure is whether children who are at the Piagetian formal reasoning stage can be led more easily to transfer concepts from one measure structure to another if the primitive subconcepts are emphasized in instruction for children at the pre-formal operations stages of development.

The parallelism between measure functions discussed in the preceding paragraph presumes that the functions are alike. The parallelism facilitates transfer between ratio-scale measure functions. Ratio-scale measure systems possess the most powerful inherent mathematical structure and are, consequently, the most used and pervasive of measure systems. All metric scales are ratio scales. Some useful metric measure scales are, of course, derived scales in that they are combinations of directly measured attributes. Velocity is such a derived scale, since it is the composition of a distance function and a time function. For derived scales, the ratio characteristic may be obscured; a teacher may therefore want to present learners with situations in which all but one of the measured attributes are held constant in order to highlight the ratio character of the derived scale.

But not all measure functions and scales are alike. Previously, we examined ordinal scales, such as Mohs' scale, and nominal scales, such as those counting scales derived from categorization of sets. These provide the teacher negative instances to incorporate into instruction for the purpose of highlighting important characteristics of the ratio scales.

The purpose of the next section is to identify some trouble spots in instruction concerning measure and measurement. The instructional problems identified are all concerned with ratio scales, in recognition of the pervasive character and importance of ratio scales. The fact that metric measure is ratio-scale measure attests to the importance of their limitation. Although the discussion of many of the problems is specific to a single measure context, generally the

discussion may be extended to any ratio-scale context.

### Specific instructional problems

Children have difficulty incorporating the idea of unit into their cognitive schemata for measure (Montgomery 1972). Precise information concerning the difficulties with the idea of unit is far from comprehensive—more basic research concerning children's development of the unit concept is needed. There is some evidence that children benefit from early, extensive experience with unit-domain elements for a given measure function *before* emphasis is placed on the fact that the measure function maps the domain element to one. Aman's article, which appeared in the April 1974 *Arithmetic Teacher*, concerns geoboards and the area function; it demonstrates an approach emphasizing the unit as providing a base for covering an area before stressing the map to the range element 1. Note that this approach can also build to the Archimedian subconcept, and with the incorporation of counting activities, it can build to a child's acquiring a sense that each domain element maps to a number. Comparable manipulative activities are readily invented for linear and angular measure. The child has experiences within the context of the physical world and acquires a manipulative base for the homomorphic operations with the range of the function.

The child's progress toward acquiring a concept of unit has been shown to be improved if the instructional strategy encompasses examination of two measure systems that possess unit-domain elements. Montgomery has stated that children's understanding a unit length is enhanced by experience with area units and vice versa. She has also demonstrated that children can acquire this subconcept as early as grade 2.

The payoff of examining with children two measure systems possessing units suggests there might also be an advantage in

comparing measure systems that are not alike in the sense of one not possessing a unit. Research indicates the benefits of positive and negative instances for concepts being incorporated into instructional sequences (Shumway 1973), but how many curricula ask children to compare measurement systems, such as Mohs' hardness scale, which lacks a unit element in the domain space, to other measure systems, such as area? Shouldn't learners explore what characteristics of a measure function are a result of its possessing a unit?

One characteristic of the unit within the context of measure functions is more scientific than mathematical: the arbitrary nature of selection of the unit. The selection of kilometers to measure the distance between Chicago and Chattanooga is a matter of judgment. Selection of a unit does possess an affective component: an automobile engine with a 2000-cubic-centimeter displacement may be more appealing than an engine with a 2-liter displacement. Judgment of convenience is required and this judgment depends on many diverse factors, but how does a learner acquire this judgment? Arbitrariness in itself is a concept requiring some maturity and sophistication. It may well be that the cumbersome calculations within the English system have helped learners realize the arbitrary character of units. With the convenience of changing units within the metric system, will children lose some perception of the arbitrary nature of unit selection?

A basic property of most measure systems discussed heretofore has been the additivity property. For a measure function  $m$  mapping from a domain of elements  $d_i$  to a range space, we can write:

$$m(d_i \cup d_j) = m(d_i) + m(d_j)$$

where

$$d_i \cap d_j = \phi.$$

The essential intuitive concept that children must acquire before dealing with the number concept is the conservation of the whole,  $d_i \cup d_j$ , on subdivision into parts. A

child must accept, for example, that a line segment will cover as much of another line as the segment broken into two or more pieces. The typical child of kindergarten age does not readily conserve in this sense, whatever the measure function. The best operational strategy for helping the child appears to be simply to give him considerable experience with conservation situations. Some teachers attempt to protect the young child from conservation situations, arguing that he is not ready, since he cannot function correctly. This is an error in judgment for two reasons. First, it is futile; the child encounters many conservation situations that are outside of the teacher's control. Second, experience within the conservation, or, in measure-function terms, additivity, context is necessary for the eventual acquisition of the concept. Piagetian psychology argues for the necessity of experience; readiness as a limitation is more of a condition determining when the child should be held responsible for producing and using the concept.

The child needs to manipulate situations requiring conservation and have the opportunity to test his perceptions. The child probably does not have adequate control of conservation until his thinking matures to the point that he can operate in contexts requiring complementation or, in the range space of the measure function, subtraction. That is, in handling area on a geoboard, if the child is to find the area of the shaded triangle in figure 19, then he looks at the

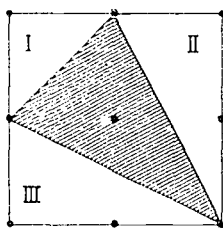

Fig. 19

square as a universe and realizes that the triangle is the complement of the union of the three triangles labelled I, II, and III. Here the computational advantage in the

range space is, of course, clear, but the maturity of handling conservation in this "subtractive" or complementation form in the domain space is a clear indication of the capability of the child to use conservation in his reasoning within measure systems.

Additivity and congruence, the two conservation subconcepts for a measure function, are factors in almost any learning concerning measure. The unit concept depends directly on the child possessing a feel for congruence. To measure the width of a desk by determining the number of paper clips that can be laid end to end across the desk requires that the child have congruence under control. Moreover, additivity's relation to conservation on subdivision into parts is the fundamental psychological tie between the manipulative, physical world and the mathematical model world of computation. As such, these two primitive subconcepts for measure functions are psychologically among the more important elements of the child's intuitive base for measurement.

Children apparently have more difficulty in gaining control of the ideas of comparison than in using units in measurement. Developmental psychologists have found, for example, considerable difference in the ages at which a child can function in particular measure systems; the child may be able to compare lengths up to two years before he can accurately compare mass. The conceptual area of comparison appears to be complicated by the child's need for words to express the comparison relations. Relational words and phrases such as "bigger than," "less," "more than," and "not as large as" are more difficult to learn than those that name objects. Many developmental psychologists have observed that the language factor is confusing and interferes with their attempt to design experiments and tests to ascertain precisely how children acquire control of comparison.

Some distinct problems with which learners must cope on the path to a mature understanding of comparison have been

found. One striking difficulty is the comparison of objects that are separated; the child goes through a phase in which two objects in close proximity can be compared correctly, but the same two objects, when separated by distance or a visual barrier, present the child with an inordinate amount of difficulty. This is analogous psychologically to the mathematical situation of moving from measuring length on one line to measuring length on different lines; the child must apparently create a mechanism for comparing each of the objects to a third standard. The accurate comparison in both situations (with two objects together and separated) proceeds without any assignment of number or employment of a measure function. The child progresses through a stage of rudimentary covering similar to a primitive use of unit in which one object is compared directly to another. If more than one dimension is involved—for example, width and length in comparing the size of rectangular regions—the child consistently fixates on a single dimension before maturing to comparison on a more appropriate basis. To date, no instructional strategy other than repeated experiences followed by routine evaluation of the accuracy of the comparison appears to correct this difficulty.

Another distinct difficulty of the child is building inferential capability into his system for comparison. Acquisition of the transitive property for measure systems comes later than the pairwise comparison but offers the child a portion of the reasoning base that he needs. Seriation or the capability for ordering a finite set of objects by size further extends the capability of the child in dealing with comparison.

Learning situations for comparison seem to automatically include consideration of the subconcepts related to conservation. Asking a child to compare two sheets of paper, *A* and *B*, by placing one on the other, as in figure 20, and at the same time to ignore the uncovered portion of *B* is difficult. Indeed, the child's attention should

be focused on the uncovered portion. For pairwise comparison, experience with additivity's base of conservation is inescapably given, and congruence inextricably appears as part of the experience of the child in using a third unit for comparison of two objects.

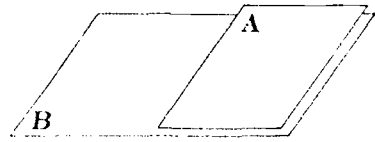

Fig. 20

The Piagetian model of how children develop geometrical concepts identifies the important intuitive components of the physical, manipulative base for the measure functions. Although our discussion has been general in the sense that it has cut across different ratio-scale measure functions, each of the primitive subconcepts has played a role in the examples given. The Piagetian model identifies psychological analogues for each of the subconcepts.

The emphasis on Piagetian psychology is not all that helpful to the teacher in many respects. It does not, for instance, specify a best sequence for children's curricular encounters with ideas. Indeed, it is difficult to specify a sequence, since the concepts are so intertwined. It does, however, strongly affirm that readiness is a factor in teaching measure. First, measure for any characteristic function is a system, a structure of subconcepts. Consequently, it should be noted that system ideas are characteristic of mature learners in Piaget's model. If you accept his model for conceptual development, then you should expect control of a particular measure function to come at the upper elementary or junior high school ages.

Second, the particular primitive subconcepts will come earlier, before the child has a grasp of the total system of the function. This means that experiences with each subconcept must be a part of children's



geometrical experience early in their mathematics instruction. The Piagetian model of development entails strong implications for instruction in terms of readiness. The implication is that children *must* be provided opportunities for manipulative experience with each primitive subconcept within a variety of measure functions. Conservation or additivity should be examined for length, volume, area, time, and mass. Rate and force, as well as length, area, and volume, should be used as contexts for exploratory experiences in comparison. The idea of a unit should be exploited as a source of activities for children in a variety of measurement contexts; otherwise the child will never be ready for the totality of the measure-function system of concepts. Rather than readiness providing an argument against curricular experience in the case of measure, it provides a strong brief for extensive experience with a wide variety of activities.

Third, readiness considerations indicate that computational facility for the measure functions is at a late stage in the learner's evolution of measure ideas. Computation is a system or structure idea. The child must have some understanding of operations and relations within both the domain space and the range space and, most importantly, of the functional connection between the two.

The child's coping with measure concepts in school is not limited to activities that are designed to teach measure. Activity-oriented and manipulative-based materials designed to teach computational concepts and skills probably constitute the majority of the child's experiences with measure concepts in most classrooms. Developing addition and subtraction facts on the number line (see fig. 21) is an effective means of building conservation and

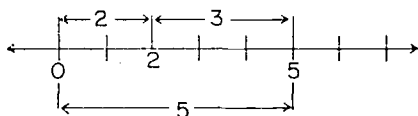

Fig. 21

the additivity properties needed for facility in measure. To use the rectangular array to develop the multiplication fact of  $2 \times 3 = 6$ , as shown in figure 22, requires

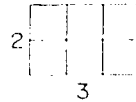

Fig. 22

the child to count squares and provides some feeling for units. To ask a child to use a number line to find how many 3s are in 29 informally develops an awareness of the Archimedian property. (See fig. 23.)

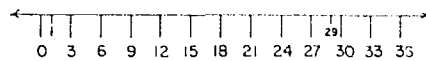

Fig. 23

The teacher should recognize that providing children with these measure experiences is sound pedagogy for building concepts of measure. Albeit informal, in that teaching measure concepts is not the explicit primary objective of such lessons, these secondary objectives provide an important component of instructional planning of which the teacher should be aware as the primary goal of computational instruction is addressed.

There are, of course, two ever-present dangers of which the teacher should be aware. First, the teacher must not rely exclusively on physical models or objects for computational objectives if those models rely on measure concepts to make them work. Multiple embodiments of the concepts give children different bases for acquiring the concepts depending on their aptitudes, interests, and abilities. A variety of types of models, some of which are developed on a nonmeasure base, are needed by those children who do not yet have full control of measure ideas. Discrete counting activities for establishing addition facts supplant the use of the number line for the child who does not yet

possess a full concept of length (see fig. 24), but the teacher should use the number-line activity as well as the discrete model, since it provides an important assimilatory base for the conservation concept. As such, the teacher is providing a good intuitive foundation for both addition and measurement.

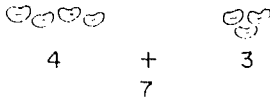

Fig. 24

Second, if the teacher is not careful in the selection of models for computation, then the teacher risks establishing either proactive or retroactive interference with learning; that is, learning can interfere with learning yet to come or can cause forgetting of something learned previously. The take-away model for subtraction might be used to establish the fact  $12 - 8 = 4$  by exhibiting a ruler and breaking off four units to throw away, as in figure 25. For the child who as yet does not

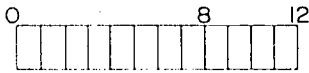

Fig. 25

possess the conservation concept, an interference with his acquiring it may be established. Or consider the case of the student who possesses a fairly firm grasp of the primitive subconcept of units; her teacher approaches multiplication of fractions thusly:  $3/4 \times 2/5$  means you find  $2/5$  of

a unit and then  $3/4$  of what is left. A drawing like that in figure 26 is exhibited on the chalkboard. It is modified as indicated, with an accompanying dialogue indicating that at *A* the square is a unit, a whole out of which we want  $2/5$ . When we get the  $2/5$  at stage *C*, we know what to do—simply look at the rectangle as a whole unit (like we did at *A*) and take  $3/4$  of it. Many teachers then return to the original unit and use one of the small rectangles of stage *E* as a unit to cover the original square *A*. Eventually, this yields the desired  $6/20$ . Clearly, the “of” approach or model of multiplication of fractions leaves something to be desired. For the student who does not have the unit concept under control, this is particularly true. In all likelihood, a proactive interference is established between learning about units of measure in the context of fractions and the instruction in which measure is the primary objective. Parenthetically, it might be noted that the “of” approach to multiplication of fractions has been the favored approach in elementary school texts.

Texts contain many sections devoting exclusive attention to objectives concerning measure, but the incidental learning concerning measure, which accompanies instruction directed to objectives, should not be ignored by teachers and curriculum developers. Potential for this incidental learning depends on the selection of the models or physical situations that provide the embodiment for the number concepts. The extent to which such incidental learning can be and should be relied on as a significant component of a child's experience with measure is an open question. Clearly, such activities cannot be relied on exclusively as the means to teach

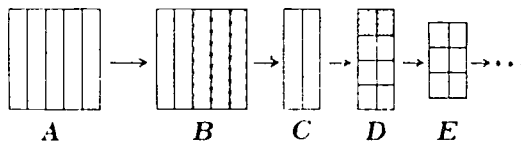

Fig. 26

measure; specific activities and lessons on measure are necessary. However, research appears to indicate unequivocally that multiple embodiments of numerical concepts are preferred, since not all children have sufficient grasp of measure concepts. This is to say, any instructional program for computation that makes exclusive use of the number line should be viewed with extreme suspicion.

This section has been concerned with some of the psychological problems of teaching and learning about measure concepts. Primarily, it has addressed the task of building intuitions for measure in the clean, pure world of the mathematical model. The problems of learners with the measuring skills and approximation judgments have not been considered.

#### **Metrication and the teaching of measure**

What are the implications of converting to the metric system for the teaching of measure concepts? Will acquiring the processes and skills of measurement be affected by the metrication of school mathematics and science materials? These questions are uppermost in the minds of many teachers of junior high and elementary school children today.

The questions are significant. Clearly, text publishers have begun the shift to a metric base for instruction in school science and mathematics. Materials based on the metric system are becoming readily available to the teacher, so, for the most part, material availability is not at issue. (It is perhaps an issue in some locations, depending on the availability of funds for instructional materials.)

The preceding sections have focused on instruction in measure rather than measurement. The use of the word *measure* was reserved for the mathematical-model components of instruction. The word *measurement* was restricted to processes, skills, and ideas in the real world of practical and scientific use. The emphasis has been on the mathematical structures within

the mathematical models; the functions that characterize the measures for the models provide the skeleton of instructional objectives and establish the transfer potential for measure systems. The discussions have been independent of particular measurement systems; for instance, discussion of the area function does not depend on the measurement system being English or metric, but it would be quite hasty and misleading to state that metrication has little or no implication for the teaching of measure concepts or that conversion will have small impact on instruction for the mathematical-model ideas. Some representative implications are discussed below.

1. *Children need to develop metric intuitions.* Children learn measure concepts in the environment of the real world. Language, tools of measure, gross estimates of magnitude, and the like are the "stuff" of instruction. The child needs perceptual bases for learning, because meaningful experiences stem partly from familiarity with the perceptual environment. If the child has no feeling for whether twenty-five degrees Celsius is cold or hot, the child does not have available one (of many) stimuli when he learns about temperature scales. The larger the number of familiar stimuli, the more likely the child will enjoy meaningful learning. The teacher who wants to capitalize on the motivational potential of children's enchantment with the very large and the very small cannot presume children's familiarity with metric measurements if the children have had little experience in the use of the metric system. In short, the particular measurement system used in instruction, along with its vocabulary and tools, provide the environmental components the teacher uses. Temporarily, at least while the country is in the process of conversion, metric usage will not be a component of many children's away-from-school experiences. Consequently, the teacher must supplement and extend children's experiences

with the metric world. In terms of assuring success in teaching measure concepts, providing extensive opportunities for building metric intuitions is one of the most significant strategies a teacher can follow.

2. *Children need to acquire a usable understanding and computational facility with decimal fractions.* The payoff of metrication for most individuals will be the ease of conversion from one measurement scale to another, but understanding of the conversion process is possible only with understanding of decimal fractions. It is tempting to advocate earlier encounters with decimals for children; certainly the acquisition of understanding of decimals at an earlier age would facilitate instruction, but this requires that researchers and curriculum developers in mathematics explore questions of the scope and sequence of children's experiences with decimals. The instructional sequences most commonly used develop the mathematics of decimal fractions from children's understandings of common fractions. Exploratory evaluations of curricula that move directly from whole-number concepts or integer concepts to decimal fractions without the intervening stages of common-fraction instruction need to be conducted. In short, understanding of decimals has assumed greater importance as a goal in school mathematics.

3. *The metrication of American schools and society does not decrease the importance of children's acquiring concepts and skills for nondecimal fractions.* Children need to acquire a basic understanding of rational numbers in all their forms in order to cope with important mathematical ideas. As with the decimal-fraction curriculum of the previous implication, there are significant questions concerning the sequencing of children's encounters with rational numbers that need exploration. It may well be that instructional emphasis on common fractions should be delayed until after decimal-fraction understandings are acquired.

4. *Metrication should allow teachers the freedom to include more and better measurement activities in instructional plans.* Children have needed extensive experience in conversion within the English system because of the complexities of computation with common fractions. Without the distraction of this computational level, teachers should be able to direct instruction to the powerful concepts of measure more frequently. Although most authorities agreed that careful attention to the fundamentals of measure paid off in the increased achievement of students, they found—and teachers agreed—that specific instruction on conversion was necessary when teaching the English system. Conversion within the metric system will not be a distraction and instead will reinforce basic concepts of numeration. Conversion between the English and metric systems will rarely be necessary except for a few technicians and should not be emphasized in the school curriculum. It should be noted that the foundational decisions of convenience of the scale or unit need special attention. The fundamental ideas of the ratio-scale transformations of dilation and translation, along with the concomitant outcome of ratio invariance, have never received the attention they deserved at the secondary school level. Removal of computational distractions should provide teachers with the opportunity to reorder their priorities in planning instruction.

5. *Children need to apply measure concepts and measurement processes to a variety of problems involving the metric system.* Convincing children of the efficacy and efficiency of the metric system is perhaps best accomplished through the use of the metric system in "real" situations. Rather than a frontal, tiresome assault on the components of metric measurement, a balanced program of direct instruction and frequent application of the ideas and skills in realistic problem situations is the best strategy. The use factor has been found highly motivating by many teachers. Use

provides the argument for the importance of the metric system. Max Bell's *Mathematical Uses and Models in Our Everyday World* (1972) provides numerous and diverse examples of different types of measure problems that teachers and students can find in observing the world around them. Repeated attention to the categories of problems represented in the Bell book strengthen problem-solving skills, build familiarity with metric measurement, and provide for a strong general education component of a child's experience with measure.

In conclusion, we reaffirm the theme stated in the beginning: teachers should not make a fuss about metrication. Metrication is reasonable and rational; teachers should not lead children to anticipate non-existent difficulties. Teachers and curriculum developers can take advantage of the move to metrication to reconsider and redirect the nature of instruction in measure concepts and measurement processes. This redirection should encompass building intuitions for the functional and homomorphic character of measure.

### Bibliography

- Allendoerfer, Carl B. "The Nature of Mathematics." In *Mathematics in Elementary Education*, edited by N. J. Vigilante. London: Collier-Macmillan, 1969.
- Aman, George. "Discovery on a Geoboard." *Arithmetic Teacher* 21 (April 1974): 267-72.
- Bell, Max S. *Mathematical Uses and Models in Our Everyday World*. Studies in Mathematics, vol. 20. Stanford, Calif.: School Mathematics Study Group, 1972.
- Blakers, A. L. *Mathematical Concepts of Elementary Measurement*. Studies in Mathematics, vol. 17. Stanford, Calif.: School Mathematics Study Group, 1967.
- Boorstin, Daniel J. *The Americans: The Democratic Experience*. New York: Random House, 1973.
- Bridgman, Percy W. *The Logic of Modern Physics*. New York: Macmillan Co., 1938.
- Churchman, C. W., and P. Ratoosh, eds. *Measurement: Definitions and Theories*. New York: John Wiley & Sons, 1959.
- De Simone, Daniel V. *A Metric America: A Decision Whose Time Has Come*. U. S. Metric Study. Washington, D.C.: Government Printing Office, 1971.
- Eddington, Arthur S. *The Philosophy of Physical Science*. New York: Macmillan Co., 1939.
- Klopfer, L. E. "Evaluation of Learning in Science." In *Handbook on Formative and Summative Evaluation*, edited by Benjamin S. Bloom, et al. New York: McGraw-Hill Book Co., 1971.
- Lovell, Kenneth. "Some Studies Involving Spatial Ideas." In *Piagetian Cognitive-Development Research and Mathematical Education*, edited by Myron F. Rosskopf, Leslie P. Steffe, and Stanley Taback. Washington, D.C.: National Council of Teachers of Mathematics, 1971.
- McShane, E. J., and Truman A. Bots. *Real Analysis*. Princeton, N. J.: Van Nostrand Reinhold Co., 1959.
- Moise, Edwin E. *Elementary Geometry from an Advanced Standpoint*. Reading, Mass.: Addison-Wesley Publishing Co., 1963.
- Montgomery, Mary E. *The Interaction of Three Levels of Aptitude Determined by a Teach-Test Procedure with Two Treatments Related to Area*. Report from the Project on Development of Instructional Programs: Analysis of Mathematics Instruction. Madison, Wis.: Research and Development Center for Cognitive Learning, 1972.
- Piaget, Jean, and Barbel Inhelder. *The Child's Conception of Space*. London: Routledge & Kegan Paul, 1956.
- Piaget, Jean, Barbel Inhelder and Alina Szeminska. *The Child's Conception of Geometry*. London: Routledge & Kegan Paul, 1960.
- Shumway, Richard J. "Negative Instances and Mathematical Concept Acquisition." *Theory into Practice* 12 (December 1973): 307-15.
- Sinclair, Hermine. "Number and Measurement." In *Piagetian Cognitive-Development Research and Mathematical Education*, edited by Myron F. Rosskopf, Leslie P. Steffe, and Stanley Taback. Washington, D.C.: National Council of Teachers of Mathematics, 1971.
- Skemp, R. *The Psychology of Learning Mathematics*. Middlesex, England: Penguin Books, 1971.
- Smedslund, J. "Development of Concrete Transitivity of Length in Children." *Child Development* 34 (1963): 389-405.
- Steffe, Leslie P., and L. Ray Carey. "Before Children Can Measure." *The Elementary School Journal* 63 (1971): 286-92.
- U.S. Congress, Senate. *Congressional Record*, 93d Cong., 1st sess., 1973, vol. 119, p. 2:145. S: 100.