



LUND UNIVERSITY

A model for fracture analysis

Hillerborg, Arne

1978

[Link to publication](#)

Citation for published version (APA):

Hillerborg, A. (1978). *A model for fracture analysis*. (Report TVBM; Vol. 3005). Division of Building Materials, LTH, Lund University.

Total number of authors:

1

General rights

Unless other specific re-use rights are stated the following general rights apply:

Copyright and moral rights for the publications made accessible in the public portal are retained by the authors and/or other copyright owners and it is a condition of accessing publications that users recognise and abide by the legal requirements associated with these rights.

- Users may download and print one copy of any publication from the public portal for the purpose of private study or research.
- You may not further distribute the material or use it for any profit-making activity or commercial gain
- You may freely distribute the URL identifying the publication in the public portal

Read more about Creative commons licenses: <https://creativecommons.org/licenses/>

Take down policy

If you believe that this document breaches copyright please contact us providing details, and we will remove access to the work immediately and investigate your claim.

LUND UNIVERSITY

PO Box 117
221 00 Lund
+46 46-222 00 00

DIVISION OF BUILDING MATERIALS
THE LUND INSTITUTE OF TECHNOLOGY

A MODEL FOR FRACTURE ANALYSIS

ARNE HILLERBORG

REPORT TVBM-3005
LUND SWEDEN 1978

A MODEL FOR FRACTURE ANALYSIS

ARNE HILLERBORG

PREFACE

At the Division of Building Materials, Lund Institute of Technology, work has been in progress since 1975 on the practical application of fracture mechanics to building materials and building structures.

In the course of this work a new model for fracture behaviour was developed. The model has thus far been described in two Swedish publications /1, 2/ and a special application described in an English journal /3/. In the present report, the model is briefly described, its applicability discussed, and general conclusions drawn.

Applications other than the example provided in /3/ will be presented in the near future.

1. Proposed general model

We ordinarily consider the tensile fracture of a homogenous bar and that of a notched or cracked bar to be different types of phenomena. The former is described by the theory of strength of materials, and the latter by fracture mechanics.

The model proposed below describes all cases of fracture although some essential parameters may depend on the type of fracture studied.

The model is based on the following assumptions, cf Fig 1.

1. When a tensile stress σ starts increasing from zero, the stress result in a strain ϵ , governed by a σ - ϵ curve. In two- and three-dimensional cases, stresses and strains in other directions influence the response, but the principal idea does not change.
2. The σ - ϵ curve is valid only until a limiting strain ϵ_ℓ is reached. The corresponding value of σ is the tensile strength f_t . ϵ_ℓ and f_t may depend on stresses and strains in perpendicular directions.
3. When the deformation exceeds that corresponding to ϵ_ℓ a fracture zone starts to develop and the stress σ starts to decrease.

Any additional elongation is concentrated in the fracture zone, whereas in adjacent parts of the material stress and strain decrease. Within the fracture zone the displacement above that corresponding to the σ - ϵ curve is denoted by w . σ is related to w by a σ - w curve.

4. The fracture zone is assumed to have an original length of zero in the direction of the main tensile stress and a length of w after the zone has begun to develop. The fracture zone thus may be visualised as a fictitious crack, able to transfer tensile stresses σ . The tensile stress is a function of the fictitious crack width w according to a σ - w curve.

We thus need two curves to describe the deformation characteristics of a material: one for σ - ϵ when $\epsilon \leq \epsilon_\ell$, and another for σ - w when $\epsilon > \epsilon_\ell$, Fig 1.

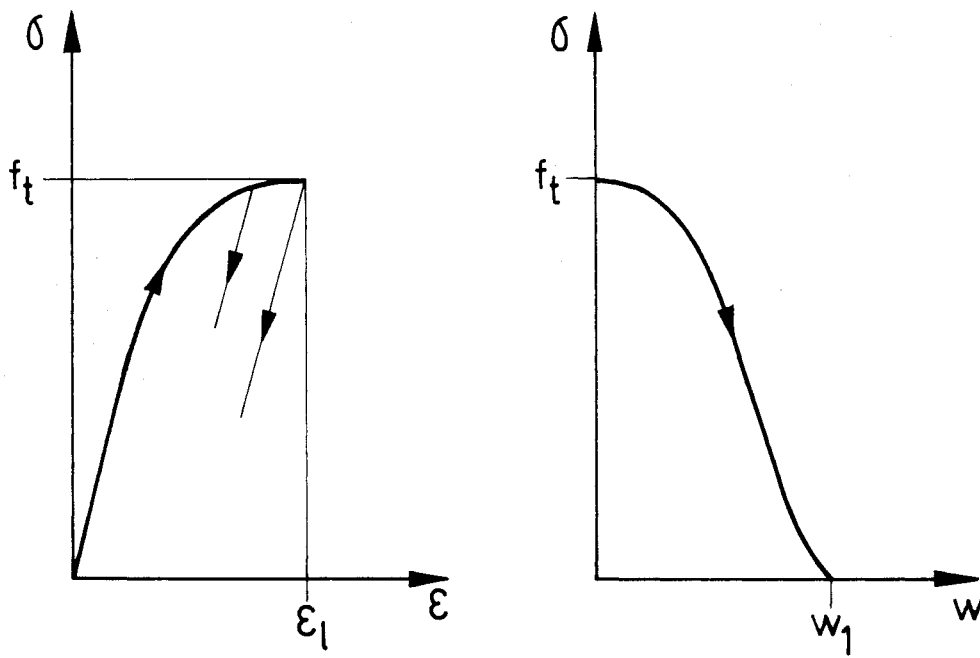
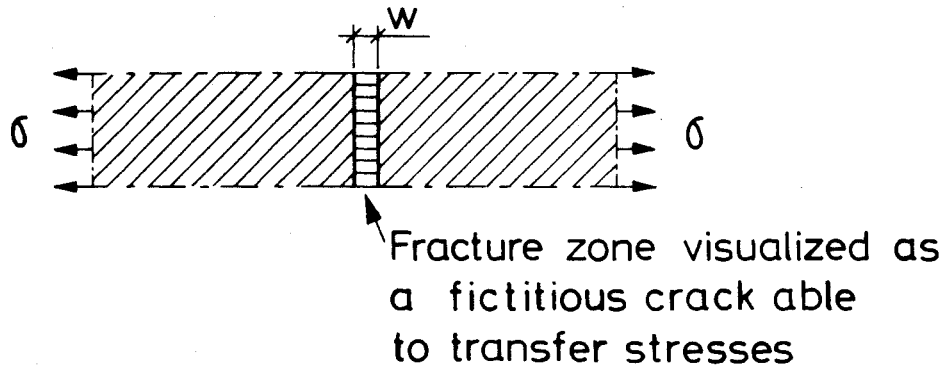

Fig. 1 Main characteristics of the proposed model

2. Application to a tension test of a steel bar

We apply our model to a tension test of a steel bar of uniform section, Fig 2 to study the total elongation Δl along two equal gauge lengths l . The actual behaviour of the steel bar at fracture as well as that represented by the model are shown in Fig 2.

As long as the strain ϵ nowhere exceeds ϵ_λ , the bar will be subject to a uniform strain ϵ governed by the σ - ϵ curve.

The total elongations Δl_A and Δl_B are thus equal and follow the expression

$$\Delta l_A = \Delta l_B = \epsilon l$$

When ϵ exceeds ϵ_λ at a point, a fracture zone begins to develop at that point and the stress begins to decrease according to the σ - w curve. As the stress σ decreases the strain ϵ will also decrease everywhere outside the fracture zone. Thus ϵ_λ will never be exceeded anywhere other than within the fracture zone and only one fracture zone will develop.

If we assume that the fracture zone is located within the gauge length A, the elongation may be written

$$\Delta l_A = \epsilon l + w$$

$$\Delta l_B = \epsilon l$$

where ϵ is determined by an unloading branch of the curve.

We can summarize the expressions for the deformation of a gauge length l as follows:

If no fracture zone exists within the gauge length

$$\Delta l = \epsilon l \tag{1}$$

If a fracture zone does exist within the gauge length

$$\Delta l = \epsilon l + w \tag{2}$$

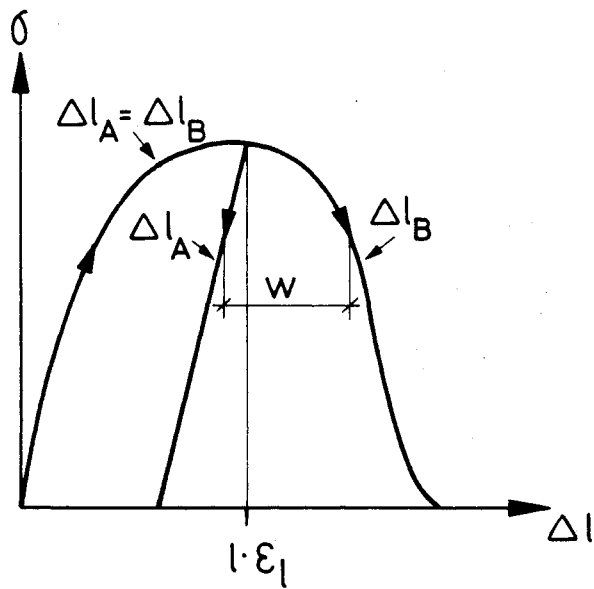
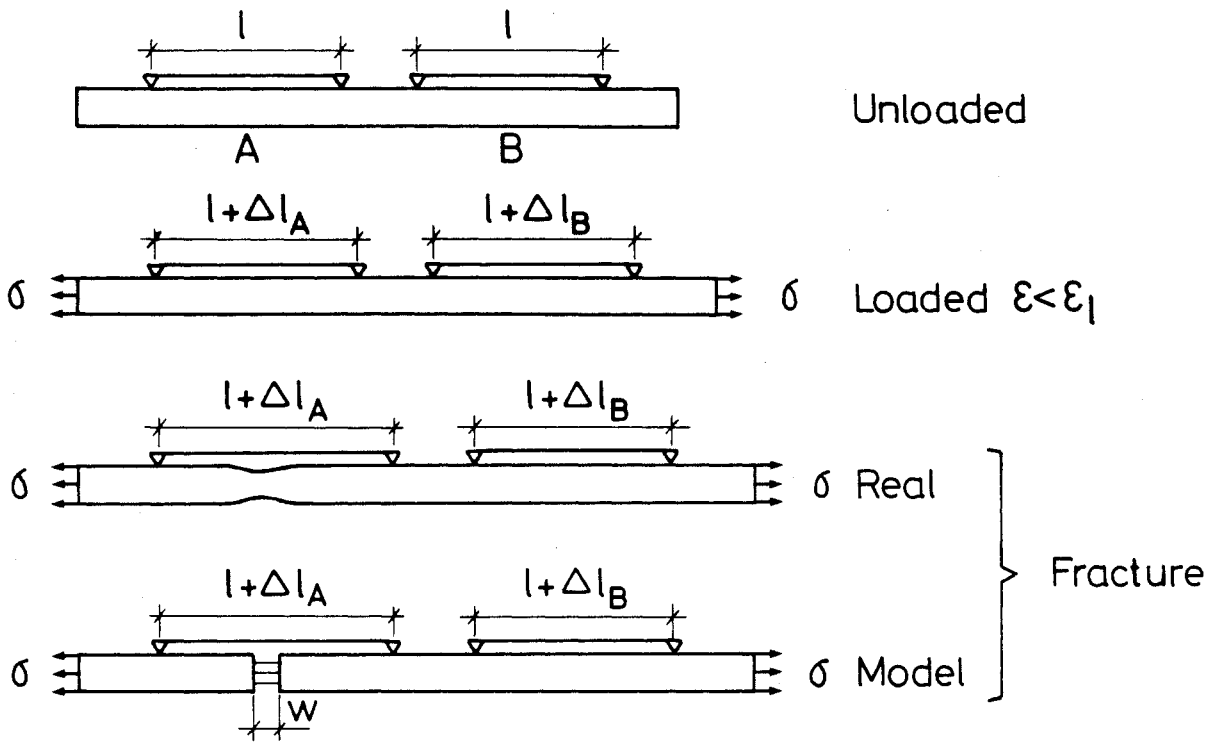

Fig. 2 Deformations in a tension test

3. Application to crack propagation

The application of the model to the case of crack propagation will be demonstrated for mode I, the opening mode, only. The application to other modes is similar.

In a specimen with a crack and tensile stress as in Fig 3, there will be a stress concentration at the crack tip, which, according to the theory of elasticity, is infinitely large. Thus the strain will exceed ϵ_{ℓ} just in front of the crack tip as soon as a stress is applied and a fracture zone will develop in front of the crack tip.

We can visualize the fracture zone as a fictitious crack, able to transfer stresses σ which depend on the fictitious crack width w .

At the fictitious crack tip $\epsilon = \epsilon_{\ell}$ and $\sigma = f_t$. The fictitious crack tip is a limit between the zone where σ depends on ϵ and the zone where σ depends on w .

As the force increases, the fictitious crack increases in length and width. When the width w reaches a limiting value w_1 (Fig 1), the stress at that point disappears and an actual crack propagates.

The development of the fracture zone and the crack can thus be traced from the first application of a stress to final rupture.

4. Application to bending of an uncracked beam

When we apply a bending moment M to an uncracked beam, the strains and stresses will at first increase according to the σ - ϵ -curve, cf Fig 4.

As M reaches a value M_{ℓ} the tensile strain reaches ϵ_{ℓ} at the bottom of the beam. If M is further increased, ϵ_{ℓ} will be exceeded and one or more fracture zones will develop. Within the fracture zones the stress σ decreases as the fictitious crack width w increases. Thus no new fracture zone can develop close to an already developed fracture zone. As $M > M_{\ell}$, several fracture zones may develop, but in

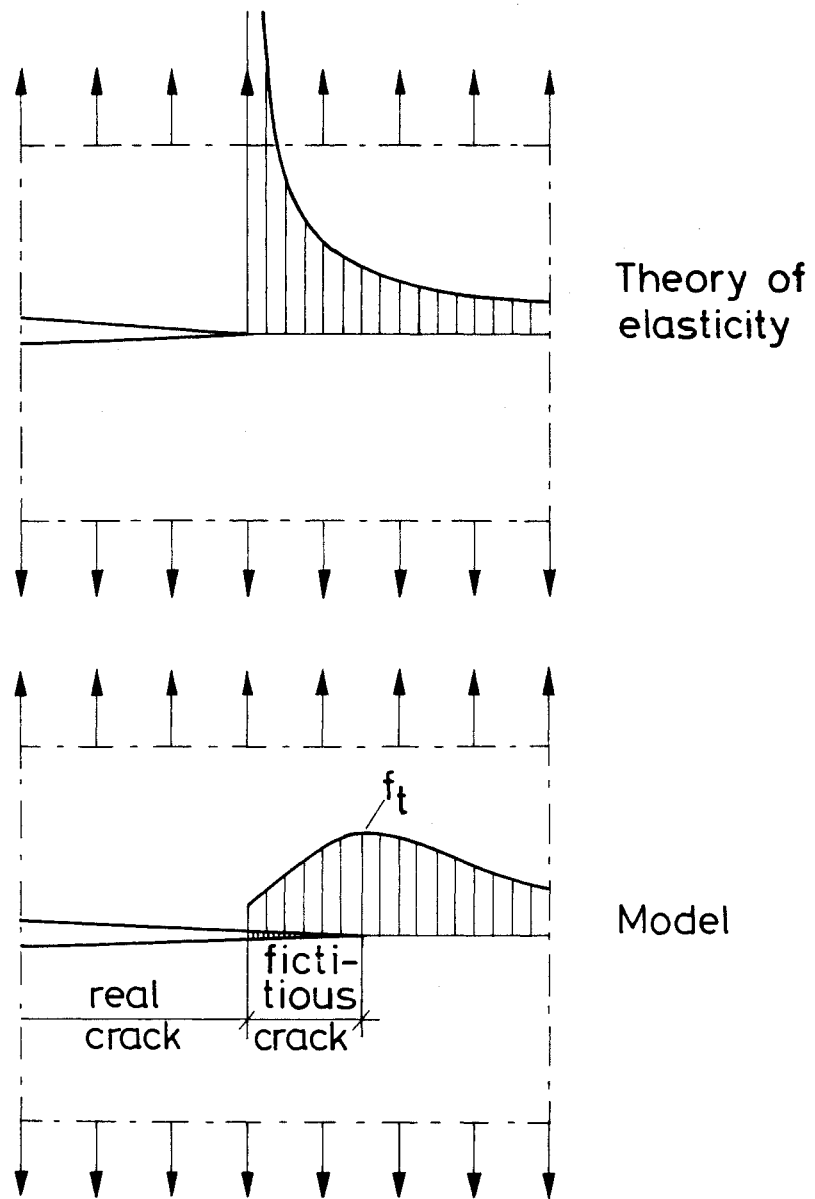

Fig. 3 Stresses in front of a crack tip

discreet sections. When the load is increased, the deformation w of the fracture zones increases, while the bottom strain ϵ between these zones decreases. A non-uniform strain along the bottom and a non-linear strain distribution over the depth of the beam results.

As the load M increases, the length and width of the fracture zones increase, until actual cracks develop and finally rupture occurs.

The complete behaviour of a beam under the action of increasing loads or superimposed deformations has thus been described through the uncracked stage, the development of fracture zones and the development and propagation of cracks until rupture occurs. The model thus covers the theory of strength of materials as well as fracture mechanics and all stages between these two.

5. Conclusions regarding model laws

If two specimens of similar shape but different size are made of the same material and are identically loaded, stresses and strains will be identical at corresponding points as long as the limit strain ϵ_{ℓ} is not exceeded anywhere. Model laws can thus be applied.

Suppose that the load is increased until ϵ_{ℓ} is exceeded and fracture zones develop, but stresses and strains remain fully similar. At corresponding points in the specimens, σ values will be identical, but the lengths of the fracture zones and w values will be proportional to specimen size.

The fracture stage, i.e. after ϵ_{ℓ} has been exceeded, thus will be fully similar only if the σ - w -curves for the specimens differ so that the w value corresponding to a given σ -value is proportional to specimen size.

The model laws thus do not apply to the fracture stage of specimens made from the same material, but of different size.

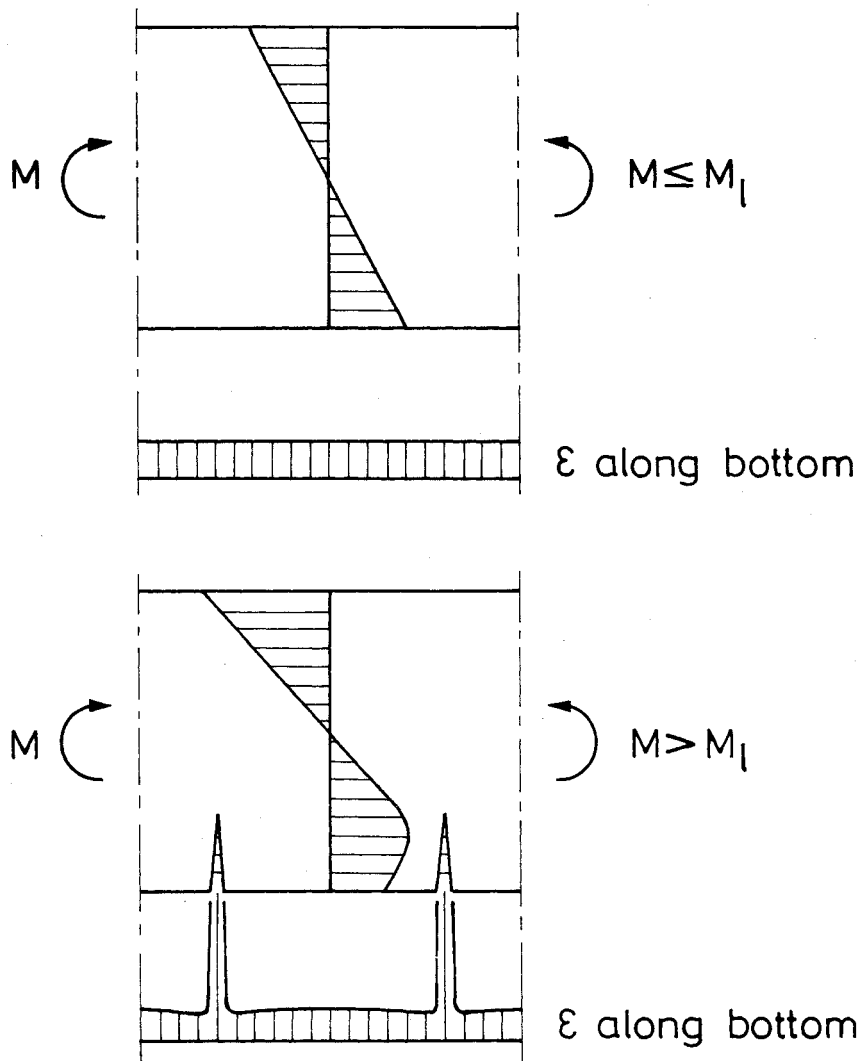

Fig. 4 Strain distribution before and after fracture zones have developed in a bent beam

Especially for materials that fail due to stress-induced cracking, such as reinforced concrete beams failing in shear, this is a very serious conclusion. In such cases large specimens ought not to be designed using formulas derived from tests of small specimens of the same material, as the model laws may not be applied. A large specimen will be less strong than predicted from tests of small specimens, as σ in the fracture zone of the large specimen will decrease more rapidly due to the greater w -value.

Results of numerical calculations based on the proposed model for beams in bending /3/ show that the bending strength of concrete, treated as an elastic material, is higher than the tensile strength and increases with decreasing depth.

6. The σ - w -curve

When the width w of the fracture zone is increased by an increment dw , an amount of energy equal to σdw is absorbed per unit area of the fracture zone.

In fracture mechanics the energy absorbed in forming one unit area of crack is denoted by G_C . With our notation this is the total energy when w passes from zero to w_1 , thus

$$\int_0^{w_1} \sigma dw = G_C \quad (3)$$

The area below the σ - w -curve is thus equal to G_C , Fig 5. Eq (3) links the proposed model and classical fracture mechanics.

For some materials the shape of the σ - w -curve strongly depends on the specimen type, size etc, especially for materials such as mild steel and other metals that yield in shear before final fracture. It is wellknown that G_C for such materials varies for example with the width of a notched beam. For such materials G_C for a pure tension test is much higher than that for a test on a notched beam and increases with increasing bar diameter.

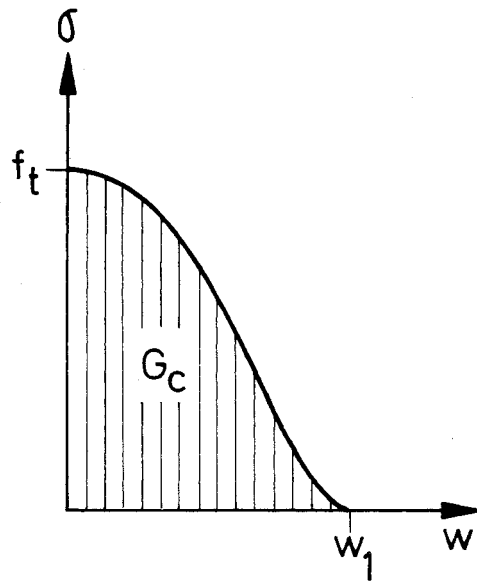

Fig. 5 The area below the σ - w -curve is identical to the energy absorption G_c used in fracture mechanics

For materials that do not yield in tension - such as concrete, glass, ceramics and many organic materials - it is reasonable to assume that the σ - w -curve is a property typical of the material and does not strongly depend on specimen type. Thus for these materials the same σ - w -curve (and the same G_c -value) may be used to study pure tension, bending in unnotched beams, and crack propagation.

7. Comparison with classical fracture mechanics

As has been pointed out above the proposed model is linked to classical fracture mechanics by means of Eq (3). The proposed model and classical fracture mechanics are thus not incompatible.

The model appears to cover most problems that can be treated by classical fracture mechanics. It is similar to other models used within fracture mechanics, e.g. that of Dugdale, which corresponds to a special case of the proposed model.

On the other hand the proposed model may serve to better explain some types of fracture behaviour.

1. Since the model is general, it may be applied to tensile fracture as well as to crack propagation and can be used to explain cracking in an originally uncracked specimen.
2. Material properties that may significantly influence fracture behaviour, but are not accounted for in classical fracture mechanics may be accounted for by the σ - w -curve. The shape of the σ - w -curve (for the same G_c) may greatly influence fracture behaviour.
3. The model is suited for numerical calculations by means of finite element methods since it assumes only finite stresses and stresses, deformations, and energy absorption are logically connected.
4. The model is easy to visualize and therefore suitable as a basis for discussing and explaining fracture phenomena.

8. Conclusions

The proposed model has the following characteristics:

1. It is general in that it can be applied to all types of fracture, e.g. ordinary tensile fracture, crack formation, and crack propagation.
2. It is clearly related to classical fracture mechanics and may be considered as an extension of established models.
3. It can account for characteristic material properties by varying the σ - w -curve.
4. It is well suited for numerical calculation, e.g. using finite elements.
5. It is easy to visualize and thus is suitable for theoretical discussion.

We have demonstrated that model laws customarily used in design may be inaccurate for fracture analysis. Many formulas used for design - e.g. these for shear of reinforced concrete - are thus unreliable for large specimens, as they are based on tests of small specimens. The proposed model enables theoretical study of these phenomena.

References

1. Petersson, P-E and Mod er, M: Brottme­kanisk modell f r ber kning av sprickutbredning i betong. Division of building technology, Lund institute of technology, Report 70, Lund, Sweden, 1976
2. Hillerborg, A: Materialbrott. Department of building materials. Lund institute of technology, Report TVBM-3004, Lund, Sweden, 1977

3. Hillerborg A, Modéer M and Petersson P-E: Analysis of crack formation and crack growth in concrete by means of fracture mechanics and finite elements. Cement and Concrete Research 6 (1976) 773