

# A MULTILEVEL MODULATION SCHEME FOR HIGH-SPEED WIRELESS INFRARED COMMUNICATIONS

*Steve Hranilovic and David A. Johns*

Department of Electrical and Computer Engineering  
University of Toronto  
10 King's College Road  
Toronto, Ontario, CANADA M5S 3G4  
Email : shranilo@eecg.utoronto.ca

## ABSTRACT

To investigate short-distance, point-to-point, infrared channels, a test-bench and circuits were constructed to determine the limitations of existing optoelectronics. The results of these measurements are used to formulate a channel model which is employed for the subsequent analysis of candidate bandwidth efficient modulation schemes. A new multilevel modulation scheme, Adaptively Biased QAM (AB-QAM), is proposed which has an asymptotic 3 dB SNR improvement over PAM and a 4.5 dB improvement over QAM for large constellations while maintaining the same bandwidth efficiency. Expressions are derived for the performance of each modulation scheme and are verified in simulation.

## 1. MOTIVATION

In recent years there has been a proliferation of portable, hand-held devices for data collection and processing. Digital cameras, palm-top computers and PDAs allow users to accumulate, access and process their data away from the desktop. Although these devices are convenient, connecting them back into the desktop environment for data exchange remains a challenge. Mechanical connectors on such devices are expensive due to their small size, and are prone to wear and breakage. RF alternatives for this short distance are also expensive and near-field effects become prevalent at present carrier frequencies. Free-space optical communications are ideally suited to this application due to the availability of low-cost components, unregulated bandwidth, compact size and the absence of physical connectors.

Commercial infrared (IR) links currently exist on these devices for data exchange at 4 Mbps, with proposals for 16 Mbps links on the horizon [1]. This paper presents the initial steps in the development of a point-to-point IR wireless link capable of providing data rates up to 1 Gbps over short distances. Such a link would provide a useful means for connecting portable devices to network and video data stores as well as to better user interface peripherals.

For this solution to be economical, low-cost optoelectronic components must be used. The goal of this paper is to present a simplified channel model of the intensity modulated channel and to present the performance of multilevel modulation schemes in this environment.

Section 2 discusses the characteristics of typical optoelectronic components as well as the results of the experimental setup constructed to view some basic channel properties. The constraints

This work was supported by the Natural Sciences and Engineering Research Council of Canada as well as by Micronet.

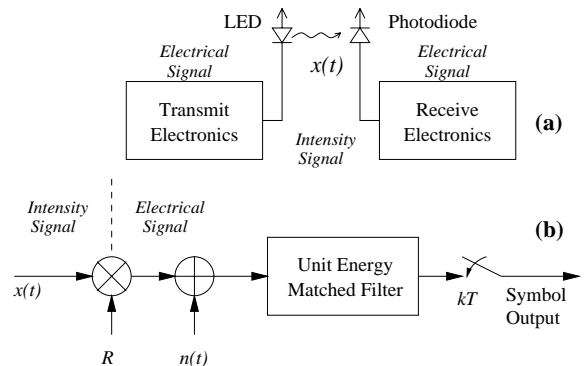

Figure 1: A simplified channel schematic (a), and model (b) used for the analysis of proposed modulation schemes.

imposed by the optical intensity modulated channel are also presented. Section 3 explores the impact of such channels on some popular modulation schemes currently in use on optical channels. The need for higher bandwidth efficiency leads naturally to the use of multilevel modulation techniques. Section 4 presents a new modulation scheme, Adaptively Biased QAM, and verifies performance claims in simulation. Section 5 presents some concluding remarks as well as directions for future work.

## 2. CHANNEL MODELLING

The first stage in the development of a high-speed link is to understand the channel characteristics. This section describes the initial steps taken to propose and extract a sufficiently accurate model for the short-distance IR link.

### 2.1. Channel Definition

The basic configuration of a free-space optical channel consists of transmit side circuits which drive a light-emitting device (e.g., an LED) and a photo-receiving device (e.g., a photodiode) with some receive side signal processing circuits (Figure 1(a)).

LEDs produce light over a relatively wide spectral range and are available at a variety of frequencies. They offer the advantages of increased reliability, greater stability, higher linearity and increased eye-safety over laser light sources. The optical intensity versus drive current for typical LEDs is a relatively linear function provided the

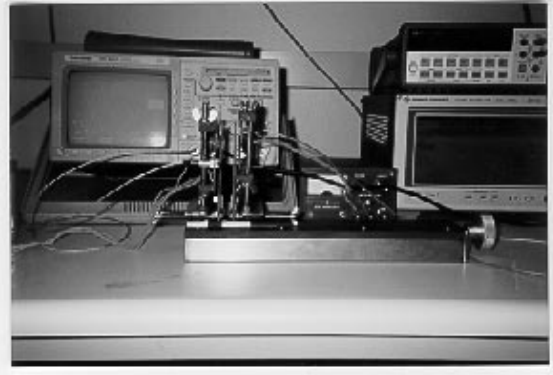

Figure 2: A photograph of the experimental setup.

current densities remain low [2].

At the receive side, the photodiode converts the optical intensity signal into a signal current. This current is produced by the generation of electron-hole pairs in the depletion layer of the device by the incident photons. These carriers are swept out by the large electric field in the region. The output current has been shown to vary linearly with the incident optical power over more than six decades of output current [2].

To characterize the physical channel, transmit side and receive side electronics were designed to drive commercial optoelectronic components. The receive and transmit circuits were produced on two custom PCBs and mounted in a custom built test fixture as shown in Figure 2. The experiments were conducted under normal background light with the distance between the transmitter and the receiver set at 1.5cm. To determine the spurious free dynamic range (SFDR) of the channel, the noise floor and the distortion products were measured. Over the bandwidth of the channel, the total noise power at the receiver output was -45 dBm. Measurements with a -35 dBm output sinusoid indicate that the second order distortion products dominate and have a power of -70 dBm. Combining these two results, and correcting for the frequency characteristics of the channel yields a SFDR measurement equal to 20 dB.

Since the amount of distortion when operating in this range is less than the noise floor of the channel, the channel is assumed to be linear and noise limited in the remainder of this paper. Furthermore, the noise present in the output signal is due almost entirely due to the thermal noise current present at the receiver side (since the amount of noise power measured did not vary greatly with background illumination). So for the purposes of the analysis to be presented the noise can be considered as Gaussian and white with zero mean and variance  $\sigma_n^2$ .

These results can be combined to justify the channel model in Figure 1(b). This model assumes a linear channel with a wide frequency response to allow for the determination of the bandwidth efficiency of the modulation schemes proposed. The factor  $R$  is the responsivity of the photodiode, and represents an optoelectrical conversion factor (from intensity signal to current signal). The sampled output of the matched filter is used to produce a received symbol which is detected using maximum likelihood (ML) rules (assuming symbols equally likely). The average optical power transmitted in each scheme is set at  $P$  and the bit-error rate (BER) for each scheme is determined.

## 2.2. The Intensity Modulated Channel

The transmission of information using optical intensity channels differs in significant ways from conventional channels. Unlike RF technologies, where the carrier amplitude and phase are varied, wireless IR relies on the intensity modulation of a terahertz range optical signal. The response of the photodiode is the integration of tens of thousands of wavelengths of incident light. Using incoherent, diffuse light sources (for eye safety reasons) only the intensity of the input signal can be determined and therefore transmitted optical signals may assume only positive values, while in conventional channels both positive and negative values are supported. If  $x(t)$  is taken to represent the optical intensity signal, the constraint can be summarized as

$$x(t) \geq 0. \quad (1)$$

This implies that any modulation scheme for an optical intensity channel must have a DC component which transmits no information but consumes energy.

The use of a free-space optical channel imposes a requirement that the average optical power transmitted must be limited for eye-safety reasons. Since the input signal is a varying intensity (power signal), this requirement imposes a restriction on the average *amplitude* of the transmitted signal. If the average optical power permitted is set at  $P$ , this requirement takes the form :

$$\lim_{T \rightarrow \infty} \frac{1}{2T} \int_{-T}^T x(t) dt \leq P. \quad (2)$$

## 3. CONVENTIONAL MODULATION SCHEMES

This section discusses present modulation schemes emphasizing the advantages and shortcomings of each scheme.

### 3.1. Binary Modulation Schemes

Most schemes for data transmission on land-line or wireless optical channels rely on binary levels to transmit data. Schemes such as on-off keying (OOK or 2-PAM) and pulse position modulation (PPM) rely on the use of two levels to transmit data. The specifics of each modulation scheme are discussed in [3, 4] and will not be repeated here. The main advantage of these schemes is that they are highly power efficient since they have high peak to average power ratios. This separates the symbols in the signal space and reduces the probability of error. The price paid by these schemes is their inefficient use of bandwidth. In traditional, fibre optic systems binary schemes are popular due to the abundance of bandwidth available, however, inexpensive free-space links do not share this luxury.

### 3.2. Multilevel Modulation Schemes

In an effort to improve the bandwidth efficiency, multilevel schemes are a prime candidate. These methods improve the bandwidth efficiency by transmitting more information per symbol. Although these schemes allow greater amounts of data to be transmitted through the channel, they are more sensitive to the channel non-linearities and noise than the binary schemes. The two main multi-level modulation schemes are PAM and QAM.

#### L-PAM

In each symbol interval a pulse is sent where the amplitude takes on one of  $L$  possible levels. Figure 3(a) shows the pulse shape for

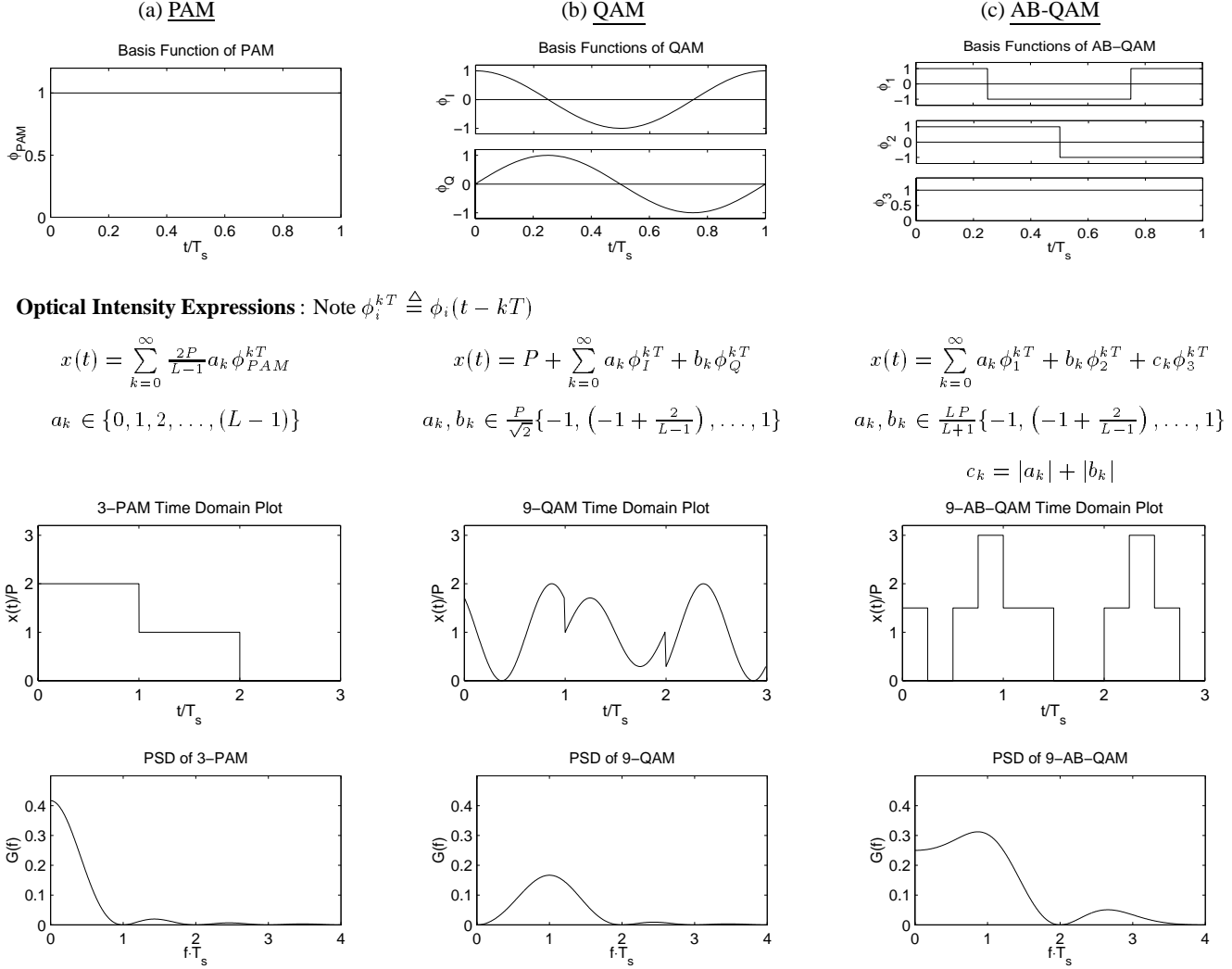

Figure 3: A comparison of three multilevel modulation schemes: (a) PAM, (b) QAM, (c) AB-QAM. Expressions are valid for  $L$  odd.

this modulation scheme as well as the expression for the optical intensity in time. Due to the structure of the pulse,  $x(t)$  remains positive for all time. Assuming that the input symbols are uniformly distributed, the average power is set to  $P$  by evenly spacing the  $L$  levels between 0 and  $2P$ . Using a traditional PAM constellation the BER can be shown to be<sup>1</sup>

$$\text{BER}_{\text{PAM}} \approx \frac{2(L-1)}{L \log_2 L} \cdot Q \left( \frac{RP}{L-1} \sqrt{\frac{\log_2 L}{\sigma_n^2 R_b}} \right).$$

Figure 3(a) also shows the power spectral density of PAM. Using the convention presented in [4], the bandwidth of this scheme

<sup>1</sup> $Q(\cdot)$  is the integral of the standardized Gaussian probability density function  $N(0, 1)$  and can be represented as:

$$Q(x) = \frac{1}{\sqrt{2\pi}} \int_x^\infty \exp(-z^2/2) dz.$$

is taken as the frequency of the first spectral null. A measure of the bandwidth efficiency can be obtained by determining the ratio of the bit-rate ( $R_b$  bits/s) and the bandwidth requirement ( $B$  Hz) and can be shown to take the form :

$$\frac{R_b}{B} = \log_2 L. \quad (3)$$

#### $L^2$ -QAM

For  $L^2$ -QAM, in each signalling interval a composite symbol of in-phase (I) and quadrature (Q) signals is sent. Figure 3(b) presents the two signals as well as an expression for the optical intensity waveform. In order to satisfy Equation 1, a DC bias is added to the signals such that Equation 2 is also satisfied. Regardless of the input data stream, the average optical power on the link is fixed at  $P$ . As a result, the swing available for I and Q signals is limited to  $P/\sqrt{2}$ . The BER for  $L^2$ -QAM can be determined using the channel model in Figure 1(b) by matching the receive filter to the zero-bias sinusoids (the DC level carries no information) and has the following form:

$$\text{BER}_{\text{QAM}} \approx \frac{4L^2 - 8}{2L^2 \log_2 L} \cdot Q \left( \frac{RP}{L-1} \sqrt{\frac{\log_2 L}{2\sigma_n^2 R_b}} \right).$$

The bandwidth efficiency of  $L^2$ -QAM and  $L$ -PAM is the same and is given in Equation 3 (as is also the case in a conventional channel). However, the power efficiency of QAM is 1.5 dB worse than PAM due to the added DC bias of  $x(t)$  which is excessive for small swing values [4].

#### 4. ADAPTIVELY BIASED QAM (AB-QAM)

The essential features of AB-QAM are illustrated in Figure 3(c), where the basis functions, time domain response and power spectral density are presented.

AB-QAM provides an asymptotic SNR gain of 3 dB over PAM by implementing two main concepts : (i) the amount of DC bias added to each symbol is minimized such that the output signal remains non-negative (constraint imposed by Equation 1) and (ii) the information contained in this symbol average is used to provide a degree of diversity in the receiver, which further improves the power efficiency.

As mentioned above, QAM adds a fixed DC bias to each symbol to ensure that the output remains non-negative. Although a simple solution, this scheme proves to be inefficient for small valued signals, since power is wasted in the excessive DC bias. AB-QAM adds an adaptive DC bias to each symbol, such that the minimum value of each symbol is fixed at zero. As a result, the average of each symbol will vary according to the probabilistic distribution of the data symbols transmitted. This varying symbol average is exploited to increase the allowed swing of the symbol as is done in PAM.

Unlike traditional intensity modulation schemes, where the DC bias of each symbol is ignored, in AB-QAM the correlation of the symbol bias to the data being sent is used to improved the minimum distance between symbols. Matched filtering to  $\phi_1$  and  $\phi_2$  provides sufficient statistics to extract the in-phase and quadrature symbols, however, the use of the correlated information in the  $\phi_3$  dimension provides a degree of signal-space diversity. The built-in redundancy of the PAM signal resulting from adaptive biasing can be exploited to improve the power efficiency further. From geometrical reasoning, it can be shown that by exploiting this diversity, the  $d_{\min}$  of the constellation is improved by a factor of  $\sqrt{2}$  or equivalently a 1.5 dB improvement in the SNR.

The total SNR improvement of AB-QAM over PAM can be determined by combining the impact of the effects above and is given by the expression below. (valid for  $L^2$  odd, where  $L^2$  is the number of elements in the AB-QAM constellation)

$$\frac{\text{SNR}_{\text{AB-QAM}}}{\text{SNR}_{\text{PAM}}} = \sqrt{2} \cdot \frac{\sqrt{2}L}{L+1} \Rightarrow 3\text{dB} - 10\log_{10} \left( \frac{L+1}{L} \right)$$

This improvement can be translated into a BER expression for  $L^2$ -AB-QAM, and is given in the following expression:

$$\text{BER}_{\text{AB-QAM}} \approx \frac{6L^2 - 8L + 14}{2L^2 \log_2 L} \cdot Q \left( \frac{2LRP}{L^2 - 1} \sqrt{\frac{\log_2 L}{\sigma_n^2 R_b}} \right).$$

As shown in Figure 3(c), the bandwidth efficiency of this scheme is the same as QAM and PAM. However, it must be noted that AB-QAM has more side lobe power which is not accounted for in the

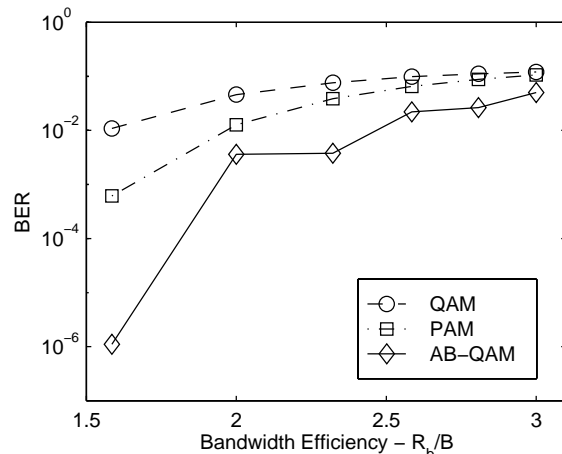

Figure 4: Simulation results of AB-QAM versus PAM and QAM baseline data. Plots of bit-error rate against bandwidth efficiency.

bandwidth measure of [4]. Pulse shaping techniques are currently being investigated to reduce this out-of-band power.

Figure 4 contains a comparison of the bit-error rate versus bandwidth efficiency for theoretical PAM scheme and simulation results of QAM and AB-QAM. Simulation results for AB-QAM and QAM were obtained in MATLAB using the channel model in Figure 1(b). The variation in the improvement of AB-QAM for even and odd constellation sizes is due to fact that even constellations do not have a zero symbol which introduces an unfavourable boundary condition in the three dimensional constellation.

#### 5. CONCLUSIONS

This paper has discussed the need of multilevel modulation schemes for free-space optical communications. The advantages of binary modulation schemes are outweighed by their poor bandwidth efficiencies. The use of PAM and QAM schemes is investigated and expressions for BER and bandwidth efficiency are developed. A new modulation scheme, Adaptively Biased QAM, was proposed with an asymptotic 3 dB improvement in SNR over PAM for the same bandwidth efficiency.

Currently, pulse shaping techniques are being investigated to reduce the amount of power in the side-lobes of AB-QAM.

#### 6. ACKNOWLEDGMENT

The authors would like to thank Frank Kschischang for his helpful comments and discussions in preparing this paper as well as for proof-reading the final paper.

#### 7. REFERENCES

- [1] IrDA - Infrared Data Association - [www.irda.org](http://www.irda.org)
- [2] H. Kressel, "Semiconductor Devices for Optical Communication," Springer-Verlag, 1980.
- [3] H. Park, J. R. Barry, "Modulation Analysis for Wireless Infrared Communications," Proc. IEEE Int. Conf. Commun., pp. 1182-1186, 1995.
- [4] J. R. Barry, "Wireless Infrared Communications," Kluwer Academic Publishers, Boston, 1994.