

# Northumbria Research Link

Citation: Bobor-Oyibo, Freeborn, Foti, Steve and Smith, Dave (2008) A multiple switched beam smart antenna with beam shaping for dynamic optimisation of capacity and coverage in mobile telecommunication networks. In: Proceedings of the 8th International Symposium on Antennas, Propagation and EM Theory, 2008 (ISAPE 2008). IEEE, Piscataway, NJ, pp. 356-359. ISBN 978-1424421923

Published by: IEEE

URL: <http://dx.doi.org/10.1109/ISAPE.2008.4735219>  
<<http://dx.doi.org/10.1109/ISAPE.2008.4735219>>

This version was downloaded from Northumbria Research Link:  
<http://nrl.northumbria.ac.uk/id/eprint/647/>

Northumbria University has developed Northumbria Research Link (NRL) to enable users to access the University's research output. Copyright © and moral rights for items on NRL are retained by the individual author(s) and/or other copyright owners. Single copies of full items can be reproduced, displayed or performed, and given to third parties in any format or medium for personal research or study, educational, or not-for-profit purposes without prior permission or charge, provided the authors, title and full bibliographic details are given, as well as a hyperlink and/or URL to the original metadata page. The content must not be changed in any way. Full items must not be sold commercially in any format or medium without formal permission of the copyright holder. The full policy is available online: <http://nrl.northumbria.ac.uk/policies.html>

This document may differ from the final, published version of the research and has been made available online in accordance with publisher policies. To read and/or cite from the published version of the research, please visit the publisher's website (a subscription may be required.)

# A Multiple Switched Beam Smart Antenna with Beam Shaping for Dynamic Optimisation of Capacity & Coverage in Mobile Telecommunication Networks

Freeborn Bobor-Oyibo<sup>#1</sup>, S. J. Foti<sup>\*2</sup>, David Smith<sup>#3</sup>

<sup>#</sup>*School of CEIS, Northumbria University  
Newcastle upon Tyne, NE1 8ST, United Kingdom*

<sup>1</sup>freeborn.bobor-oyibo@northumbria.ac.uk

<sup>3</sup>david.smith@northumbria.ac.uk

*Lonning House, Elsdon, Northumberland, NE191BS, United Kingdom*

<sup>2</sup>stevefoti@boundarystudios.com

**Abstract**— A four column Smart antenna array fed by a 4x4 Butler matrix augmented by a variable beam shaping network has been designed and simulated. It is demonstrated that using only three phase shifters within the beam shaping network provides dynamic beam flexibility including: four narrow switched beams, a right shaped beam, a left shaped beam and a broad broadcast channel beam. The shaped beams concentrate coverage at high capacity in either the right or left half of a sector while maintaining coverage at lower capacity over the remainder of the sector. The resultant antenna system represents an improvement in performance over a single multiple switched beam smart antenna without the cost and complexity of a fully adaptive smart antenna. Simulated radiation patterns over the full 3G frequency band show that useful dynamic coverage & capacity enhancement can be implemented with the proposed antenna system.

**Index Terms**—Antenna arrays, antenna radiation patterns, array signal processing, microwave antennas, mobile communications, shaped beam antennas.

## I. INTRODUCTION

A key problem of capacity in mobile telecommunication networks lies in traffic load imbalance across the network cell sites. Various methods have been used to correct the problem of the imbalance from first generation of wireless communications to third generation [1], [2], however, all techniques have limitations. The application of smart antennas in mobile telecommunication networks has also widely been investigated [3-5]. The majority of the great effort in current studies of smart antennas has been directed towards the quantification of the capacity increase smart antennas can offer and propagation effects [6],[7]. The use of smart antennas to dynamically optimize the network for better coverage and capacity has received significantly less attention up to now. Using the approach of a multiple switched beam

antenna system and a beam shaping network, an intelligent sector optimization of varying azimuth beam shape can be established. The proposed technique can be used to dynamically optimize coverage and capacity especially for hotspots in mobile network cell sectors. Furthermore, base stations are typically equipped with one transceiver per sector (per polarization) with a conventional sector antenna and it is cost effective not to increase the number of existing transceivers. In this paper we propose a smart antenna that will dynamically optimize a cell sector to relieve congestion at a single hot-spot cell sector.

## II. SMART ANTENNAS

The Smart antenna is one of the promising technologies in wireless communications for systems to provide interference reduction and enhance user capacity [8]. This is achieved by focusing the radiation only in the desired direction and adjusting itself to changing traffic conditions or signal environments. The signals from these elements are combined to form a switchable beam pattern that can be directed to the desired user [9]. The most important of all the benefits of a smart antenna is the ability to serve more users per base station thereby increasing revenues of network providers and also giving network subscribers less probability of blocked or dropped calls [10]. There are basically two types of smart antennas systems: fully adaptive and multiple fixed beams. Many studies have shown that multiple switched fixed beams offer increased capacity and are less complex compared to the fully adaptive smart antenna [11]. The aim of the multiple fixed-beam system is to increase the gain in the direction of the desired user and to reduce gain in the direction of other users (interferers). The multiple fixed- beam approach is simpler compared to the fully adaptive approach [12]. However, the multiple fixed beam design is limited when only one transceiver is available because only one narrow beam at

a time can be used. The block diagram of the proposed smart antenna system is shown in figure 1. The fundamental components of the system are: the antenna array, multiple beam forming network (4x4 Butler Matrix) and the beam shaping network. Each of the antenna columns has a gain of 17.5dBi. The horizontal beam shape produced by the antenna array is dependent upon the complex weights (magnitude and phase) applied to each array column. The complex weights are provided by the array feed network. The total feed network is realised by cascading a 4x4 Butler matrix beam forming network and a beam shaping network. The former produces multiple narrow beams each corresponding to a signal at one of the four beam ports and latter provides a combination of excitation (i.e. "beam blending") to each of the beam ports. The 4x4 Butler Matrix produces equal amplitudes and linear phase progressions to the array elements and the beam shaping network provides simultaneous excitation of the beam ports with relative amplitudes and phase. The relative amplitudes are dynamically changed by adjusting the three phase shifters within the beam shaping network, (BSN). This results in the required complex weights at the array elements.

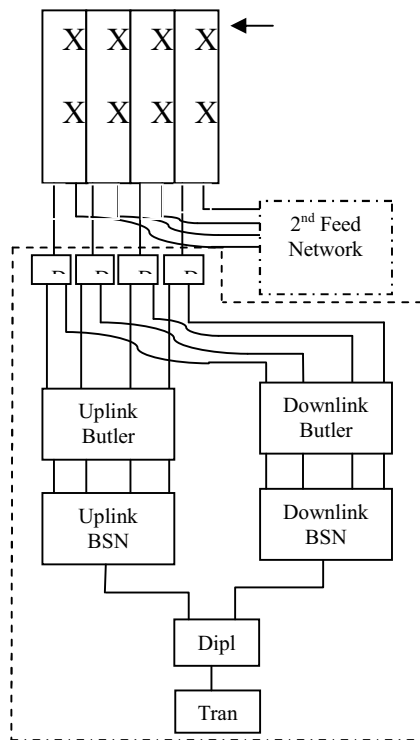

Figure 1 Smart Antenna system with beam shaping

### III. BEAM FORMING AND BEAM SHAPING NETWORKS

#### A. Beam Forming Network

The Butler matrix has been chosen for this design because it is simple to realize compared to other beam-forming networks.

It is a beam forming network that uses a combination of 90° hybrids and fixed transmission line phase shifters to form N simultaneous independent beams from an N element antenna array. It performs a spatial discrete Fourier transform and provides overlapping orthogonal beams. When used with a linear array the Butler matrix produces beams that overlap at 3.9 dB below the beam maximum. A Butler matrix-fed array can provide beams that can be used by a dedicated transmitter and/or receiver, or a single transmitter and/or receiver can be used and the appropriate beam can be selected using an RF switch. Any signal input into one of the butler matrix input ports will be divided equally among the output ports with a progressive phase delay. The passive Butler matrix will be dynamically controlled by the beam shaping network. Depending upon the communications traffic demand, a control algorithm can adjust the relative power divider/combiner ratio to blend all the beams, or do beam switching or beam broadening for optimum service.

#### B. Beam Shaping Network

The beam shaping network is essentially a variable 4-way power divider/combiner that utilizes a 2-way variable power divider/combiner which drives two 2-way variable power dividers/combiners as shown in Figure 2.1. Each 2-way variable power divider/combiner is realised as shown in the network of figure 2.2.

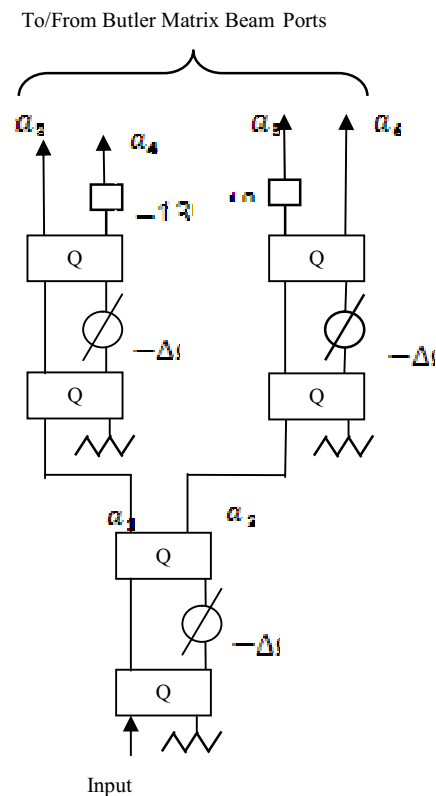

Figure 2.1 Beam Shaping Network

In order to adapt to an unequal user distribution between beams it is of a great advantage to share the power that is available to serve a sector dynamically between the beams of the sector providing more power to areas that have more users. The advantage of this dynamic sharing is to reduce dropped calls in a sector. The angular beam width of the sector smart antenna can be dynamically shaped to the right or left hand of the sector to accommodate the traffic of the sector. The proposed smart antenna has three shaped beams. They are the right-hand shaped beam, left-hand shaped beam and a broad shaped beam for the broadcast channel to avoid the use of separate integrated sector antenna for the broadcast channel. These are in addition to the four narrow overlapping beams. 3G systems need constant monitoring and continuous optimization for coverage and capacity because of the subscriber locations in the sector and traffic behaviour. The behaviour of the traffic demand affects the network quality of the mobile network provider [13]. To avoid coverage holes cell overlaps have been used as a remedy, but waste power when the traffic demand moves to another sector. In order to adapt to an unequal user distribution between beams it is of a great advantage to share the power that is available to serve a sector dynamically between the beams of the sector providing more power to areas that have more users. The advantage of this dynamic sharing is to reduce dropped calls in a sector. The angular beam width of the sector smart antenna can be dynamically shaped to the right or left hand of the sector to accommodate the traffic of the sector. The proposed smart antenna has three shaped beams, right-hand shaped beam, left-hand shaped beam and a broad shaped beam for the broadcast channel to avoid the use of separate integrated sector antenna for the broadcast channel. These are in addition to the four narrow overlapping beams.

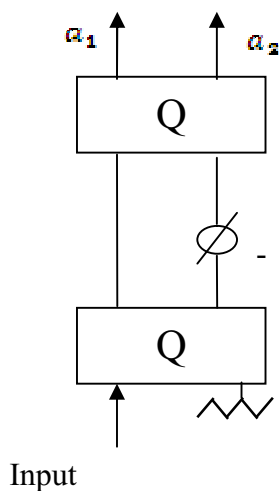

Figure 2.2. 2-way variable power divider/combiner controlled by one phase shifter

## I IV. SIMULATION RESULTS

### C. Multiple Narrow Beams

The performance of the proposed smart antenna over the uplink and downlink bands for a specific UK 3G network operator (Orange, UK), ( downlink  $f_L, f_C, f_H = 2.1597\text{GHz}, 2.1647\text{GHz}, \text{ and } 2.1697\text{GHz}$  and uplink  $f_L, f_C, f_H = 1.9697\text{GHz}, 1.9747\text{GHz} \text{ and } 1.9797\text{GHz}$  ) has been simulated for multiple narrow beams as shown in Figure 3 and Figure 4. It was found that the beams are virtually invariant over each of the bands based upon the ideal network model and the narrow uplink and downlink bands.

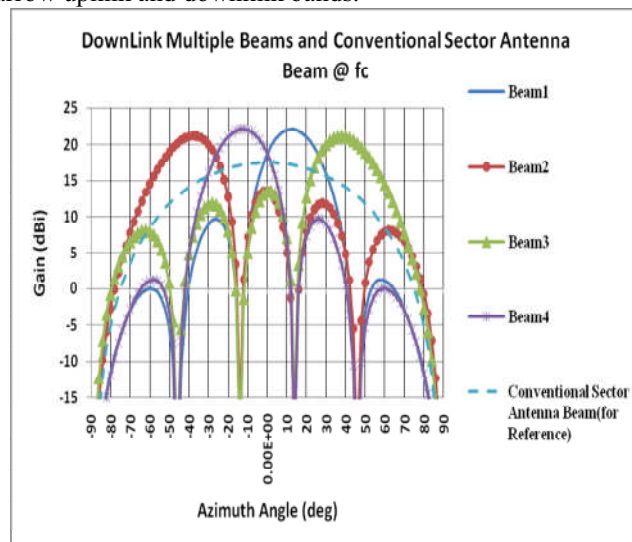

Figure 3 Downlink Multiple Narrow beams @  $f_c = 2.165\text{GHz}$

### D. Steered Beams

In addition to generating multiple narrow beams this arrangement is also able to generate shaped beams through a simple variation of the complex weightings. Figure 5 and figure 6 present the right, left and broad shaped beams for the uplink and downlink for this antenna. Again it has been found these beam shapes are virtually frequency invariant over their respective bands based over the uplink and downlink bands.

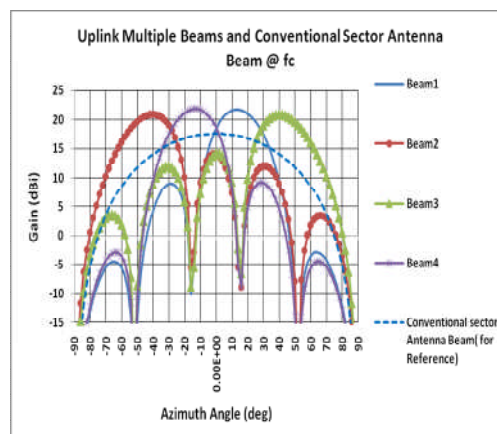

Figure 4 Uplink Multiple Narrow beams @  $f_c = 1.975\text{GHz}$

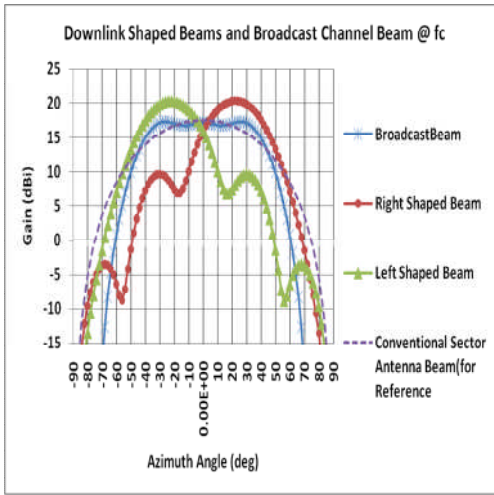

Figure 5. Downlink Shaped beams @  $f_c = 2.165\text{GHz}$

## V. CONCLUSIONS

This research has explored the importance of using smart antenna systems for traffic load balancing especially in hotspots of wireless networks. We have successfully designed, simulated and analysed a multiple switched beam smart antenna with beam shaping augmentation for dynamic optimization of capacity and coverage for the up and downlinks of 3G mobile telecommunication networks. Future work to aid network planners could employ this Smart Antenna System computer model coupled with a suitable propagation model and terrain map to predict “beam footprint” contour plots for specific geographical regions.

## REFERENCES

- [1] T. Yum and W. Wong, Hot-spot traffic relief in cellular systems, *IEEE Journal on Selected Areas in Communications*, vol. 11, no. 6, pp. 934-940, August 1993.
- [2] Y. Argyropoulos, S. Jordan, and S. Kumar, Dynamic channel allocation in interference-limited cellular systems with uneven traffic distribution, *IEEE Transactions on Vehicular Technology*, vol. 48, no. 1, pp 224-232, January 1999
- [3] C. Lee, H. Kang, and T. Park, “Dynamic sectorization of microcells for balanced traffic in cdma: genetic algorithms approach,” *IEEE Trans. Veh. Technol.*
- [4] Lehne, P. H, and Pettersen, M. ‘An overview of Smart Antenna Technology for mobile communication systems’ *IEEE communications surveys*, vol.2, pp.2-13, 1999.
- [5] L. Godara, “Applications of antenna arrays to mobile communications, Part I: Performance improvement, feasibility, and system considerations,” *Proc. IEEE*, vol. 85, pp. 1031–1060, Jul. 1997.
- [6] A. Osseiran and A. Logothetis, ‘Smart Antenna in a WCDMA Radio Network System: Modeling and Evaluations, *IEEE transaction on Antennas and propagation* Vol.54, No 11 November, 2006 pp. 3302-3316

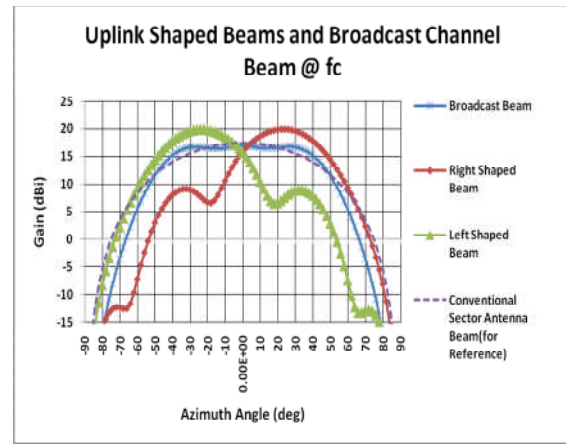

Figure 6. Uplink Shaped beams @  $f_c = 1.975\text{GHz}$

- [7] K. I. Pedersen, P. E. Mogensen, and J. R. Moreno, “Application and performance of downlink beamforming techniques in UMTS,” *IEEE Commun. Mag.*, pp. 134–143, Oct. 2003.
- [8] R.H. Roy, ‘An overview of smart Antenna technology: the Next Wave in Wireless Communication,’ 1998 IEEE Aerospace Conference, Vol.3 pp. 339-345, May 1998
- [9] W. L. Stutzman and G. A. Thiele (1981), ‘Antenna theory and Design’, John Wiley & Sons, New York.
- [10] J. Litva and T. K.-Y. Lo (1996), *Digital Beamforming in Wireless Communications*, Artech House, Boston.
- [11] C A. Osseiran et al., ‘Downlink capacity comparison between different smart antenna concepts in a mixed service WCDMA system,’ in *proc. IEEE Veh. Technol. Conf. Fall*, Atlantic City NJ, 2001, vol. 3, pp. 1528-1532.
- [12] J. C. Liberti, Jr., and T.S. Rappaport, (1999), *Smart Antennas for wireless communications: IS-95 and Third Generation CDMA Applications*, Prentice Hall PTR, Upper Saddle River, NJ.
- [13] J. Laiho, A. Wacker and T. Novosad ‘Radio Network Planning and Optimisation for UMTS second Edition, John Wiley & Sons Ltd 2006.