



Enhancement Power Quality with Sugeno-type Fuzzy Logic and Mamdani-type Fuzzy Logic Base on DVR

Mohamed Mohamed Khaleel¹

M.Sc. Eng. St. Research Scholar (Electrical Engineering for Renewable Energy), Dept. MEC E, Sebelas Maret University, Surakarta, Indonesia¹

ABSTRACT: Power quality is closely related issues of most directly affect nowadays. It can be clear that electrical power quality is the degree of any deviation from the nominal rate of the voltage magnitude and frequency. Voltage sag is one of the most significant power quality problems challenging at present time. This paper discussed modeling of a DVR with PI controller, Sugeno-type Fuzzy Logic and Mamdani-type Fuzzy Logic using Matlab/Simulink in order to mitigate voltage sag. Then analyze the performance of DVR in order to solve the problem of voltage sag by installed DVR between the supply voltage and a sensitive load, DVR has injected the current to the distribution network during voltage sag. Consequence showed that PI control was able successfully to overcome the voltage by 93.00, 86.50, and 80.25 percents in single-phase, two-phase and three-phase respectively. Sugeno-type Fuzzy Logic was able successfully to overcome the voltage 98.05, 96.40 and 94.20 percents in single-phase, two-phase and three-phase respectively. Mamdani-type Fuzzy Logic was able successfully to overcome the voltage 97.6, 93.3 and 91.60 percents in single-phase, two-phase and three-phase respectively. Sugeno-type Fuzzy Logic showed to be better performance for solving voltage sag problem of power quality than Mamdani-type Fuzzy Logic. Mamdani-type Fuzzy Logic showed to be better for solving voltage sag problem of power quality than PI control. The analyze of the performance proved that DVR is the most efficient and effective modern customer power device used in distribution network which able to keep the customer on-line with high quality. It can be seen by the preceding information. DVR was able to mitigate voltage sag on distribution networks due voltage sag.

KEYWORDS: Power Quality, Voltage Sag, Dynamic Voltage Restorer (DVR), Sugeno-type Fuzzy Logic, Mamdani-type Fuzzy logic, PI Control, MATLAB.

I. INTRODUCTION

Dynamic Voltage Restorer are now becoming remarkably well-established in industry to mitigate the impact of voltage sag in distribution system[1]. According to the IEEE standard, voltage sag is increase of 0.1 to 0.9 per unit in RMS voltage level at the system frequency and with duration of half cycle to One minute. Voltage swell is not as important as voltage sag. This is because voltage swell is less than voltage sag in distribution system[2]. Voltage sag might caused by change in loading conditions or remote faults[3]. DVR is discussed in this paper is one of the customer power devices that can deal perfectly with voltage sag in distribution system by injection current into system. The control method of DVR is also important issue as it has to immediately the voltage at point of common coupling (PCC) instantaneously [3]. Therefore. The main objective of this paper analyse the result of PI controller, sugno-type fuzzy logic, mamdani-type fuzzy logic in order to mitigate thr voltage sag. The modeling of DVR has been carried out using MATLAB with its Fuzzy Logic Toolbox.

The rest of paper is organized as follows: Definition of power quality is presented in section II. Dynamic voltage Restorer is presented in section III. Result and discussion is presented in section IV. And finally, conclusion is presented in section V.

International Journal of Advanced Research in Electrical, Electronics and Instrumentation Engineering

(An ISO 3297: 2007 Certified Organization)

Vol. 3, Issue 4, April 2014

II. DEFINITION OF POWER QUALITY

Power quality is a term that means different things to different people. IEEE Standard IEEE 1100 defines power quality as “the concept of powering and grounding sensitive electronic equipment in a manner suitable for the equipment” In fact, all electrical devices are susceptible to breakdown or malfunction when exposed to one or more power problems. The electrical device could be a computer, an electrical motor, or household appliance. All of these devices can have an adverse effect on the power quality problem. That depends on extensive number of electromagnetic phenomena in power system with its broad the range of time [4].

III. DYNAMIC VOLTAGE RESTORER (DVR)

A DVR is also referred as the Series Voltage Booster, is a device that utilizes solid state power electronic components [5]. DVR is a device that injects dynamically controlled voltage in series to the bus voltage by booster transformer [6]. DVR injects the missing current in series with line that load voltage maintained at sinusoidal normal situation in power system. The general configuration of the DVR consists of injection voltage transformer, DC energy storage, Voltage source inverter, and Control unit as depicted in Figure 1.

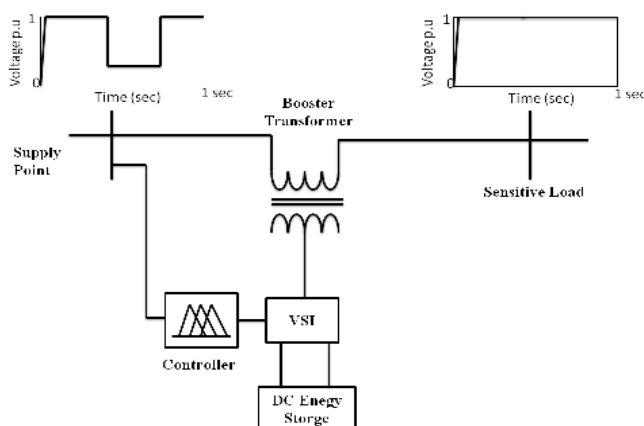

Fig. 1 Schematic diagram of DVR system

Figure 1. shown the basic function of booster transformer is injected current in distribution network. Voltage source inverter can generate a sinusoidal voltage at any needed Magnitude, Frequency, and phase angle. The DC energy storage provides the real power requirement of DVR during occurrence of voltage sag. And finally, the goal of Sugeno-type Fuzzy Logic and Mamdani-type Fuzzy Logic which controls the inverter of DVR, has been discussed in place of conventional PI controller in order to maintain voltage magnitude at the load where a sensitive load is connected in power system.

IV. RESULT AND DISCUSSION

Enhancement power quality with sugeno-type fuzzy logic, mamdani-type fuzzy logic, and PI controller based on DVR was tested using MATLAB Simulink. The simulink of PI controller is shown in figure 2. System parameters are listed in table 1. Voltage sag is created in simulink via single-phase, two-phase, three-phase fault. MATLAB Simulink of Sugeno-type fuzzy logic and Mamdani-type fuzzy logic of DVR is shown in figure 3 which is display at the of this paper.

CASE 1: PI CONTROLLER

PI Controller (proportional-integral controller) is a close loop controller which drives the plant to be controlled with a weighted sum of error and integral that value. PI Controller has the benefit of Steady-state error to be zero for a step input.

$$\text{Output of comparator} = V_{\text{ref}} - V_{\text{in}} \quad (1)$$

Where,

International Journal of Advanced Research in Electrical, Electronics and Instrumentation Engineering

(An ISO 3297: 2007 Certified Organization)

Vol. 3, Issue 4, April 2014

V ref equal 1 per unit voltage reference
V in Volatage in 1 per unit at the load terminals

PI controller input is an actuating signal which is the difference between the V ref and Vin Output of the controller block the angles. The angle provides to PWM signal generator to obtain desired firing sequence. Fig. 2 is shown model of PI controller in MATLAB.

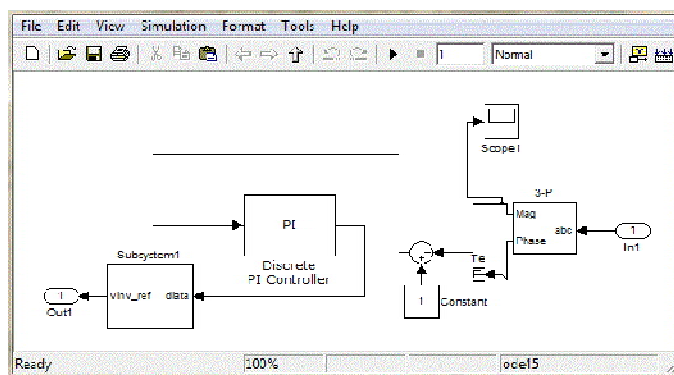

Fig 2. Model of PI controller in MATLAB

CASE 2: SUGENO-TYPE FUZZY LOGIC & MAMDANI-TYPE FUZZY LOGIC

Sugeno-type fuzzy logic controller have been of great attention in the industrial applications. The main idea is based on the use of sector nonlinearity concept, which decomposes a complex nonlinear system into a set of linear subsystems using fuzzy IF-THEN rules. A fuzzy logic controller or model uses fuzzy logic rules, which are linguistic if-then statements involving fuzzy sets, fuzzy logic, and fuzzy inference. Fuzzy rules play a key role in representing expert control/modeling knowledge and experience and linking the input variables of fuzzy controller/ models output variable. In this paper, two major type of fuzzy logic rules have been carried out on DVR in order to mitigate voltage sag, namely, Sugeno-type Fuzzy Logic and Mamdani-type Fuzzy Logic. The most essential difference between Mamdani-type Fuzzy Logic and Sugeno-type Fuzzy Logic is the way of the crisp output generated from the fuzzy inputs. While Mamdani-type Fuzzy Logic required the technique of defuzzification of fuzzy output on DVR Simulation and combined using aggregation operator from the consequent of each rule of the input that have been used in Simulation. A single if-then rule is written as;

IF —"X" is A, THEN —"Y" is B

Mamdani-type fuzzy logic and Sugeno-type fuzzy logic approaches were considered in order to mitigate voltage sag using DVR. The Membership Function for Mamdani-type Fuzzy Logic and Sugeno-type fuzzy logic is shown below:

International Journal of Advanced Research in Electrical, Electronics and Instrumentation Engineering

(An ISO 3297: 2007 Certified Organization)

Vol. 3, Issue 4, April 2014

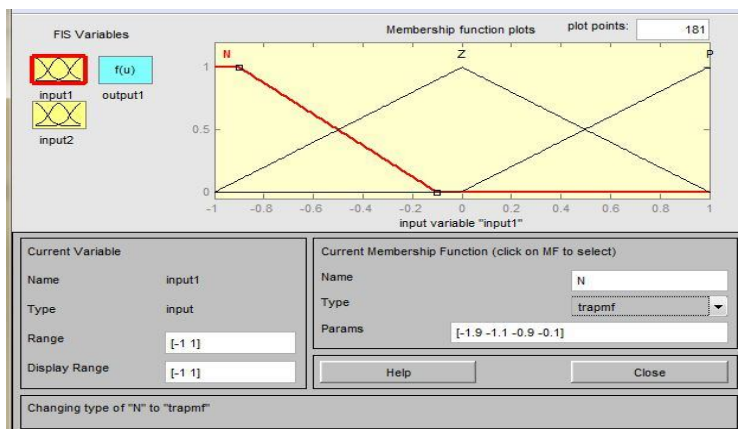

Fig. 3 Membership Function for Mamdan-type Fuzzy Logic Input Variable

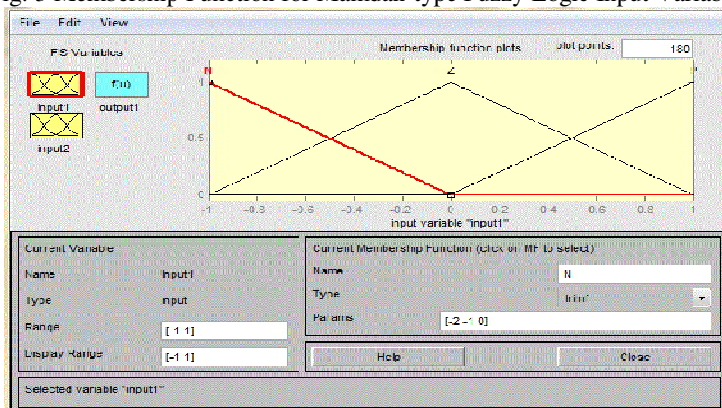

Fig. 4 Membership Function for Sugeno-type Fuzzy Logic Input Variable

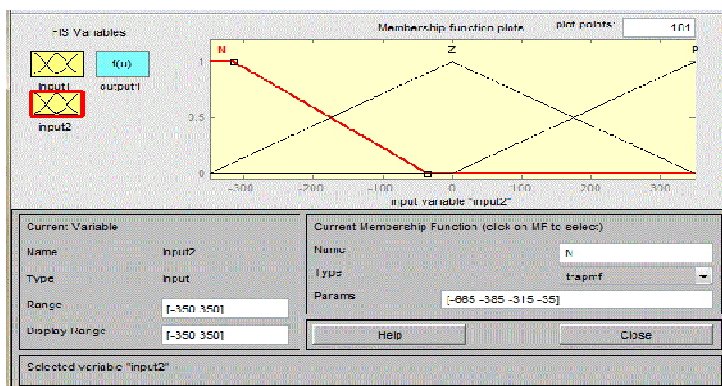

Fig. 5 Membership Function for Mamdan-type Fuzzy Logic Input Variable

International Journal of Advanced Research in Electrical, Electronics and Instrumentation Engineering

(An ISO 3297: 2007 Certified Organization)

Vol. 3, Issue 4, April 2014

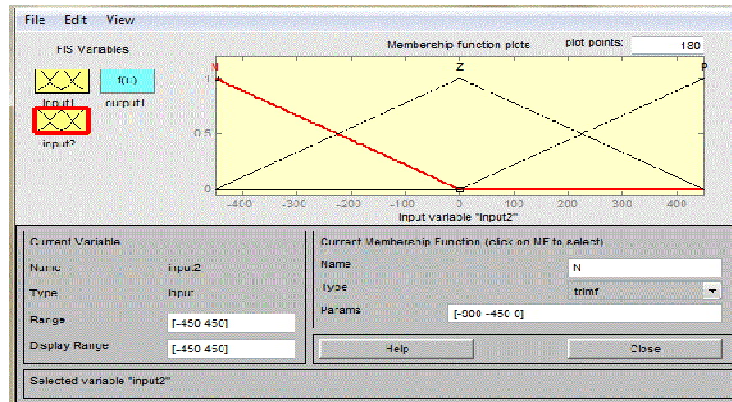

Fig. 6 Membership Function for Sugeno-type Fuzzy Logic Input Variable

Sugeno-type fuzzy logic has no output membership functions in fuzzy toolbox. On other hand, Mamdani-type fuzzy logic is less adaptable in system design in comparison to sugeno-type fuzzy logic as latter can be integrated with ANFIS tool to optimize the outputs. The output variable of Mamdani-type fuzzy logic also has five membership functions namely; Negative Big, Negative Small, Zero, Positive Big, and Positive Small shown in figure 7 below:

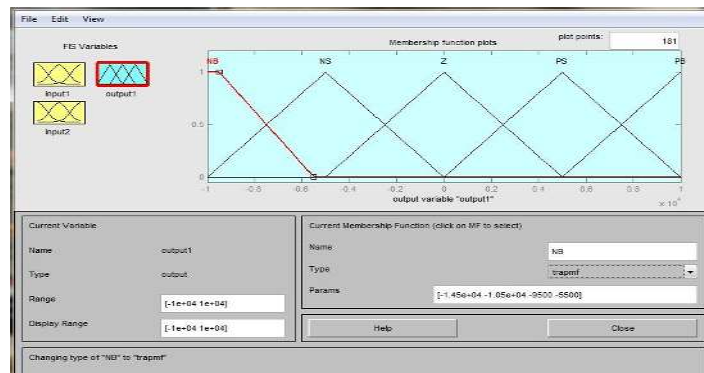

Fig. 7 Membership Function for Mamdani-type Fuzzy Logic Output Variable

These rules in figure 8 was applied to the inputs and the output of the Mamdani-type fuzzy logic system based on DVR controller using Fuzzy Logic Toolbox.

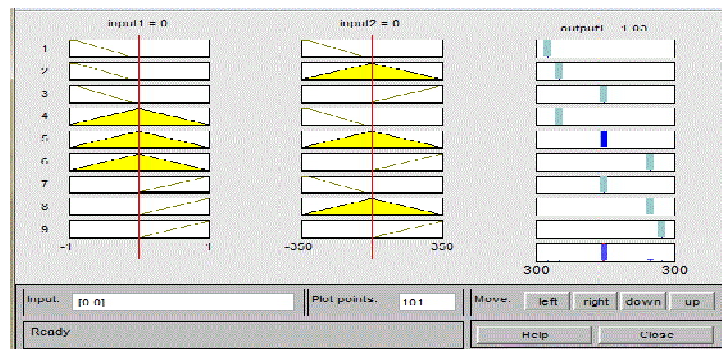

Fig. 8 Mamdani-type based rule viewer for controller

International Journal of Advanced Research in Electrical, Electronics and Instrumentation Engineering

(An ISO 3297: 2007 Certified Organization)

Vol. 3, Issue 4, April 2014

These rules in figure 9 was applied to the inputs and the output of the Sugeno-type fuzzy logic system based on DVR controller using Fuzzy Logic Toolbox.

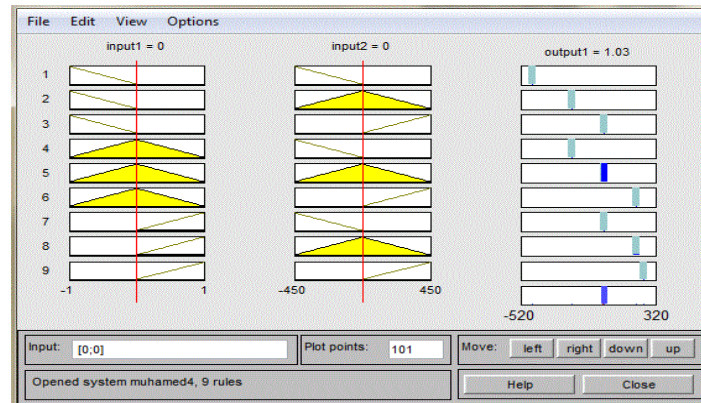

Fig. 9 Sugeno-type based rule viewer for controller

There were four simulations done in this paper, i.e., Simulation of distribution network without installation of DVR, simulation of DVR based on the PI controller, simulation of DVR based on Mamdani-type fuzzy logic, and simulation of DVR based on Sugeno-type fuzzy logic in distribution network. There were tested using MATLAB SIMULINK, result were analyzed. The voltage sag occurred at the time duration of 0.4 to 0.7 secs

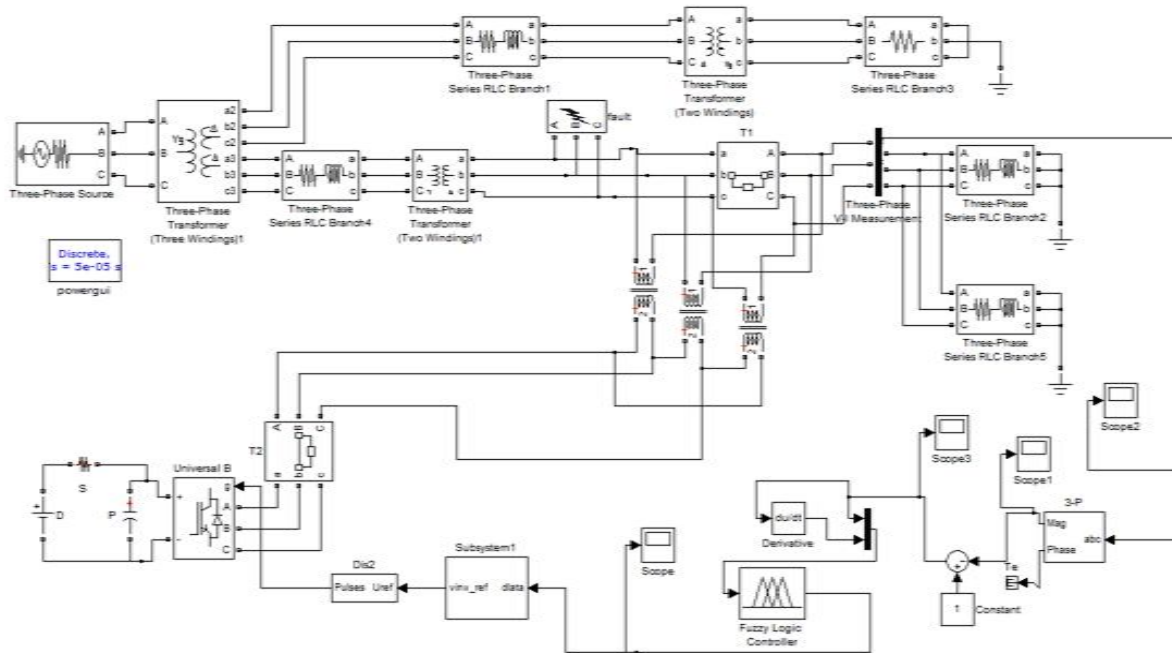

Fig. 9 Matlab/Simulink Power Circuit Model of DVR

International Journal of Advanced Research in Electrical, Electronics and Instrumentation Engineering

(An ISO 3297: 2007 Certified Organization)

Vol. 3, Issue 4, April 2014

Table 1. System Parameters

System Quantities	Ratings
Voltage source	32 kV
DC Voltage source	4kV
Line Frequency	50 Hz
Series Transformer Turns Ratio	1:1
IGBT generator	3-arm bridge (6 pulses), 1000 Hz
Line Impedence	Ls = 0.004 H, Rs = 0.002 Ω
Foult Resistances	0.33 Ω
Load Resistance	60 Ω
Load Inductance	0.116 H

a. Control Surfaces Using Mamdani-type and Sugenu-type Fuzzy Logic

The plot was of simulation of Mamdani-type fuzzy logic and Sugenu-type fuzzy logic. The surface viewer of Mamdani-type fuzzy logic and Sugenu-type fuzzy logic is presented in figure 10 and 11.

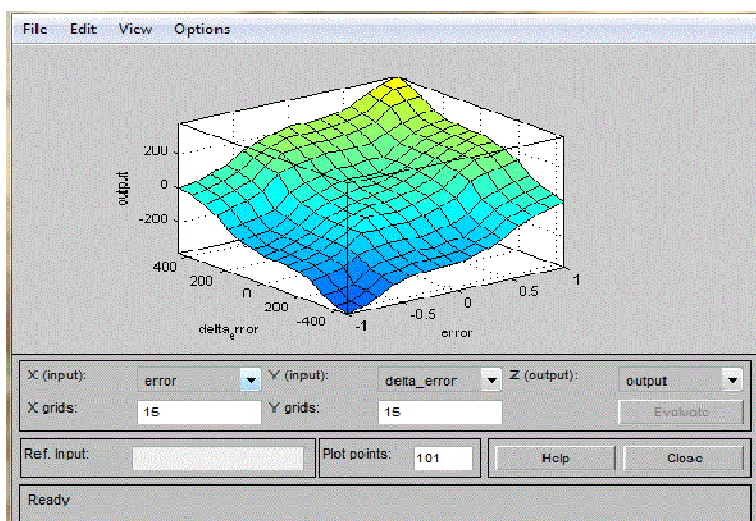

Fig. 10 Surface View Using Mamdani-type Fuzzy Logic Algorithm

International Journal of Advanced Research in Electrical, Electronics and Instrumentation Engineering

(An ISO 3297: 2007 Certified Organization)

Vol. 3, Issue 4, April 2014

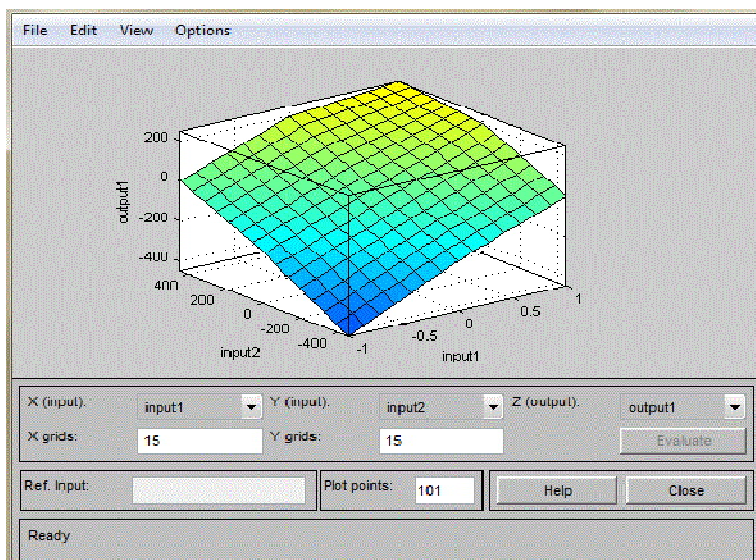

Fig. 11 Surface View Using Sugeno-type Fuzzy Logic Algorithm

b. Simulation of Dynamic Voltage Restorer System

The first simulation was done without dynamic voltage restorer and a three phase fault is applied to the system for a time duration of 400 ms. The second simulation is carried out at the same scenario as above but using DVR with PI controller. The simulation is carried out at the same scenario as above but has different scenario usage of DVR with sugeno-type and mamdani-type fuzzy logic. Below is the result of the reduction of sag on a network system with the application of the three methods, the PI controller, sugeno-type fuzzy logic and mamdani-type fuzzy logic on the same distribution network. Sugeno-type fuzzy logic and Mamdani-type fuzzy logic have the function in order to mitigate the value of voltage sag during single, two, and three phase distribution with a level of handling most perfect way. single-phase comparison of sugeno-type fuzzy logic, mamdani-type fuzzy logic, PI controller, and without DVR is shown in figure 12.

International Journal of Advanced Research in Electrical, Electronics and Instrumentation Engineering

(An ISO 3297: 2007 Certified Organization)

Vol. 3, Issue 4, April 2014

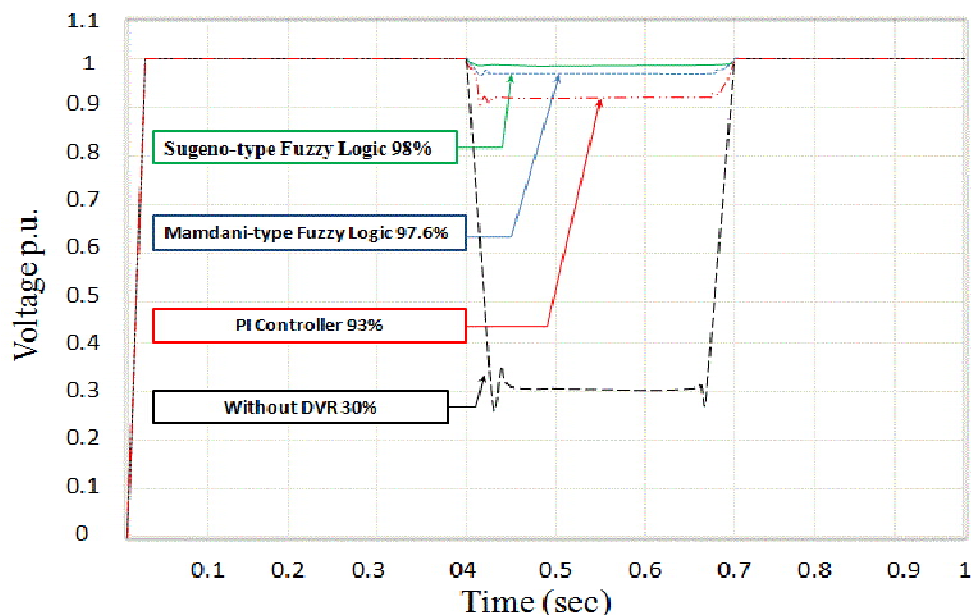

Fig. 12 (a) Single-Phase Comparison of Sugeno-Type Fuzzy Logic, Mamdani-Type Fuzzy Logic, PI Controller, and Without DVR

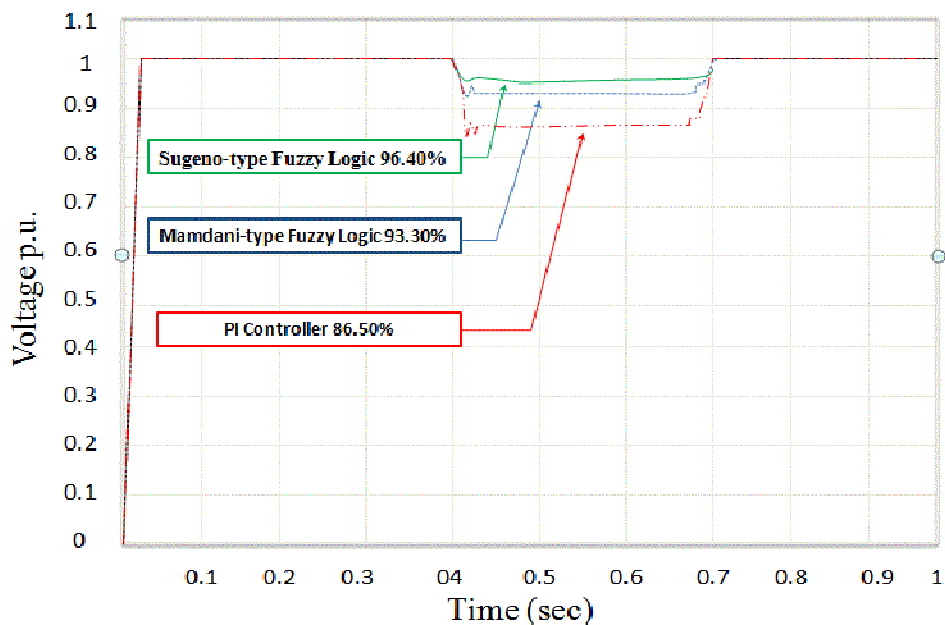

Fig. 13 (b) Two-Phase Comparison of Sugeno-Type Fuzzy Logic, Mamdani-Type Fuzzy Logic, and PI Controller

International Journal of Advanced Research in Electrical, Electronics and Instrumentation Engineering

(An ISO 3297: 2007 Certified Organization)

Vol. 3, Issue 4, April 2014

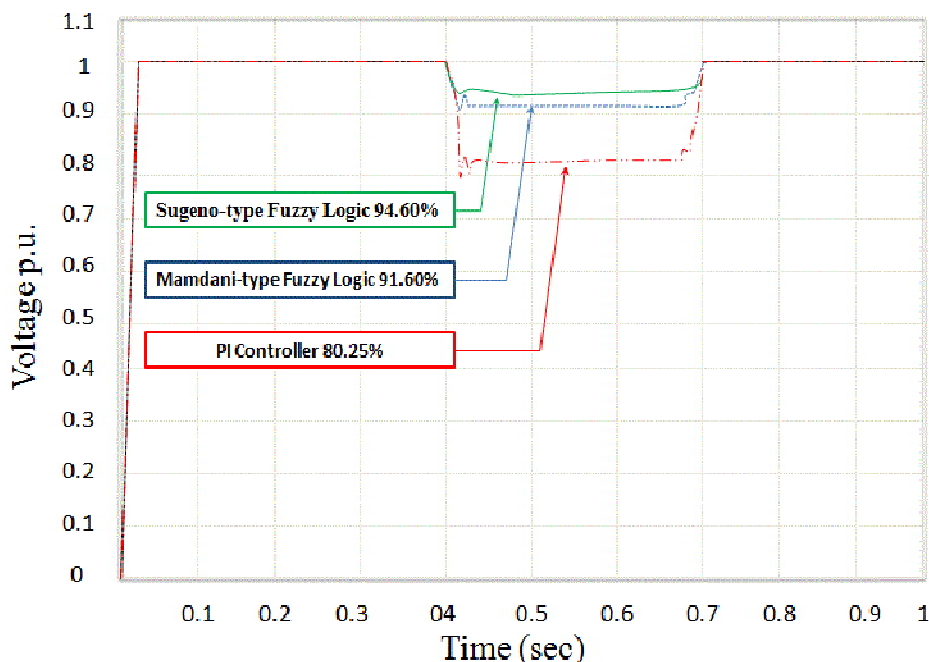

Fig. 14 (c) Three-Phase Comparison of Sugeno-Type Fuzzy Logic, Mamdani-Type Fuzzy Logic, and PI Controller In Matlab/Simulink model when the fault was introduced at the point of common coupling, voltage sag appears at the period 0.4 to 0.6 secs in the single-phase, two-phase, and three-phase were shown in figures 12 (a), 13 (b), and 14 (c).

VI. CONCLUSION

This paper presents the results of simulation on DVR using Matlab software to test dynamic voltage restorer for voltage sag problems in distribution networks based on, PI controller, Sugeno-type fuzzy logic, and Mamdani-type fuzzy logic in term of controlling unit where compared. The analysis for results showed that applying of Sugeno-type fuzzy logic and Mamdani-type fuzzy logic resulted better performances, thus proved that DVR was able to solve the problem of voltage sag on distribution network. From comparison, it can be concluded that Sugeno-type has computationally efficient which were better than Mamdani-type fuzzy logic and PI controller for solving voltage sag problem of power quality.

REFERENCES

- [1] S. Deepa, S. Rajapandian, "Implementation of dynamic voltage restorer for voltage sag mitigation," International Journal of Engineering Science and Technology Computer, vol. 2, no. 10, pp. 5825-5830, 2010.
- [2] M. M. Khaleel et al., "DVR with artificial intelligent controller for voltage sag mitigation," International Conference on Advances in Engineering and Technology, pp. 569-567, 2014.
- [3] P. Boomchiam, N. Mithulanathan, "Diode-Clamped multilevel voltage source converted based on medium voltage DVR," International Journal of Electrical power and energy system engineering, pp. 62-67, Spring, 2008.
- [4] R. Sedaghati et al., "A survey of voltage sags and voltage swell phenomena in power quality," International Journal of Scientific Research and management, vol. 1, pp. 458-462, Dec. 2013.
- [5] S. K. Chen et al., "Dynamic voltage restorer incorporating dq0," International Journal of Computer Applications., pp. 19-22, 2012.
- [6] H. Marefatjou, M. Sarvi, "Compensation of Single-phase and Three-phase Voltage sag and swell using dynamic voltage restorer," International Journal of Journal of Power Engineering, vol. 1, pp. 129-144, 2012.
- [7] A. Abdelkrim et al., "LMI-based tracking control for Takagi-Sugeno fuzzy model," International Journal of Control and Automation. vol. 3, pp. 21-36, June, 2010.



ISSN (Print) : 2320 – 3765
ISSN (Online): 2278 – 8875

International Journal of Advanced Research in Electrical, Electronics and Instrumentation Engineering

(An ISO 3297: 2007 Certified Organization)

Vol. 3, Issue 4, April 2014

BIOGRAPHY



Mohamed Mohamed Khaleel was born in 09-07-1988, Misrata, Libya. He is currently research scholar M.Sc. Eng, Dept. MEC E, Surakarta, Indonesia. His research interest includes Power System Analysis, Power Electronics, Power Quality, Control Systems, Renewable Energy, and Artificial Intelligence Systems.