

# A NEW FREEZING-ULTRAMICROTOME

H. MOOR, Ph.D., K. MÜHLETHALER, Ph.D., H. WALDNER, and  
A. FREY-WYSSLING, Ph.D.

From the Laboratory of Electron Microscopy, Department of General Botany, Swiss Federal Institute of Technology, Zürich, Switzerland

## ABSTRACT

The difficulties in sectioning frozen biological objects for electron microscopic investigations are overcome by Steere's freezing-etching method. In order to test this method and to open up a wide field of application, the new freezing-ultramicrotome has been designed. The apparatus consists of the combination of an ultramicrotome with freezing-drying and shadow-casting installations in the same vacuum container. The preliminary results show, on the one hand, the practicability of all preparational steps and, on the other, that it is possible to resolve internal structures of cell organelles and even macromolecular patterns.

## A. INTRODUCTION

In an endeavor to produce as few preparation artifacts as possible during fixation, dehydration, and embedding, investigators have repeatedly tried to section biological objects in the frozen state. In the attempt to produce such sections usable for electron microscope purposes, however, great difficulties are encountered: sections of 1000 Å thickness or less are rarely obtainable because of the brittleness of ice; the object and knife become covered with an interfering hoarfrost; and the customary collection of sections on a fluid surface is impossible because of the necessity of maintaining sections in the totally frozen condition. These problems of preparation technique can be overcome with the help of the freezing-etching method introduced by Steere (6): the frozen object is cut down to a point which is of interest; from the block surface a thin layer of ice is removed by sublimation in high vacuum, and from the object field exposed in this way a replica is obtained by means of carbon-reinforced heavy-metal shadowing. The replica is detached from the object and used for investigation in place of a thin section.

## B. THE MICROTOME

The constructive solution presented in this communication consists essentially of the combination of an ultramicrotome with freezing-drying and shadow-casting installations in the same vacuum container. For the production of a smooth surface the portion of the object which is not required must be removed as a series of thin sections. This must be done because of the physical properties of ice. For this reason a stable microtome with the finest reproducible advance mechanism has been developed. Cutting in high vacuum inhibits hoarfrosting and, together with precise vacuum and temperature measuring instruments, permits exact control of the sublimation rate. Replicas of highest resolution are obtained by using a platinum-carbon mixture as the shadowing material. This mixture also presents the essential advantage of requiring a very short evaporation time (1 to 2 seconds), and thus a minimum of radiated heat reaches the object.

The fundamental member of the freezing-ultramicrotome apparatus is a high-vacuum

evaporation unit (type BA 500) of the Gerätebau-Anstalt, Balzers, Liechtenstein (Fig. 1). Detailed sketches are shown in Figs. 4 to 7. With a built-in cold trap in the form of a cooling finger [5] for liquid air, an experimental vacuum of  $2$  to  $3 \times 10^{-6}$  mm. Hg can be obtained within an hour. The bell [30] accommodates the microtome, the freezing table, optical equipment for object observation, and two shielded evaporation units for shadowing and carbon reinforcement (Figs. 2, 3).

The microtome is supplied with as massive a support [31] as possible to ensure the stability and carrying capacity demanded by a load of about 5 kg. contributed by the microtome arm [21] and counterweight [34]. The fork [32], carried by the microtome support and fixed to the transmitting rod [35] by a leaf spring [33], transmits the advancement, reduced in a ratio of 1 to 10, over to the microtome arm. The mechanical advance (down to 1 micron) must be regulated after each cut by means of the micrometer screw [43]. The fine advance is driven continuously by slowly heating the transmitting rod [35]. A universal joint [8] with V-shaped bearings, placed in the fork, supports the hollow microtome arm (Fig. 6), which is connected by flexible metal tubing [7] with the inlet pipe [3]. This pipe enables the knife holder [25] at the lower end of the arm to be cooled with liquid air. The atmospheric pressure, acting on the microtome arm, fixes the universal joint in its bearings. A rubber O ring [27] establishes vacuum-tight relationship between the upper end of the nickel-silver inlet pipe and the bell. The use of polished razor blades

(Sjöstrand, 5) as knives is necessary to get a large sectioning area and good cold conduction to the cutting edge (angle of  $45^\circ$ ). The eccentric microtome drive [39] directs the knife holder [25], connected by means of a ball-and-socket joint [38] and double V-shaped bearings [36], in a circular path. After cutting, the cooled holder, which is constructed slightly asymmetrically, is advanced by  $30^\circ$  and overlaps the object completely in this position (dotted line in Fig. 6). Thus the very small distance (about 1 mm.) from specimen to cold trap (knife holder) provides the most excellent sublimation conditions. For lubrication of all movable parts exposed to high vacuum and low temperatures, a molybdenum sulfide grease (Spinkote No. 5056) has proved satisfactory.

The removable freezing table [26], on which the frozen object will be cut, contains one connection of a thermocouple; the second connection is placed outside the bell in an ice-water mixture. The temperature is determined by direct measurement of the thermocurrent with a galvanometer. The table is cooled by a conducting rod [17], with a tongue [19] immersed in liquid air, which is mounted in a nickel-silver insulator [16] preventing heat conduction from the base plate [40]. The regulation and variation of the object temperature down to  $-150^\circ\text{C}$ . is made possible by raising and lowering the Dewar flask [20] by means of the height adjustment [18].

A built-in optical device enables microtome adjustment and cutting to be checked. It permits observation either with the naked eye or at 5-fold

---

#### FIGURE 1

The high-vacuum evaporation unit. On the desk beside the bell the following additional instruments are placed: galvanometer, high-vacuum measuring apparatus ( $10^{-2}$  to  $10^{-8}$  mm. Hg), and the second connection of the thermocouple in an ice-water mixture.

#### FIGURE 2

Eccentric microtome drive with ball-and-socket joint and double V-shaped bearings (uncovered by removal of the plate preventing lateral displacement), knife holder, and freezing table with thermocouple connections (see also Fig. 6).

#### FIGURE 3

Total view of the microtome (without the inlet pipe) and of the shielded evaporating units for shadow casting (center left) and carbon reinforcement (center right).

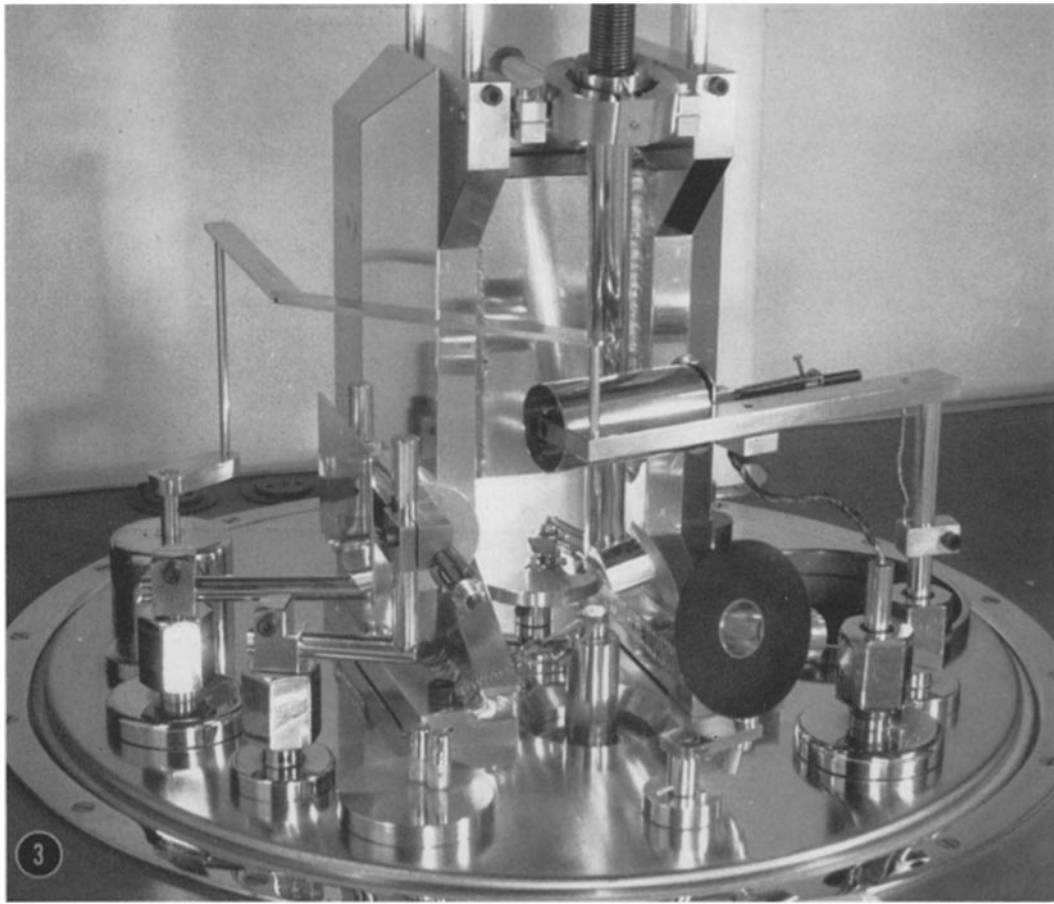
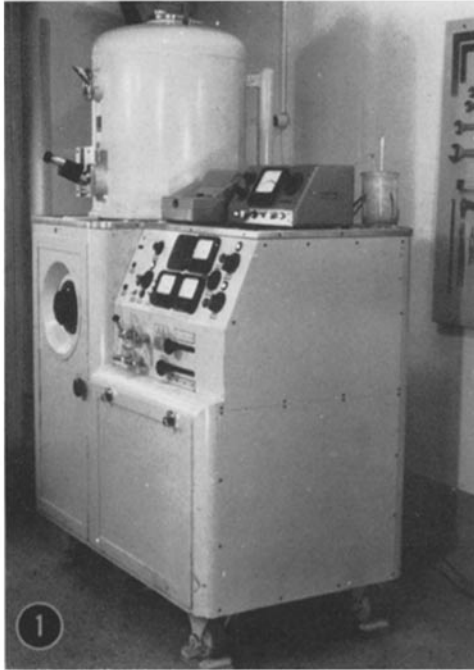

H. MOOR, K. MÜHLETHALER, H. WALDNER, AND A. FREY-WYSSLING *New Freezing-Ultramicrotome* 3

magnification by introduction of a magnifying glass [13] on a swivel support [15], and finally at 40-fold magnification by sliding a telescope [10] in its guides [9] in front of the observation window [12]. The magnifying glass is shielded [14] to prevent its contamination during the evaporation processes. The position of the illuminating lamp [37] allows object observations in the reflected light.

Both evaporating units [22, 50] belong to the same type of ordinary carbon evaporator. In order to protect the rest of the installations in the bell, they are shielded by thin-walled hollow cylinders around the electrodes [22a, 50a] focused on the object with one small aperture [22b, 50b]. With the lateral adjustable shadow-casting unit [50] evaporation angles of 15° to 60° are obtainable. Shadow casting with a platinum-carbon mixture is carried out by winding a fine platinum wire on the tips of the carbon electrodes (Moor, 2). The central unit for reinforcement of the shadow layer [22] situated perpendicularly above the freezing table [26] can be swung out of its position by means of a position control arm [48] (see arrows in Figs. 4 and 5) in order to allow the microtome arm the necessary free play during cutting.

### C. FIRST RESULTS

The first results obtained with this microtome are of technical interest and show the practicability of all preparational steps.

1. *Cutting*: Owing to the thermal fine advance it is possible to get sufficiently flat-cut faces, although the "cutting" is rather a fine splintering. Using ice only, the replicas show structureless, smooth and shell-like surfaces.

2. *Sublimation*: By exact control of the vacuum and the object temperature, any determinable

thickness of ice may be removed down to a lower limit of about 100 Å. Sublimation starts immediately after the last cutting and is interrupted by the sudden drop in vacuum at the onset of shadowing. For best experimental conditions the temperature of the object must be constant during cutting, sublimation, and shadow casting. It should not exceed by more than 10°C. the temperature of that ice whose saturation vapor pressure is equal to that of the experimental vacuum (condition for no sublimation). Higher temperatures, causing excessive rates of sublimation, hinder the condensation of the shadowing material on the object surface and prevent the formation of a continuous layer.

#### Example of Sublimation

Experimental vacuum*	$3 \times 10^{-6}$ mm.Hg
Temperature of ice with the same vapor pressure	-106°C.
Object temperature	-100°C.
Vapor pressure of ice at object temperature	$1 \times 10^{-5}$ mm. Hg
Rate of sublimation	10 A/sec. (Malmström, 1)

\* Measured with an ionization gauge (hot cathode) of the Gerätebau-Anstalt, Balzers.

Under these conditions, 1 minute and 40 seconds are thus required to remove a layer of ice 1000 Å thick. This has been proved by our experiments.

3. *Replication*: For evaporation, spectrographically pure graphite rods are used; the necessary energy is 10 volts and 40 amperes during 1 second for shadow casting and during 5 seconds for carbon reinforcement. The resulting thicknesses of the two layers are about 30 and 150 Å, respectively. The insolubility of the platinum and carbon

#### Key to Figures 4 to 7

1, guiding funnel	Führung
2, support for 3	Zuleitungsstütze
3, inlet pipe	Zuleitungsrohr
4, inlet	Einguss
5, cooling finger	Kühlfinger
6, liquid air	flüssige Luft
7, flexible metal tubing	Federkörper
8, universal joint	Kreuzgelenk
8a, outer ring	äusserer Ring
8b, inner ring	innerer Ring

9, guides for telescope	Schienen
10, telescope	Fernrohr
11, sliding piece	Schlitten
12, observation window	Beobachtungsfenster
13, magnifying glass ( $\times 5$ )	Lupe
14, shielding	Abschirmung
15, swivel support	Ausschwenkvorrichtung
16, insulator	Isolator
17, conducting rod	Kälteüberträger
18, height adjustment	Höhenverstellung
19, metal tongue	Zunge
20, Dewar flask	Dewar-Gefäss
21, microtome arm	Mikrotomarm
22, evaporating unit for carbon re- inforcement	Kohleaufdampfung
22a, shielding	Abschirmung
22b, aperture	Apertur
23, knife	Messer
24, object	Objekt
25, knife	Messerhalter
25a, position during sublimation (dotted line)	in Sublimationsstellung (punktirt)
26, freezing table with thermo- couple connections	Gefiertisch mit Thermoement- anschlüssen
27, rubber O ring	Quetschdichtung
28, inlet	Einguss
29, connecting piece	Zwischenstück
30, bell	Rezipient
31, microtome support	Mikrotomstativ
31a, strengthening support	Verstrebung
32, microtome arm supporting fork	Vorschubgabel
33, leaf spring	Blattfeder
34, counterweight	Gegengewicht
35, transmitting rod to 32	Uebertragungsstange
36, double V-shaped bearings	Doppel-V-Lager
36a, plate preventing lateral dis- placement	seitliche Fixierung
37, illuminating lamp	Beleuchtung
38, ball-and-socket joint	Kugelgelenk
39, eccentric microtome drive	Exzenter
40, base plate	Grundplatte des Vakuumbehälters
41, lead-in for illumination current	Stromdurchführung für Beleuchtung
42, main vacuum seal	Hauptdichtung
43, micrometer screw	Vorschubmikrometerschraube
44, microtome drive	Mikrotomantrieb
45, outlet to diffusion pump	Diffusionspumpenöffnung
46, return lead	Null-Leiter
47, lead-in for evaporation current	Stromdurchführung für Verdamp- fungen
48, position control arm	Einschwenkvorrichtung
49, lead-in for thermocouple cur- rent	Thermoement-Durchführung
50, shadow-casting unit	Beschattung
50a, shielding	Abschirmungen
50b, aperture	Apertur
51, blind flange	Blindflansch
52, vacuum-tight drive shaft	Drehdurchführung

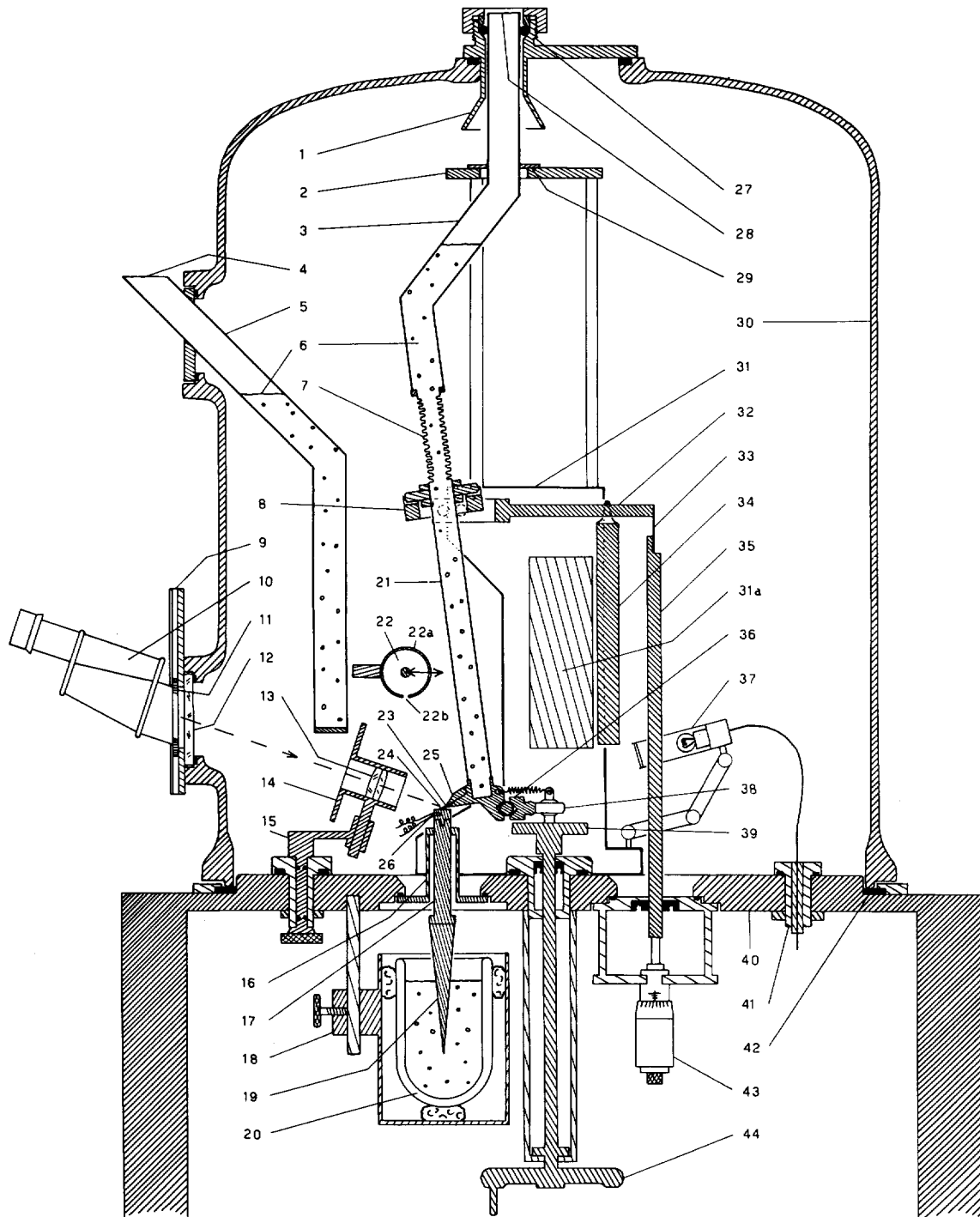

FIGURE 4  
Side view of the bell enclosing microtome, freezing table, and optical equipment (1:5).

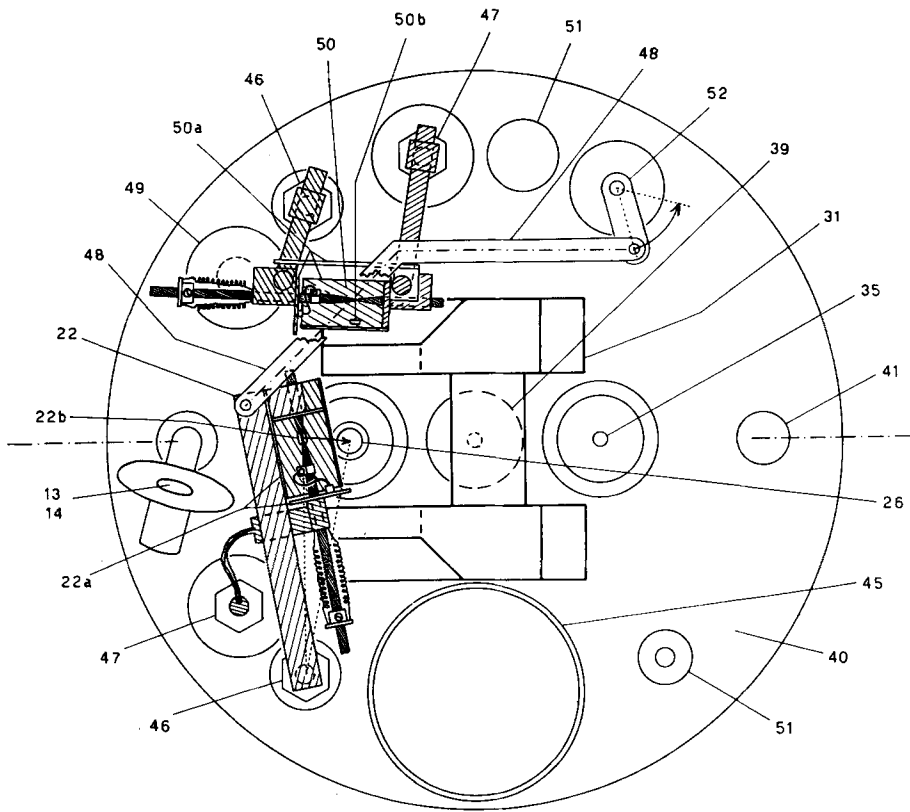

FIGURE 5  
Base plate of the bell with microtome support and evaporating units (1:5).

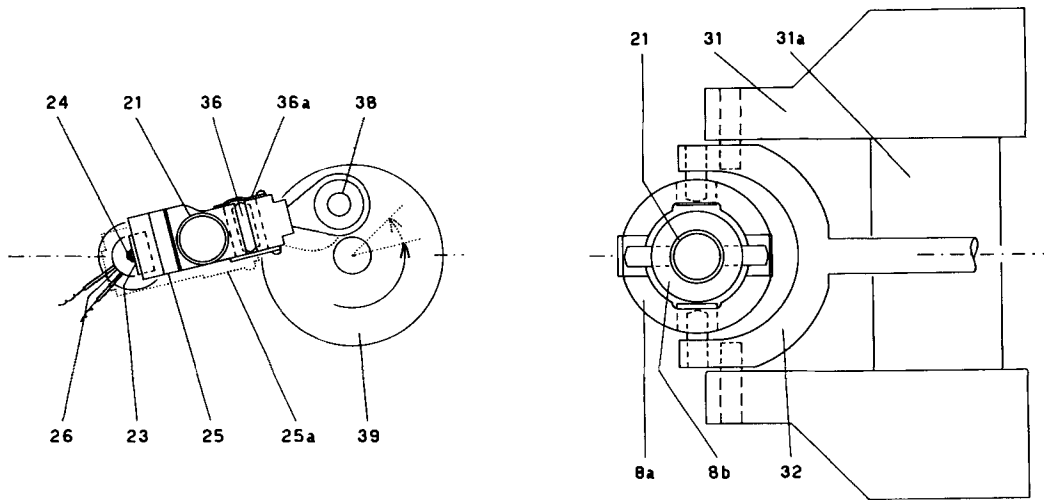

FIGURE 6  
Detailed view of eccentric microtome drive and knife holder. (1:3).

FIGURE 7  
Detailed view of the universal joint. (1:3).

enables the replica to be detached by dissolving the adhering object with strong acids (sulfuric acid 60 per cent, chromic acid 40 per cent).

4. *Problems of Application:* The surface replicas of a few frozen-etched objects shown in Figs. 8 to 15 illustrate the application of this method. In order to get an insight into the problems of interpreting the results and of developing adequate freezing techniques for biological objects, some preliminary tests have been made, using distilled water and solutions of rock salt and of sugar: as shown in Fig. 8, the etched surface of ice is covered with "warts" having a diameter of 100 to 200 Å. We have not yet been able to determine whether these forms indicate a real fine structure of ice or are caused by the inclusion of foreign particles in the crystals. It is unlikely that this structure is due to a condensation of gases remaining in the vacuum, because it does not appear under conditions for no sublimation. It is obvious that these formations may interfere with object structures of the same size.

The crucial problem which limits at present the application of freezing methods is the accompanying demixing of solutions: if the temperature is lowered below the freezing point, this process begins with the formation of ice crystals. The loss of pure water causes a concentration of the residual solution, and finally a eutectic mixture remains between the ice particles. This eutectic mixture may be crystallized as seen in a frozen 10 per cent rock salt solution (Fig. 9) or amorphous

as in a 10 per cent sugar solution (Fig. 10). The successful application of the freezing-etching method for histological and cytological investigations depends very much on the elimination or at least reduction of this demixing, because the main source of artifacts is the disorganization of the fine structure by growing ice crystals. This extensive problem, also encountered with ordinary freezing-drying methods (Müller, 4), has so far by no means been solved; but as we have already discussed elsewhere (Moor, 3), there are good possibilities of practical success.

The micrographs (Figs. 11 to 13) of cross-sections of a green alga (*Distigma*) demonstrate that the freezing-etching method is capable of showing the internal structure of cell organelles: the tubuli in mitochondria, for instance, are clearly visible (Figs. 11, 12). In the field of the investigation of nuclear structures, a new approach seems possible by our method: as seen in Fig. 13, the nucleus of a *Distigma* cell (superficially sectioned) shows a distinct network of fibrils. In certain cases we are able even to resolve macromolecular patterns, for instance, the macromolecular paracrystalline lattice of insect viral polyhedral bodies (Figs. 14, 15). These micrographs do not show the usual "shadowing" effect on the crystal surface and thus we assume that the nucleation of the shadowing material had occurred with preferential formation of nuclei in relation to the crystal structure.

---

#### FIGURES 8 TO 15

All specimens were frozen slowly on the freezing table.

##### FIGURE 8

Etched surface of frozen distilled water: the slightly visible crystal faces are covered with "warts" of unknown origin.  $\times 17,000$ .

##### FIGURE 9

Frozen-etched 10 per cent rock salt solution: between the big ice crystals lies the eutectic mixture, composed of crystallized rock salt and water.  $\times 5700$ .

##### FIGURE 10

Frozen-etched 10 per cent sugar solution: the ice crystals are surrounded by an amorphous eutectic mixture.  $\times 5700$ .



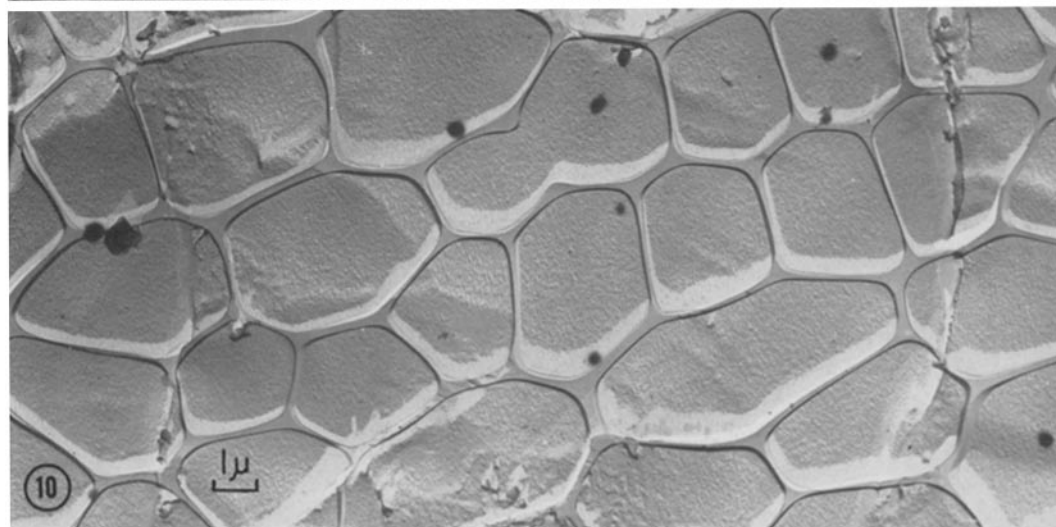
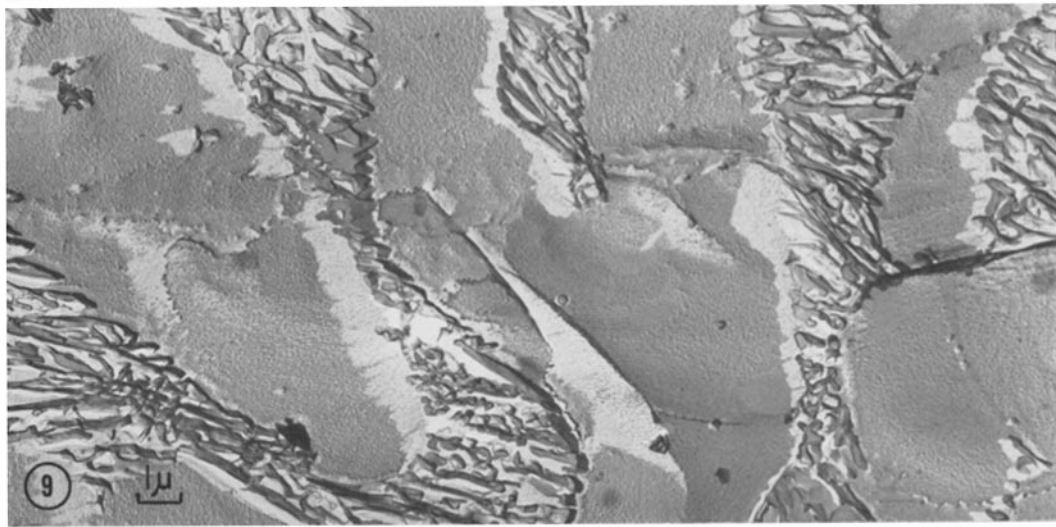
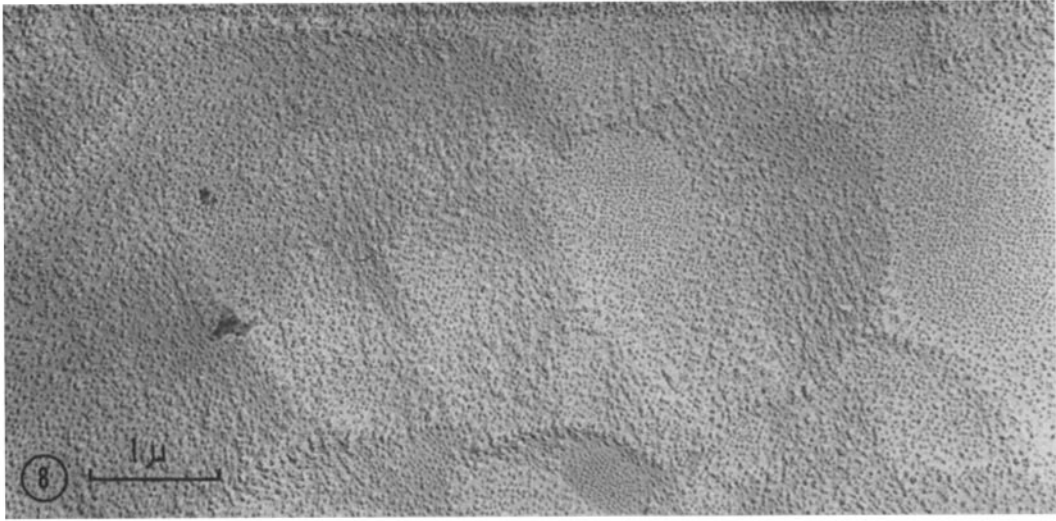

Generally, we think that this method should enable us to determine once and for all whether the freezing of tissues is as excellent for fine-structure preservation as it appears to be.

This work was supported by the Swiss National Foundation and the Jubilee Foundation of the Swiss Federal Institute of Technology.

*Received for publication, September 25, 1960.*

#### BIBLIOGRAPHY

1. MALMSTRÖM, B. G., Theoretical considerations of the rate of dehydration by histological freezing-drying, *Exp. Cell Research*, 1951, **2**, 688.
2. MOOR, H., Platin-Kohle-Abdruck-Technik, angewandt auf den Feinbau der Milchröhren, *J. Ultrastruct. Research*, 1959, **2**, 393.
3. MOOR, H., Reaktionsweisen der Pflanzen auf Kälteeinflüsse, *Beih. Z. Schweiz. Forstw.*, 1960, **30**, Festschrift Prof. Frey-Wyssling, 211.
4. MÜLLER, H. R., Die Gefriertrocknung als Fixierungsmethode für licht- und elektronenmikroskopische Untersuchungen an Pflanzenzellen, *J. Ultrastruct. Research*, 1957, **1**, 109.
5. SJÖSTRAND, F. S., Die routinemässige Herstellung von ultradünnen Gewebeschnitten für elektronenmikroskopische Untersuchungen der Gewebezellen bei hoher Auflösung, *Z. wissenschaft. Mikr.*, 1954, **62**, 65.
6. STEERE, R. L., Electron microscopy of structural detail in frozen biological specimens, *J. Biophysic. and Biochem. Cytol.*, 1957, **3**, 45.

---

#### FIGURE 11

Frozen-etched cross-section of *Distigma*. *U*, undulated membrane; *M*, mitochondria; *P*, starch grains; *V*, vacuole; *G*, ground substance.  $\times 8600$ .

#### FIGURE 12

Mitochondria with tubuli (*T*).  $\times 28,000$ .

#### FIGURE 13

A superficially sectioned nucleus.  $\times 25,000$ .

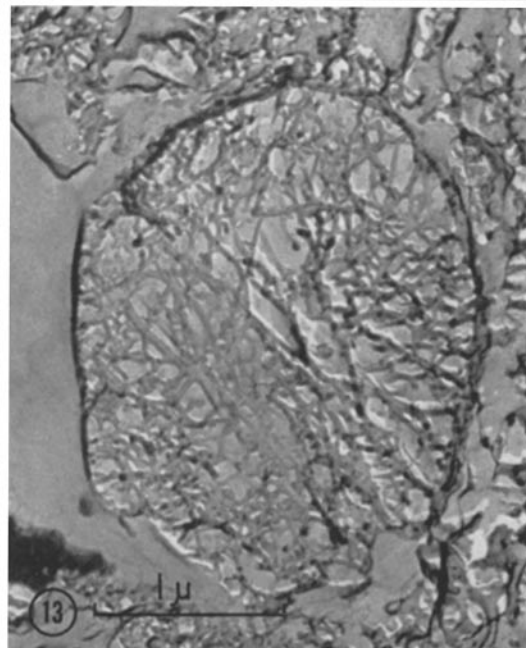
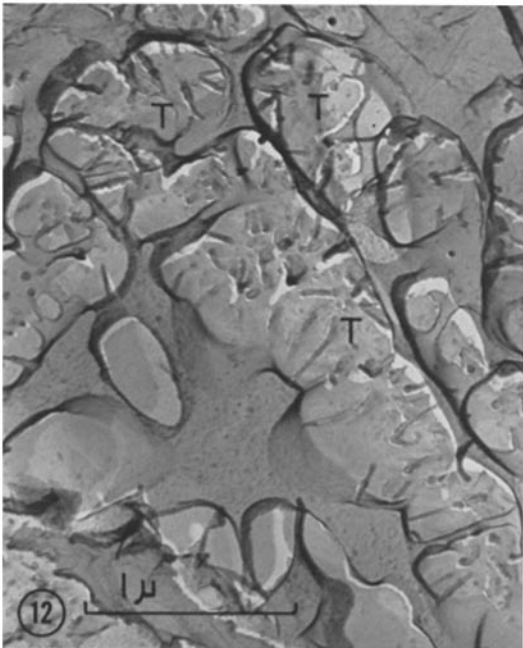
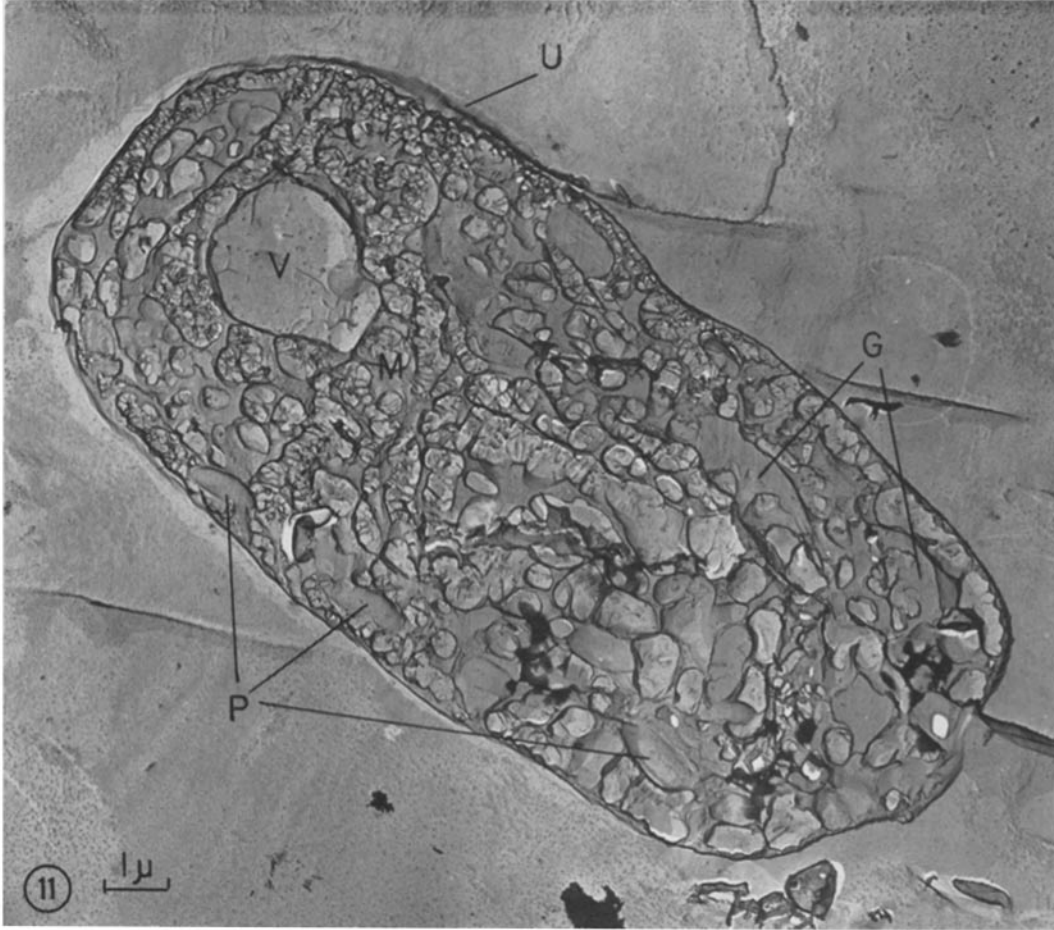

---

FIGURES 14 AND 15

Macromolecular paracrystalline lattice of insect viral polyhedral bodies.  $\times 87,000$  and  $\times 132,000$ .

