

ORIGINAL ARTICLE

Open Access



A New Method for Type Synthesis of 2R1T and 2T1R 3-DOF Redundant Actuated Parallel Mechanisms with Closed Loop Units

Yongquan Li^{1,2}, Yang Zhang^{3*} and Lijie Zhang^{2,4}

Abstract

The current type synthesis of the redundant actuated parallel mechanisms is adding active-actuated kinematic branches on the basis of the traditional parallel mechanisms, or using screw theory to perform multiple getting intersection and union to complete type synthesis. The number of redundant parallel mechanisms obtained by these two methods is limited. In this paper, based on Grassmann line geometry and Atlas method, a novel and effective method for type synthesis of redundant actuated parallel mechanisms (PMs) with closed-loop units is proposed. Firstly, the degree of freedom (DOF) and constraint line graph of the moving platform are determined successively, and redundant lines are added in constraint line graph to obtain the redundant constraint line graph and their equivalent line graph, and a branch constraint allocation scheme is formulated based on the allocation criteria. Secondly, a scheme is selected and redundant lines are added in the branch chains DOF graph to construct the redundant actuated branch chains with closed-loop units. Finally, the branch chains that meet the requirements of branch chains configuration criteria and F&C (degree of freedom & constraint) line graph are assembled. In this paper, two types of 2 rotational and 1 translational (2R1T) redundant actuated parallel mechanisms and one type of 2 translational and 1 rotational (2T1R) redundant actuated parallel mechanisms with few branches and closed-loop units were taken as examples, and 238, 92 and 15 new configurations were synthesized. All the mechanisms contain closed-loop units, and the mechanisms and the actuators both have good symmetry. Therefore, all the mechanisms have excellent comprehensive performance, in which the two rotational DOFs of the moving platform of 2R1T redundant actuated parallel mechanism can be independently controlled. The instantaneous analysis shows that all mechanisms are not instantaneous, which proves the feasibility and practicability of the method.

Keywords: Redundant actuated, Parallel mechanisms, Type synthesis, Atlas method, Instantaneous analysis

1 Introduction

Redundancy can be divided into actuated redundancy, kinematics redundancy and hybrid redundancy according to its characteristics. Kinematic redundancy has some disadvantages, which are difficult to ensure high-precision motion, difficult to control and so on. Therefore, domestic and overseas Scholars have done a lot of research work on actuated redundancy. Refs. [1–3] show

that actuated redundancy can avoid or reduce singularity and increase the workspace without singularity. Kim et al. proposed 3-PPRS 6-DOF parallel machine tool with redundant actuated (Eclipse), and it is found through research that the addition of redundant actuated can eliminate some singularities in the workspace and improve the stiffness of the system. On this basis, Eclipse Π with 360° rotation ability is developed [4]. Refs. [5–8] show that redundant actuated can effectively improve the stiffness of the mechanism. Guo et al. [9] designed a 3 DOF parallel mechanism with redundant branched chain, and established Jacobian matrix and stiffness evaluation index considering redundant actuated. Based

*Correspondence: 1623641500@qq.com

³ School of Mechanical Engineering and Automation, Harbin Institute of Technology, Shenzhen 518052, China
Full list of author information is available at the end of the article

on the stiffness evaluation index, the comparative analysis of redundant actuated parallel mechanism and non-redundant actuated parallel mechanism is carried out. It is found that redundant actuated chains can improve the stiffness in specific directions and the stiffness distribution of parallel robots. Zhao et al. [10, 11] took the 5-UPS/PRPU parallel mechanism as the research object. The redundant actuated is added to the P pair of PRPU branched chain, which can effectively eliminate the crawling defects of the intermediate slider. It can also optimize and enhance the actuated carrying capacity on each branch of the parallel mechanism.

Wu et al. [12, 13] remodeled the traditional non-redundant parallel mechanisms by adding actuated branches. 3 DOFs redundant actuated parallel mechanisms are proposed. It is found that redundant actuated can improve the performance of machine tools, and the dynamic performance of the proposed mechanism is analyzed and optimized. Han et al. [14] constructed a redundant actuated parallel mechanism by adding a PSS branch chain to the 3-PSS parallel mechanism, and the dynamics and control analysis are carried out. Make the original mechanism get larger workspace and stiffness. Gogu [15, 16] synthesized a fully isotropic redundant actuated parallel mechanism by adding redundant actuated joints with specific sport mode to the mechanism branch. Qu et al. [17] put forward a set of type synthesis theory of redundant actuated parallel mechanisms. The single-ring or multi-ring mechanism is selected as the actuated unit of the branch chain. The constraint coupling of mechanism is accomplished within the branched chain unit, so that the redundant parallel mechanisms with non-over constraint and low-order over-constraint is obtained. Type synthesis of some few DOF parallel mechanisms is accomplished by this method. The 4UPU redundant actuated parallel mechanism can be obtained by adding





a UPU-type redundant actuated chain to the 3UPU PM, which can eliminate the possible parasitic motion of the mechanism. Qu et al. [18] put forward a 4-RRS redundant spherical parallel mechanism, and analyzed its statics and rigidity. By comparing the stiffness and mechanical performance of redundant and non redundant mechanisms, it is concluded that the generalized displacement of the platform is less than that of non redundant mechanism. Li et al. [19] analyzed the internal singularity of the three translational parallel mechanisms, and the types of redundant branch chains which can eliminate singularities in three translational parallel mechanisms are synthesized by utilizing the linear correlation of helices and the linear independence of all constrained helices.

Xie et al. [20–22] synthesized the type of 1T2R, 2T1R three DOFs and four DOFs non-redundant parallel drive by using the atlas method. It uses the form of table to represent the configuration synthesis process, which is of great significance to this paper. Based on the atlas method, the author proposes a new type method of redundant driven parallel mechanism with redundant branches [23].

In summary, the redundant actuated parallel mechanism have the advantages of high stiffness, high precision, high dexterity, large workspace, large load-carrying capacity and good dynamic characteristics. Especially, the redundant actuated 2R1T and 2T1R 3 DOFs parallel mechanisms can be used in complex surface milling, riveting, welding, logistics and other applications. Therefore, the type synthesis of 2R1T and 2T1R redundant 3 DOFs parallel mechanism has great research value. Up to now, most of the redundant actuated parallel mechanisms studied by scholars are based on the experience of adding active-actuated kinematic branches on the basis of the traditional parallel mechanisms, or using screw theory to perform multiple getting intersection and union to complete type synthesis. The number of redundant parallel mechanisms obtained by these two methods is limited. Among them, redundant actuated parallel mechanisms with symmetry are less. For 2R1T and 2T1R three-DOF parallel mechanisms, most scholars [24–30] are only aimed at the type synthesis of non-redundant drive parallel mechanisms.

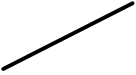
Therefore, based on Grassmann line geometry and atlas method, a new method for type synthesis of redundant actuated parallel mechanisms is proposed in this paper. This method is simple, intuitive and has clear physical meaning. This method can increase redundant drive from a view of closed-loop unit, and the number of redundant branch chains and redundant drivers can

Table 1 Elemental representation of atlas

Atlas elements	Physical significance	Helical vector type
	Force constraints	Line vector $\$^f = (\mathbf{S}; \mathbf{S}_0)$
	Couple constraint	Couple vector $\$^f = (0; \mathbf{S})$
	The rotating DOF	Line vector $\$ = (\mathbf{S}; \mathbf{S}_0)$
	The moving DOF	Couple vector $\$ = (0; \mathbf{S})$

In the table, $\f and $\$$ are the spiral expressions of constraints and movements

be selected arbitrarily according to the relevant performance indicators, and mechanisms with very good symmetry can be obtained. This method is systematic and can obtain the diversity of mechanisms in many ways. The method is also applicable to type synthesis of 2, 4, 5 and 6 DOF redundant parallel mechanisms.

This paper is organized as follows. Section 2 introduces the atlas method. Section 3 provides the synthesis method of redundant actuated parallel mechanism with closed loop units. Section 4 shows type synthesis of the first 2R1T redundant actuated parallel mechanism with both redundant branches and closed-loop units. Section 5 shows Type synthesis of the second 2R1T redundant actuated parallel mechanism with both redundant branches and closed-loop units. Section 6 shows Type synthesis of 2T1R redundant parallel mechanisms with few branched chains and closed-loop units. Section 7 gives the conclusions.

2 Introduction of Atlas Method

In order to facilitate the analysis and type synthesis of parallel mechanisms, the DOF and constraints of mechanisms are visualized, i.e., the kinematics and constraints of mechanisms are represented by line graphs composed of straight lines and double arrow lines. At present, this visualization have been applied to the related research of parallel mechanism (Singularity Analysis of Mechanisms[31], Type Synthesis of Flexible Mechanisms[32, 33]). Because this constraint and motion visualization combined with Grassmann line geometry theory makes it easier to study its dimension and lays a foundation for DOF analysis and type synthesis of parallel mechanisms. This method of describing the motion and constraints of mechanism based on line graph is called Atlas method, which realizes the visualization and graphical of screw vectors. The atlas elements are shown in Table 1, where red denotes DOF, black denotes constraints, straight lines denote line vectors, and double arrow lines denote couple.

3 Synthesis Method of Redundant Actuated Parallel Mechanism with Closed Loop Units

In this section, based on the atlas method, an effective and a simple method for the synthesis of redundant parallel mechanisms with closed-loop units is proposed. The detailed steps are shown as follows.

- (1) According to the desired target (n DOF and motion mode), draw the DOF line graph of the moving platform, and the constraint line graph dual to the DOF line graph according to the duality rule.
- (2) Constraint line graph is decomposed into several subspaces with the same dimension.
- (3) Select the number of redundant branch chains w according to the kinematic characteristics, performance indicators and task requirements of redundant actuated parallel mechanisms: for example, the fault-tolerant performance of parallel mechanisms can be improved by determining w based on fault-tolerant performance index.
- (4) According to the quantity w and layout form of redundant branch chains, add redundant lines or redundant couple to several constraint graphs of the identical dimension. The redundant quantity w and layout form of the constraint graph should meet certain rules.
 - (a) After adding redundant lines, the dimension of the line graph remains unchanged;
 - (b) After adding redundant lines, the DOF line graph dually to the constraint line graph is invariant or equivalent, so as to avoid the constraint singularity;
 - (c) Satisfies certain symmetry: because the symmetry of constraint line graph of mechanism directly affects the symmetry of branching chains and actuated symmetry, so it is very important for the comprehensive performance of mechanism.
- (5) Based on the principle of independent actuated of branched chains, select the number of branch chains as $m = n + w$.
- (6) Determine the constraint allocation scheme: divide each redundant constraint line graph with the same dimension into m groups of branch chain constraint line graphs. Because of the different allocation schemes, there are many different types of mechanism. However, some schemes may not synthesize the mechanism without instantaneity.
- (7) Choose a scheme, and determine the dually DOF graph of constraint graph of each group according to the dual rule. Subsequently, a branch-chain graph with closed-loop elements is constructed, that is to say, redundant line vectors or redundant couple quantities are added to the DOF graph according to the relevant performance indexes to obtain redundant freedoms line graphs. Similarly, adding redundancy to the DOF graph needs to satisfy the following criteria.

- (a) After adding redundant lines, the dimension of the DOF graph remains unchanged;
 - (b) After adding redundant lines, the DOF graph must be equivalent;
 - (c) Redundancy k ($k > 0$) and layout form are determined according to relevant performance indicators: for example, the symmetry of motion pairs directly affects the symmetry of actuated pairs; the number and layout of specific redundancy are determined by obtaining the index and geometric characteristics that can optimize the motor torque optimally. Because the reasonable layout forms can compensate the gap error of the motor, etc.;
 - (d) Satisfies certain geometric symmetry: the symmetry of DOF graph of closed-loop element directly affects the symmetry of mechanism branch chain and actuated of closed-loop element, which is very important for the analysis and control of mechanism.
- (8) According to the redundant DOF graph, a suitable closed-loop kinematic chain is constructed as a branch chain.
- (9) According to the F&C Atlas of the moving platform and the specific configuration requirements of the branched chains, select the appropriate branched chains and assembly the redundant actuated parallel mechanism: this step is an important step in type synthesis. For different types of redundant parallel mechanisms, the requirements of their selection and configuration are different, which need to be analyzed according to the specific mechanism. The criteria for general redundant parallel mechanisms are given as follows:
- (a) The instantaneity of the branched chain structure should be considered, because the instantaneity of the branched chain structure directly affects the instantaneity of the mechanism;
 - (b) It can satisfy the characteristic requirements of the constraint line graph of the moving platform, such as keeping the rank of the constraint line graph of the moving platform unchanged, and keeping the geometric characteristics of the constraint arrangement of each branch chain unchanged;
 - (c) It can satisfy the symmetry requirement: the more symmetrical the mechanism is, the better its comprehensive performance is;
 - (d) Considering the economy and processing possibility: the suitable pair is selected;
 - (e) Reasonable branched chains are arranged according to the DOF and geometric characteristics of the mechanism: the branched chains are arranged according to the influence of the DOF characteristics of the mechanism on some branch chains constraints, the branch chains are arranged according to the influence of the geometric characteristics of the mechanism on some branch chains constraints.
- (10) The instantaneity of the mechanism is verified by drawing the DOF graph: because the freedoms and constraints of redundant actuated parallel mechanisms are instantaneous in each position, instantaneity validation of the mechanism is necessary to ensure that the mechanism does not have instantaneity;
- (11) Analysis of institutional diversity acquisition;
- The process of this method is shown in Figure 1.

4 Type Synthesis of the First 2R1T Closed-Loop Unit Redundant Actuated Parallel Mechanism

4.1 Preliminary Synthesis of 2R1T Redundant Parallel Mechanisms with Closed-Loop Unit

Based on Grassmann line geometry theory and Blanding's rule [23], the type synthesis of 2R1T 3 DOF redundant parallel mechanisms with closed-loop elements, two rotational DOFs along the moving platform plane and one vertical translational DOF, is carried out by using the above configuration method.

According to step (1), the DOF and dual constraint line graphs of 2R1T redundant actuated parallel mechanism are obtained, as shown in Figure 2.

According to step (2), its constraint subspaces of the same dimension are obtained, as shown in Figure 3.

According to step (3), the number of redundant branches is selected to be 1.

According to step (4), we select Figure 3b to add redundant lines. Its redundant line graph is shown in Figure 4. According to Grassmann line geometry theory, two parallel line vectors are equivalent to one of the line vectors and couple vectors perpendicular to the parallel plane.

According to step (5), the number of a group of branch is selected as $M = n + w = 3 + 1 = 4$.

According to step (6), many constraint allocation schemes can be obtained, details are referred to Ref. [23],

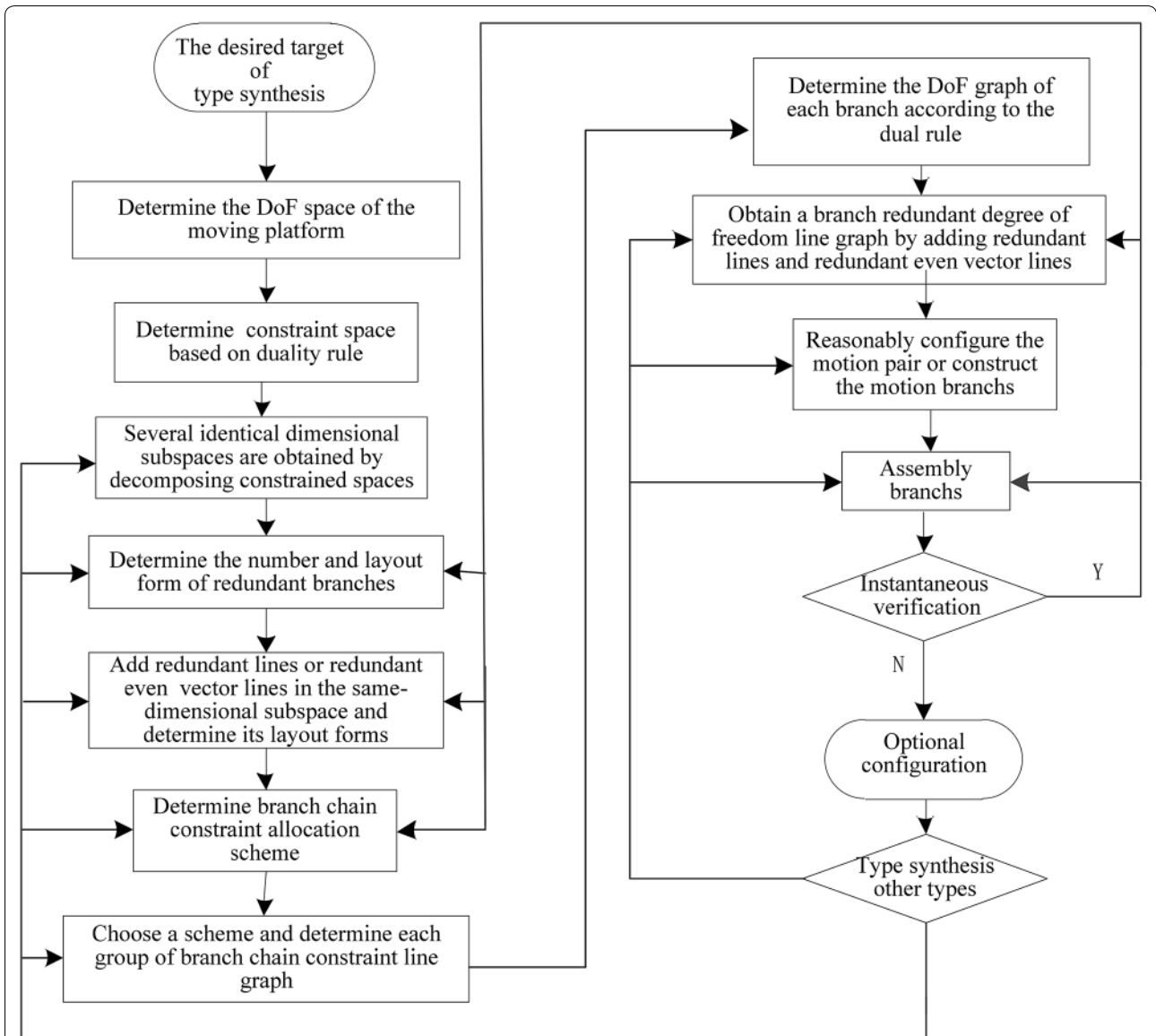

Figure 1 Type synthesis process diagram of redundant actuated parallel mechanisms

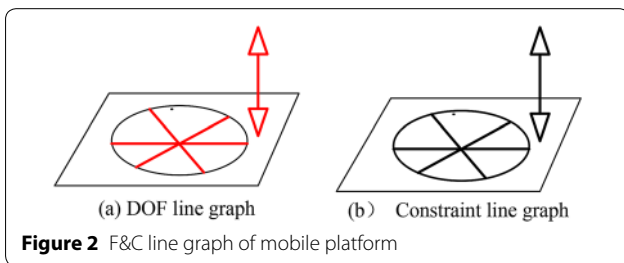

Figure 2 F&C line graph of mobile platform

and one of them is selected for example, as shown in Table 2. The mechanism consists of four branch chains. Two branch chains only provide two parallel force constraints. The other two provide two parallel force constraints and two couple constraints perpendicular to the parallel constraint plane.

Four force constraints can not be ensured to be coplanar according to the geometric characteristics and motion properties of the branched chain providing force constraints. Therefore, one pair of parallel force

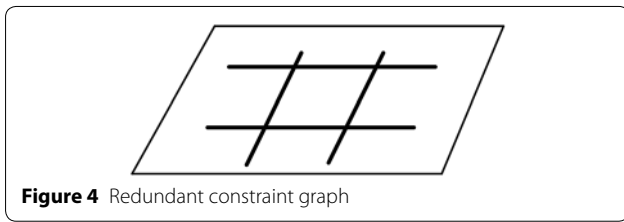
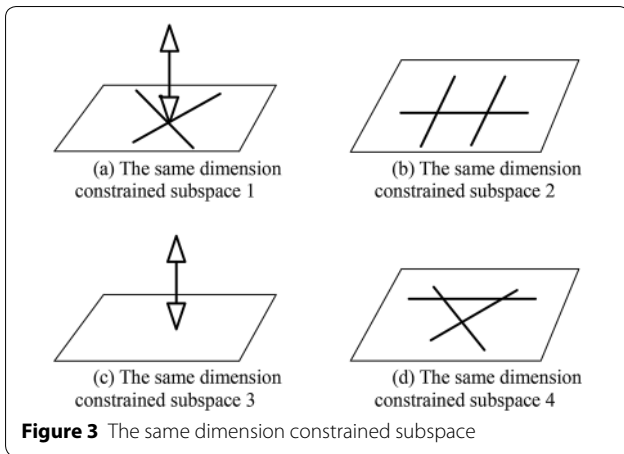
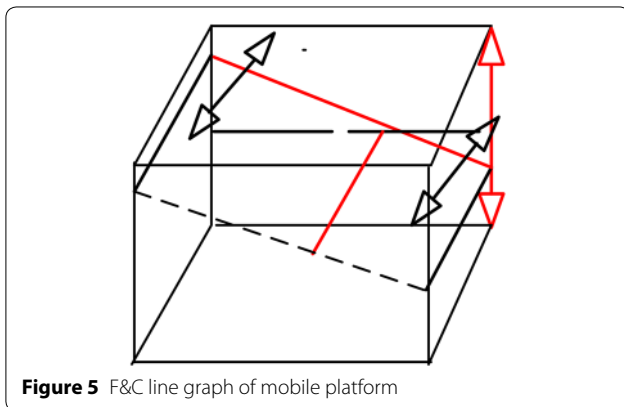
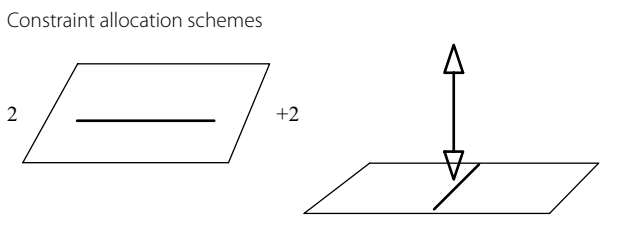

Table 2 Constraint allocation schemes



constraints need to be collinear. The specific requirements of F&C atlas of the moving platform are shown in Figure 5.

Steps (7)–(8) are shown in Table 3. According to step (9), select the appropriate branch to properly configure the motion branch, and the redundant actuated parallel mechanism is assembled according to the F&C graph of the moving platform and the specific branch configuration requirements. Some of the parallel redundant actuated mechanisms obtained by the above-mentioned schemes are shown in Table 4. The scheme synthesizes 14 fully symmetrical redundant parallel mechanisms with closed-loop units and 224 incompletely symmetrical parallel mechanisms with redundant closed-loop units. For incompletely symmetrical redundant parallel mechanisms with closed-loop branched chains, the assemblies of the representative branched chains $[(RP\bar{R}PR)_E - \bar{R}\bar{R}]$ of the first and second branched chains and the third and fourth branched chains of Table 3 are enumerated here. Other types can be obtained by replacing the other branches in the first and second chains with the third and fourth chains in Table 3, which are not listed here.

The three-dimensional diagrams of some represented parallel mechanisms in Table 4 are shown in Figure 7.

4.2 Instantaneous Verification of the First 2R1T Redundant Actuated Parallel Mechanism with Closed Loop Unit

A completely symmetric parallel mechanism $(2[(RP\bar{R}PR)_E - \bar{R}\bar{R}] - 2[(RP\bar{R}PR)_E - \bar{R}\bar{U}])$ is taken as an example to verify the instantaneity.

4.2.1 Verification of DOF Under Initial Configuration

The basic idea of analyzing the DOF of mechanism by Atlas method is consistent with that of screw theory. That is, the inverse operation of each chain motion screw system is performed to obtain the constraint screw system, and then the union operation is performed to all branches of the constraint screw system. Finally, the DOF of the mechanism can be obtained by the inverse operation of the union. Firstly, the F&C line graph of the branch chain (constraint-DOF line graph) is obtained based on the Atlas method, then the constraint line graph of the moving platform is obtained by unifying the constraints of the branch chain. Finally, the DOF line graph of the moving platform is obtained according to the duality rule. The line graph is shown in Figure 8. It can be seen from Figure 8(e) that the mechanism has two rotational DOFs rotating around the symmetry axis of the moving platform plane and the translational DOF perpendicular to the moving platform plane.

Table 3 Steps (7) ~ (8) synthesis processe

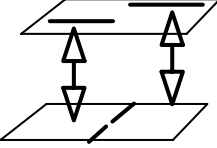
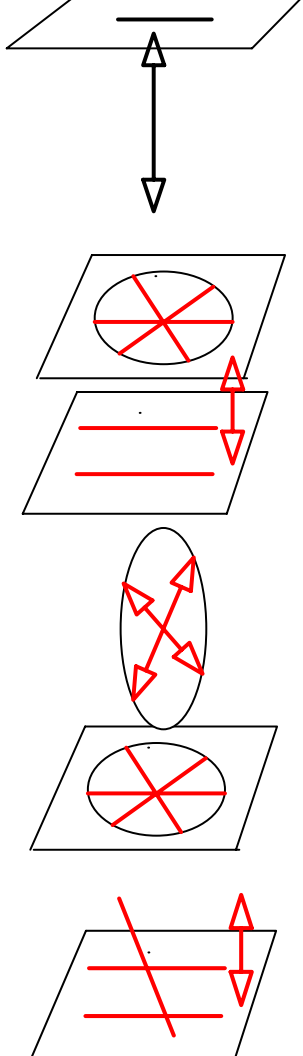
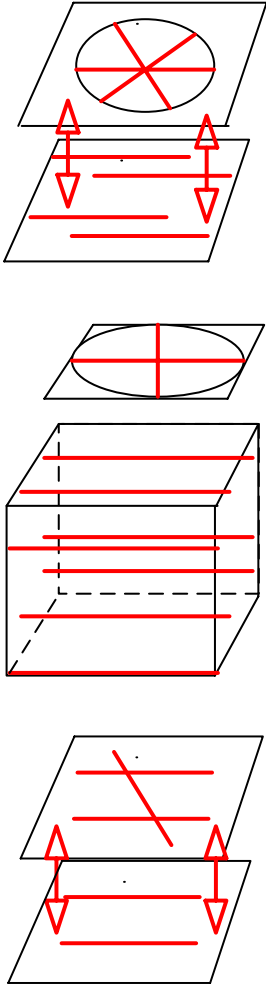
	Branch chain constraint line graph and dual DOF graph with couple	Redundant DOF graph	Corresponding branched chain structure
Chains 1 and 2			$(RR \overline{RRR})_E - \overline{RR}$ $(R \overline{PRPR})_E - \overline{RR}$ $(PR \overline{RRP})_E - \overline{RR}$ $(PP \overline{PPP})_E - \overline{RR}$ $(RR \overline{RRRR})_E - \overline{RR}$ $(PR \overline{RRRP})_E - \overline{RR}$ $(R \overline{PRRPR})_E - \overline{RR}$ $(PP \overline{RRPP})_E - \overline{RR}$ $(RRURR)_E$ $5\overline{R} - \overline{RR}$ $(PR \overline{RRP})_E - \overline{RR}$ $(R \overline{PRPR})_E - \overline{RR}$ $PR\overline{URP}$ $RP\overline{UPR}$

4.2.2 Verification of DOF Under General Configuration

The moving platform was rotated α° and β° respectively along two axes of rotational DOF, and then moved χ mm in the vertical direction. As the DOF verification under the initial position, the branch chain F&C line graph, the moving platform constraint graph and the moving platform F&C line graph are obtained as shown in Figure 9. It can be seen from Figure 9 that

in the course of two rotations and one translation, the coaxial constraints of the completely symmetric redundant actuated parallel mechanism with closed-loop are always coaxial, and parallel force constraints always remain parallel, and the couple constraints provided by that are always perpendicular to the plane

Table 3 (continued)

<p>Chains 3 and 4</p>			<p> $(RR \overline{RRR})_E - \overline{RU}$ $(R \overline{PRPR})_E - \overline{RU}$ $(P \overline{R \overline{RRP}})_E - \overline{RU}$ $(P \overline{PRPP})_E - \overline{RU}$ $\overline{RRSR \overline{R}}$ $\overline{Rps \overline{R}}$ $(RR \overline{RRR})_E - \overline{RU}$ $(PR \overline{RRR})_E - \overline{RU}$ $(R \overline{PRRRPR})_E - \overline{RU}$ $(P \overline{PRRRPP})_E - \overline{RU}$ $(RR \overline{URR})_E - \overline{R}$ $\overline{PRSR \overline{P}}$ $5R - \overline{RU}$ $(P \overline{R \overline{RRP}})_E - \overline{RU}$ $(R \overline{PRPR})_E - \overline{RU}$ $\overline{PRUR \overline{P-R}}$ $\overline{RPUP \overline{R-R}}$ </p>
<p>Branch chain assembly requirements</p>	<p> (1) The force constraint line vectors provided by 1,2 branched chains are parallel, and the force couple constraints are perpendicular to the parallel constraint plane; (2) The constraint line vector provided by 3,4 branched chains is coaxial; (3) The center of rotation of u pairs of branched chains is collinear. </p>		

In Table 3, $(RR)_E$ denotes that the axes of all rotating pairs of the same branch chain are parallel in space; $(RP)_E$ denotes that the axis of the rotating pair is perpendicular to the direction of the prismatic pair; \overline{R} denotes parallel rotating pairs in the same branch chain; \overline{R} denotes the rotating pairs intersecting in the same branch chain; \overline{R} denotes a common rotating pair in the same branch, i.e., a composite hinge. Some of the branched chains in Table 3 are shown in Figure 6.

Table 4 The first kind of mechanisms with closed loop unit redundant actuated

Symmetry	The type of mechanism
completely symmetrical	$2[(RR \bar{R} RR)_E - \bar{R}R] - 2[(RR \bar{R} RR)_E - \bar{R}U]$
	$2[(RP \bar{R} PR)_E - \bar{R}R] - 2[(RP \bar{R} PR)_E - \bar{R}U]$
	$2[(PR \bar{R} RP)_E - \bar{R}R] - 2[(PR \bar{R} RP)_E - \bar{R}U]$
	$2[(PP \bar{R} PP)_E - \bar{R}R] - 2[(PP \bar{R} PP)_E - \bar{R}U]$
	$2[5\bar{R} - \bar{R}R] - 2[5\bar{R} - \bar{R}U]$
	$2[(PR \bar{R} RP)_E - \bar{R}R] - 2[(PR \bar{R} RP)_E - \bar{R}U]$
	$2[(RP \bar{R} PR)_E - \bar{R}R] - 2[(RP \bar{R} PR)_E - \bar{R}U]$
	$2[(RR \bar{R} RR)_E - \bar{R}R] - 2[(RR \bar{R} RR)_E - \bar{R}U]$
	$[(PR \bar{R} RP)_E - \bar{R}R] - 2[(PR \bar{R} RP)_E - \bar{R}U]$
	$2[(PP \bar{R} PP)_E - \bar{R}R] - 2[(PP \bar{R} PP)_E - \bar{R}U]$
	$2[(RRURR)_E] - 2[(RRURR)_E] - R$
	$2[(PP \bar{R} PP)_E - \bar{R}R] - 2[(PP \bar{R} PP)_E - \bar{R}U]$
	$2[PR \bar{U} RP] - 2[PR \bar{U} RP - R]$
	$2[R \bar{P} U P R] - 2[R \bar{P} U P R - R]$
incompletely symmetrical	$2[(RR \bar{R} RR)_E - \bar{R}U] - 2[(RP \bar{R} PR)_E - \bar{R}R]$
	$2[(RP \bar{R} PR)_E - \bar{R}U] - 2[(RP \bar{R} PR)_E - \bar{R}R]$
	$2[(PR \bar{R} RP)_E - \bar{R}U] - 2[(RP \bar{R} PR)_E - \bar{R}R]$
	$2[(PP \bar{R} PP)_E - \bar{R}U] - 2[(RP \bar{R} PR)_E - \bar{R}R]$
	$2[\bar{R}R S \bar{R}R] - 2[(RP \bar{R} PR)_E - \bar{R}R]$
	$2[\bar{R}P S \bar{P}R] - 2[(RP \bar{R} PR)_E - \bar{R}R]$
	$2[(RR \bar{R} RR)_E - \bar{R}U] - 2[(RP \bar{R} PR)_E - \bar{R}R]$
	$2[(PR \bar{R} RP)_E - \bar{R}U] - 2[(RP \bar{R} PR)_E - \bar{R}R]$
	$2[(RP \bar{R} PR)_E - \bar{R}U] - 2[(RP \bar{R} PR)_E - \bar{R}R]$
	$2[(PP \bar{R} PP)_E - \bar{R}U] - 2[(RP \bar{R} PR)_E - \bar{R}R]$
	$2[(RRURR)_E - R] - 2[(RP \bar{R} PR)_E - \bar{R}R]$
	$2[PR \bar{S} RP] - 2[(RP \bar{R} PR)_E - \bar{R}R]$
	$2[5\bar{R} - \bar{R}U] - 2[(RP \bar{R} PR)_E - \bar{R}R]$
	$2[(PR \bar{R} RP)_E - \bar{R}U] - 2[(RP \bar{R} PR)_E - \bar{R}R]$
	$2[(RP \bar{R} PR)_E - \bar{R}U] - 2[(RP \bar{R} PR)_E - \bar{R}R]$
	$2[PR \bar{U} RP - R] - 2[(RP \bar{R} PR)_E - \bar{R}R]$
	$2[R \bar{P} U P R - R] - 2[(RP \bar{R} PR)_E - \bar{R}R]$
	⋮

of parallel force constraints, so the rank of constraint space is 3.

It can be seen from Figure 9(e) that the mechanism has two rotational DOFs rotating around the symmetry axis of the moving platform plane and one translational DOF perpendicular to the moving platform plane. So there is no instantaneity in the motion process.

5 Type Synthesis of the Second 2R1T Closed-Loop Unit Redundant Actuated Parallel Mechanism

5.1 Preliminary Synthesis of 2R1T Redundant Parallel Mechanisms with Closed-Loop Unit

Different from the previous section, this section will introduce a method to add redundant actuators on partial branch chains to guarantee some certain performance. The second 2R1T redundant parallel mechanisms with closed-loop unit are introduced as an example. The second kind of 2R1T redundant actuated parallel mechanism with closed-loop units is different from the first kind. The 2 rotational DOFs of this kind of mechanism are not coplanar, that is, they rotate around one axis of the platform and one axis of the fixed platform respectively. The DOF and constraint line graphs are shown in Figure 10.

Compared with the first kind of mechanism, the two rotational DOFs of this kind of mechanism are different, and the number and layout forms of the actuated forces in the two rotating directions are also different. When the mechanism rotates around the fixed platform, the whole mechanism will rotate along with it, and the required driving Torque is larger. Therefore, the number of actuated and the layout forms should be considered comprehensively in type synthesis. In order to satisfy the symmetry, the number of redundant branch chains is selected as 1.

Redundant actuated branches with closed-loop units are used to actuate the branches around the rotating direction of the platform to ensure the large torque, load and stability during the rotating process. The requirements of F&C graph of the moving platform during the motion of the mechanism are shown in Figure 11. How the relationship between the constraints in Figure 11 is guaranteed in the course of motion is explained in detail in Ref. [23]. Similarly, the step (7)–(8) process is shown in Table 5.

According to step (9), the appropriate branching chain is selected to reasonably configure the motion branching chain, and the redundant actuated parallel mechanism is assembled according to the F&C graph of the moving platform and the specific requirements of the

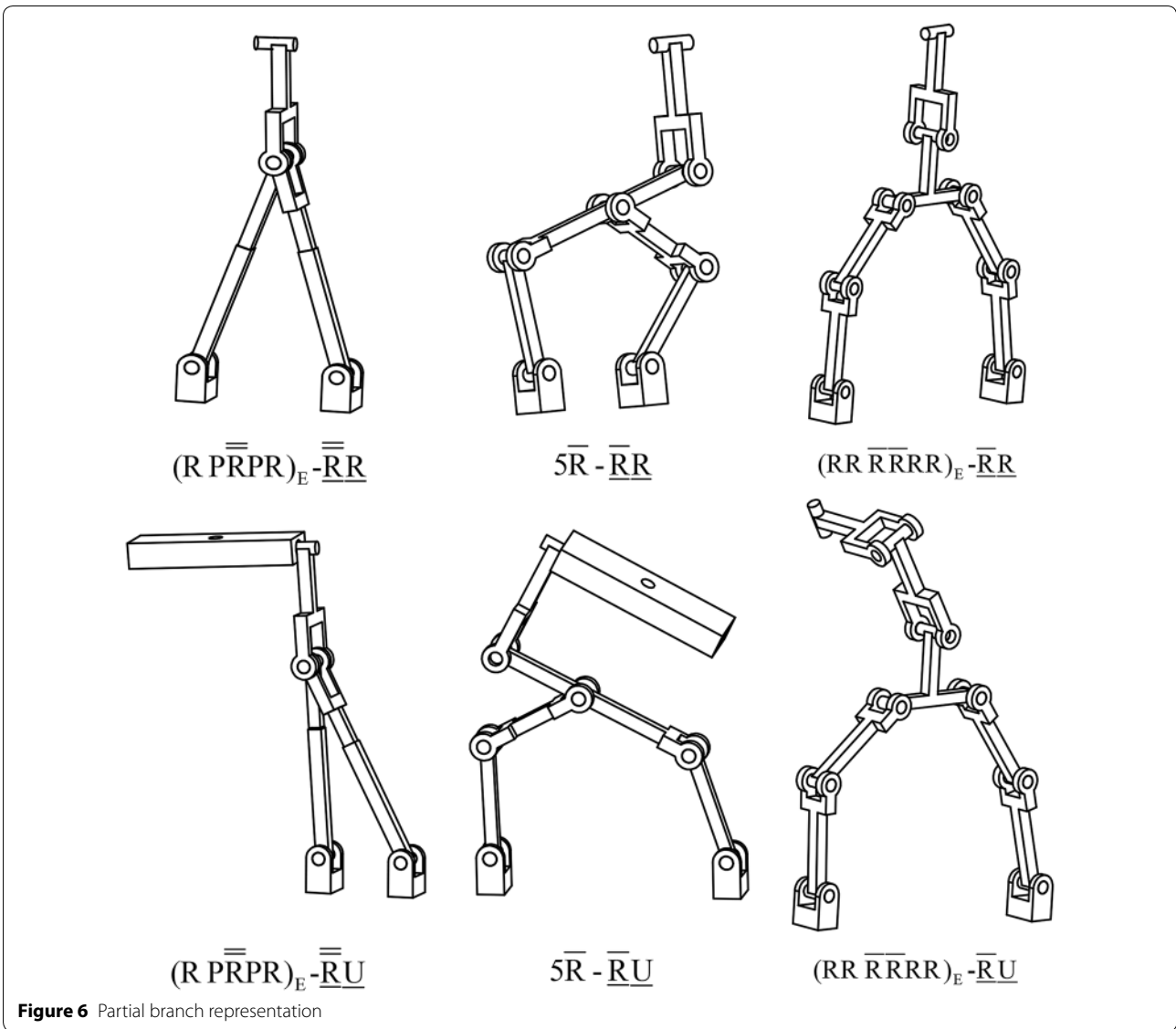

Figure 6 Partial branch representation

configuration. Some of the mechanisms synthesized by the above schemes are shown in Table 6. The three-dimensional diagram of some represented parallel mechanisms in Table 6 is shown from Figure 12.

5.2 Instantaneous Verification of the Second 2R1T Redundant Actuated Parallel Mechanism with Closed Loop Unit

A parallel mechanism with closed loop redundant actuated $(2[(R\overline{P}\overline{R}P\overline{R})_E - \overline{R}\overline{R}] - 2R(R\overline{P}\overline{R})_E)$ is taken as an example to verify the instantaneity.

5.2.1 Verification of DOF under Initial Configuration

Firstly, the F&C line graph of the branch chain is obtained based on the Atlas method, then the constraint line graph of the moving platform is obtained by unifying the constraints of the branch chain. Finally, the DOF line graph of the moving platform is obtained according to the duality rule. The line graph is shown in Figure 13. It can be seen from Figure 13(e) that the mechanism has two rotational DOFs along the symmetrical axis of the moving platform and the fixed platform plane, and one translational DOF perpendicular to the moving platform plane.

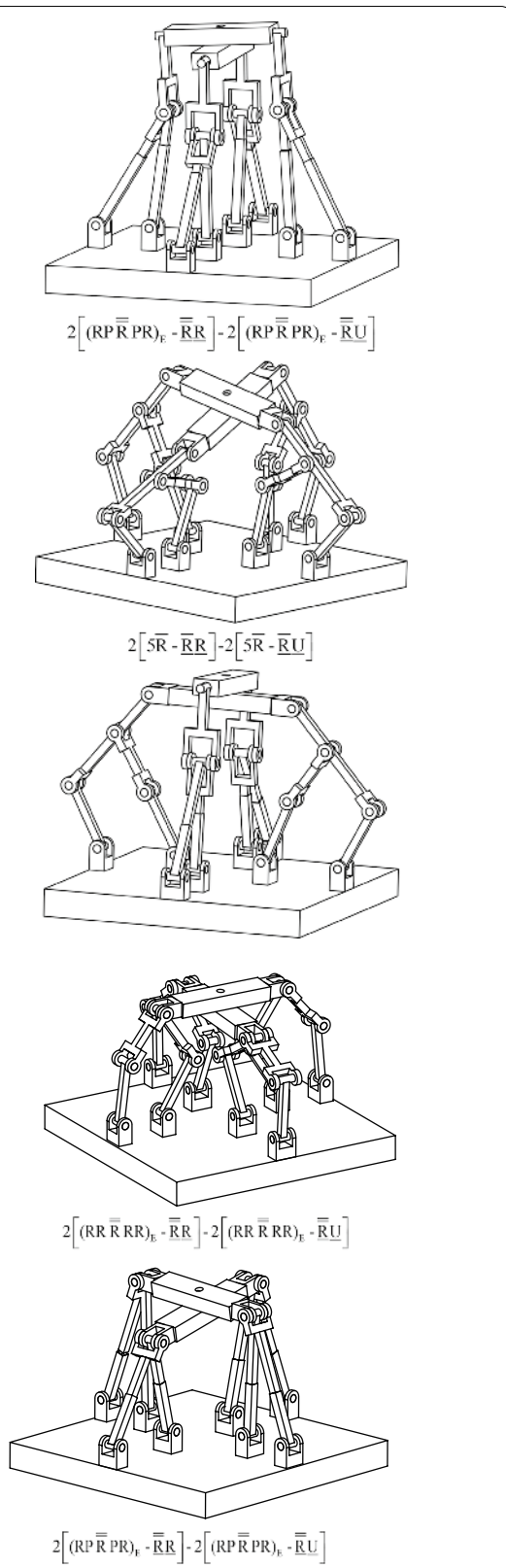

Figure 7 three-dimensional diagram of some represented parallel mechanisms

5.2.2 Verification of DOF Under General Configuration

The moving platform was rotated α° and β° respectively along two axes of rotational DOF, and then moved χ mm in the vertical direction. As the DOF verification under the initial position, the branch chain F&C line graph, the moving platform constraint graph and the moving platform F&C line graph are obtained as shown in Figure 14. It can be seen from Figure 14 that in the course of two rotations and one translation, the force constraint line vectors provided by 1, 2 branched chains are parallel and located on the moving platform. The force couple constraints provided by the branched chains are perpendicular to the parallel constraint plane. The force constraint line vectors provided by 3, 4 branched chains are parallel and located on the fixed platform. The force couple constraints provided by the branched chains are perpendicular to the parallel constraint plane. The plane of force constraint line vector provided by 1, 2 branched chains is parallel to that provided by 3, 4 branched chains. All couple constraints are parallel. According to Grassmann line geometry theory, the rank of the constraint space is always 3. It can be seen from Figure 14(e) that the mechanism has two rotational DOFs along the symmetrical axis of the moving platform and the fixed platform plane, and the translational DOF perpendicular to the moving platform plane. So there is no instantaneity in motion process.

6 Type Synthesis of 2T1R Redundant Parallel Mechanisms with Few Branched Chains and Closed-Loop Units

6.1 Preliminary Synthesis of 2T1R Redundant Parallel Mechanisms with Few Branched Chains and Closed-Loop Units

The 2T1R parallel mechanisms can be divided into three categories according to the motion characteristics of the platform: the plane formed by the directions of two translational DOF and the axis direction of rotational DOF may be vertical, coplanar and neither vertical nor coplanar. The 2T1R mechanisms are widely used in the parallel module of 5-axis hybrid milling machine, which can further improve the flexibility of the hybrid equipment and realize one-time clamping and five-sided processing. Compared with 2R1T redundant actuated parallel mechanism, there is no coupling problem of two rotations, which is more practical for the rotational requirement of equipment. Five-axis machining is possible by matching two rotating series modules. In the first two sections, redundant parallel mechanisms with both redundant branched-chain actuated and closed-loop unit

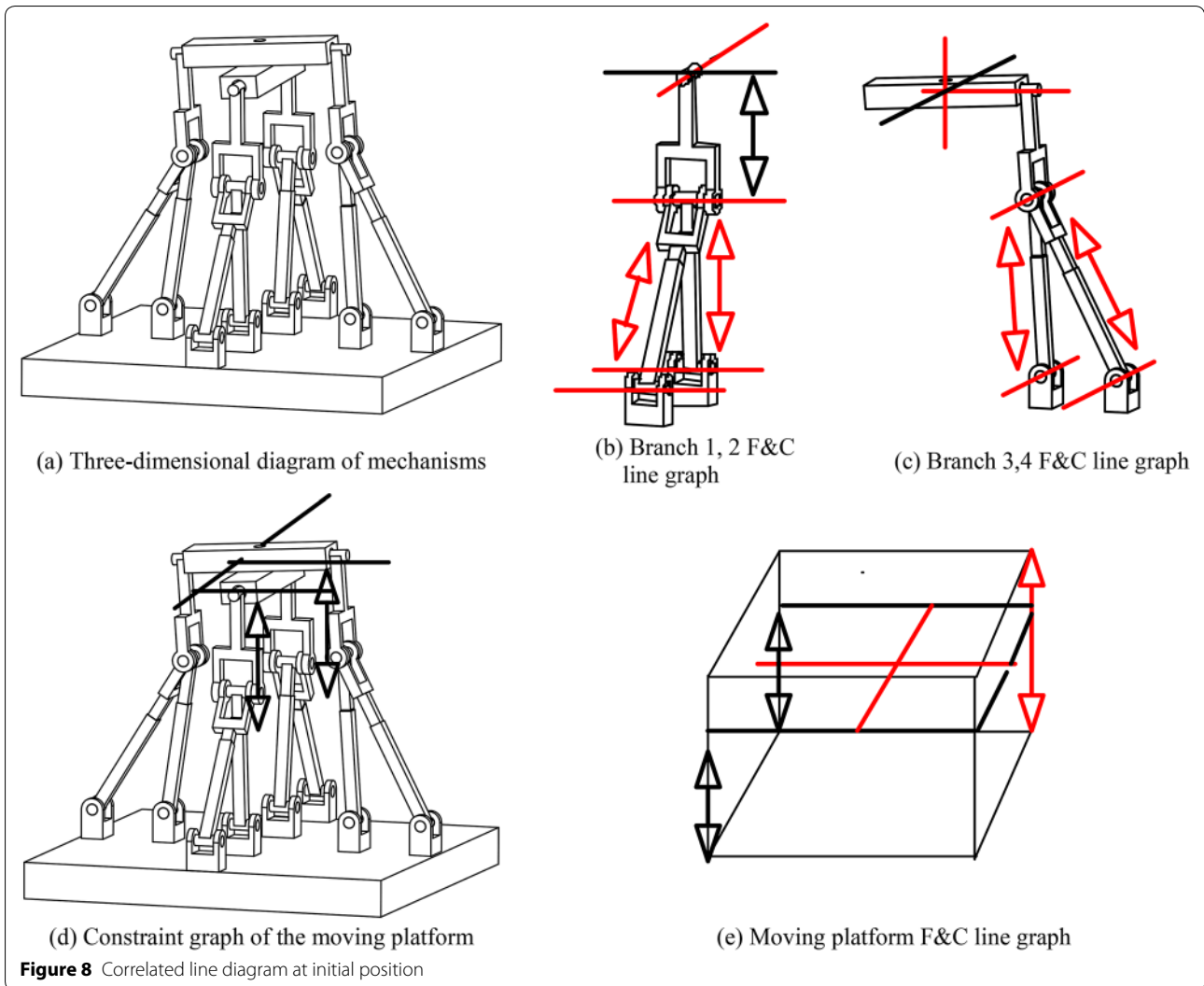

actuated are synthesized. In this section, taking the first 2T1R parallel mechanisms as an example, the redundant parallel synthesis of few branch chains with closed-loop units is introduced.

Firstly, according to step 1, the DOF and dual constraint lines of 2T1R redundant actuated parallel mechanisms are obtained, as shown in Figure 15.

According to step (2), the identical dimension constraint subspace is obtained, as shown in Figure 16.

According to step (4), Figure 16(b) is selected for discussion. According to the motion characteristics of this mechanism, 2 branches with redundant actuated can achieve 2T1R DOF motion.

According to step (6), the constraint allocation scheme shown in Table 7 is selected here.

In order to ensure the 2T1R DOF and the symmetry of the mechanism, the force constraints provided by the two branches need to be parallel in space. The force constraints provided by each branch chains are perpendicular to the plane formed by the two couple constraints provided by the branch chain. The specific requirements of the F& C Atlas of the moving platform are shown in Figure 17. Steps (7)–(8) are shown in Table 8.

According to step (9), the appropriate branching chain is selected to reasonably configure the motion branching chain, and the redundant actuated parallel mechanism is assembled according to the F&C graph of the moving platform and the specific requirements of the branching

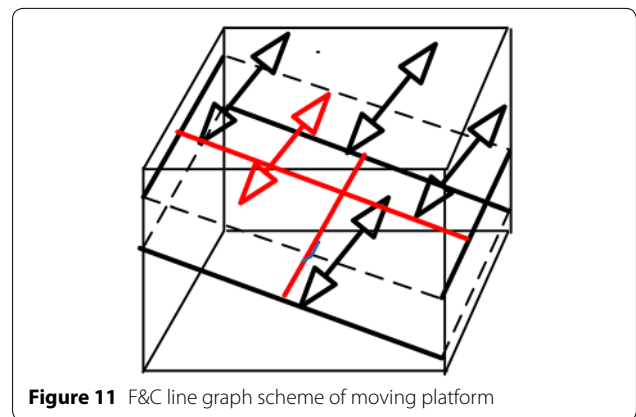
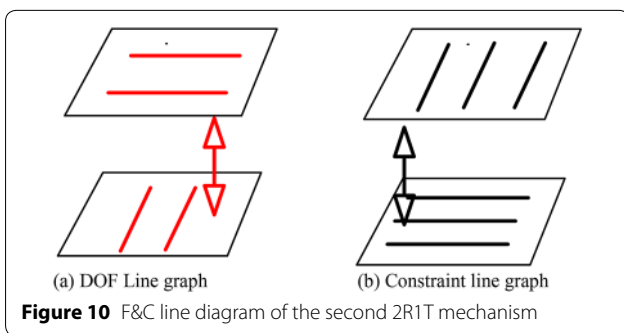
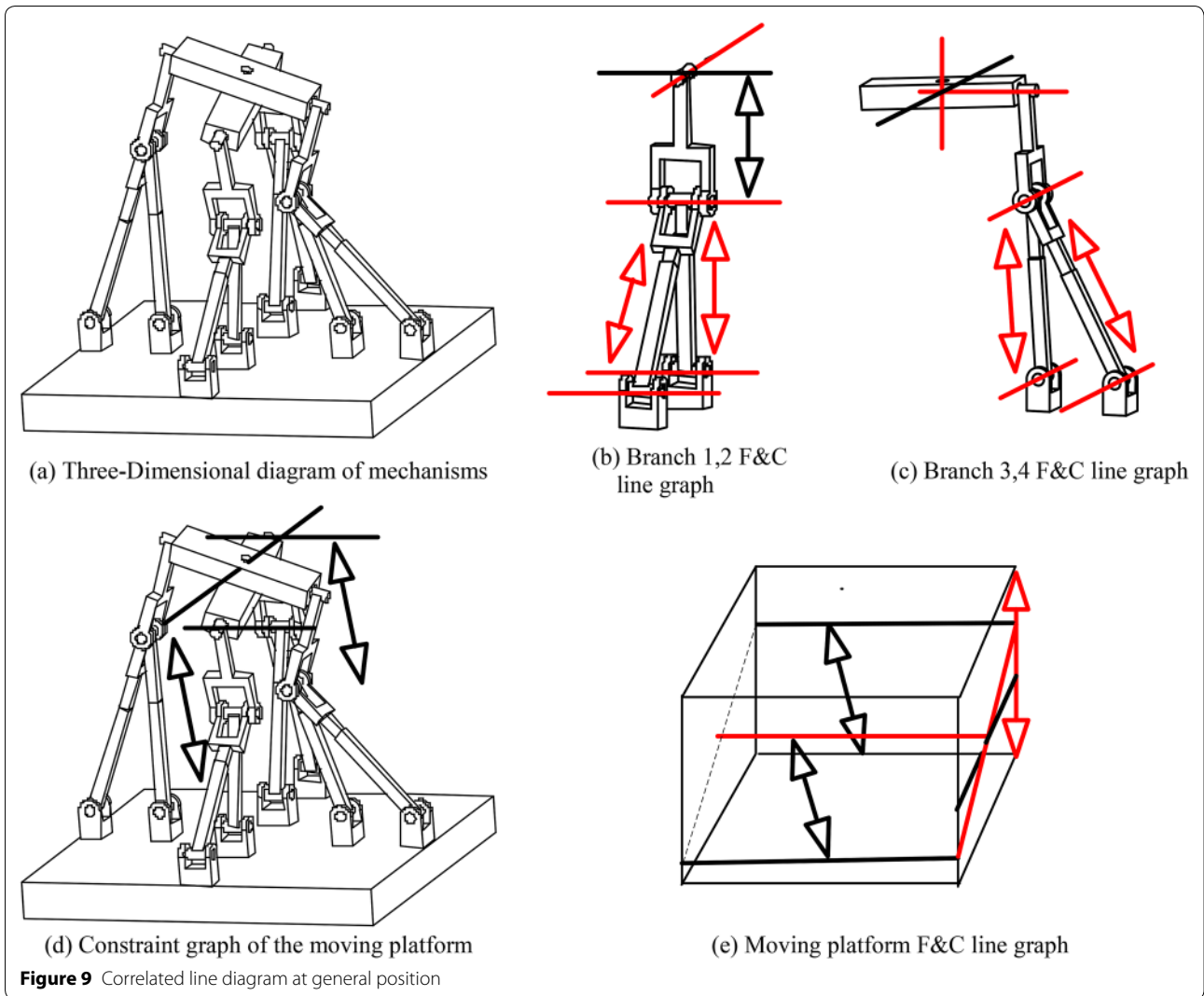

Table 5 Steps (7) ~ (8) synthesis process

	<p>Branch chain dual DOF graph with couple</p>	<p>Redundant DOF graph</p>	<p>Corresponding branched chain structure</p>
<p>Chains 1 and 2</p> 			<p> $(RR \bar{R}RR)_E - \bar{R}R$ $(R \bar{P}RPR)_E - \bar{R}R$ $(PR \bar{R}RP)_E - \bar{R}R$ $(PP\bar{R}PP)_E - \bar{R}R$ $(RR \bar{R}RRR)_E - \bar{R}R$ $(PR \bar{R}RRP)_E - \bar{R}R$ $(R \bar{P}R\bar{R}PR)_E - \bar{R}R$ $(PP\bar{R}RRP)_E - \bar{R}R$ $(RRURR)_E$ $5\bar{R} - \bar{R}R$ $(PR \bar{R}RP)_E - \bar{R}R$ $(R \bar{P}RPR)_E - \bar{R}R$ $PR\bar{U}RP$ $RP\bar{U}PR$ </p>

Table 5 (continued)

 <p>Chains 3 and 4</p>		<p>No redundancy</p>	$(RR \underline{R})_E \underline{R}$ \overline{RRU} \overline{RUR} \overline{URR} $\underline{R}(\underline{R} \underline{RP})_E$ $\underline{R}(\underline{R} \underline{PR})_E$ URP UPR PUR PRU $\underline{R}(\underline{R} \underline{PP})_E$ UPP $(PRR)_E \underline{R}$ $\underline{R}(P \underline{R} \underline{R})_E$ $(RPR)_E \underline{R}$ $R(RPR)_E$ $(RRP)_E \underline{R}$ $R(RRP)_E$ $R(P \underline{RP})_E$ $R(R \underline{P} \underline{P})_E$
<p>Branch chain assembly requirements</p>	<p>(1) The force constraint line vectors provided by 1,2 branched chains are parallel and located on the moving platform. The force couple constraints provided by the branched chains are perpendicular to the parallel constraint plane. (2) The force constraint line vectors provided by 3,4 branched chains are parallel and located on the fixed platform. The force couple constraints provided by the branched chains are perpendicular to the parallel constraint plane. (3) The plane of force constraint line vector provided by 1,2 branched chains is parallel to that provided by 3,4 branched chains. (4) All couple constraints are parallel.</p>		

chain configuration. Only two symmetrical branches are listed here. Some of the mechanisms synthesized by the above scheme are shown in Table 9.

The three-dimensional diagram of some represented parallel mechanisms in Table 5 is shown from Figure 18.

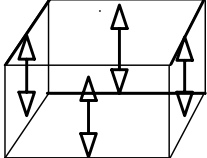
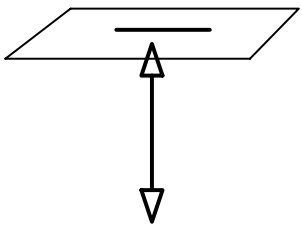
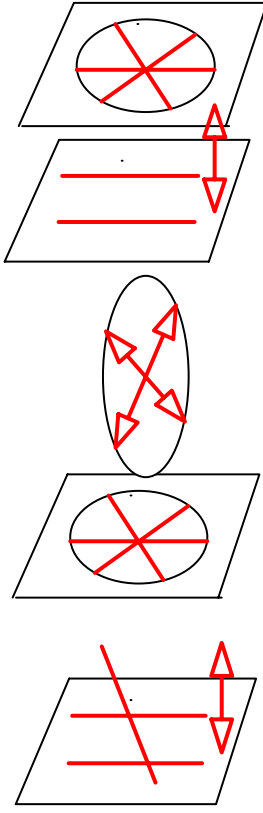
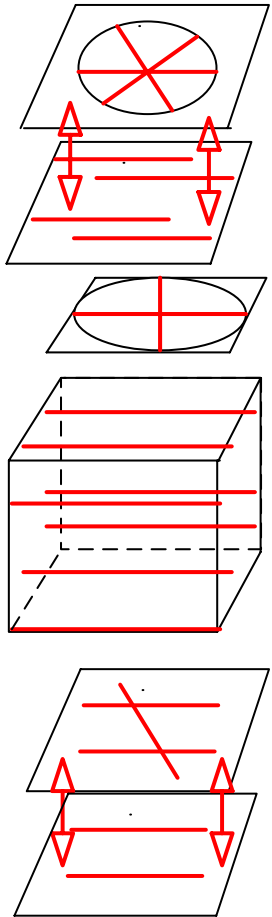
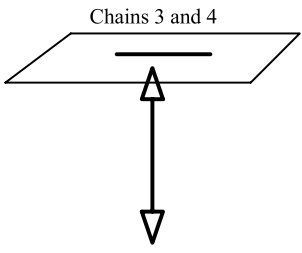
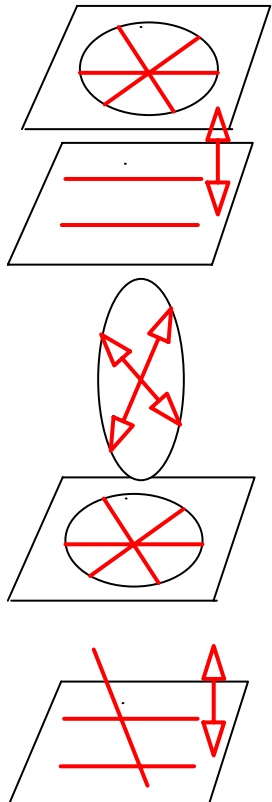
6.2 Instantaneous Verification of 2T1R Redundant Parallel Mechanisms with Few Branched Chains and Closed-Loop Units

A completely symmetric parallel mechanism with few branched chains and closed-loop units ($2[5\underline{R} - \underline{R}]$) is taken as an example to verify the instantaneity.

6.2.1 Verification of DOF Under Initial Configuration

Firstly, the F&C line graph of the branch chain is obtained based on the Atlas method, then the constraint line graph

of the moving platform is obtained by unifying the constraints of the branch chain. Finally, the DOF line graph of the moving platform is obtained according to the duality rule. The line graph is shown in Figure 19. It can be seen from Figure 19(d) that the mechanism has two translational DOFs in the vertical plane and one rotational DOF perpendicular to the vertical plane.

6.2.2 Verification of DOF Under General Configuration

The moving platform is moved κ and λ mm along the direction of two translational DOFs, and then rotated ω° along the direction of rotation. As the DOF verification under the initial position, the branch chain F&C line graph, the moving platform constraint graph and

Table 6 The second type PMs with closed loop unit

The second type PMs with closed loop unit	
$2[(RR\bar{R}RR)_E - \bar{R}R] - 2\bar{U}RR$	$2[(RRRRR)_E - \bar{R}R] - 2\bar{U}RR$
$2[(RP\bar{R}PR)_E - \bar{R}R] - 2\bar{U}RR$	$2[(PRRRR)_E - \bar{R}R] - 2\bar{U}RR$
$2[(PR\bar{R}RP)_E - \bar{R}R] - 2\bar{U}RR$	$2[(PPRRP)_E - \bar{R}R] - 2\bar{U}RR$
$2[(PP\bar{R}PP)_E - \bar{R}R] - 2\bar{U}RR$	$2[(RRURR)_E] - 2\bar{U}RR$
$2[5R - \bar{R}R] - 2\bar{U}RR$	$2[(PPRRP)_E - \bar{R}R] - 2\bar{U}RR$
$2[(PRRRR)_E - \bar{R}R] - 2\bar{U}RR$	$2[P\bar{R}U\bar{R}P] - 2\bar{U}RR$
$2[(RP\bar{R}PR)_E - \bar{R}R] - 2\bar{U}RR$	$2[RP\bar{U}PR] - 2\bar{U}RR$
$2[(RP\bar{R}PR)_E - \bar{R}R] - 2\bar{U}PR$	$2[(RRRRR)_E - \bar{R}R] - 2\bar{U}PR$
$2[(PR\bar{R}RP)_E - \bar{R}R] - 2\bar{U}PR$	$2[(RRRRR)_E - \bar{R}R] - 2\bar{U}PR$
$2[(PP\bar{R}PP)_E - \bar{R}R] - 2\bar{U}PR$	$2[(PRRRR)_E - \bar{R}R] - 2\bar{U}PR$
$2[5R - \bar{R}R] - 2\bar{U}PR$	$2[(PPRRP)_E - \bar{R}R] - 2\bar{U}PR$
$2[(PRRRR)_E - \bar{R}R] - 2\bar{U}PR$	$2[(RRURR)_E] - 2\bar{U}PR$
$2[(RP\bar{R}PR)_E - \bar{R}R] - 2\bar{U}PR$	$2[(PPRRP)_E - \bar{R}R] - 2\bar{U}PR$
$2[(RRRRR)_E - \bar{R}R] - 2\bar{U}RP$	$2[P\bar{R}U\bar{R}P] - 2\bar{U}PR$
$2[(RP\bar{R}PR)_E - \bar{R}R] - 2\bar{U}RP$	$2[RP\bar{U}PR] - 2\bar{U}PR$
$2[(PR\bar{R}RP)_E - \bar{R}R] - 2\bar{U}RP$	$2[(RRRRR)_E - \bar{R}R] - 2\bar{U}RP$
$2[(PP\bar{R}PP)_E - \bar{R}R] - 2\bar{U}RP$	$2[(PRRRR)_E - \bar{R}R] - 2\bar{U}RP$
$2[5R - \bar{R}R] - 2\bar{U}RP$	$2[(PPRRP)_E - \bar{R}R] - 2\bar{U}RP$
$2[(PRRRR)_E - \bar{R}R] - 2\bar{U}RP$	$2[(RRURR)_E] - 2\bar{U}RP$
$2[(RP\bar{R}PR)_E - \bar{R}R] - 2\bar{U}RP$	$2[(PPRRP)_E - \bar{R}R] - 2\bar{U}RP$
$2[(RRRRR)_E - \bar{R}R] - 2R(RRP)_E$	$2[P\bar{R}U\bar{R}P] - 2\bar{U}RP$
$2[(RP\bar{R}PR)_E - \bar{R}R] - 2R(RRP)_E$	$2[RP\bar{U}PR] - 2\bar{U}RP$
$2[(PR\bar{R}RP)_E - \bar{R}R] - 2R(RRP)_E$	$2[(RRRRR)_E - \bar{R}R] - 2R(RRP)_E$
$2[(PP\bar{R}PP)_E - \bar{R}R] - 2R(RRP)_E$	$2[(PRRRR)_E - \bar{R}R] - 2R(RRP)_E$
$2[5R - \bar{R}R] - 2R(RRP)_E$	$2[(PPRRP)_E - \bar{R}R] - 2R(RRP)_E$
$2[(PRRRR)_E - \bar{R}R] - 2R(RRP)_E$	$2[(RRURR)_E] - 2R(RRP)_E$
$2[(RRRRR)_E - \bar{R}R] - 2R(RRP)_E$	$2[(PPRRP)_E - \bar{R}R] - 2R(RRP)_E$
$2[(RP\bar{R}PR)_E - \bar{R}R] - 2R(RRP)_E$	$2[P\bar{R}U\bar{R}P] - 2R(RRP)_E$
$2[(PR\bar{R}RP)_E - \bar{R}R] - 2R(RRP)_E$	$2[RP\bar{U}PR] - 2R(RRP)_E$
$2[(PP\bar{R}PP)_E - \bar{R}R] - 2R(RRP)_E$	$2[(RRRRR)_E - \bar{R}R] - 2R(RRP)_E$
$2[5R - \bar{R}R] - 2R(RRP)_E$	$2[(PRRRR)_E - \bar{R}R] - 2R(RRP)_E$
$2[(PRRRR)_E - \bar{R}R] - 2R(RRP)_E$	$2[(PPRRP)_E - \bar{R}R] - 2R(RRP)_E$
$2[(RP\bar{R}PR)_E - \bar{R}R] - 2R(RRP)_E$	$2[(RRURR)_E] - 2R(RRP)_E$
$2[(PR\bar{R}RP)_E - \bar{R}R] - 2R(RRP)_E$	$2[(PPRRP)_E - \bar{R}R] - 2R(RRP)_E$
$2[(PP\bar{R}PP)_E - \bar{R}R] - 2R(RRP)_E$	$2[P\bar{R}U\bar{R}P] - 2R(RRP)_E$
$2[5R - \bar{R}R] - 2R(RRP)_E$	$2[RP\bar{U}PR] - 2R(RRP)_E$
$2[(PRRRR)_E - \bar{R}R] - 2R(RRP)_E$	$2[(RRR\bar{R}RR)_E - \bar{R}R] - 2R(RRP)_E$
$2[(RRRRR)_E - \bar{R}R] - 2R(RRP)_E$	$2[(PRRRR)_E - \bar{R}R] - 2R(RRP)_E$
$2[(RP\bar{R}PR)_E - \bar{R}R] - 2R(RRP)_E$	$2[(PPRRP)_E - \bar{R}R] - 2R(RRP)_E$
$2[(PR\bar{R}RP)_E - \bar{R}R] - 2R(RRP)_E$	$2[(RRURR)_E] - 2R(RRP)_E$
$2[(PP\bar{R}PP)_E - \bar{R}R] - 2R(RRP)_E$	$2[(PPRRP)_E - \bar{R}R] - 2R(RRP)_E$
$2[5R - \bar{R}R] - 2R(RRP)_E$	$2[PRURP] - 2R(RRP)_E$
$2[(PRRRR)_E - \bar{R}R] - 2R(RRP)_E$	$2[RPURP] - 2R(RRP)_E$
$2[(RRRRR)_E - \bar{R}R] - 2R(RRP)_E$	$2[(RRR\bar{R}RR)_E - \bar{R}R] - 2R(RRP)_E$
$2[(RP\bar{R}PR)_E - \bar{R}R] - 2R(RRP)_E$	$2[(PRR\bar{R}RP)_E - \bar{R}R] - 2R(RRP)_E$
$2[(PR\bar{R}RP)_E - \bar{R}R] - 2R(RRP)_E$	$2[(PPR\bar{R}PP)_E - \bar{R}R] - 2R(RRP)_E$
$2[(PP\bar{R}PP)_E - \bar{R}R] - 2R(RRP)_E$	$2[(RRURR)_E] - 2R(PRR)_E$
$2[5R - \bar{R}R] - 2R(PRR)_E$	$2[(PPRRP)_E - \bar{R}R] - 2R(PRR)_E$
$2[(PRRRR)_E - \bar{R}R] - 2R(PRR)_E$	$2[PRURP] - 2R(PRR)_E$
$2[(RRRRR)_E - \bar{R}R] - 2R(PRR)_E$	$2[RPURP] - 2R(PRR)_E$
$2[(RP\bar{R}PR)_E - \bar{R}R] - 2R(PRR)_E$	$2[(RRRRR)_E - \bar{R}R] - 2R(RR)_E$
$2[(PR\bar{R}RP)_E - \bar{R}R] - 2R(RR)_E$	$2[(PRRRR)_E - \bar{R}R] - 2R(RR)_E$
$2[(PP\bar{R}PP)_E - \bar{R}R] - 2R(RR)_E$	$2[(PPRRP)_E - \bar{R}R] - 2R(RR)_E$
$2[5R - \bar{R}R] - 2R(RR)_E$	$2[(RRURR)_E] - 2R(RR)_E$
$2[(PRRRR)_E - \bar{R}R] - 2R(RR)_E$	$2[(PPRRP)_E - \bar{R}R] - 2R(RR)_E$
$2[(RRRRR)_E - \bar{R}R] - 2R(RR)_E$	$2[RPURP] - 2R(RR)_E$
$2[(RP\bar{R}PR)_E - \bar{R}R] - 2R(RR)_E$	
$2[(PR\bar{R}RP)_E - \bar{R}R] - 2R(RR)_E$	
$2[(PP\bar{R}PP)_E - \bar{R}R] - 2R(RR)_E$	
$2[P\bar{R}U\bar{R}P] - 2P\bar{R}(RR)_E$	
$2[RPURP] - 2P\bar{R}(RR)_E$	

the moving platform F&C line graph are obtained as shown in Figure 20. It can be seen from Figure 20 that in the course of two translation and one rotation, the force constraint line vectors provided by 1, 2 branched

chains are parallel and located on the moving platform. The force constraints provided by each branch chain are perpendicular to the plane formed by the two couple

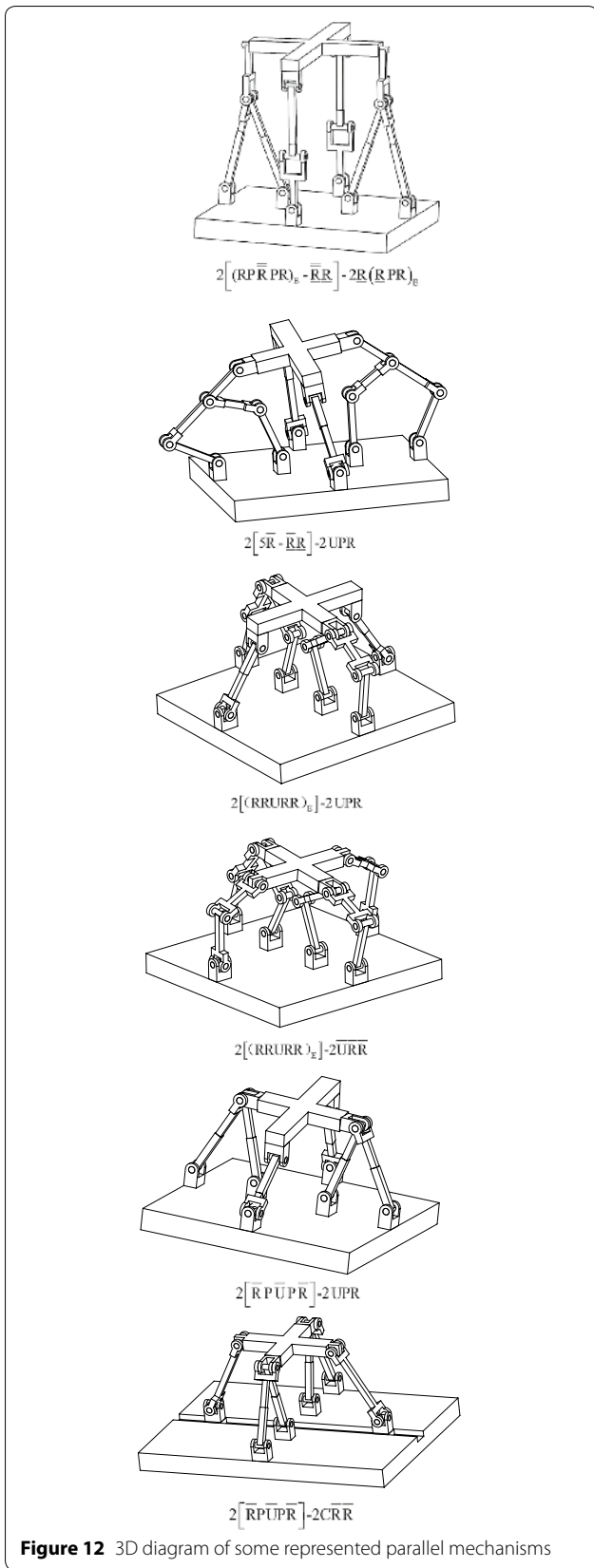

constraints provided by the branch chain. According to Grassmann line geometry theory, the rank of the constraint space is always 3.

It can be seen from Figure 20(d) that the mechanism has two DOFs of movement in the vertical plane and one DOF of rotation perpendicular to the vertical plane. So there is no instantaneity in motion process.

7 Conclusions

Type synthesis of 2R1T and 2T1R redundant actuated parallel mechanisms is completed in this paper. The conclusions are drawn as follows.

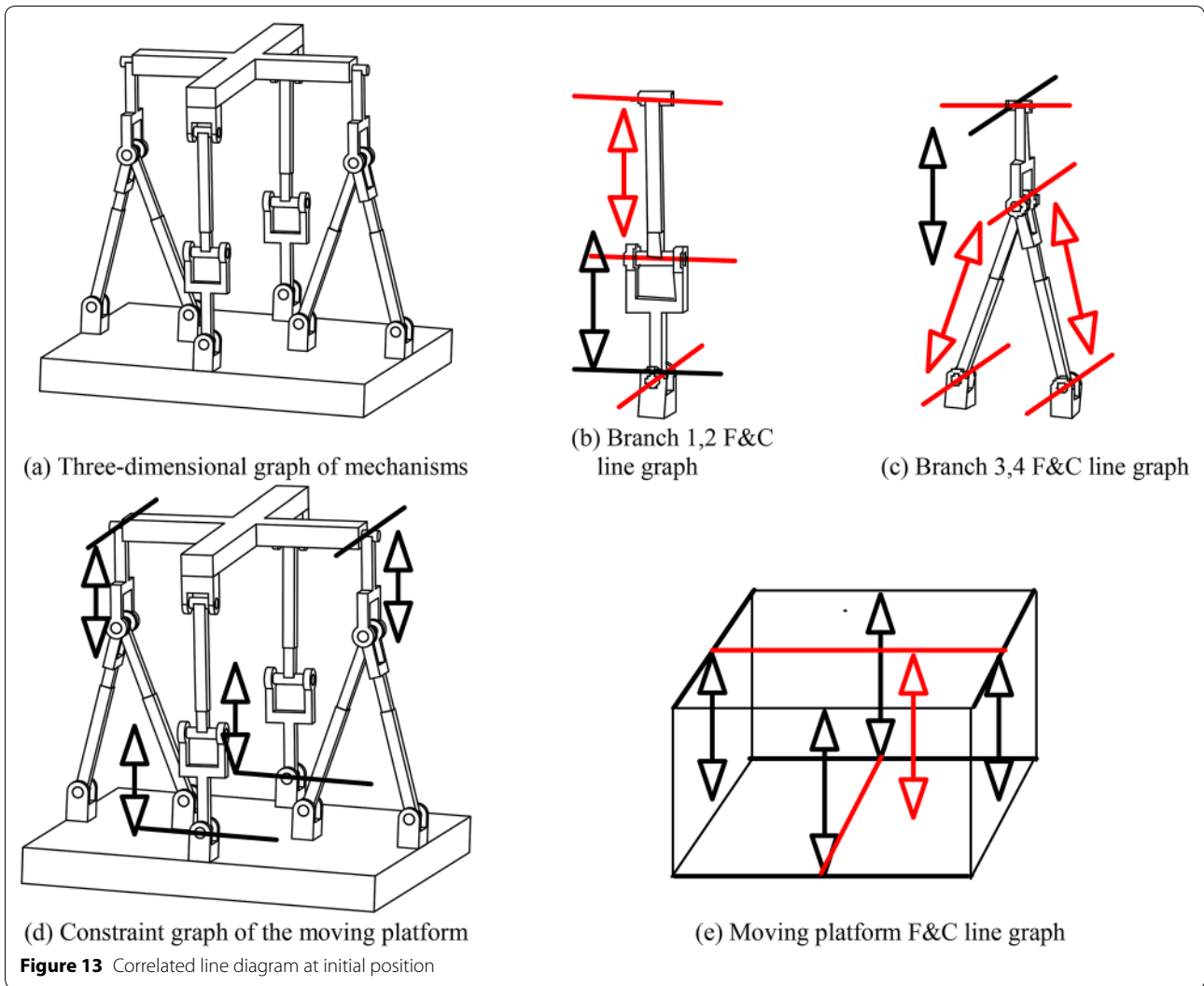

- (1) Based on Grassmann line geometry principle and graph theory, a systematic and effective synthesis method of redundant parallel mechanisms with closed-loop units is proposed. The method is simple, intuitive and has clear physical meaning. In this method, redundant branched chains are added from two aspects: redundant branches and closed-loop units. The redundancy in redundant branches and closed-loop units can be arbitrarily selected according to the performance of the focus. The redundant branches and redundant numbers in closed-loop units can be selected arbitrarily according to their specific performance. This method can obtain the diversity of mechanisms from many ways. It is also applicable to the type synthesis of 2, 4, 5, 6 DOF redundant parallel mechanisms.
- (2) Based on the Grassmann line geometry principle and Atlas method, this paper synthesizes the first and second type 2R1T parallel mechanisms with closed-loop redundant actuated and the second type 2T1R redundant parallel mechanisms with few branch chains and closed-loop unit redundant actuated. Each type of mechanism has 238, 92 and 15 new types respectively. The instantaneous analysis of the synthesized mechanism by the Atlas method shows that all the mechanisms are not instantaneous, which proves the feasibility and practicability of the synthesized method proposed in this paper.
- (3) The synthesized mechanisms in this paper contain both redundant branched chains and closed-loop units, and the mechanisms have good symmetry, actuated also has good symmetry, so the mecha-

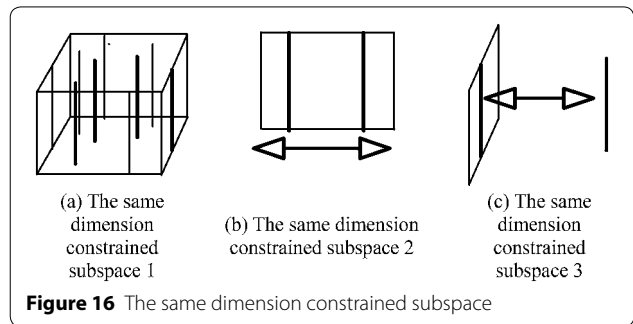
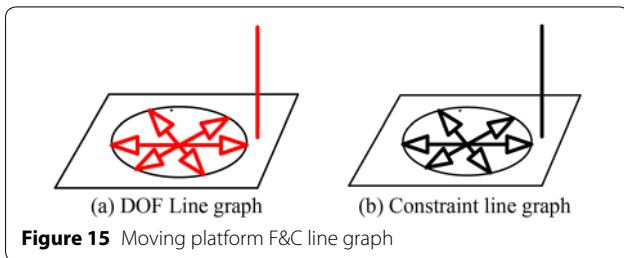
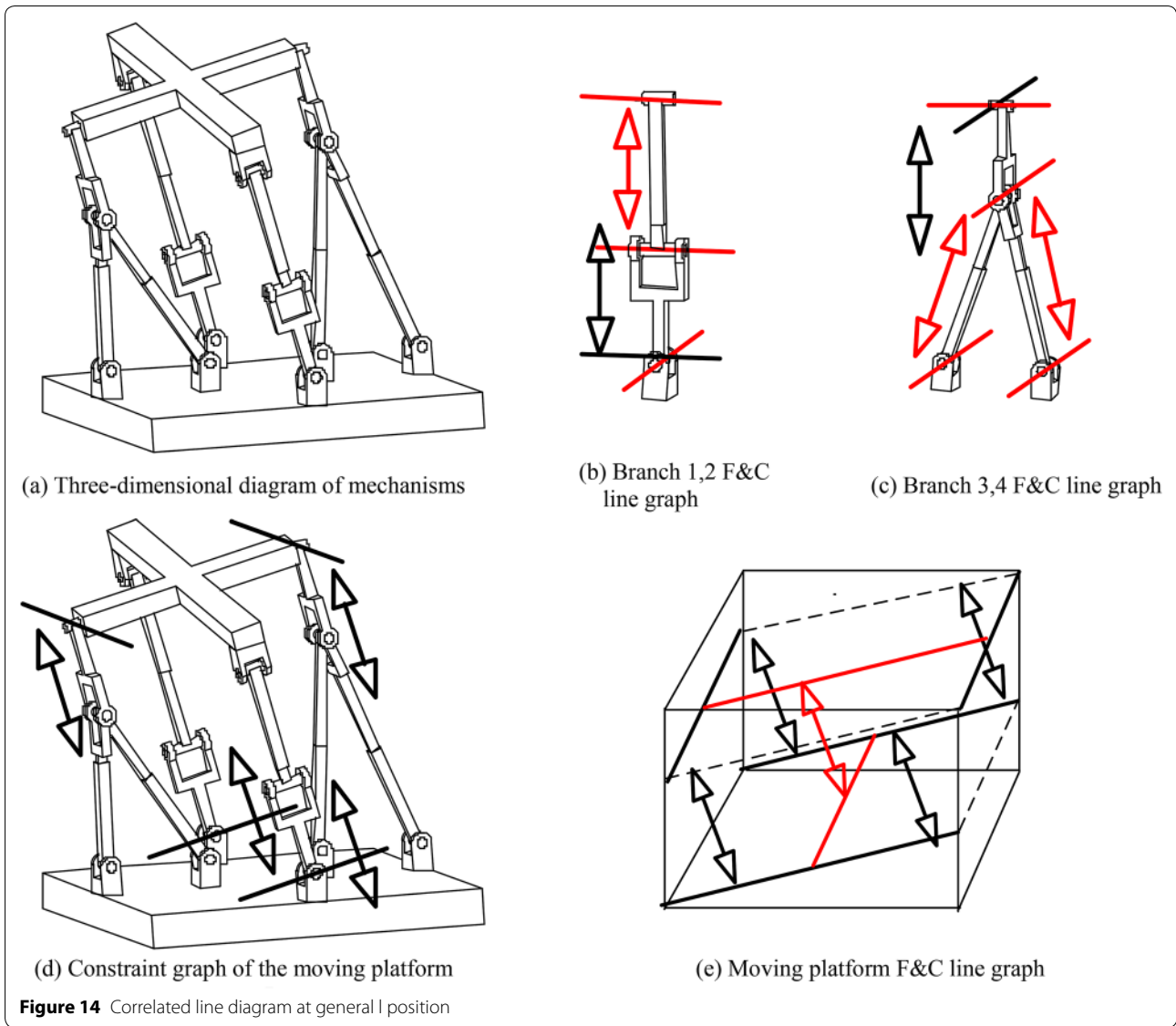

Table 7 Constraint allocation schemes

Constraint allocation schemes

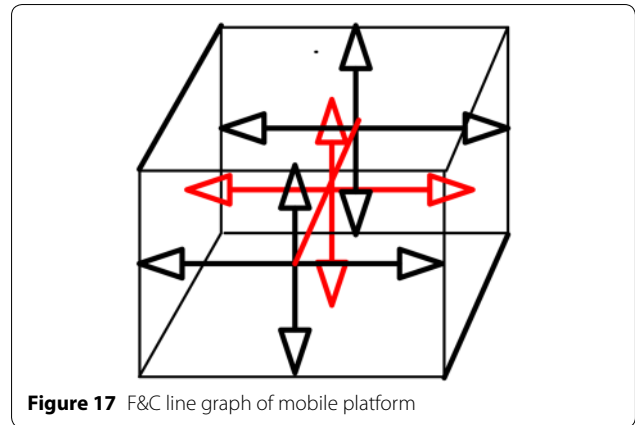
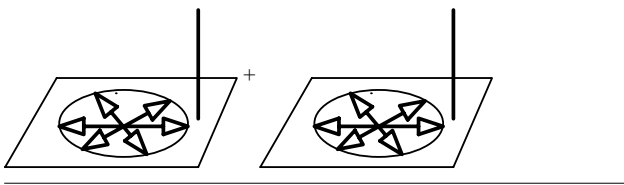

Figure 17 F&C line graph of mobile platform

Table 8 Type synthesis process

	Branch chain constraint line graph and dual DOF graph with couple	Redundant DOF graph	Corresponding branched chain structure
Chains 1			$(RR\bar{R}\bar{R}\bar{R})_E - \bar{P}$ $(RP\bar{R}\bar{P}\bar{R})_E - \bar{R}$ $(P\bar{R}\bar{R}\bar{R}\bar{P})_E - \bar{R}$ $(RR\bar{R}\bar{R}\bar{R})_E - \bar{R}$ $(RP\bar{R}\bar{R}\bar{P}\bar{R})_E - \bar{R}$ $(P\bar{R}\bar{R}\bar{R}\bar{P})_E - \bar{R}$ $5\bar{R} - \bar{R}$ $(P\bar{R}\bar{R}\bar{R}\bar{P})_E - \bar{R}$ $(RP\bar{R}\bar{P}\bar{R})_E - \bar{R}$ $(P\bar{R}\bar{R}\bar{R}\bar{R})_E - \bar{R}$ $(P\bar{R}\bar{P}\bar{R}\bar{P}\bar{R})_E - \bar{R}$ $(P\bar{R}\bar{R}\bar{R}\bar{R}\bar{R})_E - \bar{R}$ $(P\bar{R}\bar{P}\bar{R}\bar{R}\bar{P}\bar{R})_E - \bar{R}$ $P5\bar{R} - \bar{R}$ $(P\bar{R}\bar{P}\bar{R}\bar{P}\bar{R})_E - \bar{R}$
Chains 2			
Branch chain assembly requirements	The force constraints provided by the two branches need to be parallel in space The force constraints provided by each branch chain are perpendicular to the plane formed by the two couple constraints provided by the branch chain The rank of couple constraint is 2		

Table 9 Types of symmetric mechanisms

Some 2T1R parallel mechanism representatives

$2[(RP\bar{R}\bar{P}\bar{R})_E - \bar{R}]$	$2[(P\bar{R}\bar{R}\bar{R}\bar{R})_E - \bar{R}]$
$2[(P\bar{R}\bar{R}\bar{R}\bar{P})_E - \bar{R}]$	$2[(P\bar{R}\bar{P}\bar{R}\bar{P}\bar{R})_E - \bar{R}]$
$2[5\bar{R} - \bar{R}]$	$2[(RR\bar{R}\bar{R}\bar{R})_E - \bar{R}]$
$2[(P\bar{R}\bar{R}\bar{R}\bar{P})_E - \bar{R}]$	$2[(RP\bar{R}\bar{R}\bar{R}\bar{P}\bar{R})_E - \bar{R}]$
$2[(RP\bar{R}\bar{P}\bar{R})_E - \bar{R}]2[(P\bar{R}\bar{P}\bar{R}\bar{R}\bar{P}\bar{R})_E - \bar{R}]$	$2[(P\bar{R}\bar{R}\bar{R}\bar{R}\bar{R}\bar{P}\bar{R})_E - \bar{R}]$
$2[(RR\bar{R}\bar{R}\bar{R})_E - \bar{R}]$	$2[P5\bar{R} - \bar{R}]$
$2[(P\bar{R}\bar{R}\bar{R}\bar{R}\bar{R}\bar{R})_E - \bar{R}]$	$2[(P\bar{R}\bar{P}\bar{R}\bar{P}\bar{R})_E - \bar{R}]$

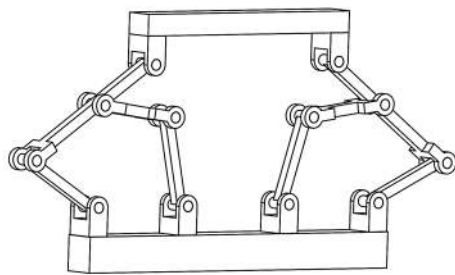

$$2[5\bar{R} - \bar{R}]$$

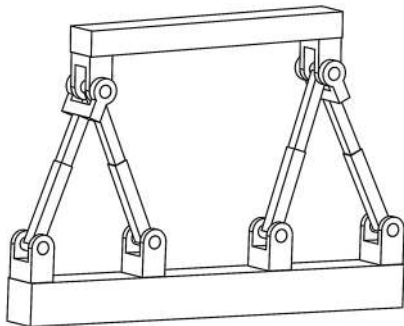

$$2[(R\bar{P}\bar{R}P)_E - \bar{R}]$$

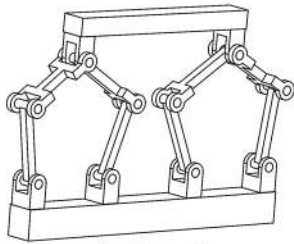

$$2[(RR\bar{R}RR)_E - \bar{R}]$$

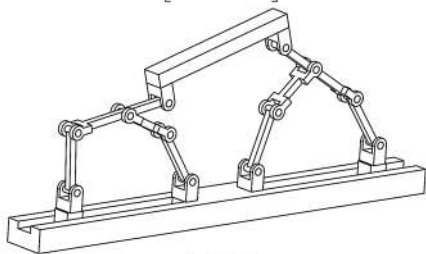

$$2[P5\bar{R} - \bar{R}]$$

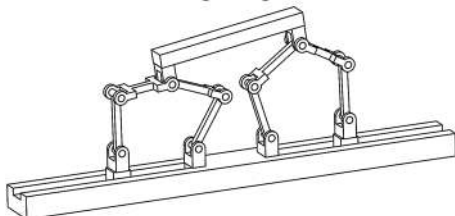

$$2[(PRR\bar{R}RR)_E - \bar{R}]$$

Figure 18 3D diagram of some represented parallel mechanisms

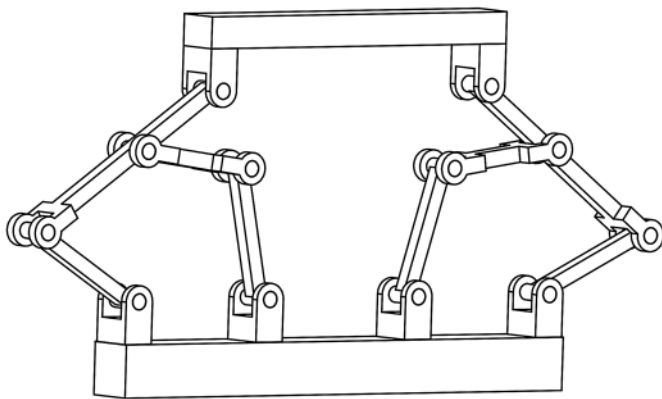

(a) Three-dimensional diagram of mechanisms

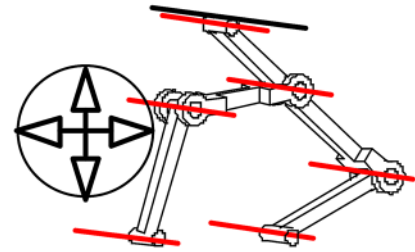

(b) Branch F&C line graph

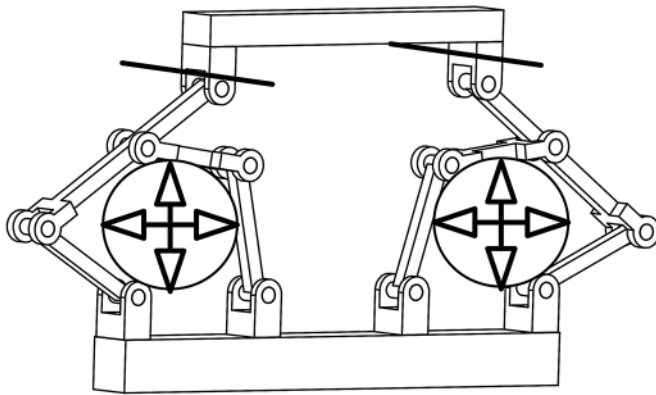

(c) Constraint graph of the moving platform

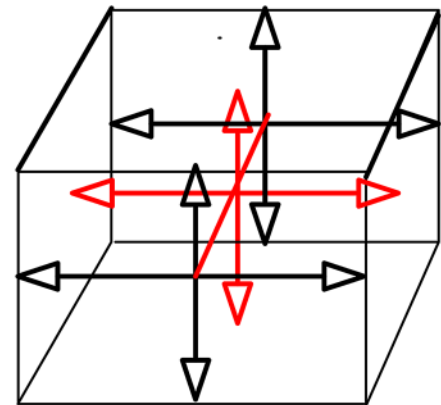

(d) Moving platform F&C line graph

Figure 19 Correlated line diagram at initial position

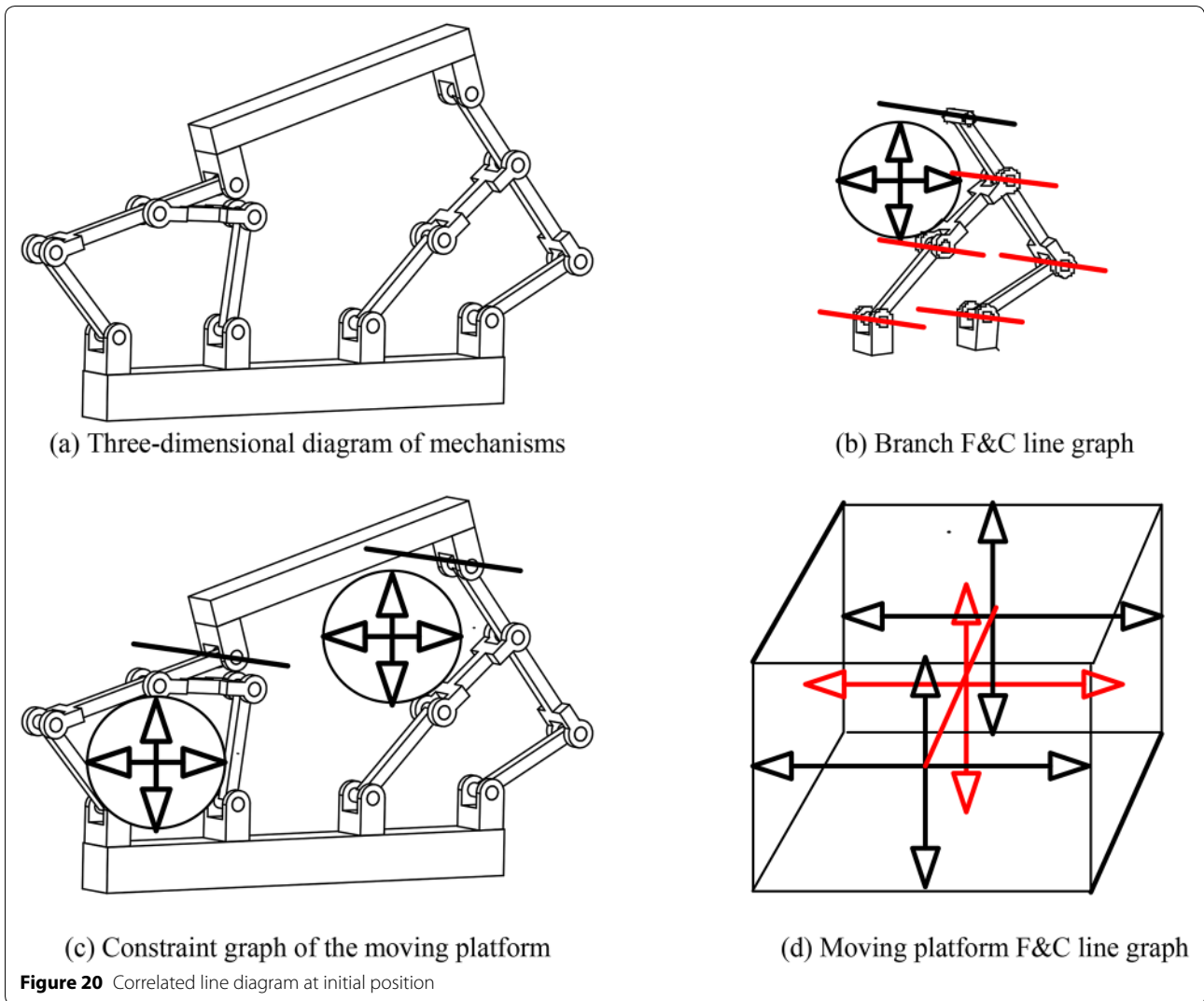

nism has good comprehensive performance. The synthesized mechanism has high redundancy actuated, so it has high stiffness and large bearing capacity.

Acknowledgements

The authors sincerely thanks to associate professor Tao Sun of *Tianjin University*, assistant researcher Fugui Xie and professor Hu Bo of *Yanshan University* for their critical discussion and reading during manuscript preparation.

Authors' contributions

YZ conceived the basic idea, and carried out research, analysis and writing of the manuscript. YL provided theoretical guidance. LZ contributed the revise of this paper. All authors read and approved the final manuscript.

Authors' Informations

Yongquan Li, born in 1979, is currently an associate professor at *Yanshan University, China*. His main research interests include parallel mechanism and robot technology.

Yang Zhang, born in 1994, is currently a PhD candidate at *State Key Laboratory of Robotics and System, Harbin Institute of Technology, China*. He received his master's degree from *Yanshan University, China*, in 2019. His research interests include type synthesis of parallel mechanism.

Lijie Zhang, born in 1969, is currently a professor at *Yanshan University, China*. His main research interests include parallel mechanism and robot technology, hydraulic system integration and control technology.

Funding

Supported by National Natural Science Foundation of China (Grant No. 51875499).

Competing Interests

The authors declare no competing financial interests.

Author Details

¹ Parallel Robot and Mechatronic System Laboratory of Hebei Province, *Yanshan University, Qinhuangdao 066004, China*. ² Key Laboratory of Advanced Forging & Stamping Technology and Science, Ministry of Education of China,

Yanshan University, Qinhuangdao 066004, China. ³ School of Mechanical Engineering and Automation, Harbin Institute of Technology, Shenzhen 518052, China. ⁴ Hebei Provincial Key Laboratory of Heavy Machinery Fluid Power Transmission and Control, Yanshan University, Qinhuangdao 066004, China.

Received: 7 January 2020 Revised: 16 June 2020 Accepted: 17 September 2020

Published online: 05 November 2020

References

- [1] K E Zanganeh, J Angeles. Instantaneous kinematics and design of a novel redundant parallel manipulator. *Proceedings of IEEE International Conference on Robotics and Automation*, 1994, 4: 3043-3048.
- [2] H W Kim, J H Lee, H Suh, et al. Comparative study and experimental verification of singular-free algorithms for a 6 DOF parallel haptic device. *Mechatronics*, 2005, 15(4): 403-422.
- [3] H T Liu, T Huang, A Kecskeméthy, et al. Force/motion transmissibility analyses of redundantly actuated and overconstrained parallel manipulators. *Mech. Mach. Theory*, 2017, 109: 126-138.
- [4] J Kim, J C Hwang, J S Kim, et al. Eclipse II: a new parallel mechanism enabling continuous 360-degree spinning plus three-axis translational motions. *Robotics & Automation IEEE Transactions on*, 2001, 17(4): 423-434.
- [5] B J Yi. Geometric analysis of antagonistic stiffness in redundantly actuated parallel mechanisms. *Journal of Robotic Systems*, 1993, 10(5): 581-603.
- [6] S H Lee, J H Lee, B J Yi, et al. Optimization and experimental verification for the antagonistic stiffness in redundantly actuated mechanisms: a five-bar example. *Mechatronics*, 2005, 15(2): 213-238.
- [7] M A Adli, H Hanafusa. Effect of internal forces on stiffness of closed mechanisms. *Journal of the Robotics Society of Japan*, 1992, 10(1): 845-850.
- [8] M A Adli, H Hanafusa. Contribution of internal forces to the dynamics of closed chain mechanisms. *Robotica*, 1995, 13(5): 507-514.
- [9] J Z Guo, D Wang, R Fan, et al. Stiffness characteristic distribution of redundant drive parallel mechanism of 3PRS/UPS. *Journal of Beijing University of Aeronautics and Astronautics*, 2014, 40(4): 500-506.
- [10] L Cheng, Y F Zhao, Y S Zhao. Motion control algorithm of a 5-DOF parallel machine tool. *Proceedings of IEEE International Conference on Robotics and Biomimetics, Sanya, China, Dec.15-18, 2007*: 2194-2199.
- [11] Y S Zhao, K J Zheng, Q C Li, et al. Kinematic analysis of 5-UPS / PRPU 5-DOF parallel machine tool. *Journal of Mechanical Engineering*, 2004, 40(2): 12-16. (in Chinese)
- [12] D Q Kong, J Wu, T M Li, et al. Control of a 4-DOF parallel kinematic machine with actuation redundancy. *Journal of Mechanical Engineering*, 2009, 45(9): 152-157. (in Chinese)
- [13] J Wu, J S Wang, L P Wang, et al. Dynamics and control of a planar 3-DOF parallel manipulator with actuated redundancy. *Mech. Mach. Theory*, 2009, 44(4): 835-849.
- [14] X G Han, W Y Chen. Study on the kinematics of a new redundant actuated PKMS. *7th International Conference on Progress of Machining Technology, China, Beijing, China, 2004*: 424-429.
- [15] G Gogu. T1R3-type redundantly-actuated parallel manipulators. Recent Progress in Robotics: Viable Robotic Service to Human, *Lecture Notes in Control and Information Sciences*, 2008, 370: 79-90.
- [16] G Gogu. Fully-isotropic redundantly-actuated parallel wrists with three degrees of freedom. *Proceedings of the ASME International Design Engineering Technical Conferences and Computers and Information in Engineering Conference*, 2007: 943-950.
- [17] H B Qu. *Type synthesis and parasitic motion avoidance of redundant actuated parallel mechanisms*. Beijing: Beijing Jiaotong University, 2013. (in Chinese)
- [18] H B Qu, Y H Liang, Y F Fang, et al. Statics and stiffness analysis of 4-RRS redundant spherical parallel mechanism. *Journal of Mechanical Engineering*, 2015, 51(11): 8-15. (in Chinese)
- [19] S H Li, H L Cui, Y M Liu. The synthesis of eliminating redundant driving branches of internal singular three-translational parallel mechanisms. *Journal of Mechanical Engineering*, 2014, 50(23): 36-41. (in Chinese)
- [20] F G Xie, X J Liu, T M Li. Type synthesis and typical application of 1T2R type parallel robotic mechanisms. *Mathematical Problems in Engineering*, 2013, 2013: 1-12.
- [21] F G Xie, X J Liu, Y Zheng, et al. Type synthesis of 2T1R-type parallel kinematic mechanisms and the application in manufacturing. *Robotics and Computer-Integrated Manufacturing*, 2014, 30(1): 1-10.
- [22] F G Xie, T M Li, X J Liu. Type synthesis of 4-DOF parallel kinematic mechanisms based on Grassmann line geometry and atlas method. *Chinese Journal of Mechanical Engineering*, 2013, 26(6): 1073-1081.
- [23] Y Q Li, Y Zhang, Y Guo, et al. New method for type synthesis of 2R1T redundant driven parallel mechanisms. *Journal of Mechanical Engineering*, 2019, 55(23): 25-37. (in Chinese)
- [24] Z Huang, Q C Li. Type synthesis of symmetrical lower-mobility parallel mechanisms using the constraint-synthesis method. *Int. J. Robot.*, 2003, 22(1): 59-79.
- [25] Y D Xu, D S Zhang, J T Yao, et al. Type synthesis of the 2R1T parallel mechanism with two continuous rotational axes and study on the principle of its motion decoupling. *Mech. Mach. Theory*, 2017, 108: 27-40.
- [26] M X Wang, T Huang. Type synthesis of 1T2R 3-DOF parallel mechanism. *Journal of Mechanical Engineering*, 2015, 51(17): 1-7.
- [27] Q C Li, J M Hervé. 1T2R parallel mechanisms without parasitic motion. *IEEE Trans. Rob.*, 2010, 26(3): 401-410.
- [28] T Sun, S F Yang, T Huang, et al. A way of relating instantaneous and finite screws based on the screw triangle product. *Mech. Mach. Theory*, 2017, 108: 75-82.
- [29] T Sun, X M Hu. Type synthesis of 1T2R parallel mechanisms with parasitic motions. *Mech. Mach. Theory*, 2018, 128: 412-428.
- [30] J Wei, J S Dai. Reconfiguration-aimed and manifold-operation based type synthesis of metamorphic parallel mechanisms with motion between 1R2T and 2R1T. *Mech. Mach. Theory*, 2019, 139: 66-80.
- [31] B Monsarrat, C M Gosselin. Singularity analysis of a three-leg six-degree-of-freedom parallel platform mechanism based on Grassmann line geometry. *Int. J. Robot Res.*, 2001, 20(4): 312-326.
- [32] S Z Li, J J Yu, G H Zong. Configuration synthesis and principal degree of freedom analysis of parallel flexible mechanisms based on screw theory. *Journal of Mechanical Engineering*, 2010, 46(13): 54-60. (in Chinese)
- [33] J J Yu, X Pei, G H Zong. *Graphical approach to creative design of mechanical devices*. Beijing: Beijing Science Press, 2014. (in Chinese)

Submit your manuscript to a SpringerOpen® journal and benefit from:

- Convenient online submission
- Rigorous peer review
- Open access: articles freely available online
- High visibility within the field
- Retaining the copyright to your article

Submit your next manuscript at ► [springeropen.com](https://www.springeropen.com)