

A New Method of Aircraft Motion Error Extraction From Radar Raw Data For Real Time Motion Compensation

JOAO R. MOREIRA

Abstract—Presented is a new solution for real-time motion compensation. The main idea is to extract all the necessary motions of the aircraft from the radar backscatter signal using a new radar configuration and new methods for evaluating the azimuth spectra of the radar signal. Hence an inertial navigation system becomes unnecessary for many applications. The motion compensation parameters for real-time motion error correction are the range delay, the range dependent phaseshift, and the pulse repetition frequency. The motions of the aircraft to be extracted are the displacement in line-of-sight (LOS) direction, the aircraft's yaw and drift angle, and the forward velocity. Results show that a three-look image with an azimuth resolution of 3 m in L-band using a small aircraft is achievable, and the implementation of this method in real time using an array processor is feasible.

I. INTRODUCTION

SYNTHETIC APERTURE RADARS (SAR) synthesize a long antenna by transmitting electromagnetic energy and coherently adding the successively reflected and received pulses to obtain high resolution in flight (azimuth) direction. The resolution in range direction is achieved either by transmitting very short pulses or by using pulse compression. To achieve a coherent integration, called azimuth compression, it is necessary that phase errors, resulting from spurious platform motion errors, are compensated. The platform motion error is defined as the error between the actual flight path and the nominal one. For SAR systems mounted on small aircrafts, motion errors are considerably high due to atmospheric turbulence and aircraft properties. After having determined the motion errors of the aircraft, motion compensation can be realized by adjusting the pulse repetition frequency (PRF), applying a range-dependent phaseshift to each received pulse and delaying it. By adjusting the PRF, one compensates for the aircraft forward-velocity variations, so that the emissions will occur at constantly spaced intervals. Adjusting the phase and range delay, one compensates for the displacement in line-of-sight (LOS) direction.

This paper will present a method to extract the displacement in LOS-direction, the aircraft velocity, and the yaw and drift angle from the radar raw data. The method is based on the analysis of the azimuth spectrum of the radar

raw data. The primary condition to implement this method is the use of a wide azimuth antenna beam. This is obtained using a short, fixed, mounted pencil-beam antenna rather than the usual long, stabilized antenna [1]. Thus both the complex gimbaling system and the clutterlock loop are avoided.

II. PROPERTIES OF THE AZIMUTH SPECTRUM

Consider the radar geometry of a strip-mapping SAR, where $V_v(t)$ is the aircraft's forward velocity, $V_b(t)$ is the velocity error in LOS-direction, t is the time, PRF is the pulse repetition frequency, ϑ is the angle between the cross-flight direction and a vector pointing to a point target on the ground, and R is the range of the target. The antenna points perpendicularly to the nominal flight path, illuminating a swath to one side of the aircraft. Due to $V_v(t)$ and $V_b(t)$, the radar pulse suffers a frequency or Doppler shift of

$$F_{\text{Doppler}}(t, \vartheta) = \frac{2 \cdot V_v(t) \cdot \sin \vartheta}{\lambda} + \frac{2 \cdot V_b(t) \cdot \cos \vartheta}{\lambda} \quad (1)$$

where λ is the wavelength of the transmitted pulse. For small ϑ , (1) can be simplified to

$$F_{\text{Doppler}}(t, \vartheta) \cong \frac{2 \cdot V_v(t) \cdot \vartheta}{\lambda} + \frac{2 \cdot V_b(t)}{\lambda} \quad (2)$$

Using the radar equation, the azimuth power spectrum $S(f)$ can be expressed as the product

$$S(f) = k_S \cdot G^4(f) \cdot B^2(f) \quad (3)$$

where f is the frequency, $G(f)$ is the one-way antenna gain in azimuth direction, $B(f)$ is the ground reflectivity, considered real, and k_S is a constant. $G^4(f)$, which represents the antenna pattern, can be shifted in frequency by an angle $\varphi(t)$, which is the sum of yaw and drift angle, and the velocity in LOS-direction $V_b(t)$ as follows:

$$f_a \cong \frac{2 \cdot V_v(t) \cdot \sin \varphi(t)}{\lambda} + \frac{2 \cdot V_b(t)}{\lambda} \quad (4)$$

where f_a is the frequency shift of $G^4(f)$, $\varphi(t) = \alpha(t) + \beta(t)$, $\alpha(t)$ is the yaw, and $\beta(t)$ is the drift angle of the aircraft. $B^2(f)$, which represents the ground reflectivity,

Manuscript received October 23, 1989; revised March 5, 1990.
The author is with DLR, German Aerospace Research Establishment, Institute for Radio Frequency Technology, 8031 Oberpfaffenhofen, FRG.
IEEE Log Number 9036084.

can be shifted in frequency by the velocity in LOS-direction $V_b(t)$ as follows:

$$f_r \cong \frac{2 \cdot V_b(t)}{\lambda} \quad (5)$$

where f_r is the frequency shift of $B^2(f)$.

The extraction of the motion errors of the aircraft is based on two methods. The first method analyzes only the ground reflectivity part of the azimuth power spectrum and is called reflectivity displacement method (RDM). The second method analyzes only the antenna pattern part of the azimuth power spectrum and is called spectrum centroid method (SCM).

III. THE REFLECTIVITY DISPLACEMENT METHOD (RDM)

The reflectivity displacement method analyzes the frequency shift between two ground reflectivity functions of adjacent and strong overlapping azimuth power spectra.

The azimuth power spectrum is obtained by Fourier-transforming the data in the azimuth dimension. The intensity of each frequency channel of an azimuth power spectrum varies according to an exponential probability function. To decrease this variance, one determines the azimuth power spectra of a group of successive range bins and averages them. The intensity variance of each frequency channel is decreased with the number of the spectra averaged, and the azimuth power spectrum is represented more accurately.

Let us assume that the azimuth power spectra have a data length of Δt and are calculated in time intervals also equal to Δt (there is no overlap of data in time domain). The frequency shift $V(t)$ between two ground reflectivity functions from two adjacent azimuth power spectra can be derived from (2) and (5) and expressed as

$$V(t) \cong -\frac{2 \cdot V_v^2(t) \cdot \Delta t}{\lambda \cdot R} + \frac{2 \cdot \dot{V}_b(t) \cdot \Delta t}{\lambda} \quad (6)$$

where R is the range of the center of the selected range bin group and Δt is the time interval between the two adjacent azimuth spectra. The maximum bandwidth of the frequency shift function $V(t)$ is dependent on Δt and is expressed, considering the sampling theorem, as

$$BW_V = \frac{1}{2 \cdot \Delta t} \quad (7)$$

To measure the frequency shift $V(t)$, it is considered that the ground reflectivity function $B(f)$ has a high contrast, defined by

$$K = \frac{\frac{1}{\text{PRF}} \cdot \int B^2(f) df}{\left[\frac{1}{\text{PRF}} \cdot \int B(f) df \right]^2} - 1. \quad (8)$$

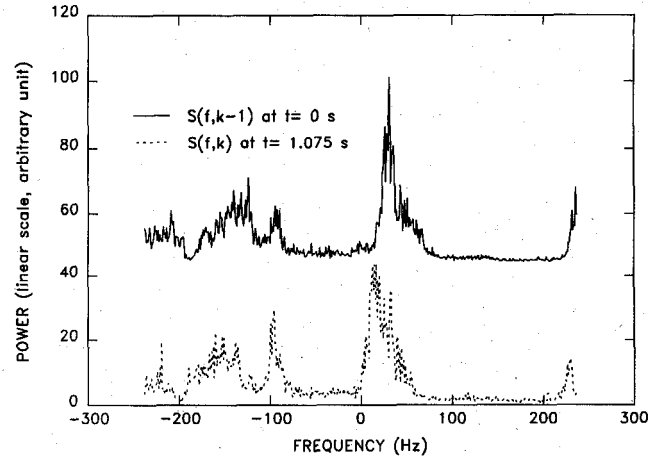

Fig. 1. Two adjacent azimuth power spectra taken with time interval $\Delta t = 1.075$ s.

As the antenna pattern function $G^4(f)$ shows only a slight variation across the considered azimuth bandwidth, it is replaced by a constant and (3) approximated to

$$S(f) \cong k'_S \cdot B^2(f) \quad (9)$$

where k'_S is a constant. Then the measurement of the frequency shift $V(t)$ of the ground reflectivity function $B(f)$ can be carried out by simply determining the position of the maximum of the cross-correlation between two adjacent azimuth power spectra. This way gives a very accurate measure of the frequency shift if Δt is much smaller than the illumination time of the antenna in azimuth direction. This assures that the two adjacent azimuth spectra are strongly correlated. Fig. 1 shows two adjacent azimuth power spectra obtained using the following parameters.

- Wavelength: 0.23 m (*L*-band).
- PRF: 476 Hz.
- Δt : 1.075 s.
- Data length of the azimuth power spectrum: 512 complex points (1.075 s).
- Antenna beamwidth (3 dB) in azimuth direction: 46° .
- Aircraft velocity: 50 m/s.
- Range of the raw data: 1920 m.
- Resulting antenna illumination time in azimuth direction: 30 s.
- Estimated frequency shift $V(t)$ considering (6) and $\dot{V}_b(t)$ equals zero: 12.2 Hz.

The azimuth power spectra at $t = 0$ s and $t = 1.075$ s in Fig. 1 are very similar with the exception of the negative frequency shift of the azimuth power spectra $S(f, k)$ at $t = 1.075$ s described by (6). Carrying out a cross-correlation between both spectra, one obtains a frequency shift of 12.1 Hz, as shown in Fig. 2.

As we get $V(t)$ by this correlation, the acceleration in LOS-direction $\dot{V}_b(t)$ must be separated from the forward velocity $V_v(t)$. This is done using a low- and a high-pass filter. The forward velocity has a very low bandwidth; for example, 0–0.05 Hz, assuming a turbulence with a stan-

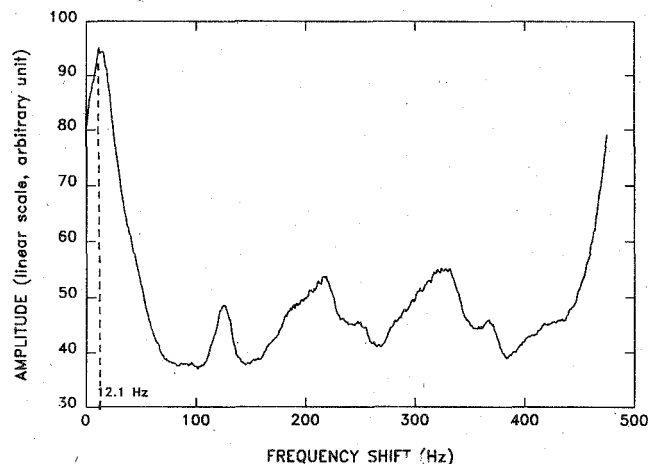

Fig. 2. Cross-correlation of azimuth power spectra $S(f, k-1)$ and $S(f, k)$ shown in Fig. 1. Frequency shift $V(k) = 12.1$ Hz is determined from position of maximum of cross-correlation.

standard deviation of about 1 m/s and a small aircraft such as the Dornier Do228 [2]. The acceleration in LOS-direction has a much higher bandwidth, where only the higher frequencies are important for motion compensation; for example, frequencies higher than 0.1 Hz. Considering the power spectral density (PSD) of the acceleration in LOS-direction and the PSD of the forward velocity of the Do228 aircraft, we get an overlap between the two terms of (6) of less than -15 dB, so that both the forward velocity and the acceleration in LOS-direction can be well separated from each other. The displacement in LOS-direction is obtained, integrating two times the acceleration in LOS-direction. Fig. 3 shows the block diagram of the reflectivity displacement method.

The accuracy of RDM depends on the contrast K of the reflectivity function $B(f)$, on the time interval Δt between two adjacent azimuth spectra, and on the number of RDM procedures N_{RDM} .

By imaging land surface that is not homogeneous, we get always a high-contrast K , which implies a high accuracy of the RD method. By imaging a homogeneous source, such as sea or desert, we get a low-contrast K , which implies reduced accuracy of the RD method. The degradation of the accuracy of the displacement in LOS-direction measurement with decrease of the contrast K is greater than the degradation of the accuracy of the forward velocity measurement.

The upper limit of the accuracy is determined by the time interval Δt and by the number of RDM procedures N_{RDM} . The time interval Δt defines two important parameters: the bandwidth BW_V and the quantization noise of $V(t)$.

The quantization noise of $V(t)$ occurs because the frequency of the azimuth power spectrum has a quantization defined by $1/\Delta t$. Fig. 1 shows an example where the frequency dimension is represented by steps of 0.93 Hz. The bandwidth BW_V becomes higher with the decrease of Δt , as (7) shows. The quantization noise of $V(t)$ becomes

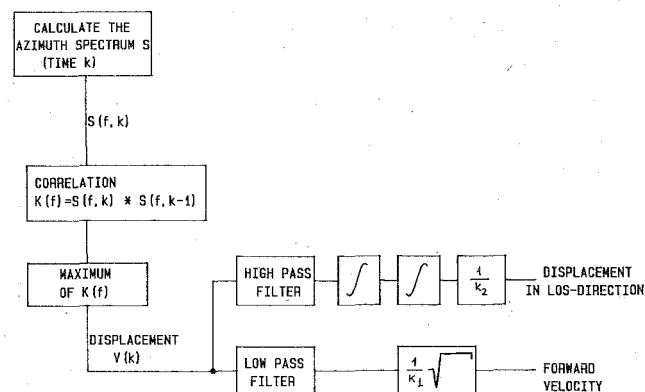

Fig. 3. Block diagram of reflectivity displacement method.

lower with the increase of Δt , as (6) shows. A compromise must be found for Δt so that both parameters BW_V and $V(t)$ are optimum.

The number of RDM procedures N_{RDM} means the number of RDM implementations carried out at different ranges at the same time. Hence one gets N_{RDM} independent frequency shift $V(t)$ values at each iteration. The accuracy of the displacement in LOS-direction can be improved up to $\sqrt{N_{\text{RDM}}}$ times by low-pass filtering it in range direction. The accuracy of the forward velocity can also be improved up to $\sqrt{N_{\text{RDM}}}$ times by averaging it in range direction.

The equation for the determination of the accuracy will be published [3], [4].

IV. THE SPECTRUM CENTROID METHOD

This method basically determines the Doppler centroid of the antenna pattern part $G^4(f)$ of the azimuth spectrum. As the beamwidth of the antenna in azimuth direction is very wide, the method using the azimuth frequency spectrum of the processed complex imagery [5] has a very low bandwidth, due to the illumination time of the antenna that is longer than 30 s in L-band.

As the illumination time of the antenna is long, the ground reflectivity can be determined very precisely using a Kalman filter, if the reflectivity does not change with time very much. Extracting the ground reflectivity part $B^2(f)$ from the azimuth spectrum, one can estimate the Doppler centroid of the antenna pattern part $G^4(f)$ with high accuracy and bandwidth. The Doppler centroid estimator method used was proposed by [5] and uses a weighting function proposed by [6] to obtain the highest possible accuracy.

The accuracy of the ground reflectivity prediction depends on its contrast K . If K is high, the ground reflectivity varies strongly with the time due to bright targets that always have a variable and unpredictable reflectivity. If K is low, the ground reflectivity can easily be determined.

The Doppler centroid of the antenna pattern $G^4(f)$ is shifted by $\varphi(t)$ and $V_b(t)$ according to the (4). $\varphi(t)$ is a combination of the yaw $\alpha(t)$ and the drift angle $\beta(t)$ of the aircraft. Yaw motion is caused by turbulence and air-

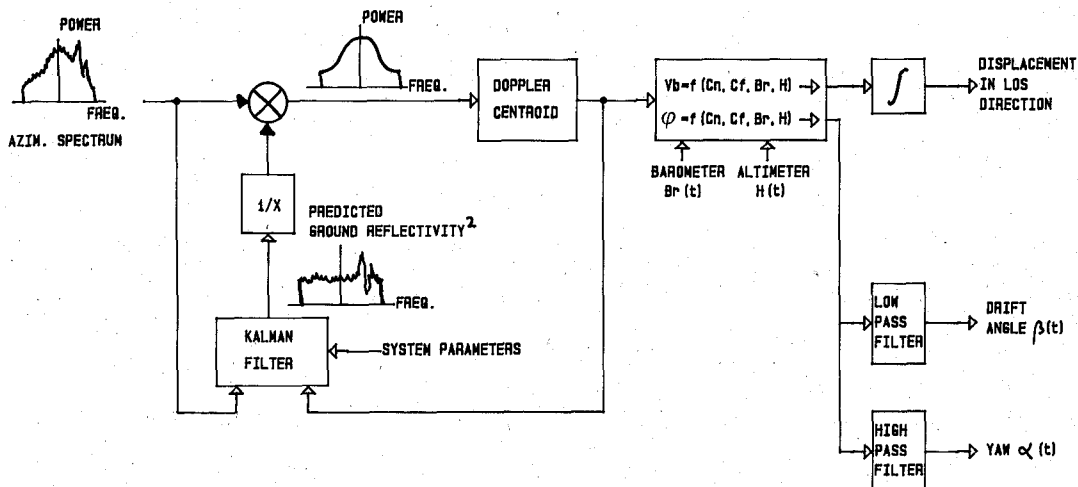

Fig. 4. Block diagram of spectrum centroid method. Calculated azimuth power spectrum $S(f)$ is divided by predicted ground reflectivity $B^2(f)$ to determine antenna pattern part $G^2(f)$ corresponding to (3). Velocity in LOS-direction V_b can be evaluated as function of Doppler centroid in near range C_n and far range C_f and of barometric altitude given by high-precision barometer $B_r(t)$ supported by radar altimeter $H(t)$. Displacement in LOS-direction is determined integrating V_b . To calculate angle $\varphi(t)$, which is sum of drift angle $\beta(t)$ and yaw $\alpha(t)$ of aircraft, one takes same variables as for calculation of V_b . Drift and yaw angle can be well separated from each other using high- and low-pass filter.

craft instability, and the drift angle is caused by wind. The yaw motion has a high bandwidth, and the drift angle has a very low bandwidth, so that $\varphi(t)$ has almost the same bandwidth as the velocity in LOS-direction. Thus they must be separated, considering the geometry of the aircraft. The displacement in LOS-direction and the yaw and drift angles are calculated by estimating the Doppler centroid of the calculated antenna pattern in near ($C_n(t)$) and far ($C_f(t)$) range and by evaluating the data of a high-precision barometer ($B_r(t)$) supported by a radar altimeter ($H(t)$). The yaw motion is separated from the drift angle via a high- and a low-pass filter. Fig. 4 shows the block diagram of the spectrum centroid method (SCM).

Finally, the SCM works with high accuracy when the contrast K of the ground reflectivity is low. When the contrast K increases, the degradation of both the accuracy of the displacement in LOS-direction measurement and the determination of the yaw angle is greater than the degradation of the accuracy of the drift angle measurement.

V. COMBINATION OF THE MOTION EXTRACTION METHODS

The combination of the two methods is implemented to increase the accuracy of the displacement in LOS-direction. Thus the accuracy of the displacement in LOS-direction will be almost independent of the contrast K of the ground reflectivity function. This is implemented by giving different weightings to both methods according to K .

VI. RESULTS

This motion compensation system has been successfully implemented off-line with the raw data of the experimental SAR system of DLR, E-SAR [7], [8]. Presently a motion compensation processor is implemented off-line and carries out only the RDM. The SCM has been tested

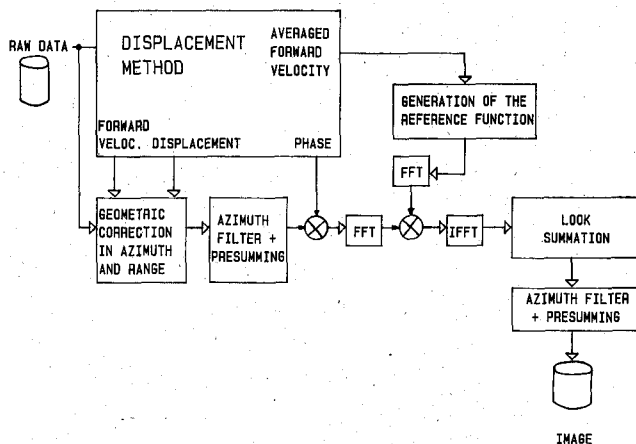

Fig. 5. Block diagram of off-line motion compensation processor.

successfully with simulated raw data and is under development to process E-SAR raw data. Fig. 5 shows the block diagram of the off-line motion compensation processor. The RDM extracts the displacement in LOS-direction and the forward velocity from the raw data according to Fig. 3.

With the extracted displacement in LOS-direction and the forward velocity, one can geometrically correct the raw data in azimuth and range directions. This geometric correction consists of a two-dimensional resampling of the raw data using linear interpolation. After this, the raw data are filtered, presummed, and then phase-corrected in azimuth direction. The phase in LOS-direction is obtained multiplying the displacement in LOS-direction by $4\pi/\lambda$.

Now, one can consider that the aircraft flew a straight line and had a forward velocity equal to the mean value of the extracted forward velocity. Hence a common multilook SAR processor in the frequency domain is used to obtain the motion-compensated imagery.

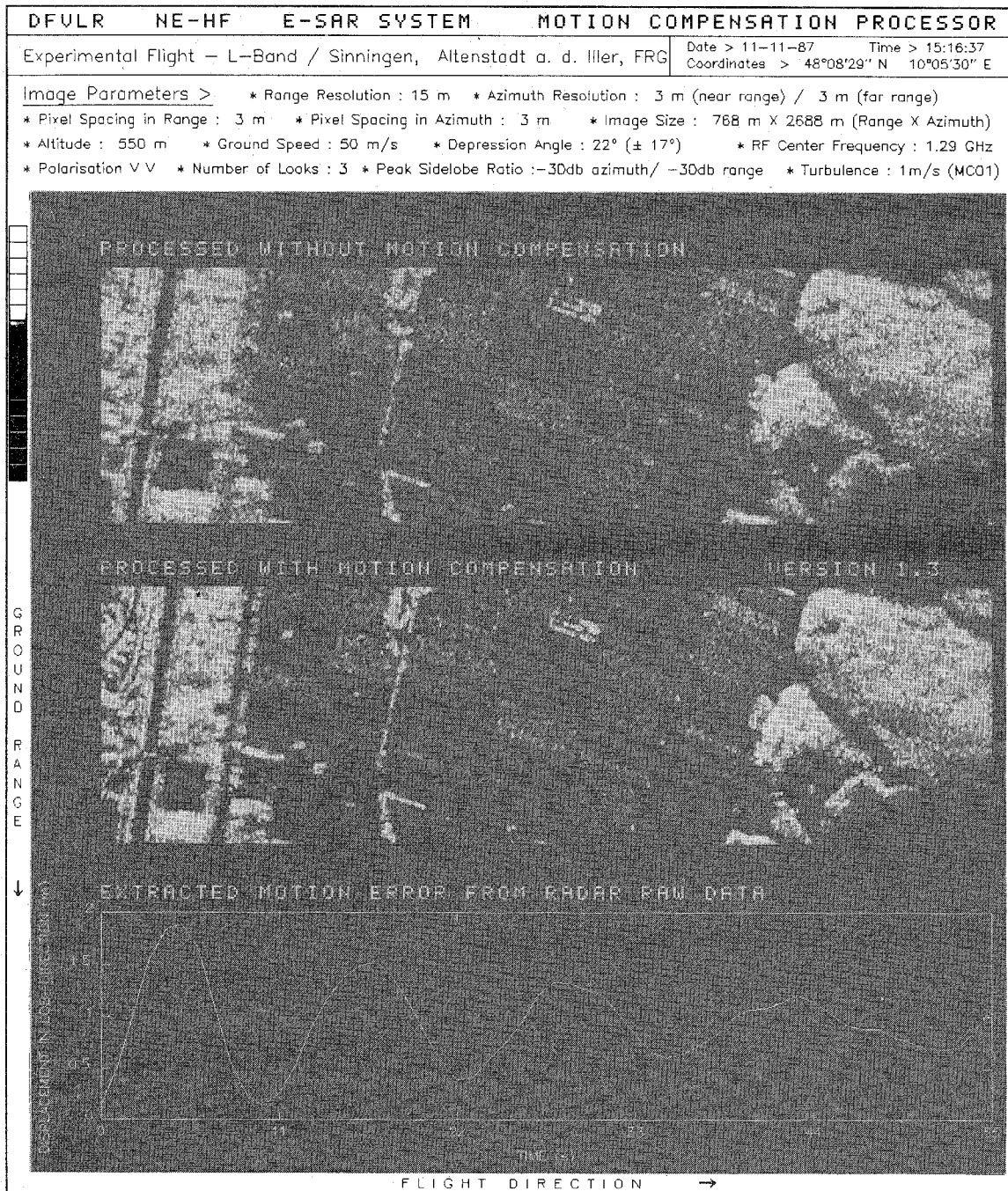

Fig. 6. Example of motion compensation with RD method.

Fig. 6 shows an example of motion compensation where the displacement in LOS-direction in near range is represented at the bottom. The main parameters for motion compensation were

- illumination time > 30 s,
- implementation only of the RD method,
- time interval Δt : 0.5 s,
- azimuth power spectrum length: 256 points,
- number of range bins for the averaged azimuth spectrum for each RDM-procedure: 32,
- number of RDM-procedures used: 20,
- bandwidth in LOS-direction \cong 0.1 up to 1 Hz,

- bandwidth of forward velocity \cong 0 up to 0.05 Hz,
- estimated residual error of displacement in LOS: 8 mm (1σ),
- estimated residual error of forward velocity: 0.1 m/s (1σ).

The flight time of the pass was about 55 s. The time-scale is shown in the displacement in LOS-direction diagram. It corresponds very accurately to the position of the aircraft in the figure.

During the first 10 s, the aircraft passed through a strong turbulence. This caused the city area and the Iller river and canal to be heavily distorted. In the following sec-

onds, the automatic pilot of the aircraft tried to compensate for that bump. The corresponding oscillations are shown in the displacement in LOS-direction diagram of Fig. 6. The period of about 10 s matches fairly well the response of the control system of the automatic pilot.

Both images were processed with three looks. In the aforementioned image, the misplacement of the looks due to aircraft motions can be observed. Especially in the time interval between 33 and 38 s, where there is a line of pylons.

The estimated residual error of the displacement in LOS-direction was obtained by analyzing the responses of 20 targets chosen in Fig. 6, including the pylons. The estimated residual error of the forward velocity was calculated considering the geometric distortions of the image.

The equation for the determination of the residual errors and the comparison with pulse responses of calibrated corner reflectors is reported in [3], [4].

Recently obtained results show that the accuracy of the RDM at higher frequencies of C-band is much better. C-band images with 2-m resolution and eight looks in azimuth have been obtained with motion error correction.

VII. IMPLEMENTATION IN REAL TIME

Considering the parameters used in the image shown in Fig. 6, one can calculate the number of FFT's per second necessary to carry out the RD method. Other operations, such as the correlation of adjacent power spectra, the low- and high-pass filter, the integrators, and other small operations, need much less computation time than the FFT's.

The number of FFT's per second N_{FFT} to calculate all the azimuth power spectra is given by

$$N_{\text{FFT}} = N_{\text{AVER}} \cdot \frac{1}{\Delta t} \cdot N_{\text{RDM}} \quad (10)$$

where N_{AVER} is the number of range bins used by one RDM procedure to build the averaged azimuth power spectrum. Hence we get 1280 FFT's per second, with a length of 256 points. This implies that the array processor used must calculate each FFT in about 0.78 ms, which corresponds to a computation power of about 40 Mflops.

VIII. CONCLUSION

This paper describes the principles of two extraction methods: The reflectivity displacement method (RDM) and the spectrum centroid method (SCM). Both methods can be implemented only in SAR sensors using a wide-beam antenna in azimuth.

The RDM, which was designed to be implemented over land, extracts the motion errors of the aircraft from the radar raw data, avoiding the need to azimuth compress the data first, as with other extraction methods. The RDM is also not sensitive to drift or yaw angle variations. As the E-SAR has a 46° wide antenna in azimuth, drift angles of

5° neither affect the performance of the RDM nor degrade the radiometric accuracy of the processed image.

The motion error in LOS can be divided into two regions of frequency, defined as high- and low-frequency errors. The low-frequency errors cause the point target response to be misplaced and defocused. High-frequency errors displace energy from the main lobe of the point target response into the sidelobe region, degrading the integrated sidelobe ratio (ISLR). Considering the integration time T of the synthetic aperture, the frequency limit between the two regions is given by $1/T$ [9], [10].

For the example given, the integration time of the azimuth compression for one look in far range (2600 m) is 2 s, the aircraft velocity being 50 m/s, the wavelength 0.23 m, and the resolution 3 m. Hence the frequency limit is equal to 0.5 Hz. As the bandwidth of the extracted motion error in LOS is limited to between 0.1 and 1 Hz, the RDM reduces both high- and low-frequency motion errors.

The bandwidth for the correction of low-frequency motion errors being 0.1 to 0.5 Hz allows not only the correction of linear and quadratic phase errors but also cubic and high-order phase errors. The correction bandwidth of high-frequency motion errors being 0.5 to 1 Hz allows a reduction of the sidelobe levels.

Also, the forward velocity can be extracted with a bandwidth between 0 and 0.05 Hz, adequate for most velocity variations of the aircraft under typical operating conditions [2].

Comparing the RDM with inertial navigation systems (INS), shown, for example, by [9] and [10], one can see that the INS has much higher bandwidth and accuracy but employs a complicated and expensive hardware and software. Considering the INS system shown by [9], for example, one gets a bandwidth of about 5 Hz with a residual error of the displacement in LOS of 0.33 mm.

The RDM can be an alternative to the well-known autofocus methods. The autofocus method has the advantage of imposing no severe restrictions on the configuration of the SAR sensor, unlike the RDM.

The RDM can be compared to perhaps the most comprehensive motion extraction method using autofocus, suggested by [11]. This autofocus method can extract the low-frequency motion errors in LOS of the aircraft. For the extraction, the raw data must first be azimuth-processed to allow the analysis of the contrast or the look displacement of the image. This requires a higher computation power than for the RDM and is difficult to carry out in real time. The bandwidth of the extraction is low due to the fact that the reference function used for the azimuth compression represents a low-pass filter for the extraction of high-frequency phase errors. Phase errors that contribute to the degradation of the ISLR cannot be extracted, for example. High-frequency phase errors can be extracted using other methods, however, such as the tuned autocompensator from [12].

As mentioned in [11], the autofocus method requires that the SAR system operates with a constant spatial PRF.

The RDM method works well with forward velocity variations and extracts these with a bandwidth of about 0.05 Hz.

Finally, the RDM can be implemented on SAR sensors in small aircrafts, offering good performance and a low-cost solution.

The SCM is a modification of the existing Doppler centroid method [5] for SAR with a wide-beam antenna in azimuth. Using Kalman filter techniques, the SCM allows a higher bandwidth for the estimation of the Doppler shift without serious degradation of accuracy.

ACKNOWLEDGMENT

The author wishes to thank C. Dahme, Dr. K. Gruener, R. Horn, Dr. W. Keydel, A. Moreira, R. Schmid, U. Spies, M. Werner, and F. Witte of DLR; Dr. C. Boesswetter, T. Pike, and A. Wolframm of MBB-Ottobrunn; Prof. J. Detlefsen of the Technical University of Munich; and Dr. T. Freeman of JPL, whose suggestions and contributions made this work possible.

REFERENCES

- [1] C. Boesswetter and A. Wolframm, "The design of an experimental synthetic aperture radar (SAR) for small aircrafts," presented at 13th Europ. Microwave Conf. (Workshop), Nürnberg, West Germany, Sept. 5-8, 1983.
- [2] H. Boehret, "Berechnung der Leistungsspektraldichten verschiedener Flugzustandsgrößen infolge stochastischer Böen," Dornier Aktenvermerk BM40-52/85, Friedrichshafen, West Germany, 1985.
- [3] J. R. Moreira, "Estimating the residual error of the reflectivity displacement method for aircraft motion error extraction from SAR raw data," in *Proc. IEEE Intern. Radar Conf.* (Arlington, VA), May 7-10, 1990, pp. 70-75.
- [4] J. R. Moreira, "Bewegungsextraktionsverfahren fuer SAR auf Kleinflugzeug," to be published.
- [5] F. K. Li, D. N. Held, J. Curlander, and C. Wu, "Doppler parameter estimation for spaceborne synthetic aperture radars," *IEEE Trans. Geosci. Remote Sensing*, vol. GE-23, pp. 47-56, 1985.
- [6] M. Y. Jin, "Optimal Doppler centroid estimation for SAR data from a quasi-homogeneous source," *IEEE Trans. Geosci. Remote Sensing*, vol. GE-24, pp. 1022-1025, 1986.
- [7] R. Horn, "E-SAR—The experimental airborne L/C-band SAR system of DFVLR," in *Proc. IGARSS '88 Symp.* (Edinburgh, UK), 1988, vol. 2, pp. 1025-1026.
- [8] R. Horn, "C-band SAR results obtained by an experimental airborne SAR sensor," in *Proc. IGARSS '89 Symp.* (Vancouver, BC, Can.), 1989, vol. 4, pp. 2213-2216.
- [9] G. Haslam and B. Reid, "Motion sensing requirements for synthetic aperture radar," *1983 IEEEC Proc.* (Toronto, ON, Can.), 1983, vol. 1, pp. 126-131.
- [10] J. Kirk, "Motion compensation for synthetic aperture radar," *IEEE Trans. Aerospace Electron. Syst.*, vol. AES-11, no. 3, pp. 338-348, 1975.
- [11] D. Blacknell, A. Freeman, S. Quegan, I. Ward, I. Fimley, C. Oliver, R. White, and J. Wood, "Geometric accuracy in airborne SAR images," *IEEE Trans. Aerospace Electron. Syst.*, vol. AES-25, no. 2, pp. 241-258, 1989.
- [12] Y. Chan, "A tuned auto-compensator for residual antenna motion in synthetic aperture radar systems," *IEEE Trans. Geosci. Remote Sensing*, vol. GE-24, pp. 1025-1027, Nov. 1986.

*



Joao R. Moreira was born in Rio de Janeiro, Brazil, in 1960. He received the Eng. degree in electrical engineering from the Aeronautical Technological Institute ITA, Sao Jose dos Campos, in 1982, and the Dipl.-Ing. degree, also in electrical engineering, from the Technical University of Munich, West Germany, in 1985. He is currently working towards the Dr.-Ing. degree at the Technical University of Munich.

In 1983 he joined the Institute for Radio Frequency Technology at the German Aerospace Research Establishment, DLR, in Oberpfaffenhofen, West Germany. Since 1983 he has been engaged in the design and development of the experimental SAR system "E-SAR" of DLR. Currently, he is responsible for the development of the real-time motion compensation system and the off-line motion compensation processor.