

2003-01-01

A new modified Smith predictor design

Pauline Sourdille

Technological University Dublin

Aidan O'Dwyer

Technological University Dublin, aidan.odwyer@tudublin.ie

Follow this and additional works at: <https://arrow.tudublin.ie/engscheleart>



Part of the [Controls and Control Theory Commons](#)

Recommended Citation

Sourdille, Pauline and O'dwyer, Aidan : A new modified Smith predictor design. Proceedings of the International Symposium on Information and Communication Technologies (ISICT 2003), Trinity College, Dublin, September, 2003. doi:10.21427/cxky-4x96

This Conference Paper is brought to you for free and open access by the School of Electrical and Electronic Engineering at ARROW@TU Dublin. It has been accepted for inclusion in Conference papers by an authorized administrator of ARROW@TU Dublin. For more information, please contact arrow.admin@tudublin.ie, aisling.coyne@tudublin.ie.



This work is licensed under a [Creative Commons Attribution-NonCommercial-Share Alike 4.0 License](#)

A New Modified Smith Predictor Design

Pauline Sourdille^ϕ and Aidan O'Dwyer^{*}

^ϕ*Department of Control Systems
Dublin Institute of Technology, Kevin Street
Dublin 8
IRELAND
E-mail: pauline.sourdille@dit.ie*

^{*}*Department of Control Systems
Dublin Institute of Technology, Kevin Street
Dublin 8
IRELAND
E-mail: aidan.odwyer@dit.ie*

Abstract – **A new modified Smith predictor structure is presented with its associated tuning rules.**

Keywords – **Smith predictor, Dead-time compensator**

I. INTRODUCTION

In the 1950's, O.J. Smith [1] developed the Smith predictor structure to compensate systems with time delay, which are a feature of many industrial processes. The Smith predictor structure utilises a mathematical model of the process in a minor feedback loop. One of its advantages is that the Smith predictor approach for compensating a Single Input Single output (SISO) process may be directly extended to the compensation of a Multiple Input Multiple Output (MIMO) process with the same delay in each path.

Since the Smith Predictor structure was proposed, many modifications have been proposed to improve the servo response, the regulator response or both. Modifications were accomplished to adapt the structure to stable, integrative or unstable systems. Sourdille and O'Dwyer [2] present an extensive review of the literature concerning modifications to the Smith predictor; this review was used to develop a generalised form of the predictor. This paper discusses the generalised form of the Smith predictor and a new modified Smith predictor structure with its associated tuning rules.

II. GENERALISED FORM OF SMITH PREDICTOR STRUCTURE

The general form of the Smith predictor is obtained by combining several structures ([1], [3-16]), which have common points, in one general structure. A number of structures were considered but not included into the general structure due to their complexity ([17-24]). Figure 1 shows the generalised form of the Smith predictor structure developed and equations (1) and (2) represent the servo and regulator responses, respectively.

$$\frac{y_p}{r} = \frac{[1+(G_{c3}+G_{c4})G_m e^{-s\tau_m}]G_{c1}G_{c5}G_{c6}G_p e^{-s\tau_p}}{1+G_m G_{c1}+G_{c4}G_m e^{-s\tau_m}+G_{c3}G_p e^{-s\tau_p}+(G_{c3}+G_{c4})G_m G_{c1}G_p e^{-s\tau_p}+G_{c1}G_{c6}G_{c2}(G_p e^{-s\tau_p}-G_m e^{-s\tau_m})} \quad (1)$$

$$\frac{y_p}{L} = \frac{(1+G_{c1}G_m+G_{c4}G_m e^{-s\tau_m}-G_{c1}G_{c2}G_{c6}G_m e^{-s\tau_m})G_p e^{-s\tau_p}}{1+G_m G_{c1}+G_{c4}G_m e^{-s\tau_m}+G_{c3}G_p e^{-s\tau_p}+(G_{c3}+G_{c4})G_m G_{c1}G_p e^{-s\tau_p}+G_{c1}G_{c6}G_{c2}(G_p e^{-s\tau_p}-G_m e^{-s\tau_m})} \quad (2)$$

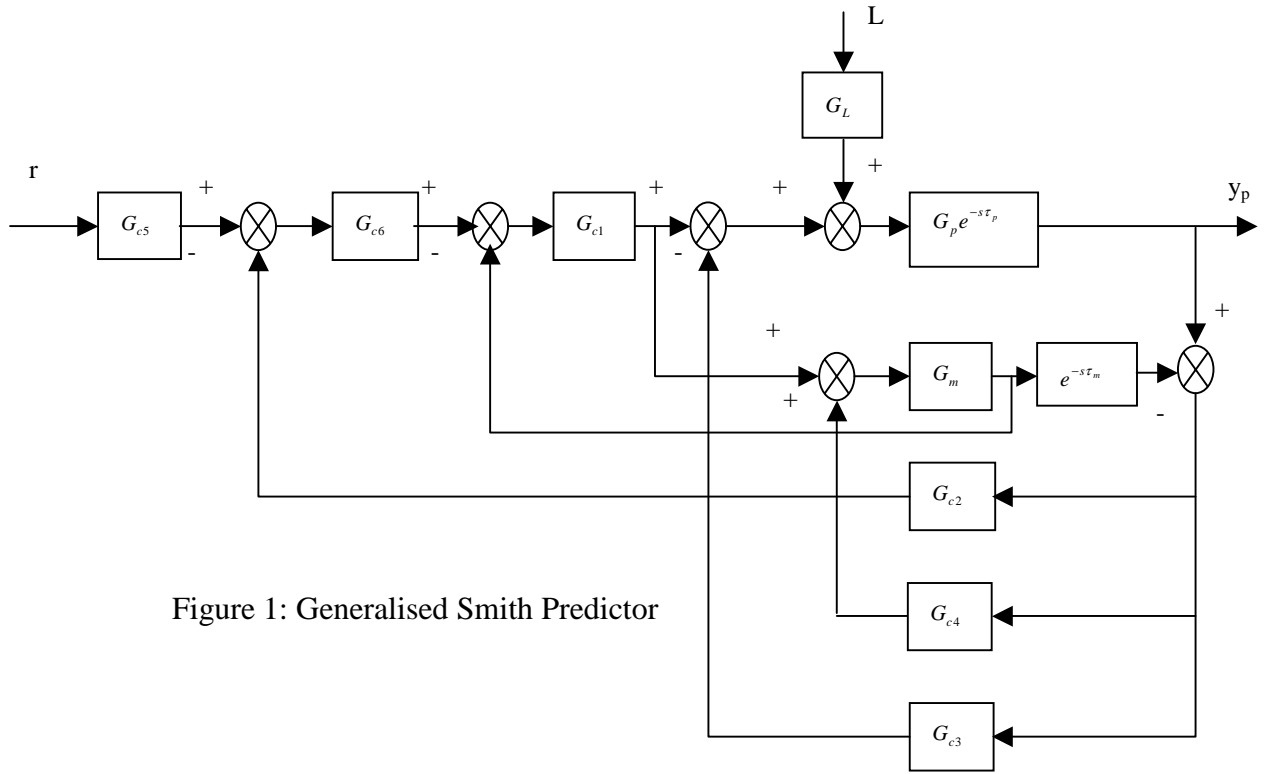

Figure 1: Generalised Smith Predictor

The requirements specified to design G_{c1} to G_{c6} are the obtaining of perfect servo and regulator responses (i.e. $\frac{y_p}{r} = 1$ and $\frac{y_p}{L} = 0$), and that the controller transfer functions are only expressed in terms of the model parameters. It turns out that three primary controllers need to be specified: one to optimise the servo response, one to optimise the regulator response and one to eliminate the mismatch between the process and the model. In the different cases, G_{c1} , G_{c5} and G_{c6} are equal to 1, and G_{c2} , G_{c4} and G_{c3} are equal to 0 when they are not used. After calculating each possible triplet of primary controllers, only fifteen cases are realisable, as some possibilities do not achieve the requirements specified above. From these realisable cases, only three cases are considered, as their controller transfer functions are of the simplest form to limit any necessary approximations. In the next section, one of these cases is explained in detail.

III. MODIFIED SMITH PREDICTOR STRUCTURE - CASE STUDIED

The servo and regulator responses are expressed by equations (3) and (4), respectively. As can be noticed from equations (3) and (4), G_{c3} will optimise the servo response, G_{c4} will optimise the regulator response and G_{c2} will eliminate the mismatch between the process and the process model.

$$\frac{y_p}{r} = \frac{[1+(G_{c3}+G_{c4})G_m e^{-s\tau_m}]G_p e^{-s\tau_p}}{1+G_m+G_{c4}G_m e^{-s\tau_m}+G_{c3}G_p e^{-s\tau_p}+(G_{c3}+G_{c4})G_m G_p e^{-s\tau_p}+G_{c2}(G_p e^{-s\tau_p}-G_m e^{-s\tau_m})} \quad (3)$$

$$\frac{y_p}{L} = \frac{[1+G_m+G_{c4}G_m e^{-s\tau_m} - G_{c2}G_m e^{-s\tau_m}]G_p e^{-s\tau_p}}{1+G_m+G_{c4}G_m e^{-s\tau_m} + G_{c3}G_p e^{-s\tau_p} + (G_{c3}+G_{c4})G_m G_p e^{-s\tau_p} + G_{c2}(G_p e^{-s\tau_p} - G_m e^{-s\tau_m})} \quad (4)$$

The following expressions may be calculated for G_{c2} , G_{c3} and G_{c4} by designing for perfect servo and regulator responses.

$$G_{c2} = 0 \quad (5), \quad G_{c3} = \frac{1}{e^{-s\tau_m}} \quad (6), \quad G_{c4} = -\frac{1+G_m}{G_m e^{-s\tau_m}} \quad (7)$$

Using the form of equation (8) for the non-delayed model, equation (7) becomes equation (9):

$$G_m = \frac{K_m}{T_m s + 1} \quad (8)$$

$$G_{c4} = -\frac{T_m s + 1 + K_m}{K_m e^{-s\tau_m}} \quad (9)$$

The controllers G_{c3} and G_{c4} are impossible to implement with real components, so approximations are needed. The inverse of the delay (equations (6) and (9) cannot be implemented), so the approximation detailed by Sourdille and O'Dwyer [2] is used:

$$\frac{1}{e^{-s\tau_m}} = \frac{1+B(s)}{1+B(s)e^{-s\tau_m}} \quad (10) \quad \text{with} \quad B(s) = \frac{T_m s + 1}{T_m s + p} \quad (11)$$

Expressions (12) and (13) are the realisable controller forms of equations (6) and (9):

$$G_{c3} = \frac{B(s)+1}{1+B(s)e^{-s\tau_m}} \quad (12) \quad \text{and} \quad G_{c4} = -\frac{T_m s + 1 + K_m}{K_m (T_m s + K_1)} * \frac{1+B(s)}{1+B(s)e^{-s\tau_m}} \quad (13)$$

IV. SIMULATION

To use the Smith predictor structure, a primary controller must be designed to achieve perfect responses (i.e. $\frac{y_p}{r} = 1$ and $\frac{y_p}{L} = 0$). This gives a primary controller of the following form (equation (14)) and its implementable approximation is given by equation (15).

$$G_c = -\frac{T_m s + 1}{K_m (1 - e^{-s\tau_m})} \quad (14) \quad \text{and} \quad G_c = \frac{T_m s + 1}{K_m (s + 1)(1 - e^{-s\tau_m})} \quad (15)$$

For the modified Smith predictor, equations (12) and (13) are used. Using these equations, an offset is observed for the servo response and the regulator response. The value of this offset may be evaluated by calculating the steady state of the servo and regulator responses. These calculations give a common offset for the responses, which is given by equation (16):

$$\text{Offset} = \frac{K_p}{K_p + 1} \quad (16), \quad K_p = \text{process gain}$$

To solve this problem, a Proportional controller, K_c , is introduced at the command signal to eliminate the offset for the servo response and a filter is included in series with the controller G_{c3} to eliminate the offset for the regulator response. As it is undesirable to express K_c in term of the process gain, K_p (as the process gain is, in

general, unknown), the approximation $K_p = K_m$ is used to determine K_c , with K_c being the inverse of the offset.

The expressions for the controllers in the modified Smith predictor (equations (12) and (13)) become equations (17) and (18), respectively.

$$G_{c3} = \frac{T_m s + 1}{\alpha K_m T_2 s} * \frac{1 + B(s)}{1 + B(s)e^{-s\tau_m}} \quad (17) \quad \text{and} \quad G_{c4} = \frac{T_m s + 1 + K_m}{K_m(T_1 s + K_1)} * \frac{1 + B(s)}{1 + B(s)e^{-s\tau_m}} \quad (18)$$

Table 1 presents tuning rules developed for each controller and the range of possible values for α and p depending on the index $\frac{\tau_m}{T_m}$.

	K_c	G_{c3}	G_{c4}	α	p
$0 < \frac{\tau_m}{T_m} \leq 0.5$	$\frac{K_m + 1}{K_m}$	$T_2 = \frac{T_m}{K_m}$	$T_1 = 50T_m, K_1 = 100$	$0.6 \leq \alpha \leq 1$	$3 \leq p \leq 5$
$0.5 < \frac{\tau_m}{T_m} < 1$	$\frac{K_m + 1}{K_m}$	$T_2 = T_m$	$T_1 = 50T_m, K_1 = 100$	$1 \leq \alpha \leq 1.5$	$2 \leq p \leq 3$
$1 < \frac{\tau_m}{T_m} \leq 2$	$\frac{K_m + 1}{K_m}$	$T_2 = \frac{5T_m}{K_m}$	$T_1 = 50T_m, K_1 = 100$	$0.6 \leq \alpha \leq 1.3$	$2 \leq p \leq 3$

Table 1: Tuning rules and the range of values for α and p

From these tuning parameter values, it can be concluded that α may be taken between 0.5 and 1.5 and p may be chosen between 2 and 5.

The following table (Table 2) shows the number of simulations, in which improvement in response was detected, when the modified Smith predictor was used instead of the Smith predictor, with the responses evaluated using the four indices (Integral Absolute Error-IAE, Integral Squared Error-ISE, Integral Time multiplied by Squared Error-ITSE and Integral of Squared Time multiplied by Squared Error-ISTSE). Three simulations are conducted on each of seven benchmark processes and models, giving 21 simulation results altogether.

	IAE	ISE	ITSE	ISTSE
Servo responses	18	14	17	15
Regulator responses	21	21	19	18
Corresponding Percentage	93%	83%	85%	79%

Table 2: Improvement in responses noted when the modified Smith predictor is used

From this table, it can be noticed that the modified Smith predictor structure gives improved performance compared to the use of the Smith predictor structure, especially for the regulator response. This is significant, as it is recognised that the Smith predictor structure facilitates relatively poor regulator response. One representative simulation result is shown in Figure 2. For this simulation,

$G_m e^{-s\tau_m} = \frac{2}{1+0.7s} e^{-1.4s}$, $G_p e^{-s\tau_p} = \frac{2}{1+0.7s} e^{-1.4s}$, $\alpha=1.1$ and $p=3$. In this simulation, the mismatch term is zero.

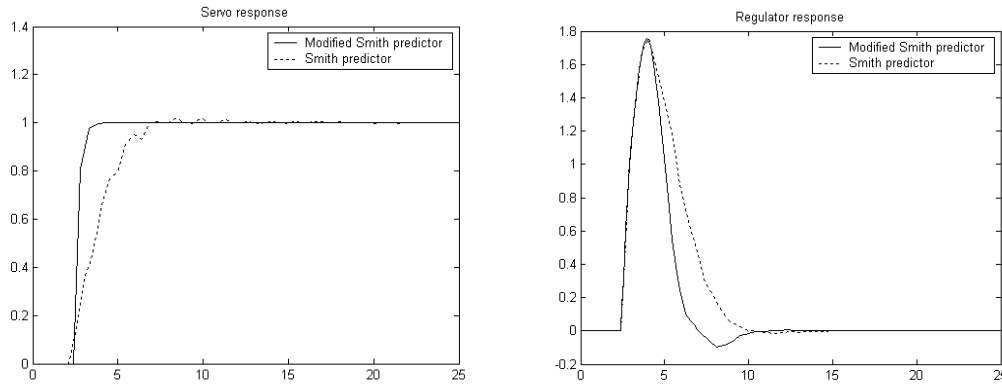

Figure 2: Responses for the modified Smith predictor and the Smith predictor

It is clear that the modified Smith predictor gives better servo and regulator responses.

V. CONCLUSION

A generalised Smith predictor structure is developed from several modified Smith predictor structures. A new modified Smith predictor structure with its associated tuning rules is subsequently presented. Our full panorama of simulation results show that better servo and regulator responses are not guaranteed with the modified Smith predictor compared with the responses achieved with a Smith predictor. However, the modified Smith predictor facilitates better overall responses, especially in regulator mode, for a significant majority of cases explored.

References

- [1] Smith, O.J.M. (1957). Closer control of loops with dead time, *Chemical Engineering Progress*, **53**, 217-219.
- [2] Sourdille, P. and O'Dwyer, A. (2003). An outline and further development of Smith predictor based methods for the compensation of processes with time delay. *Accepted by Irish Signals and Systems Conference 2003*.
- [3] Hang, C.C. and Wong, F.S. (1979). Modified Smith predictors for the control of processes with dead time, *Proceedings of the ISA Conference and Exhibition. Advances in Instrumentation and Control*, 34, 2, 33-44, Chicago, IL., U.S.A.
- [4] Watanabe, K., Ishiyama, Y. and Ito, M. (1983). Modified Smith predictor control for multivariable systems with delays and unmeasurable step disturbances, *International Journal of Control*, **73**, 959-973.
- [5] Romagnoli, J.A., Karim, M.N., Agamennoni, O.E. and Desages, A. (1985). Controller designs for model-plant parameter mismatch, *Proceedings of the ISA/85 International Conference and Exhibition. Advances in Instrumentation*, Philadelphia, Penn., U.S.A., **40**, 1, 441-452.

-
- [6] Romagnoli, J.A., Karim, M.N., Agamennoni, O.E. and Desages, A. (1988). Controller designs for model-plant parameter mismatch, *IEE Proceedings, Part D*, **135**, 157-164.
- [7] Palmor, Z.J. and Blau, M. (1994). An auto-tuner for Smith dead time compensator, *International Journal of Control*, **60**, 117-135.
- [9] Huang, H.-P., Chen, C.-L., Chao, Y.-C. and Chen P.-L. (1990). A modified Smith predictor with an approximate inverse of dead time, *AIChE Journal*, **36**, 1025-1031.
- [9] Dastych, J. (1995). Analysis and design of control loops with dead-times, *EURACO Workshop: 'Recent results in robust and adaptive control'*, 420-439, Florence, Italy.
- [10] Tian, Y.-C. and Gao, F. (1998b). Double-controller scheme for separating load rejection from set-point tracking, *Transactions of the Institute of Chemical Engineers*, **76**, Part A, 445-450.
- [11] Tian, Y.-C. and Gao, F. (1998c). Double-controller scheme for control of processes with dominant delay, *IEE Proceedings - Control Theory and Applications*, **145**, 5, 479-484.
- [12] Tian, Y.-C. and Gao, F. (1999). Injection velocity control of thermoplastic injection moulding via a double controller scheme, *Industrial Engineering Chemistry Research*, **38**, 9, 3396-3406.
- [13] Normey-Rico, J.E. and Camacho, E.F. (2002). A Unified Approach to Design Dead-Time Compensators for Stable and Integrative Processes with Dead Time, *IEEE Transactions on Automatic Control*, **47**, 2, 299-305.
- [14] Mitchell, R.J. (1990). Multi-microprocessor control of processes with pure time delay, *Transactions of the Institute of Measurement and Control*, **12**, 58-64.
- [15] Zhang, W.D. and Sun, Y.X. (1996). Modified Smith predictor for controlling integrator/time delay processes, *Industrial Engineering Chemistry Research*, **35**, 2769-2772.
- [16] Leonard, F. (1998). Tuning of a modified Smith predictor, *Proceedings of the IFAC Conference: System Structure and Control*, Nantes, France, 571-574.
- [17] Vrecko, D., Vrancic, D., Juricic, D. and Strmcnik, S. (2001). A new modified Smith predictor: the concept, design and tuning, *ISA Transactions*, **40**, 111-121.
- [18] Vrancic, D., Badillo, S.O.A. and Strmcnik, S. (1998a). Flexible Smith predictor controller, *Proceedings of the 7th Electrotechnical and Computer Science Conference*, Portoroz, Slovenia, Part A, 287-290.
- [19] Vrancic, D., Vrecko, D., Juricic, D. and Strmcnik, S. (1999a). Automatic tuning of the flexible Smith predictor controller, *Proceedings of the American Control Conference*, Preprints, Session FM14.
- [20] Majhi, S. and Atherton, D.P. (1999b). Modified Smith predictor and controller for processes with time delay, *IEE Proceedings - Control Theory and Applications*, **146**, 5, 359-366.
- [21] Kantor, J.C. and Andres, R.P. (1980). The analysis and design of Smith predictors using singular Nyquist arrays, *International Journal of Control*, **31**, 655-664
- [22] Matausek, M.R. and Micic, A.D. (1996). A modified Smith predictor for controlling a process with an integrator and long dead-time, *IEEE Transactions on Automatic Control*, **41**, 1199.
- [23] Matausek, M.R. and Micic, A.D. (1999). On the modified Smith predictor for controlling a process with an integrator and long dead-time, *IEEE Transactions on Automatic Control*, **44**, 8, 1603-1606.
- [24] Tian, Y.-C. and Gao, F. (1999b). Control of integrator processes with dominant time delay, *Industrial Engineering Chemistry Research*, **38**, 8, 2979-2983.