

## **A NOVEL COMPACT ARCHIMEDEAN SPIRAL ANTENNA WITH GAP-LOADING**

**Q. Liu, C.-L. Ruan, L. Peng, and W.-X. Wu**

Institute of Applied Physics  
University of Electronic Science and Technology of China  
Chengdu, 610054, China

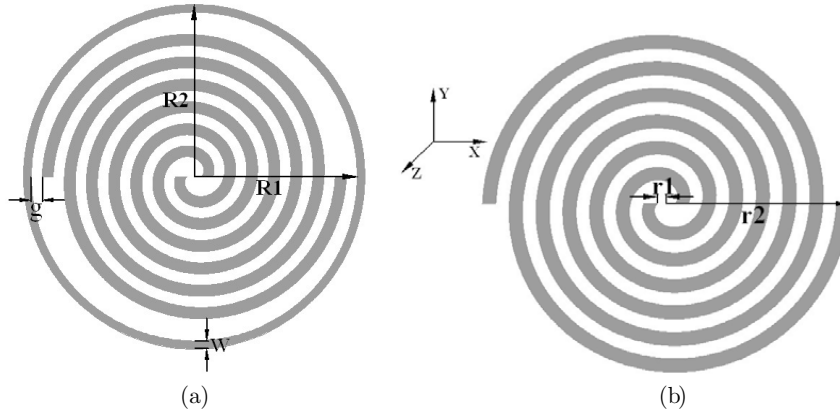
**Abstract**—A novel compact Archimedean spiral antenna with gap-loading is investigated in this paper. A circular frame sharing the same centre with the spiral elements introduces a capacitive gap. By adjusting the width of the gap and the width of the circular frame, the initial resonant frequency of the proposed antenna is shifted from 2.79 to 1.93 GHz. Compared with the traditional Archimedean spiral antenna with the same lowest operation frequency, the area of the proposed antenna can be reduced by more than 30%. Simulated radiation pattern results.

### **1. INTRODUCTION**

The rapid progress in personal and computer communication technologies demands the integration of more than one communication systems into a single compact module. This indicates that the future communication terminal antennas must meet the requirements of multi-band or wideband to sufficiently cover the possible operating bands [1–3]. The spiral antenna is a kind of ultra wideband antenna, which is originated from the 1950s' theory of frequency independent antenna, and has been used extensively since its introduction by Turner [4]. It possesses the advantages of the easy fabrication, the low-cost, the conformability, and the superior radiation efficiency. So it plays an important role in many fields, such as the only airborne antenna in use for military applications that require ultra wide bandwidth [5], the mobile systems, and the broadband satellite communication services.

Because the diameter of the spiral antenna is determined by the wave length of the lowest operation frequency, the size of the antenna is too large to meet the practice size demand when the low working frequency is required. In recent years, a lot of works have been done to

reduce the antenna size [6–13], however, most of them have not been extended to spiral antenna [14]. So it is very meaningful to seek ways to minimize the size of the spiral antenna with simple structure and low cost.



**Figure 1.** Geometry of the Archimedean spiral antenna with gap-loading and the traditional Archimedean spiral antenna.

In this paper, a novel compact Archimedean spiral antenna with gap-loading whose geometry shown in Fig. 1(a) is investigated. Here, the technical method of gap-loading [15, 16] is used to lower the initial resonant frequency. Compared with the traditional Archimedean spiral antenna working at the same lowest working frequency, the area of the proposed antenna can be reduced by more than 30%, meanwhile the gain remains almost the same.

## 2. ANTENNA DESIGN

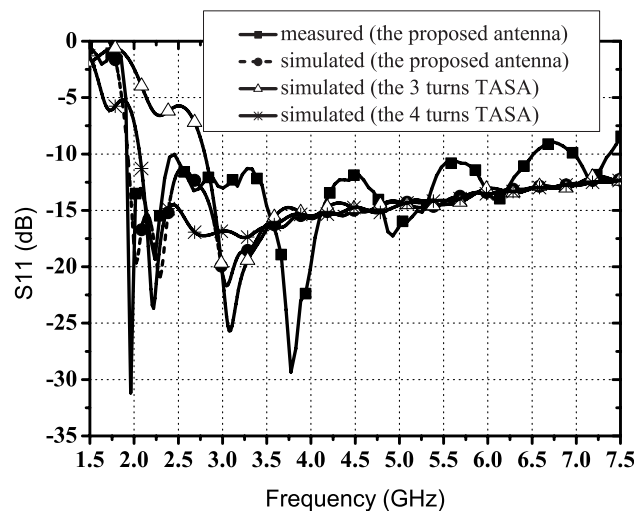
In this paper, two types of spiral antennas are studied for comparison. One is the Archimedean spiral antenna with gap-loading, and the other is the traditional Archimedean spiral antenna (TASA) with different turns. The antennas are fabricated on a substrate with a dielectric constant of 2.2 and thickness of 0.5 mm. The schematic configuration of the traditional spiral antenna is shown in Fig. 1(b). The spiral arms are spaced at a distance of 1.5 mm, a distance equal to that of the arm width to produce a self-complementary structure, so the input impedance is around  $180\Omega$ . As the spiral antenna is a balanced structure, a wideband balun is designed which also can change the impedance from  $50\Omega$  to  $180\Omega$ . The balun structure is fabricated on a

substrate with a dielectric constant of 2.2 and thickness of 2 mm. The inner and outer radius are designed to be  $r_1 = 1$  mm,  $r_2 = 20.5$  mm for 3 turns traditional Archimedean spiral antenna and  $r_1 = 1$  mm,  $r_2 = 27.5$  mm for 4 turns traditional Archimedean spiral antenna.

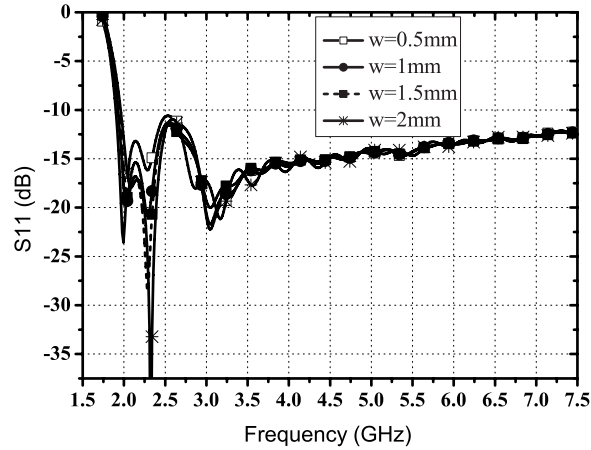
The proposed Archimedean spiral antenna with gap-loading is illustrated in Fig. 1(a). The spiral element of the proposed antenna is the same as the 3 turns Archimedean spiral antenna shown in Fig. 1(b). A circular frame sharing the same centre with the spiral elements introduces a capacitive gap to minimize the size of the proposed antenna. The inner and outer radius of the circular frame are designed to be  $R_1 = 22$  mm and  $R_2 = 23$  mm, so the width of the circular frame is  $w = R_1 - R_2 = 1$  mm, and the width of the gap is  $g = R_1 - r_2 = 1.5$  mm.

### 3. RESULT

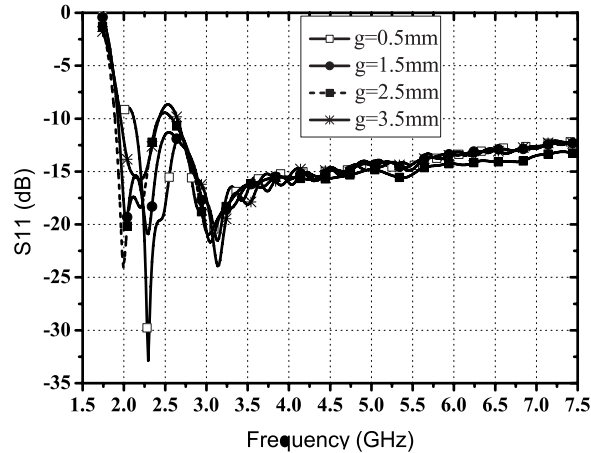
A commercial three-dimension electromagnetic simulator CST based on the finite integration technology (FIT) is used for all simulation. The prototype of the proposed antenna is fabricated and measured. The measured and simulated S parameters of the proposed antenna are shown in Fig. 2, a good agreement is observed. From Fig. 2, it can be seen that the proposed antenna has a lower edge  $f_L = 1.93$  GHz



**Figure 2.** Measured and simulated S parameters of the proposed antenna compared to the different turns traditional Archimedean spiral antenna.



**Figure 3.** Return losses of the proposed antenna with different  $w$ .  $r_1 = 1$  mm,  $r_2 = 20.5$  mm,  $R_1 = 22$  mm, and  $g = 1.5$  mm.

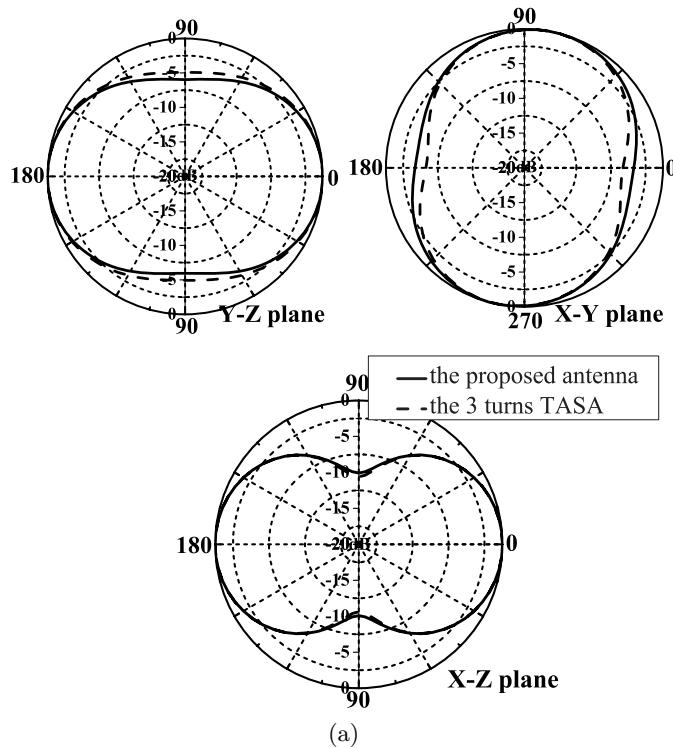


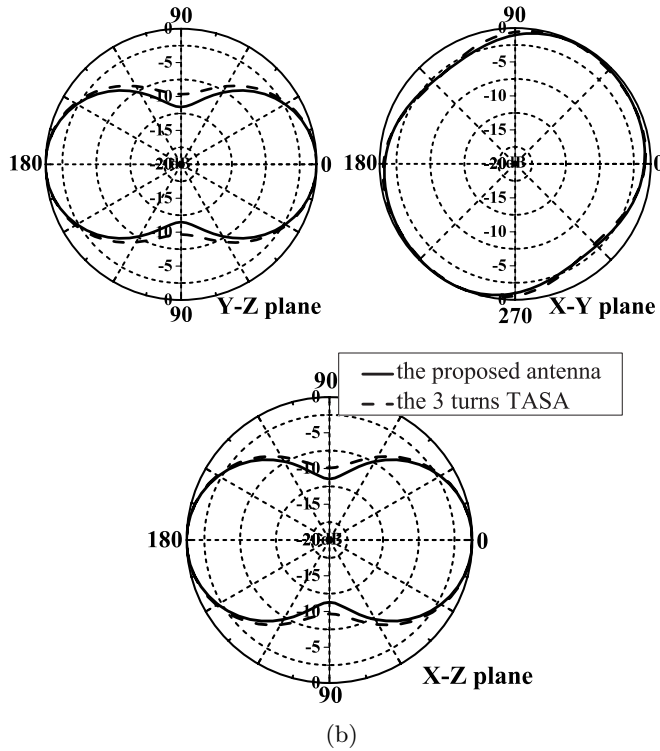
**Figure 4.** Return losses of the proposed antenna with different  $g$ .  $r_1 = 1$  mm,  $r_2 = 20.5$  mm,  $w = 1$  mm.

of the  $|S_{11}| \leq -10$  dB frequency band, in contrast to 2.79 GHz of the traditional 3 turns Archimedean spiral antenna without circular frame. The frequency reduction of initial resonant frequency is 860 MHz. However, the total radius of the proposed antenna increases from 20.5 mm to 23 mm because of adding the circular frame. To compare with the proposed antenna with the same lowest working frequency, the 4 turns Archimedean spiral antenna without gap-loading is studied,

and its lower edge frequency is at 2 GHz, which is almost the same with the proposed gap-loading spiral antenna. The radius of the 4 turns Archimedean spiral antenna is 27.5 mm and the radius of the proposed antenna is reduced to 23 mm, i.e., decreasing by 16% of radius and 30% of area compared with the traditional Archimedean antenna.

The return losses of the proposed antenna for different values of circular frame width  $w$  are shown in Fig. 3. It is found that the  $S_{11}$  of the antenna is not sensitive to the change in  $w$ , so we choose  $w = 1$  mm little narrower than the arm width. Fig. 4 shows the return losses of the Archimedean spiral antenna with gap-loading versus the different gap width  $g$ . It can be seen that the lowest working frequency decreases with an increase in gap width  $g$  and the return loss at higher frequency band is almost unchanged. However, there is a practical limit on increasing the gap width  $g$ , and if increased beyond 2.5 mm, the  $S_{11}$  of the antenna become deteriorative, the best return losses is obtained at  $g = 1.5$  mm. It is easy to conclude that, the gap width  $g$  determines the lowest resonant frequency and the intensity of the coupling between the circular frame and the spiral element, and it mainly leads to the changes at low working frequency.

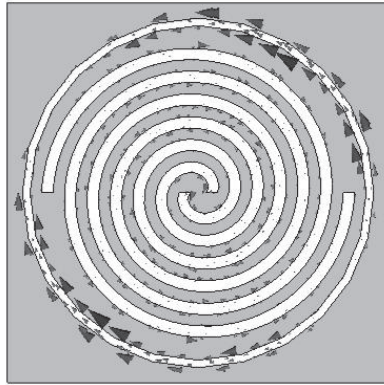




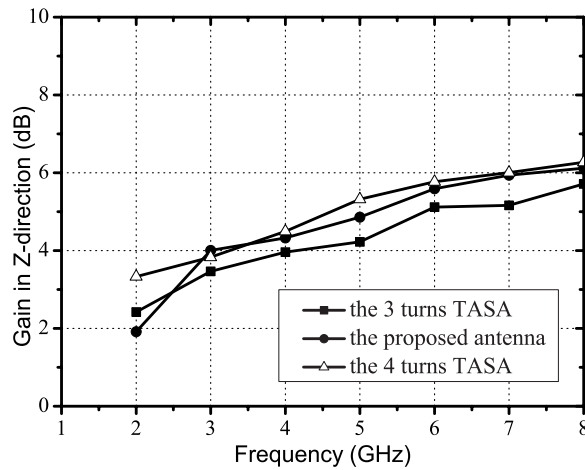
**Figure 5.** Radiation patterns of the proposed antenna compared with those of the 3 turns TASA. (a) 3 GHz, (b) 6 GHz.

Fig. 5 shows the simulated radiation patterns of the proposed Archimedean spiral antenna with gap-loading at 3, 6 GHz, respectively. Each pattern is normalized with respect to the peak gain of the corresponding plane. It is found that the proposed antenna and the traditional Archimedean spiral antenna have almost the same radiation patterns.

Fig. 6 shows the current distributions of the proposed antenna at 1.93 GHz. It is shown that when a quart of the circular frame is about  $\lambda/4$ , a resonant mode appears which can flatten the input impedance at low frequency band, and, hence, lowers the edge frequency of  $S_{11} \leq -10$  dB. Because the currents on the circular frame add constructively to gain increase in  $XZ$ ,  $YZ$  plane, the area of the proposed antenna can be reduced by more than 30% without gain compromise across the whole frequency band [14], which is shown in Fig. 7.



**Figure 6.** Current distribution on the Archimedean spiral antenna with gap-loading at 1.93 GHz.



**Figure 7.** Gain in  $Z$ -direction of the the Archimedean spiral antenna with gap-loading compared with the different turns traditional Archimedean spiral antenna.

#### 4. CONCLUSION

A technical method of gap-loading for miniature Archimedean spiral antenna is presented in this paper, which is derived by adding a circular frame. Compared with the traditional Archimedean spiral antenna with the same lowest working frequency, the area of the proposed one can be reduced by more than 30%. The optimum performance

of the spiral antenna with gap-loading can be obtained by adjusting the gap. This method provides an easy and effective way for spiral antenna miniaturization. Simulated and measured return losses as well as simulated radiation patterns are presented in this paper.

## ACKNOWLEDGMENT

This work was supported by the Youth Foundation of UESTC.

## REFERENCES

1. Zaker, R., Ch. Ghobadi, and J. Nourinia, "A modified microstrip-fed two-step tapered monopole antenna for UWB and WLAN applications," *Progress In Electromagnetics Research*, PIER 77, 137–148, 2007.
2. Sadat, S. and M. Houshmand, "Design of a microstrip square-ring slot antenna filled by an h-shape slot for UWB," *Progress In Electromagnetics Research*, PIER 70, 191–198, 2007.
3. Wang, F. J. and J. S. Zhang, "Wide band cavity-backed patch antenna for PCS/IMT2000/2.4 GHz WLAN," *Progress In Electromagnetics Research*, PIER 74, 39–46, 2007.
4. Turner, E. M, "Spiral slot antenna," WADC, Aerial Reconnaissance Laboratory, Project 4341, Technical note WCLR 55-8, June 1955.
5. Wang, J. J. H., "The spiral as a traveling wave structure for broadband antenna applications," *Electromagnetics*, 20–40, July–August 2000.
6. Wang, Y. J. and C. K. Lee, "Compact and broadband microstrip patch antenna for the 3G IMT-2000 handsets applying styrofoam and shorting-posts," *Progress In Electromagnetics Research*, PIER 67, 173–179, 2007.
7. Sayem, A. T. M. and M. Ali, "Characteristics of a microstrip-fed miniature printed hilbert slot antenna," *Progress In Electromagnetics Research*, PIER 56, 1–18, 2006.
8. Sadat, S., M. Fardis, F. Geran, and G. Dadashzadeh, "A compact microstrip square-ring slot antenna for UWB application," *Progress In Electromagnetics Research*, PIER 67, 173–179, 2007.
9. Saed, M. and R. Yadla, "Microstrip-fed low profile and compact dielectric resonator antennas," *Progress In Electromagnetics Research*, PIER 56, 151–162, 2006.
10. Zhao, G., F. S. Zhang, Y. Song, Z. B. Weng, and Y. C. Jiao,



- “Compact ring monopole antenna with double meander lines for 2.4/5 GHz dual-band operation,” *Progress In Electromagnetics Research*, PIER 67, 173–179, 2007.
11. Naghshvarian-Jahromi, M., “Compact UWB bandnotch antenna with transmission-line-fed,” *Progress In Electromagnetics Research B*, Vol. 3, 283–293, 2008.
  12. Hosseini, S. A., Z. Atlasbaf, and K. Forooraghi, “Two new loaded compact planar ultra-band antennas using defected ground structures,” *Progress In Electromagnetics Research B*, Vol. 2, 165–176, 2008.
  13. Jolani, F. and A. M. Dadgarpour, “Compact m-slot folded patch antenna for WLAN,” *Progress In Electromagnetics Research Letters*, Vol. 3, 35–42, 2008.
  14. Lee M., B. A. Kramer, C.-C. Chen, and J. L. Volakis, “Broadband spiral antenna miniaturization limit,” *Proc. IEEE Antennas and Propagation Society Int. Symp.*, 3701–3704, July 2006.
  15. Li, R. L., E. M. Tentzeris, J. Laskar, V. F. Fusco, and R. Cahill, “Broadband antenna for DCS-1800/IMT-2000 mobile phone handset,” *IEEE Microwave and Wireless Components Letters*, Vol. 12, No. 8, August 2002.
  16. Qu, S. W., C. L. Ruan, B. Z. Wang, and Q. Xue, “Planar bow-tie antenna embedded in circular aperture within conductive frame,” *IEEE Antennas Wireless Propag. Lett.*, Vol. 5, 2006.