

Date of publication xxxx 00, 0000, date of current version xxxx 00, 0000.

Digital Object Identifier 10.1109/ACCESS.2017.Doi Number

A novel nature Inspired meta-heuristic optimization Approach of GWO Optimizer for Optimal reactive power dispatch problems

Raheela Jamal¹, Baohui Men^{1,*}, Noor Habib Khan²

¹ School of Water Resources and Hydropower Engineering, North China Electric Power University, Beijing 102206, China

² School of Renewable Energy, Wind Power, North China Electric Power University, Beijing 102206, China

Corresponding author: First A. Author (e-mail: menbh@ncepu.edu.cn).

“ The authors acknowledge the funds supported by National Key R& D Program of China (Grant No. 2016YFC0401406), and the Famous Teachers Cultivation planning for Teaching of North China Electric Power University (the Fourth Period)”

ABSTRACT In this paper, a novel nature inspired meta heuristic optimization approach of Grey Wolf Optimization (GWO) algorithm is employed to solved the optimal reactive power dispatch (ORPD) problems. Essentially, it is the sub and non-linear optimization problem of optimal power flow (OPF) in which the control parameters of the power networks are optimized. The Grey wolf optimizer (GWO) which is inspired from grey wolves' leadership and hunting behaviors to solve the ORPD problems. For which, the optimizer is tested on two test cases of IEEE30 standards specially, for 13 and 19 variables in order to get three fitness objectives for instance; transmission line losses (P_{losses} , MW), voltage deviation (VD), voltage stability index (VSI) and cost of energy in (\$). During computing all fitness objectives, the minimum fitness values are possibly achieved by the finest settings of control variables. The simulation results are compared with other artificial intelligence methods in previous literature to ensure the superior performance of the GWO for ORPD problem. The consistency of GWO will further be validated through detailed statistical analysis including histogram illustrations, boxplots, empirical CDF plot, probability plot and plot of minimum fitness during each independent trial.

INDEX TERMS Optimal Power Flow (OPF), Optimal Reactive Power Dispatch (ORPD), Grey Wolf Algorithm (GWO), Load Flow Analysis (LFA)

I. INTRODUCTION

The recent span of revisions related to the power systems are mostly attentive to reduce the entire cost of the generation with stable and secure operations. In accumulation, the reduction in transmission line losses with the improved of voltage profile plays a vital part in resolving the optimal reactive power dispatch (ORPD) issues. These tasks can be achieved by improving the settings of control parameters for instance; the reactive outcomes of generator voltages, tap changer of transformers and reactive shunt VAR compensators. While, the contingent constraints such as load bus voltages, generation from the reactive generators and apparent power through transmission lines should be in limits to avoid getting penalties [1].

The mostly objective functions are optimized while resolving the optimal reactive power dispatch issues comprises as; minimization of transmission line losses, voltage deviation, improvement of voltage stability index and minimization of cost of energy. In the initial step of research led to resolve the ORPD problems, there are several

techniques which are used such as; classical methods including the gradient method [2,3], interior point method [4], linear programming and non-linear programming [5], quadratic programming and Newton method [6], Langrangian technique [7] and dynamic programing [8].

However, these techniques have some drawbacks in resolving the complex optimization problem of ORPD such as; trapping in local minima, untimely convergence and algorithmic intricacy. To resolved these cited issues and overwhelmed the weakness these approaches, the scholars/researchers have implemented meta-heuristic and evolutionary techniques such as; evolutionary programming [9], differential evolution algorithm [10], genetic algorithm [11], moth-flame algorithm [12], whale optimization algorithm[13], binary bat algorithm[14], seeker optimization algorithm [15], firefly algorithm [16], chaotic krill herd algorithm [17], jaya algorithm [18], backtracking search algorithm [19], gravitational search algorithm [20], particle swarm optimization [21], invasive weed optimization [22],

imperialist competitive algorithm [23], cuckoo search algorithm [24], improved GWO optimizer [25] and other hybrid solution mechanisms by relating these concepts are studied in [26-33]. While, some hybrid techniques are used to solve the optimal reactive power dispatch problems such as; PSO-GSA algorithm [34], HGAPSO [35], SOA-FS [36].

The paper proposes the practice of a novel meta-heuristic approach based on GWO optimizer which aims to resolve the ORPD problem in the power networks. This technique is based on population and inspired from the conduct of grey wolves. The hunting and the social conduct of grey wolves has proposed in [37]. For GWO simulation, the standard MATPOWER package is used to run the load flow analysis and the objectives of the research are given as follows:

- A novel nature inspired meta-heuristic optimization technique of GWO is tested on IEEE30 Bus Standards with 13 and 19 control variables for solving ORPD problems.
- The aims / objectives of this research are to minimize the power transmission line losses (P_{losses} , MW), voltage deviation (VD), voltage Stability index and the energy cost in \$.
- The validation and verification of the proposed results of GWO optimization algorithm through comparative studies with state-of-the-art methodologies to prove the worth of the scheme.
- The performance of GWO via statistical analysis in term of histogram, probability CDF plots with learning curves is revealed the stability and the robustness of the algorithm.

The rest of body of the paper is set into the following sections: Section 2 deliberates the problem formulation of ORPD, Section 3 represents the methodology of GWO with its pseudocode and graphical abstract, Section 4 describes the results/discussion, Section 5 demonstrates the statistical analysis while Section 6 represents the conclusion of this research.

II. PROBLEM FORMULATION OF OPTIMAL RPD (ORPD)

The fitness objective of the ORPD problem is to minimize the transmission line losses, voltage deviation, voltage stability index and cost of energy. The mathematical formulations of these objectives are described in following sections.

A. POWER LOSSES MINIMIZATION (F_1)

Here, $f(q, p)$ denotes as the first objective function which aims to minimize the transmission line losses in MW. While, the mathematical expression of this function is defined as follows [32]:

$$F_1 = P_{loss}(q, p) = \sum_{i=1}^{nl} P_{loss} \quad (1)$$

The q along with p are defined as the dependent variables vector as well as control variables vector correspondingly. The function solution requirement is to pay attention towards equality and inequality restraints.

$$x(q, p) = 0 \quad (2)$$

$$y(q, p) \leq 0 \quad (3)$$

where, $x(q, p) = 0$ is defined as the equality constraints as well as $y(q, p) \leq 0$ define as the inequality constraints.

The equality restraint stands as the balanced power equation while the inequality restraints are described as generator voltages, tap changer of transformers and reactive shunt VAR compensators.

1) EQUALITY CONSTRAINTS

The equality restraint which represents the power equality of load flow defined that the modification concerning generated power in addition to demand power is equivalent to the power losses. The equality restraint equations proposed in [40] are still effective to give the power balanced of load flow, as follows:

$$P_{Gt,i} - P_{De,i} = V_i \sum_{j \in N_i} V_j (G_{ij} \cos \theta_{ij} + B_{ij} \sin \theta_{ij}) \quad (4)$$

$$Q_{Gt,i} - Q_{De,i} = V_i \sum_{j \in N_i} V_j (B_{ij} \cos \theta_{ij} + G_{ij} \sin \theta_{ij}) \quad (5)$$

where, $P_{De,i}$ and $P_{Gt,i}$ denoted are the real power demand and generation, $Q_{Gt,i}$ and $Q_{De,i}$ are the reactive power generation and demand, V_i and V_j indicate as the voltages at i^{th} and j^{th} load buses correspondingly, while B_{ij} and G_{ij} are the susceptance along with conductance between i^{th} and j^{th} buses respectively.

2) INEQUALITY CONSTRAINTS

The inequality restraints are defined in the following sub sections.

A) GENERATOR CONSTRAINTS:

The bus voltages' generation along with generation of real as well as reactive power need to be limited through their limits as below:

$$\begin{aligned} P_{Gt,i}^{\min} &\leq P_{Gt,i} \leq P_{Gt,i}^{\max} & i = 1, 2, \dots, N_{Gt} \\ Q_{Gt,i}^{\min} &\leq Q_{Gt,i} \leq Q_{Gt,i}^{\max} & i = 1, 2, \dots, N_{Gt} \\ V_{Gt,i}^{\min} &\leq V_{Gt,i} \leq V_{Gt,i}^{\max} & i = 1, 2, \dots, N_{Gt} \end{aligned} \quad (6)$$

where, $P_{Gt,i}^{\min}$, $Q_{Gt,i}^{\min}$ and $V_{Gt,i}^{\min}$ denoted as the minimum limits of active, reactive power generation and voltages, $P_{Gt,i}^{\max}$, $Q_{Gt,i}^{\max}$ and $V_{Gt,i}^{\max}$ are the maximum limits of active, reactive and voltages, while N_{Gt} represents the number of generators.

B) TRANSFORMER TAP SETTING

The formulation of setting of transformer tap limits is defined as follows:

$$T_{ts,i}^{\min} \leq T_{ts,i} \leq T_{ts,i}^{\max} \quad i = 1, \dots, N_{Ts} \quad (7)$$

where, $T_{ts,i}^{\min}$ and $T_{ts,i}^{\max}$ are the upper and lower limits of the transformer tap settings, whereas N_{Ts} represents the number of transformers.

C) REACTIVE SHUNT COMPENSATORS

$$Q_{ct,i}^{\min} \leq Q_{ct,i} \leq Q_{ct,i}^{\max} \quad i = 1, \dots, N_{Ct} \quad (8)$$

Where, $Q_{ct,i}^{\min}$ and $Q_{ct,i}^{\max}$ are upper and lower limits of compensators, while N_{Ct} is the number of compensators.

All the fitness objectives for ORPD problem are needed to be minimize while satisfying the equality and inequality constraints. The number of parameters should be set to optimum values for obtaining such objectives. In ORPD, the inequality restraints are exposed to be considered as the penalty factors which is computed as the following mathematical expression.

$$F_P = f(f_{1,2,3}) + \sum_{i \in N_{qp}} P_{Vge,i} (V_i - V_i^{\lim})^2 + \sum_{i \in N_T} P_{Tc,i} (T_i - T_i^{\lim})^2 + \sum_{i \in N_G} P_{Grp,i} (Q_i - Q_i^{\lim})^2 \quad (9)$$

where, $P_{Vge,i}$, $P_{Tc,i}$ and $P_{Grp,i}$ are denoted as the penalty multiplier factors for voltage, transformer tap and reactive power generation limits. Whereas, the bound restraints of V_i^{\lim} , T_i^{\lim} and Q_i^{\lim} are given as follows:

GENERATOR BOUND CONSTRAINTS:

$$V_i^{\lim} = \begin{cases} V_i^{\min}; V_i > V_i^{\max} \\ V_i^{\min}; V_i < V_i^{\max} \end{cases} \quad (10)$$

TRANSFORMER BOUND CONSTRAINTS

$$T_i^{\lim} = \begin{cases} T_i^{\min}; T_i > T_i^{\max} \\ T_i^{\min}; T_i < T_i^{\max} \end{cases} \quad (11)$$

REACTIVE POWER GENERATION CONSTRAINTS

$$Q_i^{\lim} = \begin{cases} Q_i^{\min}; Q_i > Q_i^{\max} \\ Q_i^{\min}; Q_i < Q_i^{\max} \end{cases} \quad (12)$$

B. MINIMIZATION OF VOLTAGE DEVIATION (F_2)

It is defined as; summation of voltage deviations at the entire buses in the electric networks from the reference values. It is considered as an important index factor in functioning the electric power networks. The mathematical

expression of the second objective of this research is given as follows [40]:

$$F_2 = VD(q, p) = \sum_{i=1}^{nl} [V_t - V_t^{sv}] \quad (13)$$

Where, nl is the number of transmission lines and V_t^{sv} is the stated value which is usually set to 1.0p.u.

C. MINIMIZATION OF VOLTAGE STABILITY INDEX (F_3)

The instability of voltage is one of the most destructive phenomena for the power system that can cause the voltage collapse steadily even immediately. The improvement of voltage stability is equivalent to minimization of voltage stability indicator that normally called L-index at each bus in the power system. The improvement of the voltage stability is carried out by minimizing the highest value of the L-index in the power system at one bus. It is formulated by the given mathematical expression [38]:

$$F_3 = L_j = \left| 1 - \sum_{j=1}^{N_g} Y_{ji} \frac{V_i}{V_j} \right|, \quad j = 1, 2, \dots, N_{Bus} \quad (14)$$

$$L = \max(L_j), \quad j = 1, 2, \dots, N_{Bus} \quad (15)$$

here, L_j is the value of bus j and called L-index, while Y_{ji} is the mutual admittance between bus j and i .

D. MINIMIZATION OF ENERGY COST (F_4)

The computing of minimization of cost is considered as the third fitness objective of this research. The mathematical expression is defined as follows [39]:

$$F_4 = \min(C_{total}) = C_{Energy} \quad (16)$$

$$C_{Energy} = F_1 \times (0.06 \times 365 \times 24) \quad (17)$$

where, the value of 0.06 \$/KWhr cost due to energy losses, 365 represents days/year while 24 indicates the hour/day.

III. METHODOLOGY

This section presents the fundamental concepts of the Grey Wolf Optimizer (GWO), pseudo code and the graphical abstract for the solution to ORPD problems.

A. GREY WOLF OPTIMIZER (GWO)

The Grey Wolf Optimizer is Swarm Intelligence tool. It was first proposed by Mirjalili [37]. The grey wolf optimizer is inspired from the behavior of grey wolves. The grey wolves usually live in a pack of 4-10 wolves. The Group consists of one leader which is on top of its hierarchy. The leaders are alpha wolves which dominate the whole pack and they take decisions for the pack. The alphas (α) are followed by betas (β), they help alphas (α) in decision making and they, too, dominate rest of the pack. The deltas (δ) are third in order and they control rest of the wolves. The omegas (ω) are at last on the hierarchy and they follow the commands from top orders.

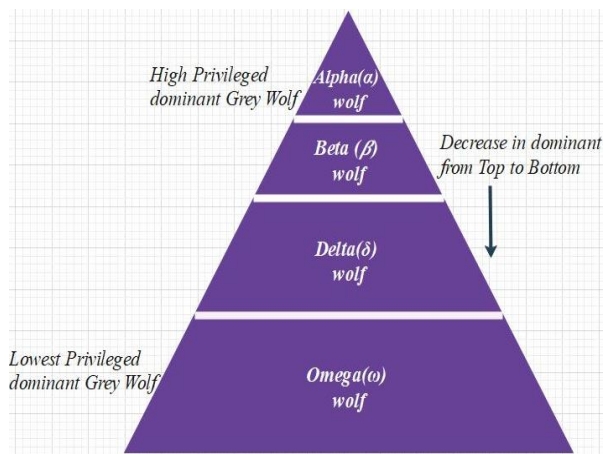

FIGURE 1. The dominance hierarchy of Grey Wolves

The social hierarchy is shown in Fig. 1. The hunting behavior of grey wolves consists of chasing, encircling and attacking the prey. These behaviors help in exploration and exploitation in search space for optimization problems. The mathematical approach of social hierarchy and hunting behavior of grey wolves is explained in this section. To formulate the social hierarchy for grey wolf optimizer, we consider the best solution as the alphas (α). The second-best solution is called beta (β), followed by delta (δ) as the third best solution. The rest of the population is called omega (ω). The hunting in GWO algorithm is focused through (α), (β), as well as (δ) whereas the omega tracks them. The attacking

procedure of the grey wolves comprises numerous phases before they catch the prey. Initially, the wolves tend to encircle the prey to stop her as of moving, this encircling behavior can be represented through the subsequent set of equations:

The hunting behavior of grey wolves comprises of searching, encircling and attacking the prey. The mathematical expression is given as follows:

$$\vec{D} = \left[\vec{C} \cdot X_{Pvl} \rightarrow (t_{iter}) - \vec{X} \rightarrow (t_{iter}) \right] \quad (18)$$

$$X_{ps} \rightarrow (t_{iter} + 1) = \vec{X}_{Pvl} \rightarrow (t_{iter}) - \vec{A} \cdot \vec{D} \quad (19)$$

where, \vec{A} and \vec{D} stand for the vectors coefficient constants, $X_{Pvl} \rightarrow$ is denoted as the vector location of the prey, t_{iter} is donated as iteration, $X_{ps} \rightarrow$ is the position vector of a grey wolf. The encircling equations are able to be acquired through finding the \vec{A} in addition to \vec{C} vectors.

$$\begin{aligned} \vec{A} &= 2a \cdot r_1 - a \\ \vec{C} &= 2 \cdot r_2 \end{aligned} \quad (20)$$

Algorithm 1. Pseudo Code of GWO optimizer for ORPD problems

Inputs: Set no. of iterations, population, set limits of control variable and load case data of IEEE 30 bus for 13 and 19 Control Variables.

Output: Minimization of power losses, Voltage deviation, Voltage Stability Index and Cost of Energy.

Start GWO

Step-1 Swarm (S_{warm}) with set of all possible solutions, known as search agents in n^{th} dimension given as:

$$S_{warm} = [V_{GE,1}, V_{GE,2}, \dots, V_{GE,n}, T_{c,1}, T_{c,2}, \dots, T_{c,n}, Q_{c,1}, Q_{c,1}, \dots, Q_{c,n}]$$

Step-2 Initialize Optimizer by maximum number of iterations with S_{warm} of search agents for given control variables with upper and lower limits.

$$S_j^i(0) = S_j^L + rand(0,1) * (S_j^u - S_j^L)$$

Step-3 Start with random Alpha, Beta and Delta positions of three populations.

$$X_{p,1} \rightarrow, X_{p,2} \rightarrow, X_{p,3} \rightarrow$$

Step-4 Run Load flow for each population and obtain active power losses, voltage deviation, voltage stability index and cost of energy.

Step-5 Update positions of population by using alpha, beta and delta positions and best results stored in three positions.

$$X \rightarrow (t_{iter} + 1) = \frac{X_{p,1} \rightarrow + X_{p,2} \rightarrow + X_{p,3} \rightarrow}{3}$$

Step-6 Check for all limits. Reject constrained violated values.

Step-7 Repeat from Step-4 till max number of iterations is reached.

Step-8 Print results for Best Solutions.

End GWO

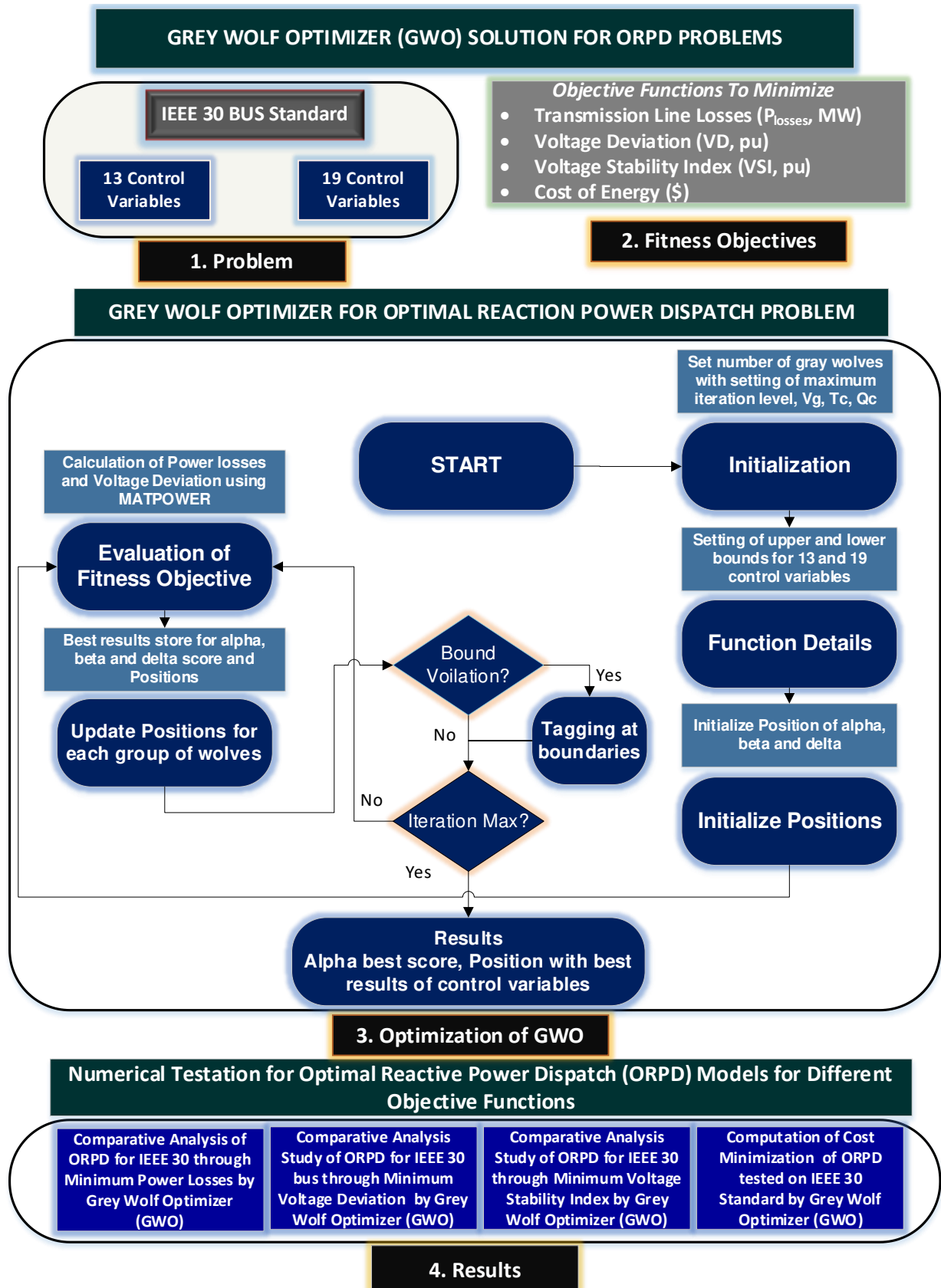

FIGURE 2. Graphical Abstract of GWO Optimizer Scheme Using for Solving ORPD problems based on 13 and 19 variables in IEEE30 Standards Bus System

where, a is in range $[2, 0]$ in addition decreased from 2 to 0 through every iteration, whereas r_1 and r_2 are random vectors between $[0, 1]$.

In each iteration, the three best solutions namely alpha (α), beta(β) and delta(δ) are chosen and other wolves (ω) update their position established on the best solutions. The mathematical formulation is given as follows:

$$\vec{D}_\alpha = \left| C_1 \cdot X_\alpha^\rightarrow(t_{iter}) - \vec{X}(t_{iter}) \right| \quad (21)$$

$$\vec{D}_\beta = \left| C_2 \cdot X_\beta^\rightarrow(t_{iter}) - \vec{X}(t_{iter}) \right| \quad (22)$$

$$\vec{D}_\delta = \left| C_3 \cdot X_\delta^\rightarrow(t_{iter}) - \vec{X}(t_{iter}) \right| \quad (23)$$

The vector positions of the prey be able to be determined established on the alpha (α), beta(β) as well as delta(δ) positions consuming the following equations:

$$\vec{X}_{p,1} = \left| X_\alpha^\rightarrow(t_{iter}) - A_1 \cdot \vec{D}_\alpha \right| \quad (24)$$

$$\vec{X}_{p,2} = \left| X_\beta^\rightarrow(t_{iter}) - A_2 \cdot \vec{D}_\beta \right| \quad (25)$$

$$\vec{X}_{p,3} = \left| X_\delta^\rightarrow(t_{iter}) - A_3 \cdot \vec{D}_\delta \right| \quad (26)$$

The exploration in addition to exploitation of the grey wolf agents depend proceeding the parameter A , through decreasing A half of the iterations remain devoted towards exploration ($|A| \geq 1$). In the meantime, while the ($|A| < 1$) the other half of the iterations are dedicated towards exploitation.

$$X^\rightarrow(t_{iter} + 1) = \frac{X_{p,1}^\rightarrow + X_{p,2}^\rightarrow + X_{p,3}^\rightarrow}{3} \quad (27)$$

IV. RESULTS AND DISCUSSION

A MATLAB programmed for traditional GWO was developed and tested upon different test cases on IEEE30 standards with 13 and 19 variables. The best fitness can possible be achieved by settings of control variables. In this research, the minimum transmission line losses (F_1), minimum voltage deviation (F_2), voltage stability index (F_3) and cost of energy (F_4) are the four objectives to find and discussed while keeping the equality and inequality constraints keep in their limits to avoid get penalties. The details of the study cases are given as follows:

Case A: The GWO optimizer will be tested for IEEE30 standard with 13 variables to minimize different objective functions such as; transmission line losses (Plosses, MW), voltage deviation (VD), voltage stability index (VSI) and cost of energy (\$) respectively.

Case B: The fitness objective in the second study case, the GWO will be tested for IEEE30 standard with 19 variables to get the same fitness objectives.

The Table II describes the function parameters using by GWO for ORPD problems. The comparative analysis will be conducted and discussed in the section for all given fitness objectives with its statistical analysis. The Fig. 3 illustrates the single line diagram of IEEE30 standard system using for both cases (A, B) by using MATPOWER software.

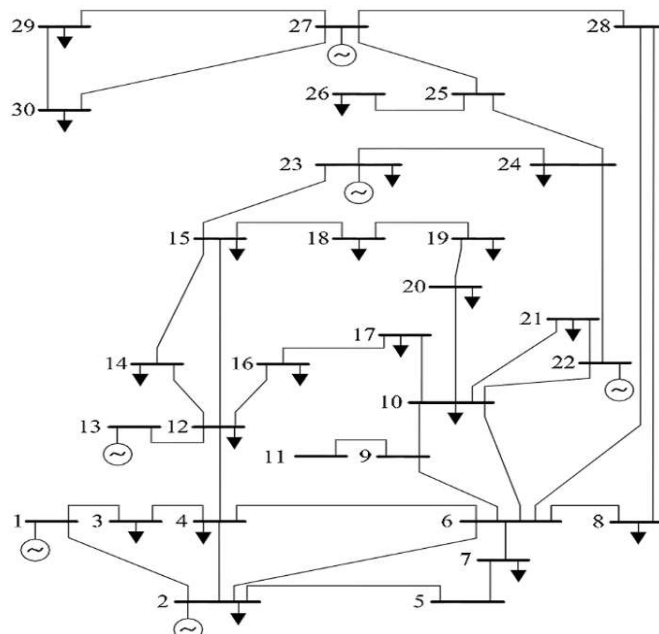

FIGURE 3. Single Line Diagram of IEEE30 Standard Bus System

TABLE I
CONTROL BOUND RESTRAINTS OF IEEE30 BUS (13, 19 VARIABLES)

IEEE 30	V_{GE}^{MAX}	V_{GE}^{MIN}	T_{C1}^{MIN}	T_{C1}^{MAX}	Q_C^{MAX}	Q_C^{MIN}
13, 19	1.1	0.95	0.9	1.05	0	30
Var	1.1	0.95	0.9	1.05	0	30

TABLE II
GWO SELECTION PARAMETERS FOR IEEE30 (13, 19 VARIABLES)

FITNESS OBJECTIVE	F_1 (PLOSS)	F_2 (VD)	F_3 (VSI)	F_4 (Cost)
Search Agent	50	50	50	50
Iterations	200	200	200	200
Independent Runs	50	50	50	50

A. CASE A (IEEE30 WITH 13 VARIABLES)

The number of control variables are taken for IEEE30 standard bus case are 13. The system contains six generator units (V_{GE}), which is connected to buses 1, 2, 5, 8, 11 and 13; four transformers are connected on lines between 6–9, 6–10, 4–12 and 27–28 while three shunt compensators are connected to the bus numbers 10, 20 and 24. The IEEE30 Standard bus system also contains 41 number of branches. The generator voltages, transformer tap settings and VAR injection of the shunt capacitors are considered as the control variables. These restraints of variables are given with the base of 100 MVA. The voltage magnitudes limits of all bus ranges are given between 0.95-1.1p.u, transformer tap settings range from 0.9-1.1 p.u while shunt

capacitor limits are in between the interval of 0 to 30 MVAR. Furthermore, the load demand set for this case is $S = P + jQ = 2.834 + j1.262$ p.u [40].

In the initial step, the proposed algorithm is run at different search agents for 200 iterations with 10 autonomous trails to optimize and get the best solution of GWO optimizer for given ORPD problems. The convergence characteristic curve of GWO for different search agents are given in Fig. 4 for fitness objective F_1 .

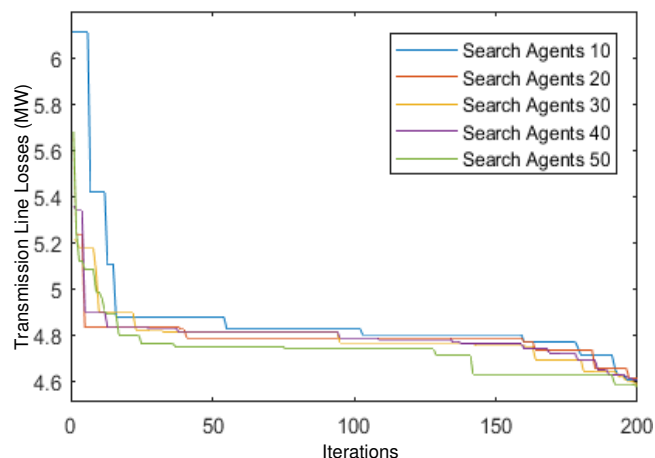

FIGURE 4. GWO Convergence Curve on Different Search Agents for Objective (F_1) IEEE30 (13 Variables) – CASE A

Comparative Analysis. In this section, the simulation of results getting from IEEE30 bus system for 13 variables are compared with the different approaches given in Table III. The GWO results are compared with C-PSO [41], DE [46], MFO [12], MICA-IWO [23], FODPSO [42] and FODPSO-EE [47] algorithms for the optimal reactive power dispatch problems. The limits of control variables are given in Table I, while the results of GWO optimizer gives the best outcomes with satisfying the control limits.

The results are compared to the base case which is taken here 5.663 MW while the outcomes getting from GWO is reported 4.5538 MW which is 19.59% reduced from the base case. The outcomes getting from GWO optimizer is further compared to other algorithms given in Table III. The percentage in reduction of losses from different techniques are given such as; C-PSO is 17.36%, DE is 13.68%, MFO is 19.01%, MICA-IWO is 14.43%, FODPSO is 18.66% and FODPSO-EE is 18.82% while the GWO optimizer is reported to 19.59% respectively.

The Fig. 6(a) illustrates the convergence characteristic curve for minimization of transmission line losses attained by GWO optimizer for ORPD problem. For such purpose, the GWO parameters are set to 50 autonomous runs and 50 search agents with 200 iterations given in Table II, the transmission line losses attained by optimization of GWO reported as 4.5538 MW for Case A. The outcomes of comparative analysis indicated towards the best performance of GWO in case of transmission losses.

The Fig. 6(b) deliberates the mean average, best and worst conditions in cases of transmission line losses minimization in case of power line losses. The best worst and mean values in this case are reported to 4.5538MW, 4.5972MW and 4.5732MW respectively. Here, it is mentioned that the worst case reported in this case.

While, the fitness objective (F_2) in case study A, is to find the voltage deviation (VD), for which GWO has run for 50 search agents with 200 iterations, the detail of function parameters for GWO are given in Table II.

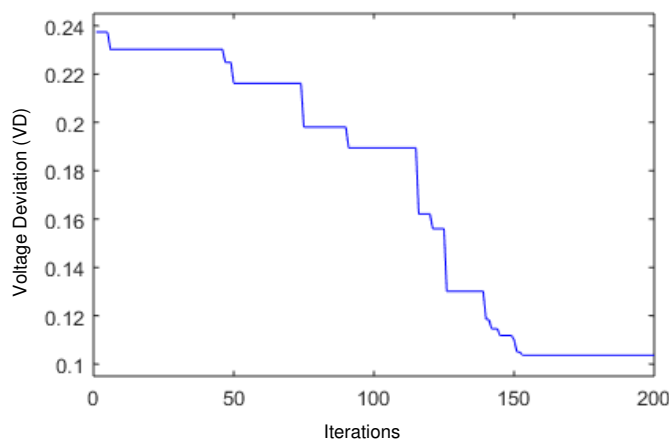

FIGURE 5. Convergence Curve of GWO for Fitness Objective (F_2), IEEE30 (13 Variables) – CASE A

The Fig. 5 illustrates the characteristic curve in case of voltage deviation, the GWO outcomes is reported to minimum value 0.1037p.u. While, the worst and mean values are reported to 0.1427p.u and 0.1254p.u respectively. The outcomes attained by the GWO optimizer in case of minimization of voltage deviation is less reported as compared to the other given solutions in Table III.

The fitness objective (F_3) in study case A is to find the minimization of voltage stability index (VSI). The outcomes of GWO optimizer is reported to 0.1172p.u. While the mean and the worst cases are reported 0.1203p.u and 0.1186p.u respectively. The convergence characteristics of GWO optimizer for this objective is shown in Fig. 7(a) and the detail of comparison given in Table III.

To find the cost of energy minimization is another objective (F_4) of this study Case A. This cost of energy is related to the power losses minimization objective and their values are calculated in. For this cost objective, the GWO parameters selected by Table. 2 and calculate this objective by given Eq. (14-15). The Fig. 7(b) demonstrated the minimum cost of energy curve computed by the GWO optimizer. The minimum cost of the energy is reported to 2.3867E+06 in dollars (\$).

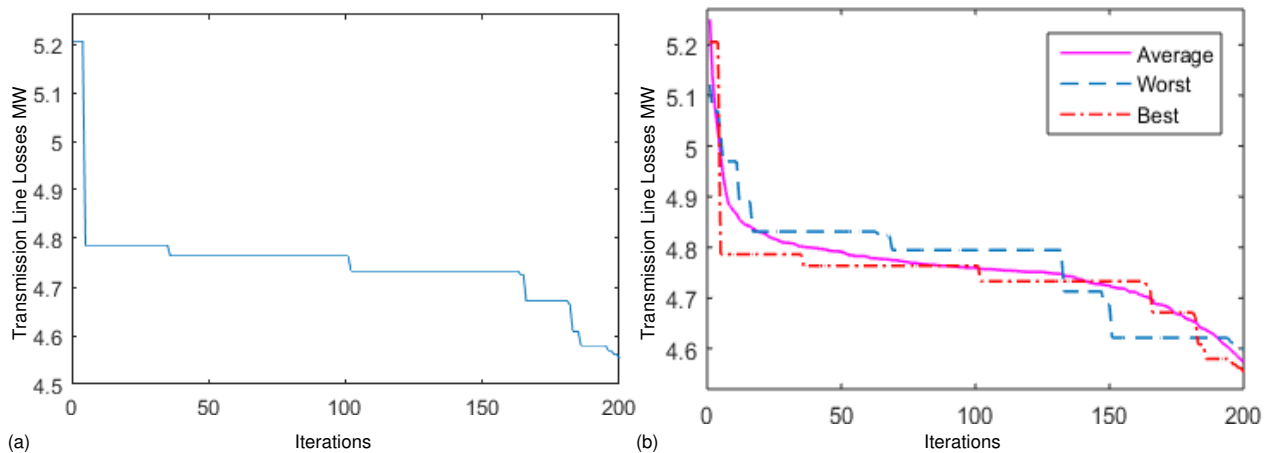

FIGURE 6. (a) Convergence Curve of GWO (b) Mean, Worst and Average Values for Fitness Objective (F_1) IEEE30 (13 Variables) – CASE A

TABLE III
BEST CONTROL VARIABLE SETTINGS FOR FITNESS OBJECTIVES FOR CASE A

Control Variables	C-PSO [41]	DE [46]	MFO [12]	MICA-IWO [23]	FODPSO [42]	FODPSO-EE [47]	GWO
$V_{GE,1}$	1.1000	1.095319	1.1000	1.07972	1.01	1.1	1.1000
$V_{GE,2}$	1.1000	1.085946	1.0946	1.07055	1.04231	1.1	1.0912
$V_{GE,5}$	1.0747	1.062628	1.0756	1.04836	1.0401	1.0833	1.0715
$V_{GE,8}$	1.0867	1.065076	1.772	1.04865	1.0956	1.08533	1.0759
$V_{GE,11}$	1.1000	1.0266	1.0868	1.07518	1.0110	1.0931	1.1000
$V_{GE,13}$	1.1000	1.014253	1.1000	1.07072	1.0491	1.1	1.1000
$T_{C_{6-9}}$	0.99	1.017796	1.04110	1.03	1.0610	1.0434	1.0408
$T_{C_{6-10}}$	1.05	0.979277	0.95007	0.99	0.9295	1.0294	0.9020
$T_{C_{4-12}}$	0.99	0.9797843	0.95541	1	0.9665	1.0752	0.9799
$T_{C_{27-28}}$	0.96	1.008938	0.95754	0.98	0.9555	1.0210	0.9719
$Q_{C,10}$	9.00	20.22359	7.1032	-7	8.4272	4.2822	2.7566
Q_{C20}	30.0	9.584327	30.796	23	25.1542	2.6762	2.9020
Q_{C24}	8.00	13.02992	9.8981	12	9.2331	6.6747	1.7639
$P_{losses, MW}$	4.6801	4.888081	4.5865	4.846	4.606	4.5971	4.5538
TVD, p.u.	NR	NR	0.12154	NR	NR	NR	0.1037
VSI, p.u.	NR	NR	NR	NR	NR	NR	0.1172
Cost in \$	NR	NR	NR	NR	NR	NR	2.3867E+06

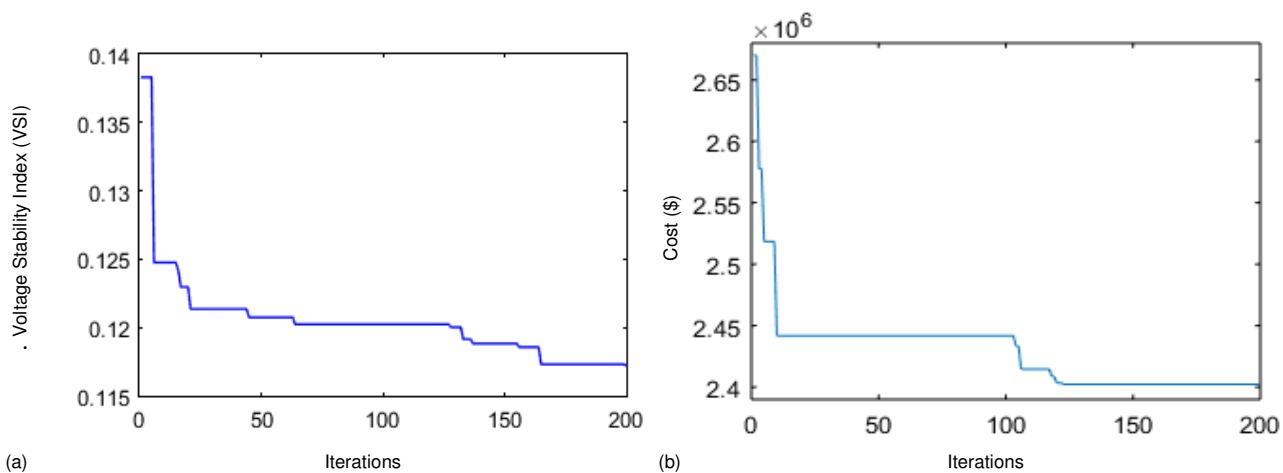

FIGURE 7. (a) Convergence Curve of GWO for Fitness Objective (F_3), (b) Convergence Curve of GWO for Fitness Objective (F_4) – CASE A

B. CASE B (IEEE30 WITH 19 VARIABLES)

For the second Case B, the GWO optimizer is been tested on IEEE30 standard for 19 variables to solve the ORPD problems for four different objective functions. For this case, the IEEE30 standard system considered the same data as previous discussed in Case A for V_{GE} and T_C . But there are 9 shunt reactive compensators considered which are connected to 10, 12, 15,17, 20, 21, 23, 24 and 29 buses while their control limits range interval between 0 to 30 MVar. The restraints of control variables are taken from Table I. While, the loads and transmission line data are taken from [31].

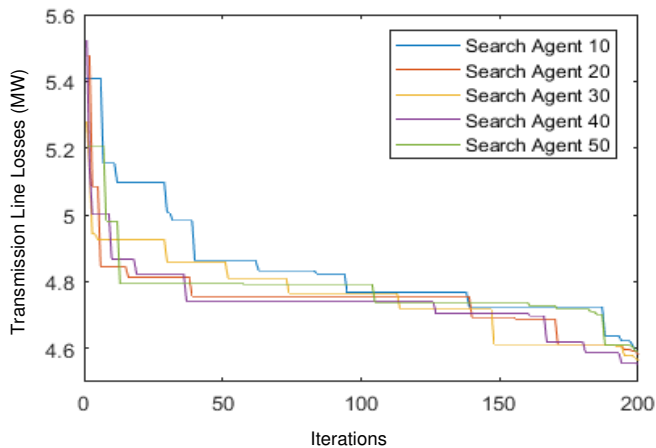

FIGURE 8. GWO Convergence Curve on Different Search Agents for Fitness Objective (F_1), IEEE30 (19 Variables) – CASE B

The grey wolf optimizer (GWO) has been tested on different trials according to changing in number of search agents from 10 to 50 runs with 200 iteration for 10 independent trails given in Fig. 8. The aim of this act, is to get the finest global solution from GWO optimizer. After getting over these trails, the best outcomes are taken from the search agents 50 which is further run for 200 iterations and 50 autonomous trails.

Comparative Analysis. The first fitness objective in Case B is to minimize the transmission line losses (P_{losses} , MW). The outcomes getting from GWO optimizer is further compared to the base case 5.811 MW and other optimization techniques given in Table IV.

By applying the grey wolf optimization (GWO) strategy, the fitness objective F_1 is reduced from the based case 5.811 MW to 4.5185 MW and reduction in losses reported to 22.24%. The GWO optimizer outcomes is further compared to different techniques which are reported such as; GSA [43] is 14.381%, TLBO [45] is 6.85%, FA [36] is 17.92%, GSA-SQP [44] is 21.82%, MFO [12] is 21.86 and DE [46] is 21.61% respectively.

The convergence curve of GWO tested for the transmission line losses is given in Fig. 10(a). The GWO has run on its best trail of 50 search agents with 200 iterations for its better performance, the outcomes of GWO has been reported to 4.5185 MW. The overall results demonstrate

towards the better performance of GWO optimizer for ORPD problems in this case. It can also be concluded that the GWO technique is able to determine the near global solution. The results given in Table 4 also showed that the bound limits of control variables were in the limits.

The outcomes of learning curve in Fig. 10(b) are given in form of average, worst and best. These values are reported 4.5552MW, 4.6284MW and 4.5185MW respectively. The worst value in this case are reported less to the base case which endorse towards the best performance and solution achieved by GWO optimizer.

The second fitness objective in Case B, is to find the voltage deviation (VD). For this purpose, the parameter selection for GWO optimizer is attained from Table II.

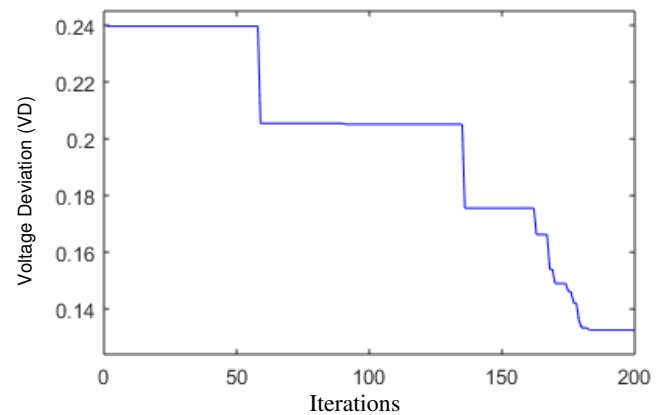

FIGURE 9. Convergence Curve of GWO for Fitness Objective (F_2), IEEE30 (19 Variables) – CASE B

The Fig. 9 is demonstrated the convergence curve for the best outcome achieved by GWO in case of voltage deviation. The results attained by the GWO optimizer in case of minimization of voltage deviation is reported to 0.1325p.u which is less to the base case 1.1501p.u. The outcomes attained by the GWO optimizer in case of minimization of voltage deviation is less reported as compared to the other given solution given in Table IV, which indicates the best optimization solution achieved by the GWO optimizer.

The third objective in this study Case B is to find the minimization of voltage stability index (VSI). The outcomes of GWO optimizer is reported to 0.1125p.u and shown in Fig. 11(a) while the values of the results are given in Table IV.

The results indicated towards the best outcome attained by the GWO optimizer in this case and the results are better reported from GSA, TLBO and DE algorithm given in Table IV. The fourth objective for this study Case B is to find the minimum cost of energy.

The Fig. 11(b) describes cost of energy minimization curve for fitness objection (F_4). For, this objective the selection of GWO parameters taken from Table II. The minimum energy cost is reported to 2.3997E+06 (\$).

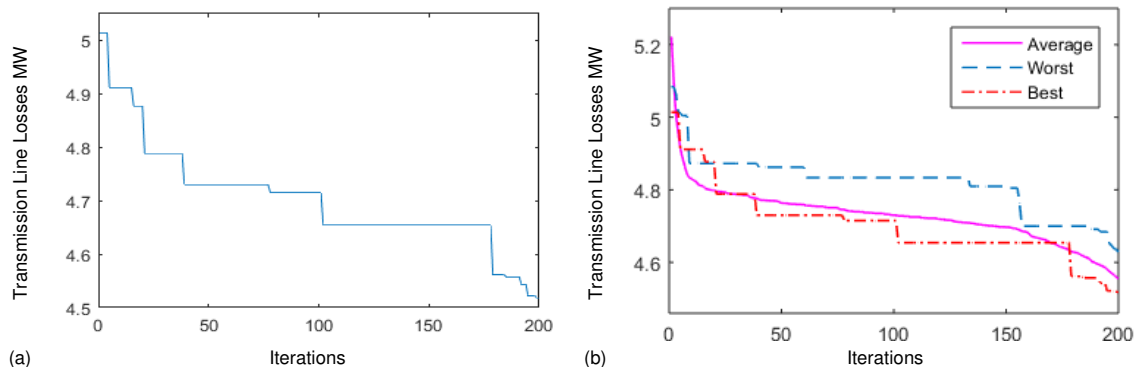

FIGURE 10. (a) Convergence Curve of GWO (b) Mean, Worst and Average Values for Objective (F_1) IEEE30 (19 Variables) – CASE B

TABLE IV
BEST CONTROL VARIABLE SETTINGS FOR MINIMIZATION OF FITNESS OBJECTIVE CASE B

Control Variables	GSA [43]	TLBO [45]	FA [36]	GSA-SQP [44]	MFO [12]	DE [46]	GWO
V_{G1}	1.1	1.06	1.1	1.10000	1.1000	1.1000	1.1
V_{G2}	1.1	1.08	1.0644	1.09432	1.0943	1.0931	1.0946
V_{G5}	1.1	1.07	1.07455	1.07479	1.0747	1.0736	1.0749
V_{G8}	1.1	1.08	1.0869	1.07671	1.0766	1.0756	1.0787
V_{G11}	1.1	1.07	1.09164	1.10000	1.1000	1.1000	1.1
V_{G13}	1.1	1.09	1.099	1.10000	1.1000	1.1000	1.0950
T_{11}	0.9	0.93	1	1.04021	1.0433	1.0465	1.0414
T_{12}	0.9	0.9318	0.94	0.90000	0.9000	0.9097	0.9126
T_{15}	0.9	0.95	1	0.97871	0.97912	0.9867	1.0269
T_{36}	1.019538	0.9331	0.97	0.96611	0.96474	0.9689	0.9891
Q_{C10}	5	0.03	3	5.00000	0.0500	5.0000	2.8072
Q_{C12}	5	0.0466	4	5.00000	0.0500	5.0000	1.5266
Q_{C15}	5	0.0392	3.3	5.00000	0.048055	5.0000	2.7158
Q_{C17}	5	0.0464	3.5	5.00000	0.0500	5.0000	2.8099
Q_{C20}	5	0.0051	3.9	5.00000	0.040263	4.4060	2.2453
Q_{C21}	5	0.02	3.2	5.00000	0.0500	5.0000	0.3991
Q_{C23}	5	0.0101	1.3	3.70176	2.5193	2.8004	1.6841
Q_{C24}	5	0.0043	3.5	5.00000	0.0500	5.0000	2.3217
Q_{C29}	5	0.0016	1.42	2.68988	0.021925	2.5979	2.6973
P_{loss} , MW	4.975298	5.4129	4.7694	4.54271	4.5410	4.5550	4.5185
TVD, pu	0.215793	1.8586	1.9542	2.00789	2.0316	1.9598	0.1325
VSI, pu	0.136844	0.1252	NR	NR	NR	0.5513	0.1125
Cost in \$	NR	NR	NR	NR	NR	NR	2.3997E+06

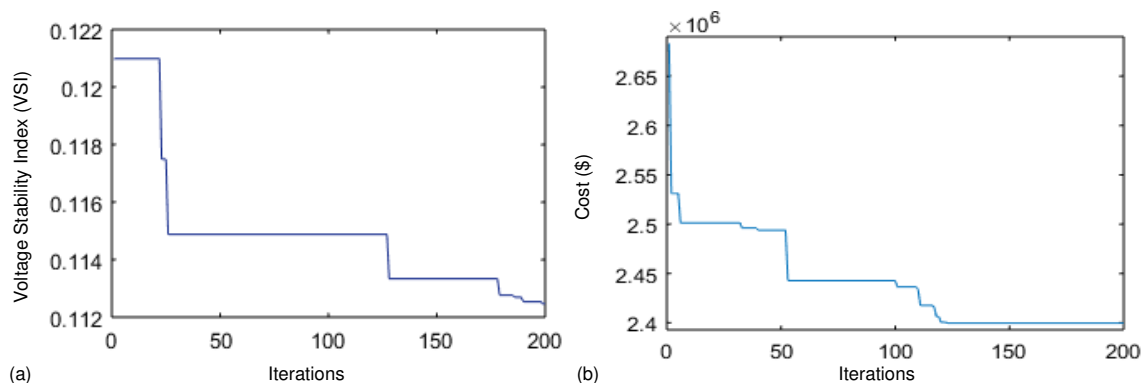

FIGURE 11. (a) Convergence Curve of GWO for Fitness Objective (F_3), (b) Convergence Curve of GWO for Fitness Objective (F_4)

V. STATISTICAL ANALYSIS

In this segment, the performance of the proposed grey wolf optimizer (GWO) is further studied through the comparative analysis with its statistics considering for the two test cases of IEEE 30 with 13 and 19 variables for optimal RPD problems. According to the stochastic nature of the GWO, the outcomes getting from the GWO are different from one another. Therefore, the 50 independent runs are carried out with 50 search agents with 200 iterations to check the inference on GWO to get the better solution for ORPD problem.

The statistical analysis is performed based on boxplot analysis, histogram analysis, empirical CDF analysis with minimum fitness. The results demonstrate in sub Figs 6(a) and 10(a) are for minimization of transmission line losses (Plosses, MW), Figs. 5 and 9 demonstrates the voltage deviation (VD) minimization, sub Figs. 7(a) and 11(a) illustrates the minimization of voltage stability index (VSI), while sub Figs. 7(b) and 11(b) are for the cost of energy

minimization. The minimum fitness in sub Figs. 12(a)-29(a) indicates the minimum difference in all test cases determined the substantial precision of the GWO optimizer. The sub Figs. 12(b)-19(b) histogram plots demonstrated towards the best outcomes taken from the GWO which is recorded less as compared to the based case for given test cases. The sub Figs. 12(c)-19(c) probability empirical CDF curve indicated that almost hundred percent of the autonomous runs gives the fitness less than the base case. While, the sub Figs. 12(d)-19(d) demonstrated the dispersal of data where values and outliers are much closer to the average gauge consist the precise optimization getting from the GWO. For discussing all this statistical analysis and studies, it is depicted that the results demonstrate the robustness consistency and stability of GWO optimizer and also is been observed for the better solution to ORPD problems.

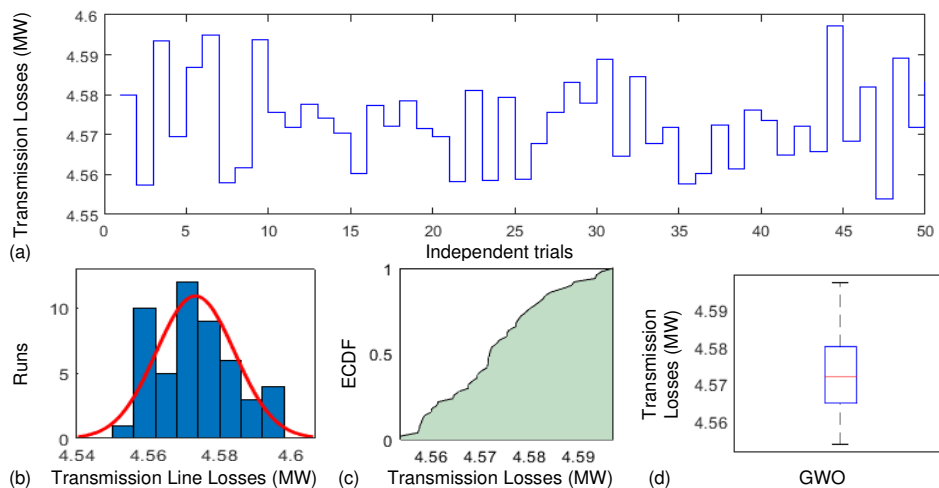

FIGURE 12. Statistical Analysis of GWO for Transmission Losses Minimization on IEEE30 Bus with 13 Variables – CASE A

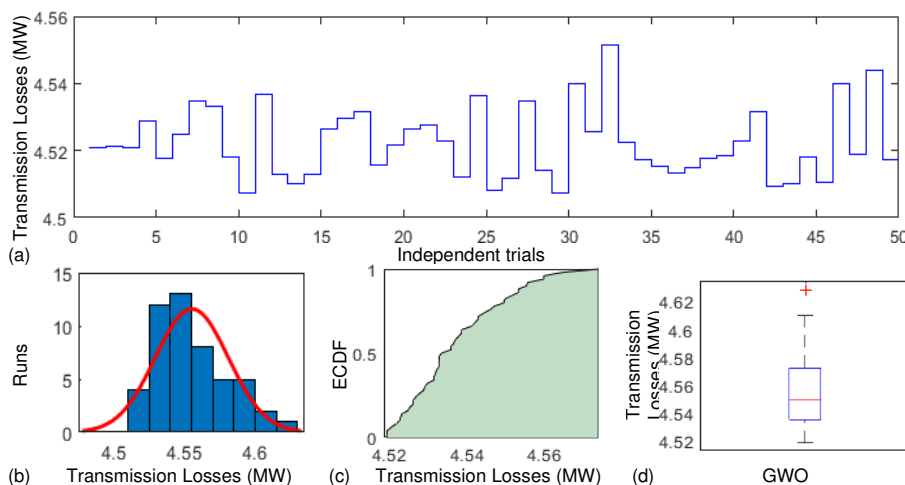

FIGURE 13. Statistical Analysis of GWO for Transmission Losses Minimization on IEEE30 Bus for 19 Variables – CASE B

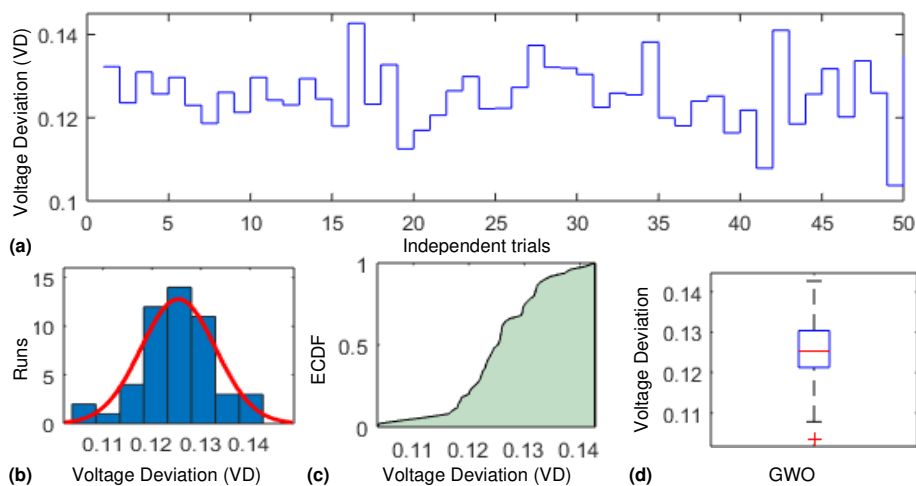

FIGURE 14. Statistical Analysis of GWO for Voltage Deviation on IEEE-30 Bus with 13 Control Variables – CASE A

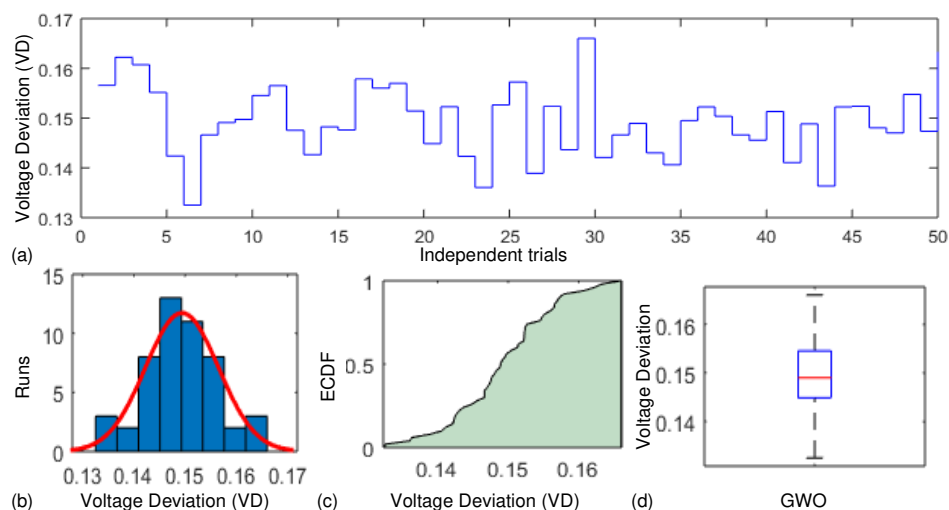

FIGURE 15. Statistical Analysis of GWO for Voltage Deviation on IEEE-30 Bus for 19 Control Variables– CASE B

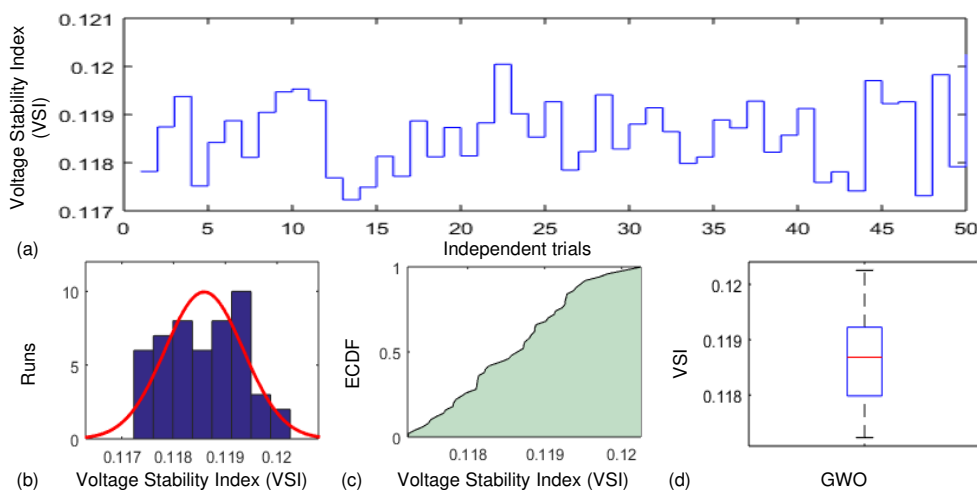

FIGURE 16. Statistical Analysis of GWO for Voltage Stability Index on IEEE30 Bus with 13 Variables– CASE A

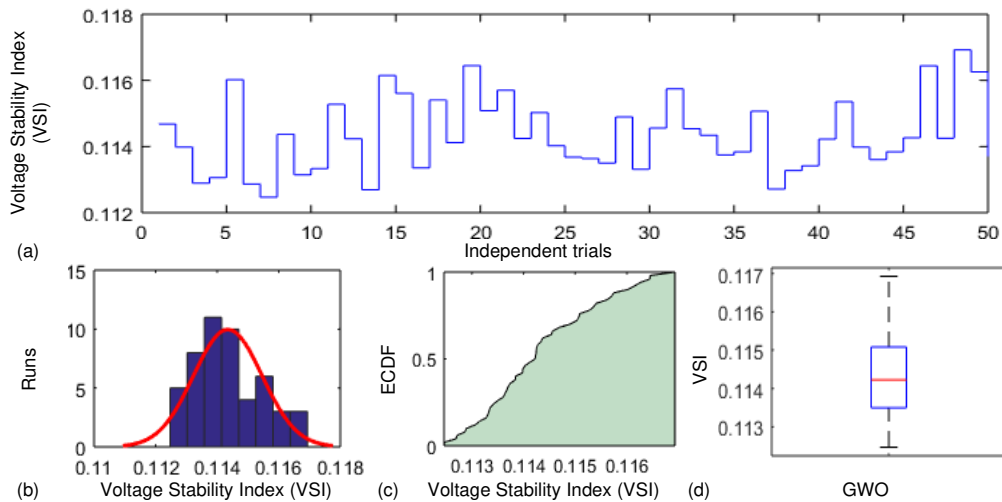

FIGURE 17. Statistical Analysis of GWO, Voltage Stability Index on IEEE30 with 19 Variables– CASE B

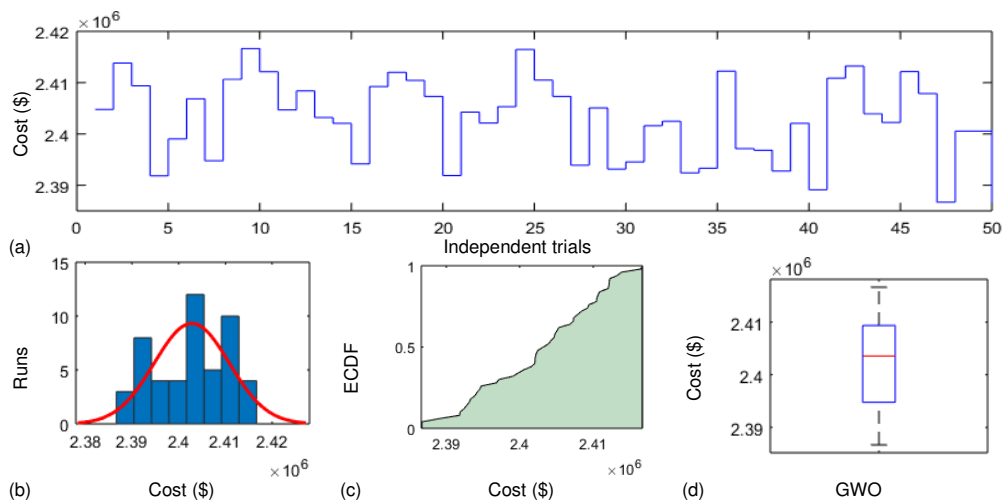

FIGURE 18. Statistical Analysis of GWO for Cost Minimization on IEEE30 Bus with 13 Variables– CASE A

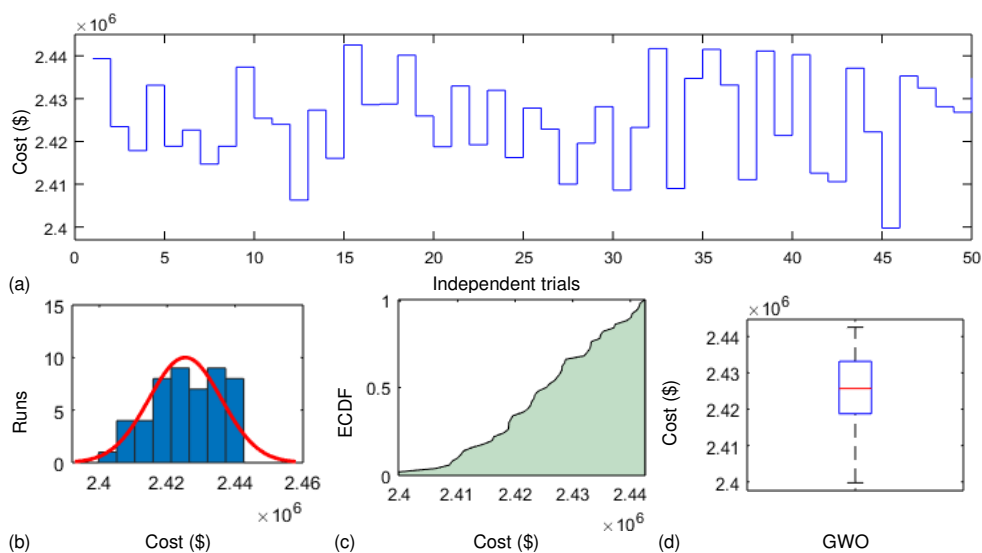

FIGURE 19. Statistical Analysis of GWO for Cost Minimization on IEEE30 Bus for 19 Variables – CASE B

VI. CONCLUSION

In the research, the nature inspired metaheuristic approach of GWO is successfully employed to solved ORPD problems for two given Cases A, B. The numerical results of GWO are tested with other existing methods, namely, C-PSO, DE, MFO, FODPSO, MICA-IWO, MFO, DE, FA, GSA, GSA-SQP and TLBO, to validate the performance of the proposed GWO optimizer. The simulation results showed that GWO optimizer is effective and efficient approach for solving the ORPD problems. When compared with the best results of other techniques, GWO optimizer is observed to be more effective as the total transmission line losses, voltage deviation and cost are the minimum relative to others.

The best outcomes attained by GWO optimizer for both A and B cases are reported such as; minimization of transmission line losses 4.5324 MW and 4.5185 MW with 19.59% and 22.24% reduction in power losses to the base case, voltage deviation values are reported to 0.1037p.u. and 0.1325p.u, voltage stability index values are reported to 0.1175p.u and 0.1125p.u while the cost of energy are reported to 2.3867E+06\$ and 2.3997E+06\$ respectively.

To summarize the overall statistical analysis indicates towards the robustness, effectiveness and efficacy of the GWO optimizer. In future, by utilization of GWO optimizer, it could be more possible to solve the complex and non-linear problems in the field of science and technology.

VII. REFERENCES

- [1] Villa-Acevedo, W.M., López-Lezama, J.M. and Valencia-Velásquez, J.A., 2018. A novel constraint handling approach for the optimal reactive power dispatch problem. *Energies*, 11(9), p.2352.
- [2] Mansour, M.O. and Abdel-Rahman, T.M., 1984. Non-linear VAR optimization using decomposition and coordination. *IEEE transactions on power apparatus and systems*, (2), pp.246-255.
- [3] Grudinin, N., 1998. Reactive power optimization using successive quadratic programming method. *IEEE Transactions on Power Systems*, 13(4), pp.1219-1225.
- [4] Granville, S., 1994. Optimal reactive dispatch through interior point methods. *IEEE Transactions on power systems*, 9(1), pp.136-146.
- [5] Kirschen, D.S. and Van Meeteren, H.P., 1988. MW/voltage control in a linear programming based optimal power flow. *IEEE Transactions on Power Systems*, 3(2), pp.481-489.
- [6] Acha, E., Ambriz-Perez, H. and Fuerte-Esquivel, C.R., 2000. Advanced transformer control modelling in an optimal power flow using Newton's method. *IEEE Transactions on power Systems*, 15(1), pp.290-298.
- [7] Santos, A.J. and Da Costa, G.R.M., 1995. Optimal-power-flow solution by Newton's method applied to an augmented Lagrangian function. *IEE Proceedings-Generation, Transmission and Distribution*, 142(1), pp.33-36.
- [8] Lu, F.C. and Hsu, Y.Y., 1995. Reactive power/voltage control in a distribution substation using dynamic programming. *IEE Proceedings-Generation, Transmission and Distribution*, 142(6), pp.639-645.
- [9] Mallipeddi, R., Jeyadevi, S., Suganthan, P.N. and Baskar, S., 2012. Efficient constraint handling for optimal reactive power dispatch problems. *Swarm and Evolutionary Computation*, 5, pp.28-36.
- [10] Ghasemi, M., Ghanbarian, M.M., Ghavidel, S., Rahmani, S. and Moghaddam, E.M., 2014. Modified teaching learning algorithm and double differential evolution algorithm for optimal reactive power dispatch problem: a comparative study. *Information Sciences*, 278, pp.231-249.
- [11] Subbaraj, P. and Rajnarayanan, P.N., 2009. Optimal reactive power dispatch using self-adaptive real coded genetic algorithm. *Electric Power Systems Research*, 79(2), pp.374-381.
- [12] Mei, R.N.S., Sulaiman, M.H., Mustaffa, Z. and Daniyal, H., 2017. Optimal reactive power dispatch solution by loss minimization using moth-flame optimization technique. *Applied Soft Computing*, 59, pp.210-222.
- [13] Ben oualid Medani, K., Sayah, S. and Bekrar, A., 2018. Whale optimization algorithm based optimal reactive power dispatch: A case study of the Algerian power system. *Electric Power Systems Research*, 163, pp.696-705.
- [14] Agbugba, E.E., 2017. Hybridization of particle Swarm Optimization with Bat Algorithm for optimal reactive power dispatch (Doctoral dissertation).
- [15] Dai, C., Chen, W., Zhu, Y. and Zhang, X., 2009. Reactive power dispatch considering voltage stability with seeker optimization algorithm. *Electric Power Systems Research*, 79(10), pp.1462-1471.
- [16] Rajan, A. and Malakar, T., 2015. Optimal reactive power dispatch using hybrid Nelder–Mead simplex based firefly algorithm. *International Journal of Electrical Power & Energy Systems*, 66, pp.9-24.
- [17] Mukherjee, A. and Mukherjee, V., 2016. Chaotic krill herd algorithm for optimal reactive power dispatch considering FACTS devices. *Applied Soft Computing*, 44, pp.163-190.
- [18] Barakat, A.F., El-Sehiemy, R.A., Elsaid, M. and Osman, E., 2018. Solving reactive power dispatch problem by using JAYA optimization algorithm. In *International Journal of Engineering Research in Africa* (Vol. 36, pp. 12-24). Trans Tech Publications Ltd.
- [19] Shaheen, A.M., El-Sehiemy, R.A. and Farrag, S.M., 2016. Optimal reactive power dispatch using backtracking search algorithm. *Australian Journal of Electrical and Electronics Engineering*, 13(3), pp.200-210.
- [20] Shaw, B., Mukherjee, V. and Ghoshal, S.P., 2014. Solution of reactive power dispatch of power systems by an opposition-based gravitational search algorithm. *International Journal of Electrical Power & Energy Systems*, 55, pp.29-40.
- [21] Singh, R.P., Mukherjee, V. and Ghoshal, S.P., 2015. Optimal reactive power dispatch by particle swarm optimization with an aging leader and challengers. *Applied Soft Computing*, 29, pp.298-309.
- [22] Nayak, M.R., Krishnanand, K.R. and Rout, P.K., 2011, December. Optimal reactive power dispatch based on Adaptive Invasive Weed Optimization algorithm. In *2011 International Conference on Energy, Automation and Signal* (pp. 1-7). IEEE.
- [23] Ghasemi, M., Ghavidel, S., Ghanbarian, M.M. and Habibi, A., 2014. A new hybrid algorithm for optimal reactive power dispatch problem with discrete and continuous control variables. *Applied soft computing*, 22, pp.126-140.
- [24] Le, D.A. and Vo, D.N., 2016. Cuckoo Search Algorithm for Minimization of Power Loss and Voltage Deviation. *International Journal of Energy Optimization and Engineering (IJEEO)*, 5(1), pp.23-34.
- [25] Taha, I.B. and Elattar, E.E., 2018. Optimal reactive power resources sizing for power system operations enhancement based on improved grey wolf optimiser. *IET Generation, Transmission & Distribution*, 12(14), pp.3421-3434.
- [26] Abualigah, L.M.Q., 2019. *Feature selection and enhanced krill herd algorithm for text document clustering* (pp. 1-165). Berlin: Springer.
- [27] Abualigah, L.M.Q. and Hanandeh, E.S., 2015. Applying genetic algorithms to information retrieval using vector space model. *International Journal of Computer Science, Engineering and Applications*, 5(1), p.19.
- [28] Abualigah, L.M. and Khader, A.T., 2017. Unsupervised text feature selection technique based on hybrid particle swarm optimization algorithm with genetic operators for the text clustering. *The Journal of Supercomputing*, 73(11), pp.4773-4795.
- [29] Abualigah, L.M., Khader, A.T. and Hanandeh, E.S., 2018. Hybrid clustering analysis using improved krill herd algorithm. *Applied Intelligence*, 48(11), pp.4047-4071.

- [30] Abualigah, L.M., Khader, A.T. and Hanandeh, E.S., 2018. A combination of objective functions and hybrid krill herd algorithm for text document clustering analysis. *Engineering Applications of Artificial Intelligence*, 73, pp.111-125.
- [31] Abualigah, L.M., Khader, A.T. and Hanandeh, E.S., 2018. A new feature selection method to improve the document clustering using particle swarm optimization algorithm. *Journal of Computational Science*, 25, pp.456-466.
- [32] Abualigah, L.M., Khader, A.T., Hanandeh, E.S. and Gandomi, A.H., 2017. A novel hybridization strategy for krill herd algorithm applied to clustering techniques. *Applied Soft Computing*, 60, pp.423-435.
- [33] Jamal, R.; Men, B.; Khan, N.H.; Raja, M.A.Z. Hybrid Bio-Inspired Computational Heuristic Paradigm for Integrated Load Dispatch Problems Involving Stochastic Wind. *Energies* 2019, 12, 2568.
- [34] Lenin, K., Reddy, B.R. and Kalavathi, M.S., 2014. A new hybrid PSO-GSA algorithm for solving optimal reactive power dispatch problem. *International Journal of Mechatronics, Electrical and Computer Technology*, 4(10), pp.111-125.
- [35] Kapse, S.S.S., Daigavane, M.B. and Daigavane, P.M., 2018. Improvement of ORPD Algorithm for Transmission Loss Minimization and Voltage Control Using UPFC by HGAPSO Approach. *Journal of the Institution of Engineers (India): Series B*, 99(6), pp.575-585.
- [36] Tuba, M. and Bacanin, N., 2014. Improved seeker optimization algorithm hybridized with firefly algorithm for constrained optimization problems. *Neurocomputing*, 143, pp.197-207.
- [37] Mirjalili, S., Mirjalili, S.M. and Lewis, A., 2014. Grey wolf optimizer. *Advances in engineering software*, 69, pp.46-61.
- [38] Rabiee, A., Vanouni, M. and Parniani, M., 2012. Optimal reactive power dispatch for improving voltage stability margin using a local voltage stability index. *Energy Conversion and Management*, 59, pp.66-73.
- [39] Raj, S. and Bhattacharyya, B., 2018. Optimal placement of TCSC and SVC for reactive power planning using Whale optimization algorithm. *Swarm and Evolutionary Computation*, 40, pp.131-143.
- [40] N. H. Khan, Y. Wang, D. Tian, M. A. Z. Raja, R. Jamal and Y. Muhammad, "Design of Fractional Particle Swarm Optimization Gravitational Search Algorithm for Optimal Reactive Power Dispatch Problems," in *IEEE Access*, doi: 10.1109/ACCESS.2020.3014211.
- [41] Khorsandi, A., Alimardani, A., Vahidi, B. and Hosseini, S.H., 2011. Hybrid shuffled frog leaping algorithm and Nelder-Mead simplex search for optimal reactive power dispatch. *IET generation, transmission & distribution*, 5(2), pp.249-256.
- [42] Muhammad, Y., Khan, R., Ullah, F., ur Rehman, A., Aslam, M.S. and Raja, M.A.Z., 2019. Design of fractional swarming strategy for solution of optimal reactive power dispatch. *Neural Computing and Applications*, pp.1-18.
- [43] Duman, S., Sönmez, Y., Güvenç, U. and Yörükeren, N., 2012. Optimal reactive power dispatch using a gravitational search algorithm. *IET generation, transmission & distribution*, 6(6), pp.563-576.
- [44] Radosavljevic, J. and Jevtic, M., 2016. Solution of optimal reactive power dispatch by a hybrid GSA-SQP algorithm. *Elektronika ir Elektrotehnika*, 22(3), pp.3-6.
- [45] Mandal, B. and Roy, P.K., 2013. Optimal reactive power dispatch using quasi-oppositional teaching learning based optimization. *International Journal of Electrical Power & Energy Systems*, 53, pp.123-134.
- [46] Abou El Ela, A.A., Abido, M.A. and Spea, S.R., 2011. Differential evolution algorithm for optimal reactive power dispatch. *Electric Power Systems Research*, 81(2), pp.458-464.
- [47] Y. Muhammad, R. Khan, M. A. Z. Raja, F. Ullah, N. I. Chaudhary and Y. He, "Design of Fractional Swarm Intelligent Computing With Entropy Evolution for Optimal Power Flow Problems," in *IEEE Access*, vol. 8, pp. 111401-111419, 2020, doi: 10.1109/ACCESS.2020.3002714.



RAHEELA JAMAL was born in Rawalpindi, Punjab, Pakistan. She received her bachelor degree BE in Electronics Engineering from Wah Engineering College Wah Cantt Pakistan. She studied MS Electrical Engineering in Bahria University Islamabad, Pakistan from 2013 to 2016. Presently, she is the Ph.D. student at the School of Renewable Energy, North China Electric Power University, Beijing, China from 2017. She also Serve as Lecture at ISRA University for Electrical Engineering Students

from 2014 till 2017. Her research interests include economic load dispatch, hydrothermal scheduling, wind power system, and optimal reactive power dispatch problems.

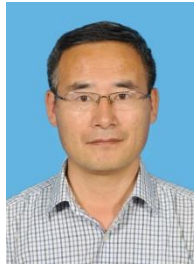

BAOHUI MEN was born in 1973 at Suiling, Heilongjiang province, Chian. Professor, doctoral supervisor. He received his bachelor degree in Agricultural water conservancy engineering in July 1998 and his master degree in Agricultural soil and water engineering in July 2001 from Northeast agricultural university, Harbin, China. He received his Ph. D degree in Hydrology and Water resources from Sichuan university, Chengdu, China, in June 2004, and he received his Postdoctoral in Institute of geographic sciences and resources, Chinese academy of sciences. He joined the School of Renewable Energy in North China Electric Power University in 2007. His research interests include the optimization methods for continuous and discrete optimization problems, and its application in renewable energy and water resources system.

NOOR HABIB KHAN (M'87) born in Rawalpindi, Punjab, Pakistan. He received his MSEE degree in Electrical Engineering from Bahria University Islamabad, Pakistan, in 2013 to 2015. He is the Ph.D. student Wind Power department at the School of Renewable Energy, North China Electric Power University, Beijing, China from 2018. His current research interests include nonlinear model predictive control, its stability analysis, and its application in wind energy conversion systems. He shows his more interest on power systems, stability and control, flexible AC transmission system with ORPD and economic dispatch problems and optimization techniques, optimization methods for continuous and discrete optimization problems, and their applications in wind energy, wind turbine design and manufacturing.

