

## A PARTICLE VELOCITY MICROPHONE FOR THE SONG OF SMALL INSECTS AND OTHER ACOUSTIC MEASUREMENTS

By H. C. BENNET-CLARK\*

*Department of Zoology, South Parks Road, Oxford, OX1 3PS*

*Accepted 8 August 1983*

Conventional particle velocity microphones (see Olson, 1957) are not readily available, are expensive, fragile and large, so they are not commonly used in biological research, though their use in one situation where the source is highly reactive, the recording of *Drosophila* song, is now standard practice. Here, the particle velocity produced by the fly is far louder than the sound pressure, so high quality recordings can be made with minimal sound insulation (see Bennet-Clark, 1971; Bennet-Clark, Leroy & Tsacas, 1980). The microphones can also be used to localize sources of echoes and to measure other reactive conditions. The present design was developed as an alternative to the fragile aluminum-ribbon microphones used previously (Bennet-Clark, 1973) and has the advantages of low cost, small size, robustness and a broad frequency response.

The transducer is an electret membrane open on both sides to the sound wave. The resonant frequency of the electret unit is at the top of the practical frequency range of the microphone (16–17 kHz). Below this, the output is proportional to the driving force, the pressure gradient, so rises 6 dB per octave and leads by 90° in phase compared with the particle velocity (see Michelsen & Nocke, 1974). The microphone has three major components, a pressure gradient transducer, an FET impedance converter in the microphone head and an integrating amplifier to correct the frequency and phase response of the transducer.

The electret unit is Radio Shack type 270-090 (Fig. 1) (Tandy Corporation; products are available world-wide). Retain the metal-coated electret membrane on its supporting ring; the 40 µm thick plastic spacer washer, the perforated fixed electrode and the FET (see Fig. 1).

The membrane is reassembled so as to be open to the sound wave on both sides. Dimensions of a brass housing and PTFE or Delrin (Acetal) insulator are shown in Fig. 2A. Assembly is shown in Fig. 2B. The electret and fixed electrode are separated by the 40 µm spacer washer and the fixed electrode is separated from the housing by the insulator. The edges of the brass housing can then be crimped over to secure the components in position. If the electret is heated, it may discharge.

The FET amplifier should be built close to the transducer. A suitable layout, which incorporates the 1.1 kΩ FET load resistor, is shown in Fig. 2C and the circuit diagram is shown in Fig. 3. In this layout, response varies as the cosine of the angle from the

\* Visiting Professor, Section of Neurobiology and Behavior, Cornell University and Fulbright Travel and Research Scholar, 1982–83.

Key words: Microphone, transducer, displacement.

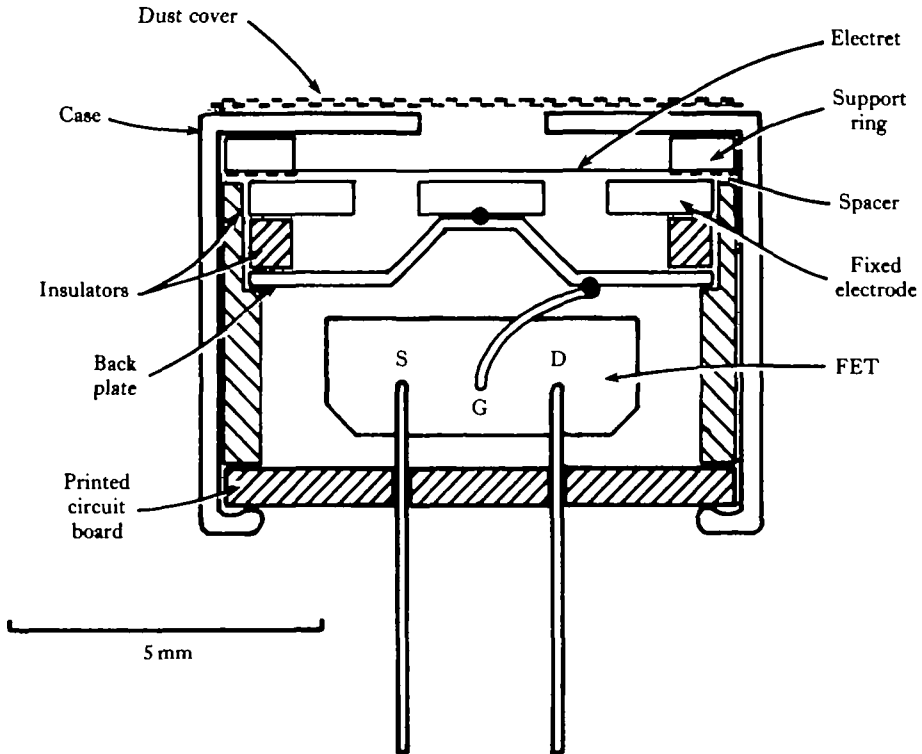

Fig. 1. Diagrammatic sectional view of the Radio Shack 270-090 Electret microphone. The unit is opened by cutting away the base of the case. The components labelled on the right side of the figure should be separated and retained. The spot welds that connect the FET and electrodes are shown as solid circles. Insulators are shown cross-hatched. This diagram shows the FET base connections. S, source; G, gate; D, drain.

normal to the plane of the membrane, and with a null along the plane joining the two support rods. If the electret membrane is placed normal to the axis of the brass case and support rods, the plane of the null is along the plane B—B in Fig. 2C and the maximal response is along the axis of the cylindrical assembly. The microphone head must be shielded from electrostatic fields by a fine copper wire gauze cover. The whole

Fig. 2. Diagrams of the pressure-gradient sensitive microphone transducer and head assembly. (A) Dimensions of the cylindrical brass housing and PTFE or Acetal insulator-support for the fixed electrode. (B) Diagram of the transducer assembly. All solder connections must be made before assembly and crimping over the rear edge of the brass housing. The fixed electrode is insulated from the electret unit by a 40  $\mu\text{m}$  thick spacer and from the housing by the insulator shown in A. (C) One possible design for a microphone head for use in free field situations. The FET and its load resistor are mounted close to the transducer and located by pins inserted into a short length of perforated circuit board glued between the support rods. The head is screened by a copper wire mesh shield attached by screws to the brass base. Insulators are shown cross-hatched and soldered joints as solid circles. The plane of the drawing in B is shown by the line B—B.

Fig. 3. Circuit diagram of the microphone head (shown in Fig. 2C), the integrating amplifier that converts the transducer output to one that is proportional to the particle velocity, and an audio amplifier used to drive headphones. The integrating amplifier and microphone head can be driven from a 9–12 V battery; the voltages shown are those for the complete amplifier. The input attenuator is shown in the 0 dB position. Resistor values are shown in ohms or kilohms, capacitor values are shown in microfarads or nanofarads and the polarity of electrolytic capacitors is shown.

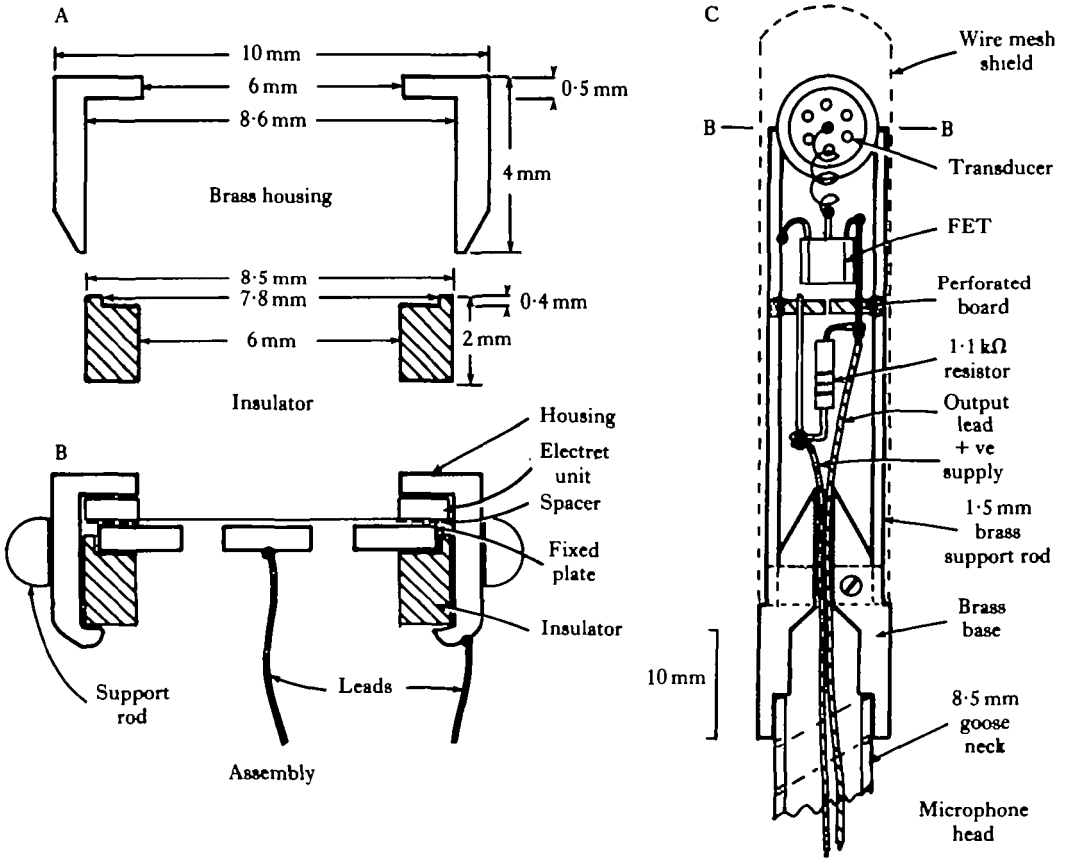

Fig 2A-C

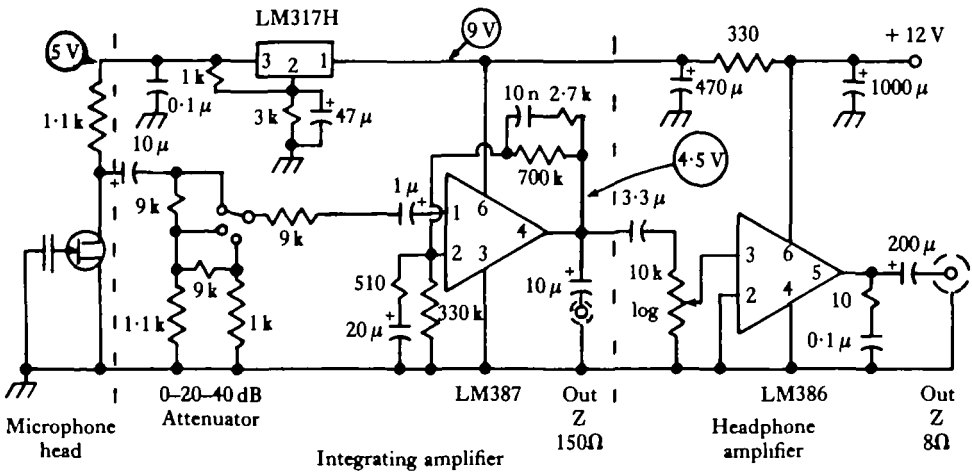

Fig. 3

assembly can be mounted on a gooseneck, an 8.5 mm diameter flexible oilcan spout (Parker Automotive, Plews Division, Minneapolis MN 55416, part 50-932).

For recording *Drosophila* song, an asymmetric transducer placed against one face of a rectangular wire-mesh shield allows the cage containing the flies to be placed close to the transducer (Bennet-Clark *et al.* 1980).

The integrating amplifier uses an IC type LM 387 (Radio Shack 276-1737) (Fig. 3). Integration, phase shifting and the d.c. level are controlled by negative feedback. The amplifier gain is 50 dB at 100 Hz and 18 dB at 5 kHz. Over this range, the phase lead is close to 90°. A suitable power source is a 9 V alkaline battery, the supply to the FET is stabilized to improve low-frequency performance. For recording and monitoring *Drosophila* song, a simple add-on circuit, using a LM 386 (Radio Shack 276-1731) gives ample power to drive headphones (Fig. 3).

The output of the microphones and amplifier described here is flat within 1.5 dB between 100 Hz and 5 kHz with less than 10° phase shift (Fig. 4). Above 5 kHz, because of the dimensions and properties of the electret, the output starts to show irregularities: even so, useful measurements can be made to about 15 kHz. The microphones respond to sounds at 20 Hz, the lower frequency limit of equalization of the amplifier, but this has not been calibrated. The practical lower limit is set by amplifier noise and the leakage resistance of the electret and FET.

The output is 80–120 mV, r.m.s., depending on the electret unit, for a sound particle velocity of  $2.5 \times 10^{-3} \text{ m s}^{-1}$  (in a plane wave, this is the equivalent of 94 dB above  $10^{-12} \text{ W m}^{-2}$ ). Amplifier noise below 100 Hz is equivalent to a 60 dB sound

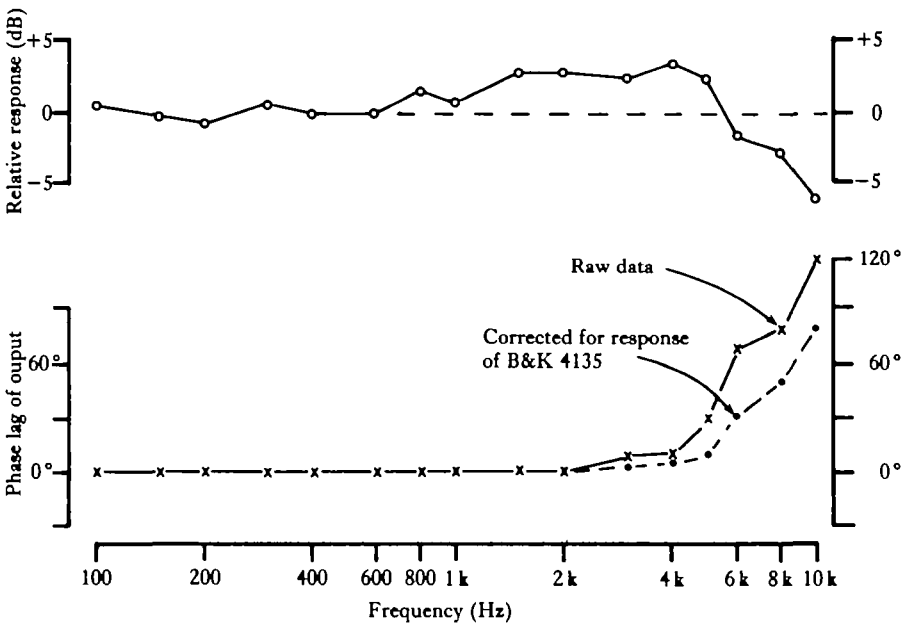

Fig. 4. Amplitude and phase response of the velocity microphone shown in Fig. 2C plotted against frequency. The measurements were made in far field anechoic conditions, comparing the velocity microphone response with that of a Bruel & Kjaer type 4135 pressure sensitive microphone. 0 dB is 115 mV for a sound power of 94 dB above  $10^{-12} \text{ W m}^{-2}$ . The lower phase response curve is corrected for the published phase response curve of the B & K type 4135.

but falls to the equivalent of a 35 dB sound above 1 kHz. The FET head amplifier overloads at about 145 dB at 1 kHz and the integrating amplifier overloads at about 115 dB with the input attenuator at 0 dB. Particle velocity towards the open face of the electret produces a positive-going voltage change in the output. This is the same sense as the pressure response of most Bruel & Kjaer microphones. The response varies closely as the cosine of the angle between the source and the normal to the plane of the electret membrane.

Particle velocity microphones are sensitive to wind, room noise and other low frequency air currents, furthermore, the electret membrane is charged and can collect dust. If an extended low frequency response is not required, the head should be covered with a fine cloth dust shield.

The electret units can be used as small point sources and doublet sources. Measurements made during the course of performance testing showed that such units, driving into a closed volume of 1 cm<sup>3</sup>, could produce sound pressures of at least 100 dB between 2 and 18 kHz and over 90 dB at up to 30 kHz (cf. Kliendienst, Koch & Wohlers, 1981). They should be driven by a high-voltage, high-output-impedance source and operate safely at 100 V r.m.s.

Warm thanks to Cornell University for hospitality during my sabbatical leave. Dr R. R. Hoy gave continued advice, encouragement and support from his grant 5-NR01-NS11630 from NIH.

#### REFERENCES

- BENNET-CLARK, H. C. (1971). Acoustics of insect song. *Nature, Lond.* **234**, 255–259.
- BENNET-CLARK, H. C. (1973). Microphone and preamplifier for recording courtship song of *Drosophila*. *Drosophila Information Services* **49**, 127–128.
- BENNET-CLARK, H. C., LEROY, Y. & TSACAS, L. (1980). Species and sex-specific songs and courtship behaviour in the genus *Zaprionus* (Diptera-Drosophilidae). *Anim. Behav.* **28**, 230–255.
- KLIENDIENST, H.-U., KOCH, U. T. & WOHLERS, D. H. (1981). Analysis of the cricket auditory system by acoustic stimulation using a closed sound field. *J. comp. Physiol.* **141**, 283–296.
- MICHELSSEN, A. & NOCKE, H. (1974). Biophysical aspects of sound communication in insects. *Adv. Insect Physiol.* **10**, 247–296.
- OLSON, H. F. (1957). *Acoustical Engineering*. pp. xix + 718. Princeton: Van Nostrand.

