

Lawrence Berkeley National Laboratory

Recent Work

Title

A PICOSECOND RESOLUTION TIME DIGITIZER FOR LASER RANGING

Permalink

<https://escholarship.org/uc/item/9s3120w7>

Author

Turko, Bojan.

Publication Date

1977-05-01

U 0 0 0 4 8 0 0 0 1 7

UC-37
LBL-6449
c.1

Presented at the IEEE Nuclear Science
Symposium, San Francisco, CA,
October 19 - 21, 1977

A PICOSECOND RESOLUTION TIME
DIGITIZER FOR LASER RANGING

Bojan Turko

May 18, 1977

RECEIVED
LAWRENCE
BERKELEY LABORATORY

FEB 1 1978

LIBRARY AND
DOCUMENTS SECTION

Prepared for the U. S. Department of Energy
under Contract W-7405-ENG-48

For Reference
Not to be taken from this room

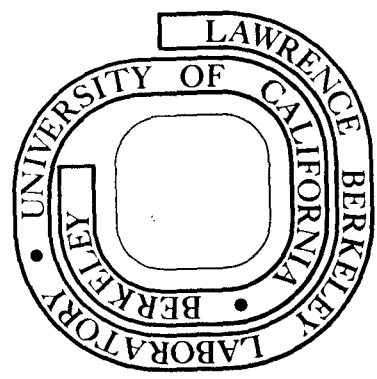

LBL-6449
c.1

DISCLAIMER

This document was prepared as an account of work sponsored by the United States Government. While this document is believed to contain correct information, neither the United States Government nor any agency thereof, nor the Regents of the University of California, nor any of their employees, makes any warranty, express or implied, or assumes any legal responsibility for the accuracy, completeness, or usefulness of any information, apparatus, product, or process disclosed, or represents that its use would not infringe privately owned rights. Reference herein to any specific commercial product, process, or service by its trade name, trademark, manufacturer, or otherwise, does not necessarily constitute or imply its endorsement, recommendation, or favoring by the United States Government or any agency thereof, or the Regents of the University of California. The views and opinions of authors expressed herein do not necessarily state or reflect those of the United States Government or any agency thereof or the Regents of the University of California.

A Picosecond Resolution Time Digitizer
for Laser Ranging

Bojan Turko
Lawrence Berkeley Laboratory
University of California
Berkeley, California 94720

Abstract

The Time Digitizer capable of covering a range of 0.34 sec in 9.76 psec increments is described. The time interval between a pair of start-stop pulses is digitized coarsely in 20 nsec periods by a very accurate 50 MHz reference clock. The residual fractions of a clock period at the start and the stop end of the measured interval are stretched in two interpolators and digitized in 9.76 psec increments. An equivalent digitizing frequency of 102.4 GHz is thus achieved. The digitizer is built in a CAMAC minicrate and communicates via a standard crate controller. It is intended for use in the laser ranging between ground stations and the Laser Geodetic Satellite (LAGEOS). It is shown that the distribution in any two adjacent 9.76 psec channels of a small number of identical test time intervals is essentially binomial. The performance of the digitizer and test results are given.

Introduction

Systems for high resolution pulsed

laser ranging over long distances^{1,2,3} require very accurate and stable time digitizers. The time digitizer is basically a stop watch that measures the time interval between the instant when a powerful narrow laser pulse is fired at a distant target, and the instant the reflected light pulse is received back. The start-stop pulse pair which defines a measured time interval is usually generated by two identical optical receivers. They consist of fast photoelectric devices,^{5,6} (photomultiplier, microchannel plate photomultiplier or an avalanche photodiode) followed by constant fraction discriminators.⁴ The amplitude of the received signal varies greatly due to the atmospheric conditions. The time walk of the discriminator should therefore be very low over a wide range of amplitudes.

The time digitizer described here⁷ covers a range of time intervals from zero to 0.34 sec in 9.76 psec increments (Fig. 1). Its accuracy and stability depends on the quality of the externally applied 50 MHz reference clock. The digitizer also has its internal reference clock which is accurate to 1 part per million and has a thermal stability of $10^{-7}/^{\circ}\text{C}$. This is sufficient for testing and ranging shorter intervals.

The Time Digitizer is built as a modular system in a CAMAC minicrate and can communicate with the computer through any standard crate controller. The digitized intervals are available in 35-bit binary words which can be transferred to the computer in 3 bytes.

A stand-alone decimal display module is also included in the system. Each time interval is converted simultaneously into a decimal number as well and displayed in 11 decades. This makes an easier checkup and monitoring of the whole ranging system.

A built-in calibrator, incorporated in the clock module, can be used both for the checking the Time Digitizer and as a precise marker generator when the Time Digitizer is used for the measurement of frequency and phase noise distribution of external frequency sources. The calibrator is basically a presettable digital frequency divider. The measured frequency is reduced in the calibrator into longer time intervals, which are then measured randomly by the Time Digitizer. Picosecond phase shifts and phase noise distributions are readily measured.

The Time Digitizer is to be used, by the NASA (National Aeronautics and Space Administration), for the ranging between ground stations and the Laser Geodetic Satellite (LAGEOS), that was put into the orbit in 1976. The objective is some geophysical measurements to be performed by NASA to monitor the drift of the continental plates for possible earthquake predictions.

Operation Principle

Each event to be measured is the time interval between the pulses applied to the start and the stop input of the Time Digitizer. The pulses are standard fast NIM signals. The beginning and the end of the time interval are defined as points in time when the start and the stop input signals, terminated on a 50 ohm load, reach a level of 300 mV. A fast tunnel diode discriminator is fired at this level in each input circuit. For picosecond time resolution measurements, it is essential that the shape and amplitude of the start and stop signals does not change from event to event, and the level of any noise superimposed upon them be kept at a minimum.

The principle of the operation of the Time Digitizer can be best described by the simplified timing diagram in Fig. 2. T is the interval to be measured and is generally uncorrelated to a free running clock of 50 MHz. T can be split into three fractions T_1 , T_{12} and T_2 so that

$$T = T_1 + T_{12} - T_2 \quad (1)$$

T_1 is the fraction between the start pulse and the second following clock pulse and T_2 is the fraction between the stop pulse

and the second clock pulse afterwards. T_{12} is thus synchronized with the clock and can be easily digitized by counting a train of N_{12} clock pulses in the main scaler, since $T_{12} = N_{12}T_0$ and $T_0 = 1/f_0 = 20$ nsec.

T_1 and T_2 are fed into two identical time stretcher modules called Start Interpolator and Stop Interpolator. The Start Interpolator generates a gate pulse kT_1 wide that enables a start scaler to count a train of N_1 clock pulses. Note that the beginning of the start gate is synchronized with the clock; therefore, only the last clock pulse in the train is ambiguous. Thus $kT_1 = N_1T_0$.

Similarly, the Stop Interpolator generates a gating pulse kT_2 wide, and N_2 clock pulses are counted in the stop scaler, resulting in $kT_2 = N_2T_0$. Eq. (1) thus becomes.

$$T/T_0 = N_1/k + N_{12} - N_2/k \quad (2)$$

where T is the measured time interval, T_0 is clock frequency period and N_1 , N_{12} and N_2 are the reading of the scalars. A binary interpolation constant $k = 2^{11} = 2048$ has been selected. Each count in N_1 and N_2 is therefore worth $T_0/k = 20 \cdot 10^{-9} / 2048 = 9.76$ psec.

The effect of the interpolation is the same as though the time interval T had been directly digitized by a reference clock having a frequency of $f_{eq} = kf_0 = 102.4$ GHz.

The error ΔT in measuring T can be derived from Eq. (2).

$$\Delta T \approx T_0/k [|\Delta N_1 - \Delta N_2| + T |\Delta f_0/f_0|] \quad (3)$$

ΔN_1 and ΔN_2 are interpolator errors caused mostly by thermal drifts, and $\Delta f_0/f_0$ is the clock frequency change. Identical interpolators provide a very good tracking. An average drift of ± 2.3 psec/ $^{\circ}$ C in a temperature range between 0 and 40 $^{\circ}$ C was measured. No attempt to match interpolators for even better tracking was made.

The second term in (3) depends only upon the reference clock. Extremely stable and noise free clock is needed if the full resolution at very long T 's is required.

Time digitizers employing similar interpolation techniques have been used mostly in time of flight measurements and reported in Refs. (10), (11) and (12) and some others in Refs (8) and (9).

System Description

The Time Digitizer is organized as a modular system. It consists of three mostly analog modules and three digital modules. In this manner the crosstalk through filtering and shielding is made negligible and the number of interconnections minimized. The

digitizer was designed to be a part of the PDP-11/40-based data processing system. In order to minimize the interface and packaging problems, a Standard Engineering Co. CAMAC mini-crate and an ORTEC, Inc. DC011 Crate Controller are used.

A block diagram showing the modules and their basic functions and interconnections is given in Fig. 3. Briefly, they are:

Clock and Calibrator Module. First section, the clock, comprises an internal reference frequency standard and provides properly shaped and timed clock pulses to the interpolators and the logic unit. A clock output is available for frequency monitoring or for driving the calibrator in order to generate precise phase locked start and stop pulses for testing the digitizer. The clock module can be switched to a more accurate external frequency standard of 50 MHz.

The calibrator divides any input frequency up to 150 MHz into ten selectable ranges, generating thus precise, low phase noise time markers for calibration and testing of the digitizer.

Start Interpolator and Stop Interpolator. There are two identical time-to-time converters that stretch 2048 times the time fractions T_1 and T_2 at the beginning and the end of the measured interval T (Fig. 2). The stretched fractions are separately digitized in the logic module.

When the digitizer is ready, the logic unit keeps the start input enabled and the stop input disabled. Only after a start input pulse has been accepted, the stop input will be enabled, but only after a preselected enable time had elapsed. Both the start and the stop input can be gated to prevent false starts or stops. Either coincidence or anticoincidence mode can be selected.

If the stop pulse is not accepted within one of the preselected time ranges, the over-range condition occurs which enables the digitizer for a new start.

Logic Unit. It contains the logic for the conversion of the gate signals from the interpolators into pulse trains which are counted and temporarily stored in the start, stop and main scaler. After the conversion is completed, adding and subtraction takes place according to Eq. (2). The result is then shifted into a 35-bit buffer register and the digitizer cleared for another event. A ready signal requesting a service is sent to the computer. Until cleared, the buffer register data is displayed by a LED array. The module also has a CAMAC logic section for communication with the crate controller. The front panel has the controls and indicators for full manual operation of the digitizer and the selection of the time and stop enable ranges.

Decimal Display. In order to save on conversion time, a combination of parallel-series binary-to-decimal conversion technique was used. The measured interval is displayed in 11 decades as soon as the conversion is

over. In manual operation two successive events can be displayed simultaneously: the first one in the Logic Unit and the second one in the Decimal Display module.

Distribution of Measured Intervals

When a single time interval is digitized by a free running clock, a maximum error of two clock pulse periods results. Therefore, the number that defines the interval by counting the clock pulses, can be either even or odd. If a total of n time intervals of the same width are measured and recorded, x and $(n-x)$ of them will be stored in two adjacent channels of the memory. An ideal case of noiseless time-to-digital conversion is considered. The n events will be then statistically distributed only in two adjacent channels.

This method gives the possibility of resolving the measured time interval to a fraction of a clock pulse. The closer that fraction is to a full clock period, the greater the probability to store that event into only one channel. The distribution function is linear, resulting in a characteristic triangular "channel profile." If a particular memory channel counted x out of a large number of n measured time intervals T (and the preceding lower channel counted $n-x$ ones), the measured interval is actually shorter by a fraction t of a channel

$$t = \frac{x}{n} \frac{T}{k} \quad (4)$$

where $T_0/k = 9.76$ psec is the period of the equivalent clock frequency.

In those time-to-digital converters where the beginning of the measured interval is synchronous with the clock, the end fraction of that interval which is smaller than one clock pulse, is being counted as if it were a full clock pulse wide. The resolution of measurement by digitizing many equally wide time intervals cannot be thus increased beyond one clock pulse width. Thus a rectangular channel distribution (or "channel profile") is characteristic for that kind of time-to-digital converters.

In some laser ranging measurements a total of n available events is statistically not large enough to use Eq. (4). Relative frequency x/n gives then only an approximate size of t . An estimate how accurate t can be determined by n independent measurements of an interval T is given by the binomial law of probability:¹³

$$B(x) = \frac{n!}{x! (n-x)!} p^x (1-p)^{n-x} \quad (5)$$

where x and $n-x$ are the number of events stored in two adjacent channels of the memory and the constant probability $p = tk/T_0$. From (5) the corresponding distribution function can be obtained:

$$F(x) = B(0) + B(1) + B(2) + \dots + B(x). \quad (6)$$

Eq. (5) is illustrated in Fig. 4 for a total of $n=20$ events. The probability is maximum when $p = x/n$. It is lowest for $p=0.5$; i.e., when t is one half of a channel. In Fig. 5 the distribution curves give the percentage of how accurately $t = pT_0/k$ can be determined when the

frequency x/n of a total of $n=20$ events has been recorded.

As the number of measurements n increases, the maximum probability increases (Fig. 6). For a large n and p the computation of $B(x)$ becomes difficult. Eq. 5 can be replaced by the Laplace approximation

$$B(x) = (2\pi)^{-1/2} \sigma^{-1} e^{-\delta^2/2\sigma^2} \quad (7)$$

where $\sigma = [np(1-p)]^{1/2}$ and $\delta = x - np$. The distribution is then obtained by the integration of Eq. (7)

$$F(x) = (2\pi)^{-1/2} \int_0^x e^{-u^2/2} du \quad (8)$$

Experimental Results

Presence of noise in the interpolators and the reference clock oscillator results in distribution of measured time intervals over more than two channels. In order to separate the interpolator and the clock noise contributions, a constant time interval was generated by a 140 nsec delay line, driven by the Time Digitizer's Calibrator. By inserting a variable delay line, two distributions were generated (Fig. 7). In the first one the delay was adjusted to count equally into two adjacent channels. The time measured is therefore 14,912.5 channels. The second delay was adjusted so as to count only in the channel 14,926. Only about 4% of the counts fall in the two adjacent channels.

In Fig. 8 the same time intervals were measured except that an external pulse source was used. The distributions were broadened by the external source interference, but still a resolution of better than one channel was obtained.

Three groups of about 3 msec wide time intervals were generated by dividing the frequency of a very accurate external low noise crystal oscillator. Separated by a small additional delay, the resulting distributions are shown in Fig. 9. The distributions include the composite phase noise of both the measured and the internal clock oscillator. The positions of the peaks still give time resolutions better than one channel.

An external synthesized frequency standard of 50 MHz was used in generating 2.6 msec time intervals. The spectrum in Fig. 10a shows a -40db 40 MHz component that caused a 30 psec spaced double peak in the distribution (Fig. 10b). The double peak disappeared when a narrow band filter reduced the 40 MHz component to below -60db (Fig. 10c).

A very low phase noise is therefore required, in addition to the high accuracy and stability, of the external frequency standard intended for a very high resolution measurements of wide time intervals.

Conclusions

The results of the tests performed so far on the Time Digitizer have indicated that a new generation of digitizer with greatly improved resolution can be designed. Using an improved interpolation technique, the resolution may be increased to about 0.1 psec/channel. This will require, however, a better thermal stability. The use of the same interpolator for both the start and the stop inputs will eliminate some tracking difficulties. Also the conversion deadtime can be reduced by employing "tandem" interpolation techniques.

The present state of art of other components of the optical receiver such as photodetectors and pulse

positioning discriminators is not yet adequate to justify development of such a digitizer for ranging applications.

However, it can be used now for more accurate ranging at shorter distances where much larger return signals are expected and less sensitive but faster photodetectors can be used.

Another completely new application of this kind of digitizer is fast measurements of phase differences and phase difference structures of various high frequency repetitive waveforms down into femtosecond range. Also, phase noise distributions of high quality harmonic and other frequency sources can be measured.

Acknowledgments

This work was performed as part of the program of the Electronics Research and Development group of the Lawrence Berkeley Laboratory, University of California, Berkeley, and was supported by the National Aeronautics and Space Administration-Goddard Space Flight Center, Greenbelt, Maryland, under Contract NDPR No. S-55772A, and the Energy Research and Development Administration under Contract No. W-7405 ENG-48.

References

1. T. E. McGunigal, W. J. Carrion, L. O. Caudill, C. R. Grant, T. S. Johnson, D. A. Premo, P. L. Spadin, G. C. Winston, Statellite Laser Ranging Work at the Goddard Space Flight Center. WESCON Technical Papers, Vol. 19, Section 9/2, pp. 1-8, 1975.
2. M. W. Fitzmaurice, P. O. Minott, W. D. Kahn, Development and Testing of a Spaceborne Laser Ranging System Engineering Model, Goddard Space Flight Center X-Document, X-723-75-307, November 1975.
3. S. F. Bearse, Accurate Measurements Key to Forecasting Earthquakes, Microwaves, Vol. 15, No. 6, pp. 10, 14, May 1976.
4. Branko Leskovar, C. C. Lo, Optical Timing Receiver for the NASA Laser Ranging System, Part I: Constant Fraction Discriminator, Lawrence Berkeley Laboratory Report, LBL-4219, August 14, 1975.
5. C. C. Lo, B. Leskovar, Evaluation of the AmpereX 56 TVP Photomultiplier, Lawrence Berkeley Laboratory Report, LBL-5328, July 7, 1976.
6. C. C. Lo, B. Leskovar, Performance Studies of Varian VPM-154D.6D and VPM-154A/1.6L Static Crossed Field Photomultipliers, Lawrence Berkeley Laboratory Report, LBL-6480, June 17, 1977.
7. Branko Leskovar, Bojan Turko, Optical Timing Receiver for the NASA Laser Ranging System, Part II: High Precision Time Interval Digitizer, Lawrence Berkeley Laboratory Report, LBL-6133, February 25, 1977.
8. D. F. Porat, Review of Sub-Nanosecond Time-Interval Measurements, IEEE Transactions of Nuclear Science, Vol. NS-20, No. 5, pp. 36-51, October 1973.
9. J. P. Argyle, P. E. Dooley, G. Huxtable, A Fast Multi-Event Time Digitizer in a CAMAC Module, Proceedings 2nd Inspra Nuclear Electronics Symposium, pp. 421-428, Commission of the European Communities, EURATOM, Luxembourg, June 1975.

10. R. Nutt, Digital Time Intervals Meter, The Review of Scientific Instruments, Vol. 39, No. 3, pp. 1342-1345, September 1968.
11. B. Turko, Multiple Stop Clock for Neutron Time-of-Flight Measurements, Bulletin of the American Physical Society, Series II, Vol. 16, No. 1, pp. 56-57, January 1971.
12. B. Turko, TDC 100 Time Digitizer, Instruction Manual, EG&G/ORTEC, Inc., November 1970.
13. I. S. Sokolnikoff, R. M. Redheffer, Mathematics of Physics and Modern Engineering, McGraw-Hill, 1958.

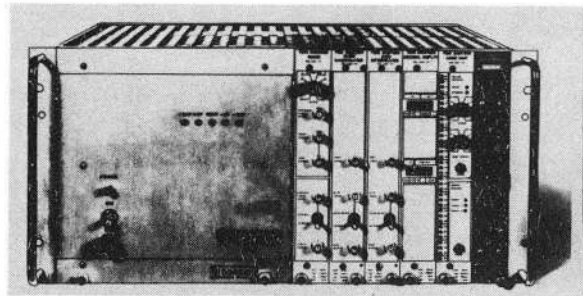
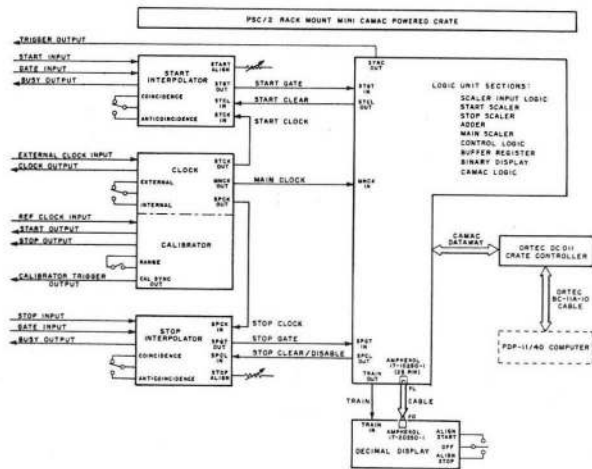
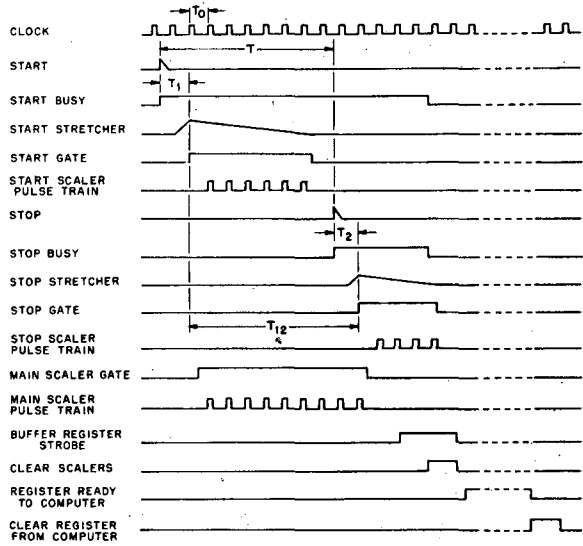

Fig. 1 Time Digitizer front view.



XBL 773-7890

Fig. 3 Block diagram.



XBL 773-7891

Fig. 2 General timing diagram.

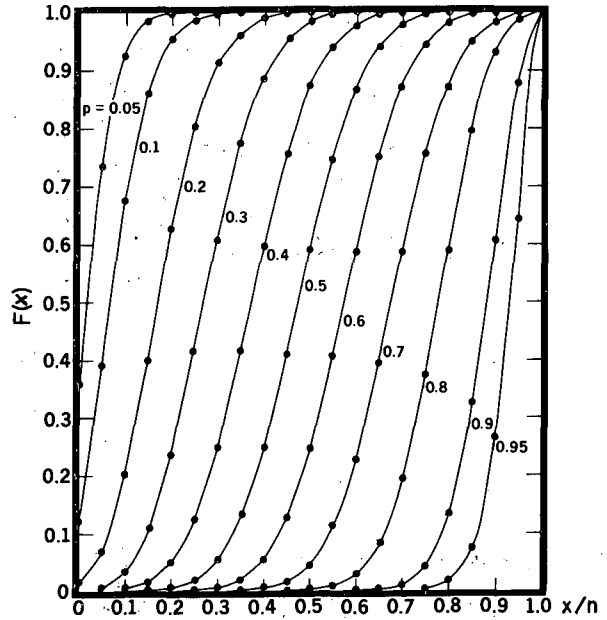

XBL 7710-10041

Fig. 5 Distribution $F(x)$ vs. relative frequency x/n for $n=20$ events and $p=tk/t_0$.

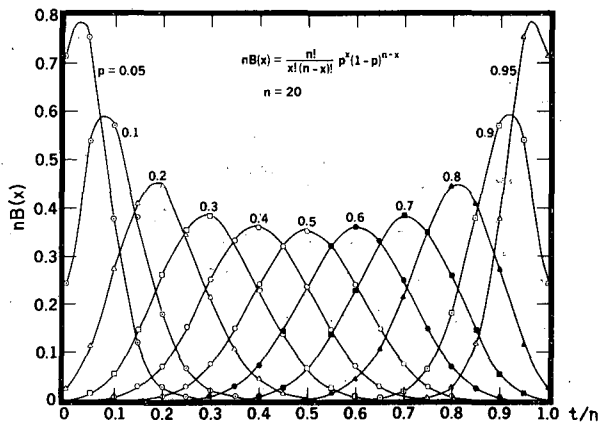

XBL 7710-10040

Fig. 4 Probability $nB(x)$ vs. relative frequency x/n for $n=20$ events and $p=tk/t_0$.

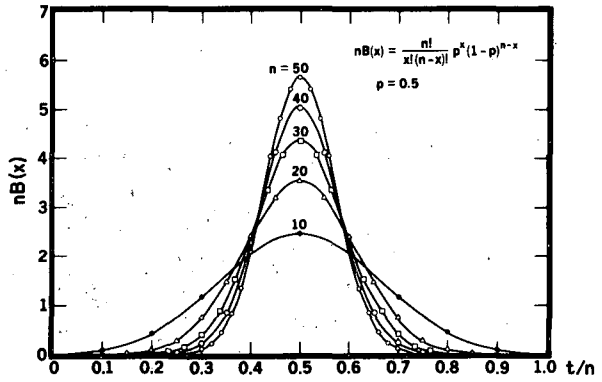

XBL 7710-10042

Fig. 6 Probability $nB(x)$ vs. relative frequency x/n and n for $p=tk/T_0=0.5$.

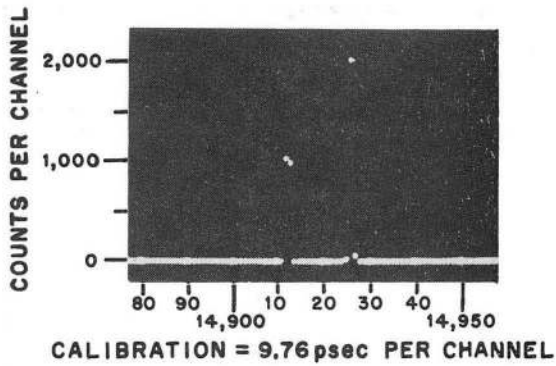

Fig. 7 Measurement of two 140 nsec time intervals generated by a delay line and Calibrator.

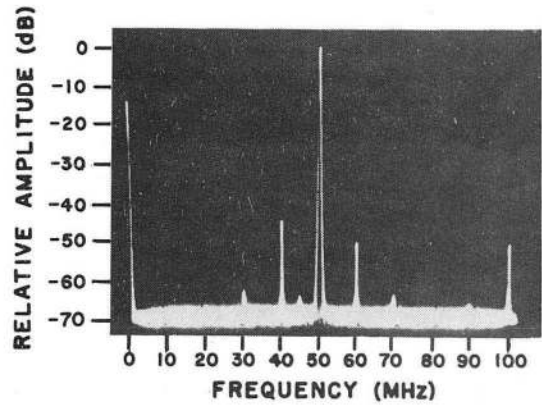

Fig. 10a Frequency spectrum of an external 50MHz clock.

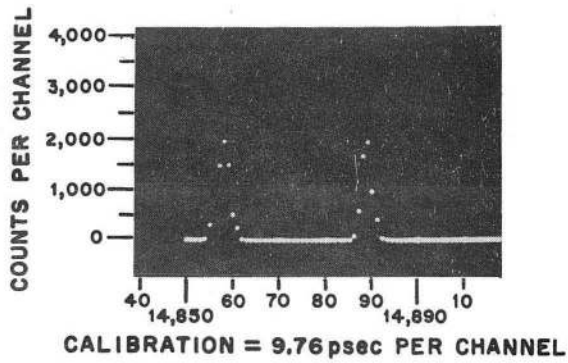

Fig. 8 Measurement of two 140 nsec time intervals generated by a delay line and external pulse generator.

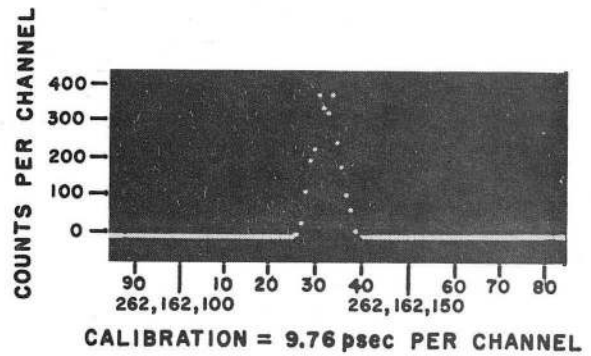

Fig. 10b Phase noise distribution of 2.6 msec time intervals shows double peaks due to a 40MHz component in the spectrum.

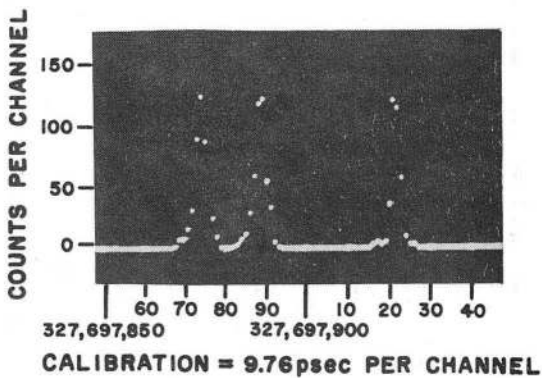

Fig. 9 Composite phase noise of a 5MHz external oscillator and internal clock at 3 msec time intervals.

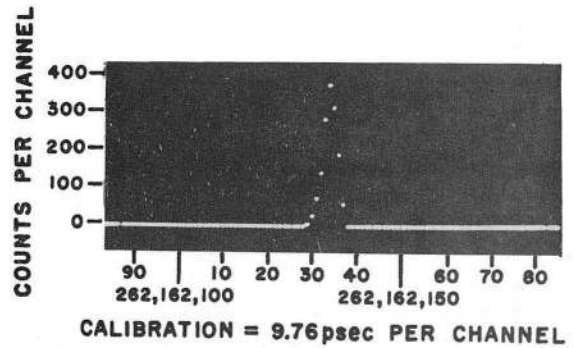

Fig. 10c Phase noise distribution after elimination of the 40 MHz line.

This report was done with support from the Department of Energy. Any conclusions or opinions expressed in this report represent solely those of the author(s) and not necessarily those of The Regents of the University of California, the Lawrence Berkeley Laboratory or the Department of Energy.

TECHNICAL INFORMATION DEPARTMENT
LAWRENCE BERKELEY LABORATORY
UNIVERSITY OF CALIFORNIA
BERKELEY, CALIFORNIA 94720