

2002

## A potential nutraceutical from *Leuconostoc mesenteroides* B-742 (ATCC 13146); production and properties

Chang-Ho Chung

*Louisiana State University and Agricultural and Mechanical College*

Follow this and additional works at: [https://digitalcommons.lsu.edu/gradschool\\_dissertations](https://digitalcommons.lsu.edu/gradschool_dissertations)



Part of the [Life Sciences Commons](#)

---

### Recommended Citation

Chung, Chang-Ho, "A potential nutraceutical from *Leuconostoc mesenteroides* B-742 (ATCC 13146); production and properties" (2002). *LSU Doctoral Dissertations*. 464.  
[https://digitalcommons.lsu.edu/gradschool\\_dissertations/464](https://digitalcommons.lsu.edu/gradschool_dissertations/464)

This Dissertation is brought to you for free and open access by the Graduate School at LSU Digital Commons. It has been accepted for inclusion in LSU Doctoral Dissertations by an authorized graduate school editor of LSU Digital Commons. For more information, please contact [gradetd@lsu.edu](mailto:gradetd@lsu.edu).

A POTENTIAL NUTRACEUTICAL FROM *LEUCONOSTOC MESENEROIDES* B-742  
(ATCC 13146); PRODUCTION AND PROPERTIES

A Dissertation

Submitted to The Graduate Faculty of the  
Louisiana State University and  
Agricultural and Mechanical College  
in partial fulfillment of the  
requirements for the degree of  
Doctor of Philosophy

in

The Department of Food Science

by  
Chang-Ho Chung  
B. Sc., Sejong University, 1995  
M.S., Sejong University, 1997  
May 2002

## ACKNOWLEDGMENTS

I would like to express my sincere appreciation to my major advisor, Dr. Donal F. Day, for invaluable guidance, encouragement, and inspiration that he provided throughout the course of this study and the preparation of this dissertation.

Special thanks are extended to Drs. J. Samuel Godber and Joan M. King in the Department of Food Science, Gregg S. Pettis in the Department of Biological Sciences and Mark L. McLaughlin in the Department of Chemistry for their kind service as members of advisory and examining committee. Appreciation is also extended to all staffs and professors in Audubon Sugar Institute for providing all resources necessary to conduct this research. I wish to express my appreciation to Duwoon Kim and Giovanna De Queiroz for their kind suggestion and help for the research. Thanks are extended to fellow graduate students and to the faculty of the Department of Food Science for their encouragement. I would also like to thank Seungho Cho for his wonderful friendship and Dr. Kyu Hang Kyung for his constructive suggestions.

I would like to dedicate this work with my deepest appreciation to my mother, Ki-Rye Kim, and my father, Ji-Suk, as well as my family. I would like to thank my wife, Heeyoung Kim, for her love, prayers, encouragement and support.

Studying as a foreign person in the United States gave me a lot of unforgettable experiences during my studies. Feeling sometimes depressed and sometimes happy..... After four years, I am seeing fruits of my labor. Lastly, I really thank God for allowing me to participate in these experiences and to meet such wonderful friends. I will cherish these precious memories with our expecting daughter, Ha-yeon, with a smile.

## TABLE OF CONTENTS

	Page
ACKNOWLEDGMENTS .....	ii
LIST OF TABLES .....	v
LIST OF FIGURES .....	vi
ABSTRACT .....	viii
INTRODUCTION .....	1
LITERATURE REVIEW .....	4
1. Prospective for Functional Foods .....	4
2. Probiotics and Prebiotics as Functional Foods .....	6
3. Oligosaccharides as Prebiotics .....	10
3.1 Types .....	11
3.2 Beneficial Effects of Oligosaccharides .....	15
4. Enzyme and Mechanism of Synthesis of $\alpha$ -Glucooligosaccharides .....	18
4.1 Glucansucrases (Dextransucrases) .....	18
4.1.1 Structure and Function .....	19
4.1.2 Mechanism of Action .....	22
4.1.2.1 Glucan (Dextran) Synthesis.....	22
4.1.2.2 Oligosaccharides Synthesis (Acceptor Reaction).....	26
4.1.2.3 Branch Formation .....	28
5. <i>Leuconostoc mesenteroides</i> ATCC 13146 and Its Dextransucrase .....	29
5.1 Enzyme .....	29
5.2 Oligosaccharides by Acceptor Reaction .....	30
5.3 Mannitol as Byproduct .....	34
6. Starch Digestion and Intestinal Microflora .....	37
7. Potential Applications .....	38
MATERIALS METHODS.....	41
1. Organisms, Culture Medium, and Inoculum Preparation .....	41
2. Preparation of Oligosaccharide .....	42
3. Analytical Methods .....	42
4. Oligosaccharide Utilization by Selected Microorganisms .....	45
RESULTS.....	47
1. Oligosaccharide Production .....	47
2. Glucooligosaccharides as Microbial Growth Modifiers .....	56
3. Possible Prebiotic Mechanism in Intestines .....	68
DISCUSSION .....	76

REFERENCES .....	84
APPENDIX A: <sup>13</sup> C N.M.R. DATA .....	103
APPENDIX B: STRUCTURES OF OLIGOSACCHARIDES.....	104
VITA .....	105

## LIST OF TABLES

1. Several foods known as functional foods .....	5
2. Postulated beneficial health effects of probiotics and prebiotics .....	7
3. Linkages in different dextrans as obtained by methylation analysis .....	23
4. Product yields and process for production of glucooligosaccharide .....	57
5. Growth comparison on glucooligosaccharide preparations .....	60
6. Growth comparison of chicken ceca bacteria on the glucooligosaccharide preparations .....	66

## LIST OF FIGURES

1. General schematic diagram of a glucansucrase .....	20
2. Various mechanisms for the synthesis $\alpha$ -1,6 glucan by <i>L. mesenteroides</i> B- 512F (ATCC 10830) .....	25
3. Schematic representation of carbon flow by <i>Leuconostoc mesenteroides</i> ATCC 13146 during metabolism .....	31
4. Schematic representation of carbon and energy flows through the central metabolic pathways of <i>L. mesenteroides</i> .....	36
5. Glucooligosaccharide production by <i>L. mesenteroides</i> ATCC 13146 from sucrose (10 % w/v) and maltose (5% w/v) as a function of time .....	48
6. TLC of glucooligosaccharide production as a function of time .....	49
7. Rf values for oligosaccharides, taken from a TLC plates based on linkages .....	51
8. Profiles of mannitol/oligosaccharide separation on different cation resins .....	52
9. HPLC chromatogram of the peaks fractionated by Ca <sup>2+</sup> cation resin columns .....	53
10. Flow chart for glucooligosaccharide production .....	54
11. HPLC chromatogram from oligosaccharide processes .....	55
12. TLC of branched $\alpha$ -glucooligosaccharides of <i>L. mesenteroides</i> (ATCC 13146) ....	58
13. <sup>13</sup> C NMR of <i>Leuconostoc</i> glucooligosaccharides.....	59
14. TLC of anaerobic growth of <i>E. coli</i> B (ATCC 23226) on 0.5% glucooligosaccharide preparations .....	62
15. TLC of anaerobic growth of <i>Salmonella typhimurium</i> (ATCC 14028) on 0.5% glucooligosaccharide preparation .....	63
16. TLC of anaerobic growth of <i>Bifidobacterium longum</i> (ATCC 15708) on 0.5% glucooligosaccharide preparations .....	64
17. Anaerobic growth of mixed cultures of <i>S. typhimurium</i> and <i>L. johnsonii</i> (ATCC 33200) glucooligosaccharide preparation at 37°C .....	65
18. Anaerobic growth of mixed cultures of <i>S. typhimurium</i> and ceca bacteria on the glucooligosaccharide preparation at 37°C .....	67

19. TLC of anaerobic growth of chicken ceca bacterium # 5 on 0.5% glucooligosaccharide preparations .....	69
20. $\alpha$ -Glucosidase (maltase) activity inhibition with increasing concentrations of <i>Leuconostoc</i> glucooligosaccharides .....	70
21. Double reciprocal plot of $\alpha$ -glucosidase (maltase) activity inhibition as the concentration of the glucooligosaccharides increased .....	71
22. $\alpha$ -Glucosidase (maltase) activity in the presence of different concentrations of panose (branched; $\alpha$ -1,4 and $\alpha$ -1,6) and isomaltotriose (linear; two $\alpha$ -1,6).....	72
23. Double reciprocal plot of $\alpha$ -glucosidase (maltase) activity change as the concentration of panose or isomaltotriose increased.....	73
24. Anaerobic growth of <i>S. typhimurium</i> and <i>B. longum</i> on different combinations of panose and maltooligosaccharides (d.p. 4 – 10) at 37°C.....	74
25. Comparison of growth rates in log phase between <i>S. typhimurium</i> and <i>B. longum</i> at different concentrations of panose and maltooligosaccharides .....	75



## ABSTRACT

There is an emerging market for functional oligosaccharides for use in foods. Currently, technology for the production of oligosaccharides is limited to extraction from plant sources, acid or enzymatic hydrolysis of polysaccharides or synthesis by transglycosylation reactions. Oligosaccharides also can be produced using a *Leuconostoc* fermentation and restricting the polymer size by the addition of maltose. Maltose limits the dextransucrase reaction, yielding high concentrations of  $\alpha$ -glucooligosaccharides. Branched oligomers produced by this process were found to be readily catabolized by bifidobacteria and lactobacillus but were not readily utilized by either *Salmonella* sp., or *E. coli*, pointing toward their use in intestinal microflora modification. Branched  $\alpha$ -glucooligosaccharides were non-competitive inhibitors of  $\alpha$ -glucosidase (maltase), an enzyme required for starch or maltodextrin utilization.

## INTRODUCTION

Use of functional food products, especially those containing live cultures of *Bifidobacterium* and *Lactobacillus*, called probiotics, has increased (Roberfroid, 2000). These bacteria reside naturally in the large intestine. Although the mechanism of action is not fully understood, the available evidence indicates ingestion of probiotic bacteria may actually improve several of the host's physiological processes. These include the alleviation of lactose intolerance, immune enhancement, and a reduction in mutagenic enzymes such as  $\beta$ -glucuronidase, nitroreductase, and choloylglycine hydrolase (Collins and Gibson, 1999; Roos and Katan, 2000). To be effective, dietary probiotics must reach the large intestine. Barriers in the human body, which include acidic pH in the stomach, degradative enzymes and bile in the small intestine, often prohibit effective ingestion of probiotics. Researchers have attempted to isolate bacterial strains resistant to bile and acidic conditions (Chung *et al.*, 1999; Kaplan and Hutkins, 2000) and have also tried to develop microencapsulation technology that would protect these bacteria on their way to a target location (Crittenden *et al.*, 2001).

It is believed that the ability of these probiotics to catabolize oligosaccharides (two to ten monosaccharide units linked with glycosidic bonds) is a key factor in their bestowing beneficial health effects. Certain carbohydrates, called prebiotics, can escape metabolism and adsorption in the small intestine and ultimately influence the composition of microflora in the large intestine (Loo *et al.*, 1999). Prebiotics are generally non-digestible by humans. Oligosaccharides are used widely in foods such as soft drinks, cookies, cereals, candies, and dairy products. Other applications for oligosaccharides such as an anti-cariogenic agent (Ooshima *et al.*, 1983) or a low sweetness humectant (Yoo *et al.*, 1995) have been explored.

Antibiotic resistance among known pathogens such as *Salmonella* and *E. coli* is expanding due to the wide use of these compounds in areas ranging from medicine to animal feed. The pressure to remove antibiotics from animal feeds has left a need for safe alternatives that can reduce levels of these bacteria in animals (Hileman, 2001; Hofacre *et al.*, 2000). Selected fructooligosaccharides and glucooligosaccharides have shown potential as alternatives to antibiotics (Monsan and Paul, 1995). Those oligosaccharides with the greatest antibacterial effects are either fructans or branched glucans (Anonymous, 1999; Loo *et al.*, 1999; Valette *et al.*, 1993).

Prebiotic oligosaccharides are currently produced either by extraction from plant sources, acid or enzymatic hydrolysis of polysaccharides or enzymatic synthesis by transglycosylation reactions (Chesson, 1993; Morgan *et al.*, 1992). Glucooligosaccharides can be produced by restricting polymer size during the fermentation process (Koepsell *et al.*, 1952). Dextranase (EC 2.4.1.5), an enzyme usually produced by species of *Leuconostoc* and *Streptococcus*, catalyzes the synthesis of high molecular weight glucans (dextrans).

In the presence of sucrose, dextranase produces a linear backbone of D-glucopyranosyl units, linked  $\alpha$ -1,6 that can have variable amounts of  $\alpha$ -1,2,  $\alpha$ -1,3, or  $\alpha$ -1,4-branched side chains. The actual degree of branching depends on the specific strain of microorganism (Robyt, 1986). When an efficient chain ending acceptor, such as maltose or isomaltose, is present in high concentration, dextranase will catalyze the synthesis of  $\alpha$ -glucooligosaccharides (Koepsell *et al.*, 1952; Robyt and Eklund, 1983). This process applied to a *L. mesenteroides* ATCC 13146 fermentation produces branched glucooligosaccharides that can function as prebiotics.

The goals of the present research are to develop an industrial production method for oligosaccharides using a *L. mesenteroides* ATCC 13146 fermentation by acceptor reaction and to show potential of these oligosaccharides as prebiotics.

## LITERATURE REVIEW

### 1. Prospective for Functional Foods

The term functional foods was first introduced in Japan in the mid- 1980s and refers either to processed foods containing ingredients that aid specific bodily functions in addition to being nutritious, or food ingredients that provide health benefits beyond that expected from its components (Hasler 1996, Table 1). Physiologically functional foods have been developed in Japan during the past ten years. These foods are now known as *Foods for Specified Health Use* (FOSHU) and are regulated by the Japanese government, bearing its seal of approval. About 100 such products are licensed in Japan as FOSHU foods (Hasler 1998). Their market in Japan reached \$4.5 billion in 1995 and the annual growth rate was 8.0%. In the United States, functional foods are not categorized by law, though the Institute of Medicine's Food and Nutrition Board (IOM/NAS, 1994) gave a definition to functional foods as "any food or food ingredient that may provide a health benefit beyond the traditional nutrients it contains." According to an estimation by Decision Resources, Inc. (Waltham, 1998), the current US market for functional foods is calculated at \$28.9 billion. It is also one of the fastest growing segments of the food industry (Tomomatsu, 1994). A number of factors have contributed to the rapid development of functional foods. They include scientific advances supporting the vital role of diet in overall health and well-being, consumer demand, the increased role of food and food ingredients for self-medication and disease prevention, a changing regulatory environment, and technical advances in the food industry, to name a few (Hasler, 1996).

Table 1. Several foods known as functional foods

Source Basis	Foods / ingredients	Proposed Health claims
Plants	Oats / soluble fiber $\beta$ -glucan	Reductions in total and low density lipoprotein (LDL) cholesterol
	Soy / isoflavons	Increasing bone minerals and density
	Protease inhibitors	Cholesterol-lowering effect
	Phytic acid	Reduction of risk of estrogen-dependent cancer
	Phytosterols, Saponins	
	Flaxseed / $\omega$ -3 fatty acids	Reduction of risk of estrogen-dependent cancer Reductions in total and low density lipoprotein
	Tomatoes / lycopene	Reduction of risk of cancer
	Garlic / sulfur- containing compounds	Chemo-prevention of cancer Antibiotic, Antihypertensive Cholesterol-lowering effects
	Broccoli and other Cruciferous Vegetables / isothiocyanates, indoles	Reduction of the risk breast cancer
	Citrus Fruits / limonoids	Anticancer activity
	Cranberry / unidentified polymeric compounds	Reduction of urinary tract infections
	Animals	Tea / catechins
Wine and Grapes / phenolics		Reduction of cardiovascular disease
Fish / $\omega$ -3 fatty acids		Reduction of cardiovascular disease
Dairy Products / lactic acid bacteria		Improving intestinal microbial balance Source of calcium and an essential nutrients
	Oligosaccharides	Reduction of colon cancer
	Beef / conjugated linoleic acid	Suppressing forestomach tumors in mice cell

Adapted from Hasler 1998

## 2. Probiotic and Prebiotics as Functional Foods

One of the more sophisticated approaches to customizing health benefits is the use of probiotics. Probiotic(s), derived from the Greek words meaning “for life” (Lyons, 1987), are defined as “live microorganisms that confer a health effect on the host when consumed in adequate amounts” (Guarner and Schaafsma, 1998). *Bifidobacterium* and *Lactobacillus* species have been the focus of probiotic interest as large populations of these bacteria in the intestinal tract are generally considered indicative of a healthy microbiota (Ballongue, 1998; Freter, 1992; Mikelsaar *et al.*, 1998). Ele Metchnikoff was the first to observe the health benefit of probiotics. He suggested that the long life of Bulgarian peasants resulted from their consumption of a fermented milk product. The *Lactobacilli* they consumed beneficially altered the microflora of the colon and decreased raw toxic effects of other colonic microorganisms. His concept has become widely accepted and is driving today’s research, product development, and marketing of functional foods. Bacteria are being included in increasing numbers as functional ingredients, particularly in dairy products such as yogurts and fermented milks, as the evidence accumulates that they confer beneficial effects on human health (Mattila-Sandholm *et al.*, 1999; Crittenden *et al.*, 2001).

Most research on probiotics *in vitro* has been done using only a few bacterial strains or combinations of strains at different doses (Table 2). Animal and human studies have shown probiotics can produce beneficial effects on human health. According to recent reviews (Roberfroid, 2000; Rolfe, 2000), probiotics improve bodily functions in the following manner :

Table 2. Postulated beneficial health effects of probiotics and prebiotics

Functional effects	References	
	Probiotics	Prebiotics
Alleviation of lactose intolerance	Kim and Gillard 1983, Pettoello Mantovani <i>et al.</i> 1989, Sanders 1993, Marteau <i>et al.</i> 1997, Goldin 1998	Not available
Stimulation of gut immunity	Gill <i>et al.</i> 2000, Kato <i>et al.</i> 1999, Perdigon <i>et al.</i> 1995, Marteau and Rambaud 1993, Schiffirin <i>et al.</i> 1995, Famularo <i>et al.</i> 1997	Not available
Prevention of pathogen colonization	Bernet <i>et al.</i> 1993, Hudault <i>et al.</i> 1997, Pascual <i>et al.</i> 1999	Gibson and Roberfroid 1995, Roberfroid <i>et al.</i> 1998, Loo <i>et al.</i> 1999. (Strong)
Lowering of serum cholesterol	Fukushima and Nakano 1996, Mohan <i>et al.</i> 1995, Mohan <i>et al.</i> 1996,	Kok <i>et al.</i> 1998, Roberfroid and Delzenne 1998, Davidson <i>et al.</i> 1998 (Preliminary)
Reduction in inflammatory reactions	Adawi <i>et al.</i> 1997, Perdigon <i>et al.</i> 1991	Not available
Hypolipidemia	Not available	Jackson <i>et al.</i> 1999, Loo <i>et al.</i> 1999, Canzi <i>et al.</i> , 1995, Delzenne and Kok 1999 (Promising)
Increased production of short-chain fatty acids	Not available	Campbell <i>et al.</i> 1997, Djouzi and Andrieux 1997

(Table 2. Con'd)



Modification of the gut flora	Fuller and Gibson 1997, Hofacre <i>et al.</i> 1998, Hosono <i>et al.</i> 1997 (Preliminary )	Gibson and Wang 1994a, Kleessen <i>et al.</i> 1997, Kruse <i>et al.</i> 1999, McBain and Macfarlane 1997, Wang and Gibson 1993, Gibson <i>et al.</i> 1995, Gibson and Roberfroid 1995, Roberfroid <i>et al.</i> 1998, Loo <i>et al.</i> 1999 (Strong)
Disease risk reduction	Probiotics	Prebiotics
Prevention of cancer	McIntosh <i>et al.</i> 1999, Pool-Zobel <i>et al.</i> 1993, Singh <i>et al.</i> 1997	Reddy <i>et al.</i> 1997, Rowland <i>et al.</i> 1998
Reduction of food-allergies	Majamaa and Isolauri 1997, Peltto <i>et al.</i> 1998,	Not available
Improvement of the bioavailability of minerals	Not available	Coudray <i>et al.</i> 1997, Delzenne <i>et al.</i> 1995, Ohta <i>et al.</i> 1995, Heuvel <i>et al.</i> 1999 (Promising)
Diarrhea	Gibson <i>et al.</i> 1995, Corthier 1997, Isolauri <i>et al.</i> 1991, Saavedra <i>et al.</i> 1994. (Promising)	Not available
Constipation	Not available	Reddy 1998, Gibson <i>et al.</i> 1995 (Promising)

Adapted from Simmering and Blaut 2001, and Rolfe 2000

### 1) Alleviation of lactose intolerance

This effect may be due to either of two probable mechanisms, either the reduction of lactose in the dairy diet through fermentation with lactase-positive strains or the growth of a probiotic in the gastrointestinal tract which releases lactase.

### 2) Decrease of diarrhea

Diarrhea is a symptom that is closely related to the health of the gastro-intestinal tract. Many studies have shown positive effects of probiotics on antibiotic-induced diarrhea, traveler's diarrhea, HIV/AIDS diarrhea, and rotavirus diarrhea.

### 3) Immune enhancement

Animal studies showed that the ingestion of probiotics stimulated intestinal IgA and the production of cytokines by blood mononuclear cells. Erickson and Hubbard (2000) indicated that a probiotic treatment demonstrated putative effects on modulation of immune function such as enhancing phagocytosis; the mechanisms of which are still unclear.

### 4) Decreased carcinogenesis

Accumulating evidence shows that numerous intestinal flora influence carcinogenesis by production of enzymes that transform precarcinogens into carcinogens. Consumption of probiotics has reduced levels of fecal microbial enzymes such as  $\beta$ -glucuronidase,  $\beta$ -glucosidase, nitroreductase and urease, all related to carcinogenesis.

Numerous other positive effects have been reported, including a hypocholesterolemic effect, decreased inflammatory bowel disease and decreased incidence of colon cancer, etc. Generally, probiotic treatments show positive effects; however, there is still no convincing evidence available to support specific health claims for any particular strain of probiotics. (O'Sullivan and Kullen, 1998).

The proposed mechanisms of action of probiotics range from 1) production of inhibitory substances, such as organic acids, hydrogen peroxide and bacteriocins 2) blocking of adhesion sites on epithelial surfaces, along with volatile fatty acid production, resulting in competitive inhibition (Rolfe, 2000; Conway *et al.*, 1987; Goldin *et al.*, 1992; Kleeman and Klaenhammer, 1982; Starvic, 1987) 3) competition for nutrients (probiotic may utilize nutrients otherwise consumed by pathogenic microorganism) 4) degradation of toxin receptor (Rolfe, 2000; Castagliuolo *et al.*, 1996 and 1999) to 5) stimulation of immunity (Rolfe, 2000; Fukushima *et al.*, 1998; Kaila *et al.*, 1992; Link-Amster *et al.*, 1994; Malin *et al.*, 1996; Perdigon *et al.*, 1986; Pouwels *et al.*, 1996; Saavedra *et al.*, 1994)

### **3. Oligosaccharides as Prebiotics**

To be effective, probiotics must reach the large intestine. However, there are barriers in the human body to delivery of the intestinal live bacteria *via* foods, primarily acidic pH in the stomach and degradative enzymes and bile in the small intestine. These barriers lower the delivery rate of live probiotic bacteria to the large intestine. Researchers have tried to isolate strains resistant to bile and acidic conditions (Kociubinski *et al.*, 1999; Chung *et al.*, 1999) or to develop protective microencapsulation technology that involves encasing bacteria into inert carriers with limited success (Forssell *et al.*, 1999).

An alternative to direct ingestion of live bacteria into the colon through dietary supplementation is to increase populations of natural *Bifidobacteria* and *Lactobacilli* in the intestinal microbiota through the use of prebiotics. Prebiotics are nondigestible dietary components that pass through the digestive tract to the colon and selectively stimulate proliferation and/or activity of desired populations of bacteria *in situ* (Gibson and Roberfroid, 1995; Loo *et al.*, 1999). Due to a potential synergy between probiotics and

prebiotics, foods containing a combination of these ingredients are often referred to as synbiotics (Collins and Gibson, 1999; Gibson and Roberfroid, 1995). The probiotics identified thus far are nondigestible carbohydrates, including lactulose, inulin, and a range of oligosaccharides (Crittenden, 1999; Crittenden *et al.*, 2001).

A number of different oligosaccharides have shown stimulation of growth of probiotic strains and are now widely used as prebiotics. The term oligosaccharide is applied to short saccharide polymers, joined by glycosidic bonds, ranging from two to ten monosaccharide units. Many of these oligosaccharides were originally used as sweeteners in foods. They are now regarded as “soluble fiber”. They have a common property of being resistant to attack by human and animal digestive enzymes and are not directly absorbed by the host. For this reason, they are considered to be low calorie materials. Basically, oligosaccharides are produced by several methods (Morgan *et al.*, 1992; Chesson, 1993; Monsan *et al.*, 1995)

These include:

- extraction from plant sources (e.g. fructooligosaccharides,  $\alpha$ -galactooligosaccharides)
- controlled enzymatic hydrolysis of polysaccharides (e.g fructooligosaccharides, xylooligosaccharides)
- enzymatic synthesis (e.g. fructooligosaccharides,  $\alpha$ -glucooligosaccharides,  $\beta$ -glucooligosaccharides,  $\beta$ -galactooligosaccharides)

### **3.1 Types**

- Fructooligosaccharides (FOS)

These oligosaccharides have attracted serious commercial interest as prebiotics. They are composed of a D-glucopyranose unit at the non-reducing end (G) linked  $\alpha$ -1,2 to two or

more  $\beta$ -2,1-linked fructosyl units (F). This group includes 1-kestose (GF2), nystose (GF3), and 1F-fructofuranosyl nystose (GF4). These compounds marketed commercially as Raftilose and Nutraflora in the United States, are produced from three different sources. They can be extracted from plants. Onions (Shiomi, 1978) and asparagus (Shiomi *et al.*, 1976) contain particularly high amounts of fructooligosaccharides compared to other plant sources (Fishbein *et al.*, 1988). They can be produced by controlled (limited) enzymatic hydrolysis of inulin polymers from chicory or Jerusalem artichokes (Heinz and Vogel, 1991). Raffineries Tirllemontoises in Belgium uses a production process based on this method. The third route is by enzymatic synthesis from sucrose using a fructosyltransferase (EC 2.4.1.100) from *Aspergillus niger* or *Aureobasidium pullulans* (Hidaka *et al.*, 1988; Hidaka and Hirayama, 1991). The synthesis occurs according to the following reaction:

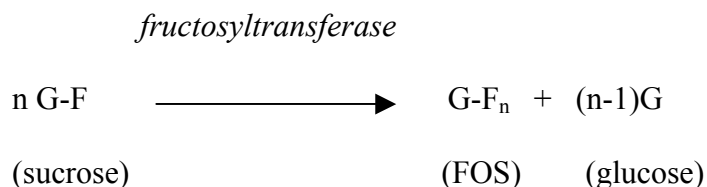

The FOS products Neosugar® and Nutraflora are produced this way. These products generally contain a proportion of glucose and sucrose that can be used by most other bacteria. To obtain products with higher FOS content, chromatography is used to separate glucose and sucrose from the reaction mixture. FOS are self-affirmed by their manufacturers as GRAS (generally recognized as safe) (Speigel *et al.*, 1994) and have been added to infant formulas, yogurt and other food products and food supplements (Kaplan and Hutkins, 2000).

- $\alpha$ -Isomaltooligosaccharides

$\alpha$ -Isomaltooligosaccharides contain  $\alpha$ -1,6 bonds and are generally obtained from starch hydrolysates (maltose and maltodextrins) through the action of the  $\alpha$ -transglucosidase (EC

2.4.1.24) from *Aspergillus* sp. (Roper and Koch, 1988). Maltose and maltodextrins can act as both glucosyl donor and acceptor to this enzyme. Hayashibara Corp. in Japan developed this transglucosylation reaction to an industrial process (Yoneyama *et al.*, 1992).

An alternative method for producing isomaltooligosaccharides is by  $\alpha$ -amylase (EC 3.2.1.3) and  $\alpha$ -glucosidase, combined with a pullulanase (EC 3.2.1.41). This process was developed by the Showa Sangyo Co., (Yasuda *et al.*, 1986). Isomaltooligosaccharide production from starch, which is a cheaper raw material than sucrose, is by the hydrolysis of starch by  $\alpha$ -amylase and pullulanase and then transglucosylation of the glucose moiety of the maltose by  $\alpha$ -glucosidase to synthesize  $\alpha$ -glucooligosaccharides, linked mainly  $\alpha$ -1,6 in concentrated carbohydrate solutions. Isomaltooligosaccharides can also be obtained from transglucosylation reactions using a neopullulanase (EC 3.2.1.135) from *Bacillus stearothermophilus*, which has been modified by site-directed mutagenesis (Kuriki *et al.*, 1993). There are some disadvantages in this production method. All these processes are multi-step requiring gelatination, liquefaction, saccharification, and purification and there are always some mono-, and/or disaccharides in the final product (Yoo, 1997).

Branched  $\alpha$ -isomaltooligosaccharides can also be produced by an acceptor-reaction catalyzed with dextransucrase (EC 2.4.1.5). The dextransucrase from *L. mesenteroides* NRRL B-1299 can produce  $\alpha$ -glucooligosaccharides (GOS) containing one or more D-glucopyranosyl branch units linked *via*  $\alpha$ -1,2 glycosidic bonds if maltose supplied as an acceptor (Paul *et al.* 1992, Remaud-Simeon *et al.* 1994).

- $\alpha$ -Galactooligosaccharides

$\alpha$ -Galactosyl derivatives of sucrose are present in many legume seeds. Mono-, di-, and tri- $\alpha$ -galactosylsucrose, known respectively as raffinose, stachyose, and verbascose, are produced

by extraction from plants, particularly soybeans (Minami *et al.*, 1983). These oligosaccharides are known to be, in part, responsible for the flatulence and diarrhea that follows consumption of beans, because of the absence of an  $\alpha$ -galactosidase in the gastrointestinal tracts of humans and animals.

- Others

A variety of  $\beta$ -glycooligosaccharides can be obtained by enzymatic methods (Fujii and Komoto, 1991), but these are not available in sufficient quantities or at a sufficiently low cost to allow their use as additives in foods. Laboratory studies have shown that they are as resistant to the action of host digestive enzymes as the previously described oligosaccharides.  $\beta$ -Glucooligosaccharides are obtained when highly concentrated glucose solutions (70%, w/w) are treated with  $\beta$ -glucosidase (EC 3.2.1.21) (Ajisaka *et al.*, 1987). The reaction produces a mixture of di- and trisaccharides containing mainly  $\beta$ -1,6 (gentiobiose, gentiotriose) and  $\beta$ -1,4 (cellobiose, cellotriose) glycosidic linkages. Transgalactosylation of lactose by  $\beta$ -galactosidase (EC 3.2.1.23) produces  $\beta$ -galactooligosaccharides. The yield depends on the enzyme-producing microbial source and on the lactose concentration (Mozaffar *et al.*, 1984; Prakash *et al.*, 1987).  $\beta$ -Xylooligosaccharides can be produced by enzymatic hydrolysis of plant xylans (Morgan *et al.*, 1992). They can also be found naturally in bamboo shoots, which are eaten in Asia (Imaizumi *et al.*, 1991). The efficiency of action of endoxylanases (EC 3.2.1.8) is influenced by the presence of arabinofuranosyl side chains in the xylan polymer (Kormelink *et al.*, 1992). Interest in the use of xylanases and related enzymes by the pulp, paper and feed industries is increasing the availability of this enzyme. (Monsan *et al.*, 1995). Cyclomalto-oligosaccharides (cyclodextrins, CDs) are composed of glucose units linked by  $\alpha$ -1,4

linkage in a ring structure. Branched CDs in which the maltose or glucose molecules are linked by  $\alpha$ -1, 6 linkages to CDs were produced for the purpose of increasing the solubility of CDs. Cyclomalto- oligosaccharides have been used as complexing agents for the stabilization of oily unstable substances and for modifying the physical properties of insoluble and volatile materials such as flavors because of their ability to form inclusion complexes (Kobayashi *et al.*, 1989).

### **3.2 Beneficial Effects of Oligosaccharides**

Ingested oligosaccharides (prebiotics) are able to reach the colon. It has been proposed that these oligosaccharides are preferentially utilized by *Lactobacilli* and bifidobacterial species (Kaplan and Hutkins, 2000). This would increase the intestinal production of lactic acid and short-chain fatty acids (SCFA), resulting in lower pH in the large intestine that may help prevent the establishment of undesirable pathogenic organisms such as *Salmonella* (Juven *et al.*, 1991). The oligosaccharides may also interact with carbohydrate receptors present on the surface of either microbial or epithelial cells, affecting cell adhesion and immunomodulation. (Howard *et al.*, 1995; Naughton *et al.*, 2001)

Fructooligosaccharides and some branched glucooligosaccharides are not digested in the human small intestine, but can be fermented by certain microorganisms found in human and livestock intestines, especially by the *Bifidobacterium* sp. (Tomomatsu, 1994). There are numerous reports regarding stimulating effects of oligosaccharides on the growth of probiotic strains. Nagendra *et al.* (1995) reported that infants fed with a control formula without lactose had coliforms as the predominant flora and those fed with lactose-containing formula had bifidobacteria as the predominant flora. Gibson and Wang (1994a) found that the growth rate of seven of the eight bifidobacterium species they tested were higher on



fructooligosaccharides than on glucose, the only exception being *B. bifidum*. In a study using a simulated human intestinal microbial ecosystem reactor (Molly *et al.*, 1996), called SHIME, consisting of six closed vessels with a milk containing *L. acidophilus* and fructooligosaccharide (FOS), the FOS stimulated bifidobacteria growth. Gmeiner *et al.* (2000) reported the consumption of a mixture of *L. acidophilus* with FOS increased the population of Bifidobacteria. They also observed increases in amounts of volatile fatty acids, especially butyric and propionic acids.

In glucooligosaccharide (GOS) studies, Flickinger *et al.* (2000) studied *in vitro* fermentation characteristics using human fecal material, as well as the small intestinal digestibility and the effects on fecal microbial populations in dogs, with a GOS containing  $\alpha$ -1,2,  $\alpha$ -1,4 and  $\alpha$ -1,6 linkages, FOS, and others. In *in vitro* tests, GOS and FOS produced short chain fatty acids in human fecal material more rapidly than the other substrates, such as gum arabic, guar gum and guar hydrolysate. GOS appeared to be indigestible in the small intestine, while supplying a carbon source for bacterial fermentations in the large intestine of cannulated dogs. When the viable count of *B. infantis* and *B. longum*, and changes in pH of 1.0% of various carbohydrates supplemented soymilk were monitored, *B. longum* showed a significantly ( $P < 0.05$ ) higher count on a crude isomaltooligosaccharide (75%) supplemented soymilk than in the control (soymilk without the added supplement) at the end of fermentation (Chou *et al.*, 2000). In another study, Valette *et al.* (1993) showed that GOS was only 20% digested by germfree rats. Dietary isomaltooligosaccharides (13.5g/day for 14 days), another type of GOS, are reported to increase fecal bifidobacteria levels ( $P < 0.05$ ) in healthy adult males (Kohmoto *et al.*, 1988). Djouzi *et al.* (1995) investigated the ability of several human gut bacteria to break the  $\alpha$ -1,2 and  $\alpha$ -1,6 glycosidic linkages in GOS, *in vitro*,

in substrate utilization tests. Branched oligomers were resistant to both gastrointestinal enzymes and utilization by pathogenic microorganisms. They also reported  $\alpha$ -1,2 glucosidic bonds were more resistant than  $\alpha$ -1,6 linkages in kinetic studies on glucooligosaccharide hydrolysis in pH-regulated fermentations. *Bifidobacterium* utilizes GOS. Bifidobacteria concentrations also increased when GOS was added to the diet of cannulated dogs (Flickinger *et al.*, 2000). Ingestion of either fructooligosaccharides, or branched oligosaccharides, increased the populations of indigenous bifidobacteria in the colon. As the result of higher populations of these bacteria, the pH of digestive tract was lowered and the growth of putrefactive bacteria such as *Escherichia*, *Salmonella*, *Clostridia* was suppressed (Tomomatsu, 1994).

In addition to its role as a source for increasing probiotic bacteria population, oligosaccharides are used in processed foods because of other properties. For example, branched oligosaccharides are milder and softer in taste (Yoo *et al.*, 1995) and have relatively low viscosity and water activity compared to sucrose. Their low water activity makes them effective in controlling microbial contamination in processed foods (Yoo *et al.*, 1995). The xylosylfructosides inhibit the sucrose-splitting activity of glucosyltransferases of *Streptococcus mutans*, one of the oral microorganisms implicated in plaque formation (Gore *et al.*, 1988). Others such as maltooligosaccharides, isomaltulose, and trehalose act as alternative acceptors for glucosyl transfer reactions from sucrose reducing formation of insoluble glucans. This makes these oligosaccharides anti-cariogenic. With increasing health consciousness of consumers, functional properties such as low calories, anti-cariogenicity, and bifidobacteria growth-promoting factor has expanded the usage of these polysugars (McKellar and Modler, 1989; Oku *et al.*, 1984; Pszczola, 1988; Spiegel *et al.*, 1994).

## 4. Enzyme and Mechanism of Synthesis of $\alpha$ -Glucooligosaccharides

### 4.1 Glucansucrases (Dextransucrases)

Glucansucrases have been extensively studied because of their role in the production of dextran and its role in the cariogenic process. Glucansucrases (EC 2.4.5.1), usually extracellular but in some cases are cell-associated, are mainly produced by soil bacteria. Those produced by *Leuconostoc* sp. are called dextransucrase and *Streptococcus* sp. and other lactic bacteria, *Lactococci*, are called glucosyltransferases (Sidebotham, 1974). Streptococcal glucansucrases synthesize primarily  $\alpha$ -1,3 rich polysaccharides. *Leuconostoc* glucansucrases produce  $\alpha$ -1,6 rich polysaccharides. Genes coding for glucansucrases-producing branched glucans through  $\alpha$ -1,2 or  $\alpha$ -1,4 glucosidic bond or synthesizing alternan, a glucan that has an alternating sequence of  $\alpha$ -1,6 and  $\alpha$ -1,3 linkage having approximately 50% of  $\alpha$ -1,6 and 50% of  $\alpha$ -1,3 linkages, have not been isolated.

Glucansucrases catalyze the synthesis of high molecular weight D-glucose polymers from sucrose. In the presence of efficient acceptors, they may catalyze the synthesis of low molecular weight oligosaccharides (Koepsell *et al.*, 1952). Glucosidic bond synthesis occurs without the mediation of nucleotide activated sugars and cofactors are not necessary. Glucansucrases were first identified more than a half century ago. The first glucansucrase gene was cloned in the late 1980's. However, the mechanism of glucansucrase action is still incompletely understood. The cloning of glucansucrase genes has allowed, in addition to structure-function relationship studies, the identification of important amino acid residues in these enzymes (Monchois *et al.*, 1999b).

#### 4.1.1 Structure and Function

More than 30 genes encoding sucrose GTF (also named glucansucrase) have now been identified. (For individual gene reference, see Remaud-Simeon *et al.*, 2000, Monchois *et al.*, 1999b). In spite of the importance of defining the three-dimensional structure of an enzyme, the crystallization of *Leuconostoc* and *Streptococci* glucansucrases still defies crystallographers, probably because of the large size, an avg. of 160kDa (between 155 to 200 kDa) and the flexibility of these proteins. Biochemical studies, sequence alignment analysis, hydrophobic cluster analysis and structural predictions have revealed that sucrose GTF shares many mechanistic and structural features with glycoside hydrolases and particularly with  $\alpha$ -amylase, cyclodextrin glucanotransferase and pullulanase, which on the basis of sequence alignment, have been shown to belong to family13 (Henrissat and Bairoch, 1996). These proteins contain four distinct regions: a signal peptide, a variable region and an N-terminal catalytic domain followed by a C-terminal glucan binding domain (GBD) (Ferretti *et al.*, 1987; Simpson *et al.*, 1995; Russell, 1990; Giffard *et al.*, 1993; Vickermann *et al.*, 1997)

The schematic structure of glucansucrase is shown in figure 1.

- 1<sup>st</sup> region: N-terminal end (signal peptide region)

This region is typical of the signal peptide region of Gram-positive bacteria. All the GTFs, except the glucansucrase encoding gene (DSR-A) from *L. mesenteroides* NRRL B-1299 have, at the N-terminal end, a signal peptide region of 32 to 38 amino acids. This region is highly conserved, sharing more than 40 - 50% identical or functionally equivalent residues. This may indicate that the glucansucrases of different species have similar secretion pathways. (Monchois *et al.*, 1996)

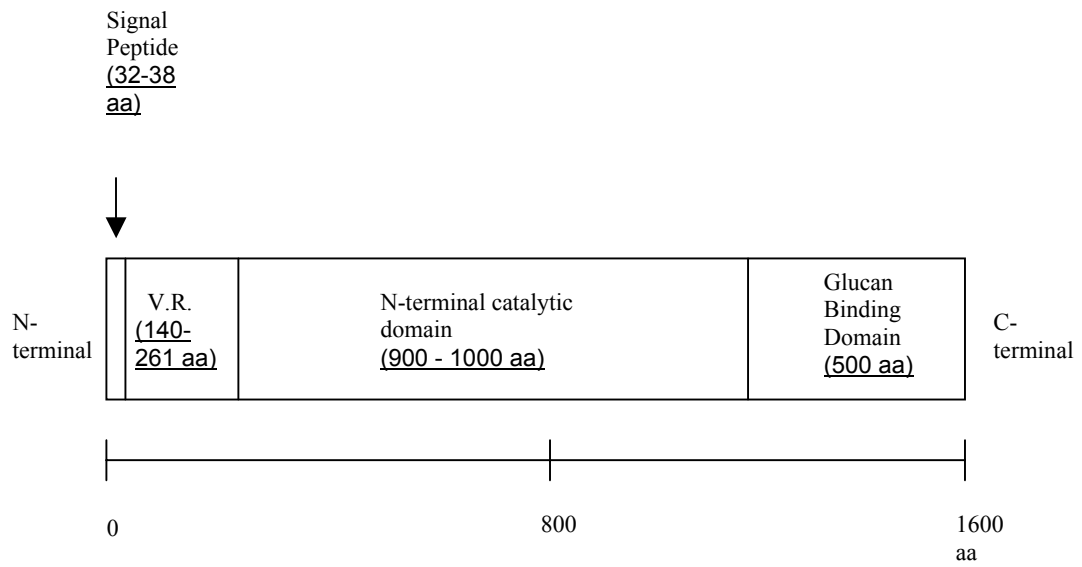

Figure 1. General schematic diagram of a glucansucrase. (V.R., Variable Region)

- 2<sup>nd</sup> region: Variable region

A variable region of 140 to 261 amino acids follows the signal peptide region. The amino acid sequence of this region has not been extensively investigated. It has been suggested that because of its high variability this region could be a tracer specific for each GTF (Banas *et al.*, 1994). It may not have an important role in the protein because the DSR-A, isolated from *L. mesenteroides* NRRL B-1299 does not possess this variable region (Monchois *et al.*, 1999a). The significance of this variable region remains unknown.

- 3<sup>rd</sup> region: N-catalytic domain

The region immediately following the variable region is a highly conserved region of about 900 -1000 amino acids, named the N-catalytic domain because it contains the essential aspartic acid involved in the glucosyl-enzyme intermediate (Mooser *et al.*, 1991; Kato *et al.*, 1992). Further investigations are needed to confirm the functional or structural role of these residues and to demonstrate how they may function differently depending on the specificity of the glucansucrase.

- 4<sup>th</sup> region: C-terminal glucan binding domain (GBD)

At the carboxyl terminal end, glucansucrases from *L. mesenteroides* or *Streptococcus* species strains possess a GBD of about 500 amino acids (Ferretti *et al.*, 1987; Abo *et al.*, 1991; Russell, 1990; Giffard *et al.*, 1993) that contains several different homologous repeats (Ferretti *et al.*, 1987; Russell, 1990; Giffard *et al.*, 1991; Monchois *et al.*, 1998). The organization and number of repeats vary with the different glucansucrases. Although GBD is not directly involved in either sucrose cleavage, glucan synthesis or oligosaccharide synthesis, its presence modulates the initial rate of the reaction (Ferretti *et al.*, 1987; Abo *et al.*, 1991; Kato *et al.*, 1992; Lis *et al.*, 1995). Truncation of the C-terminal end suppresses

glucan binding abilities of the GTF of *S. sobrinus*. The repeat region is not directly involved in the solubility of the glucan produced (Nakano and Kuramitsu, 1992) but oligosaccharide size distribution is modified when the C-terminal domain is partially deleted (Monchois *et al.*, 1998; Remaud-Simeon *et al.*, 2000)

#### 4.1.2 Mechanism of Action

Enzymological studies have led to different models for the mechanism of the action. The use of secondary structure prediction has led to a clearer knowledge of structure-function relationships of glucansucrases. However, mainly due to the large size of these enzymes, data on the three-dimensional structure of glucansucrases (given by crystallography and modeling) necessary to clearly identify those features that determine function is missing (Monchois *et al.*, 1999b).

##### 4.1.2.1 Glucan (Dextran) Synthesis

Dextransucrases catalyze the synthesis of high molecular weight glucans (dextrans) according to the reaction:

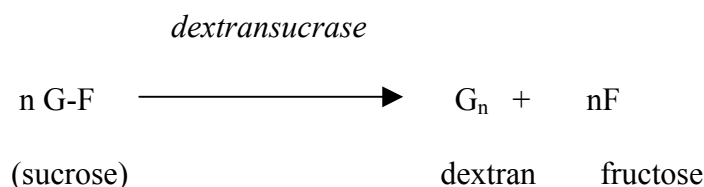

Dextran is a D-glucose polymer composed mainly of  $\alpha$ -1,6 linked backbones in a linear chain and  $\alpha$ -1, 2,  $\alpha$ -1,3, and/or  $\alpha$ -1,4 branch linkages (Jeanes *et al.*, 1954). The chemical structure of the dextran is specific to the glucansucrase of the producing strain (Table 3). Usually a high molecular weight dextran ( $10^6$ - $10^7$  Da) is produced. This is the case, for example, of the enzyme from *L. mesenteroides* NRRL-512F, which is used to produce dextran polymers of industrial interest including chromatography supports,

Table 3. Linkages in different dextrans as obtained by methylation analysis

Dextran <sup>a</sup>	Solubility	Linkages %				
		$\alpha$ -1→6	$\alpha$ -1→3	$\alpha$ -1→3 Br <sup>b</sup>	$\alpha$ -1→2 Br <sup>b</sup>	$\alpha$ -1→4 Br <sup>b</sup>
<i>L. m.</i> B-512F	Soluble	95	5			
<i>L. m.</i> B-742	Soluble	50		50		
<i>L. m.</i> B-742	Less soluble	87				13
<i>L. m.</i> B-1299	Soluble	65			35	
<i>L. m.</i> B-1299	Less soluble	66		1	27	
<i>L. m.</i> B-1355	Soluble	54	35	11		
<i>L. m.</i> B-1355	Less soluble	95		5		
<i>S. m.</i> 6715	Soluble	64		36		
<i>S. m.</i> 6715	Insoluble	4	94	2		

<sup>a</sup>*L. m.*, *Leuconostoc mesenteroides*; *S. m.*, *Streptococcus mutans*. <sup>b</sup> Br, Branch linkage.  
Adapted from Robyt 1986



photographic emulsions, iron carrier, and blood plasma substitutes (Robyt, 1986).

Mechanistic studies of production of dextran from B-512F and mutan from *S. mutans* 6715 have indicated that formation of a covalent bond between the enzyme and sucrose initiates synthesis (Figure 2A). In glucose or fructose medium, in the absence of sucrose, *Leuconostoc mesenteroides* produces extracellular dextransucrases, although, at levels much lower than in the presence of sucrose (Dols *et al.*, 1998). Sucrose is the only known practical inducer. Dextransucrase production is restricted to the active growth phase (Robyt and Walseth, 1978). The destination of glucosyl residues from sucrose will be a pathway; dextran if it goes to a polymer being synthesized, oligosaccharides if it is added to an acceptor. Dextransucrase is believed to work by a single chain mechanism (Robyt and Taniguchi, 1976), where the enzyme normally remains attached to the growing dextran chain at the reducing end of the polymer. The enzyme hydrolyzes sucrose, transferring the D-glycopyranosyl residue to a glucose chain. The termination step of the reaction is not completely understood, but under normal conditions dextransucrase seems to be released slowly from the polymer (Ditson and Mayer, 1984).

Glucan synthesis initiation can occur in the absence of an exogenous primer, but addition of exogenous glucan makes the enzyme more active (Robyt and Corrigan, 1977). Elongation of glucan, especially the mechanism of autopolymerization and direction of chain growth, is still not fully understood. It is most likely that the elongation of glucan occurs at the reducing end of the glucan chains (Robyt *et al.*, 1974; Robyt and Martin, 1983; Ditson and Mayer, 1984). It has been proposed that glucan synthesis is a result two nucleophilic sites in the active site of the enzyme that attack sucrose and displace fructose producing two  $\beta$ -glucosyl intermediates (Robyt 1986). The two nucleophilic sites first

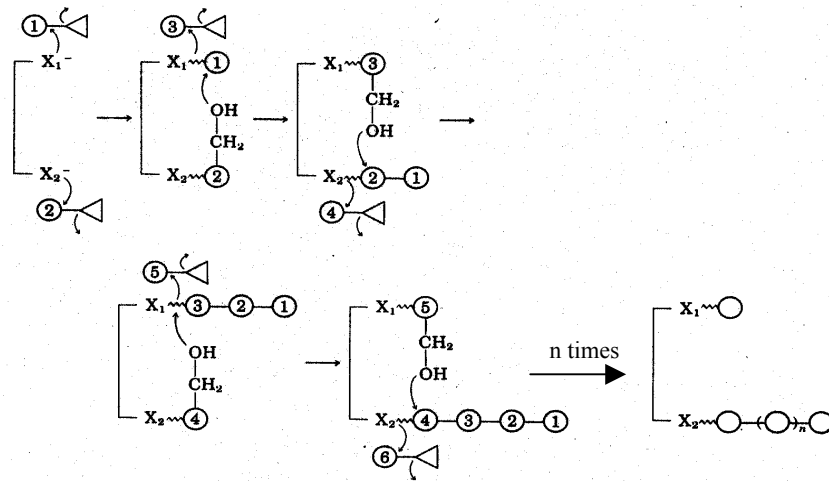

A. Dextran synthesis

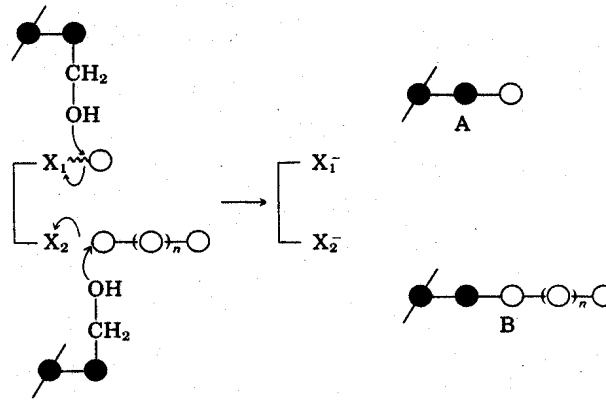

B. Acceptor reaction

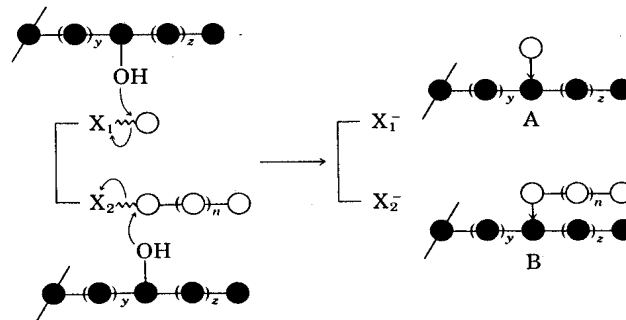

C. Formation of branch linkages in dextran

Figure 2. Various mechanisms for the synthesis  $\alpha$ -1,6 glucan by *L. mesenteroides* B- 512F (ATCC 10830).  $\circ-\triangle$ , sucrose;  $X_1$  and  $X_2$ , nucleophiles of active site in enzymes;  $\bullet-\bullet$  in B, acceptor (isomaltose or maltose). Adapted from Robyt 1986

attack two sucrose molecules and result in two glucosyl residues covalently linked to the enzyme. Secondly, the C<sub>6</sub>-OH group of one of the glucosyl residues attacks C<sub>1</sub>-OH of the other to form an α-1,6 linkage and one glucosyl residue is transferred to the other. The freed nucleophile attacks another sucrose molecule, forming a new enzyme glucosyl intermediate. The C<sub>6</sub>-OH of this new glucosyl intermediate attacks the C<sub>1</sub> of the isomaltosyl unit (the growing dextran chain), which is in effect transferred to the glucosyl residue. The glucosyl and dextranosyl units are alternately transferred between the two nucleophiles as the dextran chain is elongated at the reducing end. As these steps are repeated, the glucan elongation continues. The elongation is terminated and the chain released by acceptor reactions, one of which may be with an exogenous dextran chain to give a branch linkage (Robyt, 1986). Monchois *et al.* (1999b) pointed out that this proposition is not a perfect explanation of glucan synthesis because, up to now, only one site (an aspartic acid) capable of making a covalent bond with the glucose moiety coming from the breakdown of sucrose has been identified (Mooser and Iwaoka, 1989) and it is difficult to understand how the C<sub>6</sub>-OH group is able to attack the C<sub>1</sub>-OH of the other glucosyl residues by this mechanism.

#### **4.1.2.2 Oligosaccharide Synthesis (Acceptor Reaction)**

In 1952, Koepsell *et al.* (1952) described the synthesis of oligosaccharides at the expense of dextran synthesis. In the presence of sucrose, they observed that introduction into the reaction medium of molecules, like maltose, isomaltose, and *O*-α-methylglucoside, shifted the pathway of glucan synthesis towards the production of oligosaccharides (Figure 2B). The enzyme was shown to transfer the D-glucosyl group of sucrose to mono- or disaccharides such as glucose, maltose or isomaltose, which were called acceptors (Koepsell

*et al.*, 1952). Since then, the so-called “acceptor” reaction catalyzed by the glucosyltransferase from *L. mesenteroides* NRRL B-512F has been extensively described.

Acceptors can substitute for the glucopyranosyl residue, terminating chain growth. These compounds do not act as primers, but rather they terminate polymerization (Roby and Walseth, 1979). The order of preference for chain terminating acceptors of the dextran reaction is species specific. Many sugars acting as acceptors are classified both according to their capacity to divert the glucosyl residues from dextran to form oligosaccharides and by their effect on the rate of reaction. Among acceptors, maltose and isomaltose have been demonstrated to be the most effective acceptors for dextransucrase (Roby and Walseth, 1978; Roby and Ecklund, 1983). Because of its high acceptor efficiency, maltose has been widely used in the cell free synthesis of oligosaccharides by dextransucrase (Smiley *et al.*, 1982).

The acceptor efficiency of a large variety of sugars (monosaccharides, disaccharides, dextran) and the structure of the synthesized products has been determined. Maltose and isomaltose were found to be the most efficient acceptors among the mono- and disaccharides (Roby, 1986). In both cases, the enzyme transfers the glucosyl group to the non-reducing end of the disaccharide by synthesis of an  $\alpha$ -1,6 glucosidic bond. The acceptor reaction product may in turn be glucosylated and a series of linear oligosaccharides is produced. (Remaud *et al.*, 1992). The mechanism of acceptor reaction proposed by Roby and Walseth (1978) was that only one covalent glucosyl-enzyme complex is necessary and acceptor molecules will be incorporated at the reducing end of the glucan or the oligosaccharide produced. Oligosaccharide elongation might occur at the reducing end. Oligosaccharides may be synthesized by a nucleophilic attack of the hydroxyl group located at the non-

reducing end of the acceptor to the C<sub>1</sub> of one of the two glucosyl residues involved in the two covalent glucosyl-enzyme complexes.

Various experiments have shown that the acceptor-binding site is really unique and separated from the two active sites, but, up to now, there is no direct evidence that a separate acceptor binding site exists (Monchois *et al.*, 1999a). Moreover, one of the two sucrose-binding sites may also be an acceptor-binding site. In DSR-S from *L. mesenteroides* NRRL-B512F, a change from Asp-551 as the site of glucosyl enzyme complex formation to asparagine, resulted in a total loss of both glucan and oligosaccharide synthesis activities. In the presence of maltose, the formation of the glucosyl-enzyme complex becomes the limiting step instead of the polymer transfer, as is the case in glucan synthesis. This might be due to a change of acceptor binding in dextransucrase. The reason why weak acceptors, such as fructose, inhibit the reaction remains unclear. A possible explanation is that these acceptors inhibit sucrose breakdown or the presence of fructose may create a steric hindrance inhibiting the growth of the glucan chain (Monchois *et al.*, 1999b).

#### **4.1.2.3 Branch Formation**

Glucan can also be regarded as an acceptor. An increase in the molecular weight of exogenous glucan by acceptor reaction was noticed (Cote and Robyt, 1983). The transfer of glucose and glucan to a glucan chain acceptor has been shown with a dextransucrase produced by *L. mesenteroides* NRRL B-512F. The phenomenon of insolubilization of exogenous glucan by formation of  $\alpha$ -1,3 linkages has also been shown with different glucansucrases. A possible explanation for formation of  $\alpha$ -1,3 linkages is they may be the result of acceptor reactions (Ebert and Brosche, 1967) because an  $\alpha$ -1,3 linkage is created between the anomeric carbon involved in one covalent glucosyl enzyme complex and the

OH-C<sub>3</sub> of a glucosyl residue of the exogenous glucan (Robyt and Taniguchi, 1976; Figure 2C). The exogenous glucan may bind in another site and one of the hydroxyl groups may exert a nucleophilic attack on the C<sub>1</sub> involved in the glucosyl or glucanosyl enzyme complex. However, this explanation is insufficient to explain the synthesis of highly branched glucans (Kim and Robyt, 1996). Cote and Robyt (1984) explained  $\alpha$ -1,3 linkages of a highly branched glucan might be synthesized by transfer of a glucosyl residue from a glucosyl enzyme site different from the two active sites to the glucan. (Monchois *et al.*, 1999b)

## **5. *Leuconostoc mesenteroides* ATCC 13146 (NRRL B-742) and Its Dextransucrase**

### **5.1 Enzyme**

*Leuconostoc mesenteroides* ATCC 13146 was isolated first by Hucker and Pederson (1930) from spoiled canned-tomatoes. The dextran produced by ATCC 13146 is highly branched, containing as much as 50%  $\alpha$ -1,3 linkages and no  $\alpha$ -1,4 linkages. The majority of the branch linkages connect only a single glucose to the main chain (Seymour *et al.*, 1979a). *Leuconostoc mesenteroides* ATCC 13146 actually produces two exocellular  $\alpha$ -D-glucans, a fraction L, which is precipitated at an ethanol concentration of 39%, and a fraction S, which is precipitated at a concentration of 45% ethanol (Robyt, 1986). Fraction L consists of an  $\alpha$ -1,6 backbone with  $\alpha$ -1,4 branch-points, and fraction S consists of an  $\alpha$ -1,6 backbone with  $\alpha$ -1,3 branch-points. The L fraction from *Leuconostoc mesenteroides* ATCC 13146 contains 87 %  $\alpha$ -1,6 linkages and 13%  $\alpha$ -1,4 linkages. The percentage of  $\alpha$ -1,3 branch-points in the fraction S glucan is variable, dependant on the conditions under which it is synthesized from sucrose. The S fraction is a polymer similar to alternan. However, the  $\alpha$ -1,3 linkages of the S fraction of *L. mesenteroides* ATCC 13146 are all branched linkages. This dextran

demonstrates extreme resistance to endodextranase. This property seems related to its structure that has the highest possible degree of branching and exhibits a comb-like structure with main chains of consecutive  $\alpha$ -1,6 linked glucose residues to which single  $\alpha$ -1,3 linked glucosyl residues are attached. (Seymour *et al.*, 1979b). Any change in reaction conditions that affects the rate of acceptor reaction relative to chain elongation also affects the degree of branching in ATCC 13146 fraction S dextran.

This glucansucrase is also capable of modifying other dextrans, such as B-512F (ATCC 10830) and B-742 (ATCC 13146) fraction L, by transferring D-glucosyl groups to OH-C<sub>3</sub> of D-glucosyl residues in these dextrans (Cote and Robyt, 1983). Denaturing SDS-PAGE showed that the ATCC 13146 strain grown on glucose or sucrose has one activity band at 184kD. The pH optimum range was 5.2 – 5.8 with the highest activity at pH 5.5. The optimum temperature range was 30 - 37°C with the highest stability at 35°C (Kim and Robyt, 1995).

## **5.2 Oligosaccharides by Acceptor Reaction**

Glucosaccharides are produced by glucosyltransferases (dextransucrase), the same enzyme that makes dextran (Figure 3). Sugar transport and phosphorylation are key elements controlling oligosaccharide production by microbial cells, but there is a shortage of information on these processes in *L. mesenteroides* ATCC 13146. In general, *Leuconostoc mesenteroides* synthesizes several key enzymes; i.e. sucrose phosphorylase and dextransucrase to utilize sucrose (Kagan *et al.*, 1942; Kobayashi *et al.*, 1986). Regulation of dextransucrase is controlled by the carbon source (Dols *et al.*, 1998). Sucrose is transported into the cell *via* a permease(s) (Dols *et al.*, 1998). Then sucrose phosphorylase, a constitutive enzyme and thought to be located intracellularly, catalyses the hydrolysis of

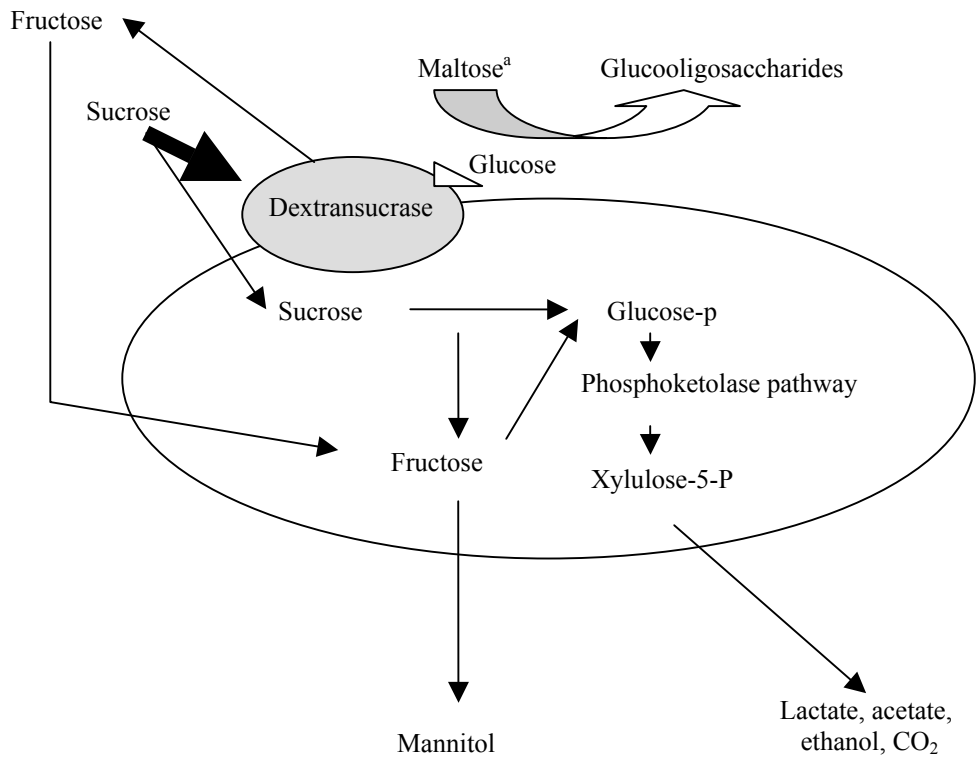

Figure 3. Schematic representation of carbon flow by *Leuconostoc mesenteroides* ATCC 13146 during metabolism. The large circle and triangle represent a cell and active site of polymerization, respectively. a. Maltose is an example of an acceptor.



sucrose, adding inorganic phosphate to the glucose moiety of the sucrose molecule producing fructose and glucose-1-phosphate. (Vandamme *et al.*, 1987; Weimberg *et al.*, 1954). Because *Leuconostoc* does not have a phosphoenolpyruvate: hexosephosphotransferase system, these bacteria phosphorylate glucose and fructose *via* ATP-dependant enzymes (Romano *et al.*, 1979; Sapic and Anderson, 1967; Romano, 1987). Glucose-1-phosphate is used to support cell growth or dextransucrase production. Dextran (or oligosaccharides if an acceptor is available) and fructose are produced by the dextransucrase (Miller *et al.*, 1986). Dextransucrase secretion in *L. mesenteroides* is dependent on a presence of proton gradient across the cytoplasmic membrane that is directed into the cell (Otts and Day, 1988).

Under anaerobic conditions, *L. mesenteroides*, a heterofermentative lactic acid bacteria, produces ethanol, lactic acid, and CO<sub>2</sub> in equal molar quantities, as byproducts from glucose, *via* the phosphoketolase pathway (DeMoss *et al.*, 1951). Increasing acetate production at the expense of ethanol production produces an additional ATP from the catabolism of glucose under aerobic conditions but presents a redox problem for the cell, as it needs to generate NAD<sup>+</sup> for catabolic functions (Ito *et al.*, 1983). In many strains of *L. mesenteroides*, the regeneration of NAD<sup>+</sup> is through an NADH oxidase that utilizes oxygen as an electron acceptor to oxidize NADH (Ito *et al.*, 1983; Lucey and Condon, 1986). Better growth is achieved by strains of *L. mesenteroides* when they produce acetate at the expense of ethanol. (Johnson and McCleskey, 1957; Lucey and Condon, 1986). However, not all strains produce NADH oxidase or generate acetate from acetyl-phosphate. These cannot make an additional ATP during glucose fermentation.

Yoo (1997) optimized reaction conditions including medium pH, temperature, and ratio of sucrose to maltose for oligosaccharide production by acceptor reaction. The process for oligosaccharide production in this study was performed using a modification of his procedures.

In the presence of an efficient acceptor sugar, such as maltose, the reaction of a dextransucrase is shifted towards oligosaccharide synthesis. The molecular weight and polydiversity of this enzyme product are dependent upon the sucrose to acceptor ratio and on the characteristics of the intermediate oligosaccharides in the reaction. The ratio of sucrose to maltose affects the composition and yield of the oligosaccharides produced by the acceptor reaction. Paul *et al.* (1986) reported, when the maltose to sucrose ratio was 2, a partially purified dextransucrase from *L. mesenteroides* NRRL B-512F produced 85% of the theoretical yield of polysaccharide as oligosaccharides, with an average DP of 4. Cote and Robyt (1983) investigated the acceptor reaction of *L. mesenteroides* ATCC 13146 and found that branch formation in this strain, when maltose was the acceptor, was dependant upon reaction conditions. In Yoo's (1997) study, *L. mesenteroides* ATCC 13146 in the presence of maltose produced 90% of the theoretical yield of polymer as oligosaccharides, under optimum conditions for sucrose fermentation. The fermentation was essentially complete in 24 hours, with oligosaccharide production being linked to growth. The production rate was about 0.9 g/L hr. The maltose to sucrose ratio was able not only to alter the yield of oligosaccharide but also to change the relative proportion of different size oligosaccharides produced by the fermentation. The highest yields of oligosaccharides were obtained when the ratio of sucrose to maltose in the fermentation was two. This is the same ratio reported for optimum oligosaccharide production *in vitro* by the dextransucrase of *L. mesenteroides*

B-512F (Paul *et al.*, 1986). Several *Leuconostoc* strains were tested to check for oligosaccharide size profiles produced in response to maltose, because individual *Leuconostoc* species synthesize different dextransucrases in response to various acceptors. The oligosaccharides produced by *L. mesenteroides* ATCC 13146 were mostly DP 3-5 glucooligosaccharides by chemical analysis. Oligosaccharides prepared by drying alcohol precipitated cell free culture broths had greater amounts of higher branched isomaltooligosaccharides up to DP 7, than commercial preparations and had no glucose and less maltose (Yoo, 1997).

### **5.3 Mannitol as Byproduct**

D-mannitol is a sugar-alcohol derived from mannose or fructose by dehydrogenation. In sucrose fermentations, mannitol is produced as an end product, as fructose can be used as an electron acceptor, but the levels of mannitol produced vary with the strain (Ferain *et al.*, 1996; Loesche and Kornman, 1976; Grobber *et al.*, 2001). The production of mannitol from fructose by lactic acid bacteria was first observed by early studies in the 1900's (Perterson and Fred 1920). The intracellular and NADH-dependent microbial enzyme, D-mannitol dehydrogenase (E.C. 1.1.1.67), converts fructose to mannitol (Vandamme *et al.*, 1987). Several species including *Lactobacillus brevis*, *Leuconostoc mesenteroides*, *Agaricus campestris*, and *Aspergillus candidus* were reported as the enzyme producing strains (Yoo, 1997). The mannitol produced is excreted by the cell (Vandamme *et al.*, 1987). The conversion of fructose to mannitol allows the cell to maintain its redox balance, thus, not all acetyl-phosphate is reduced to ethanol. Extra ATP is then available for the cell under both aerobic and anaerobic conditions, when grown on sucrose (Otts, 1987).

Mannitol is used not only in foods but also has wide application in the non-food sector. Mannitol is commonly used in pharmaceutical formulations of chewable tablets and granulated powders (Soetaert *et al.*, 1995; Debord *et al.*, 1987). A complex of boric acid with mannitol is used in the production of dry electrolytic capacitors. It is an extensively used polyol for the production of resins and in many types of surfactants. Mannitol is used in medicine as a powerful osmotic diuretic and in many types of surgery for the prevention of kidney failure and to reduce eye and brain edema. One of its derivatives, mannitol hexanitrate, is a well-known vasodilator, used in the treatment of hypertension. Nowadays mannitol is produced exclusively by catalytic hydrogenation of fructose. Worldwide production is estimated at about 30,000 tons per year.

The commercial production is performed by high-pressure hydrogenation of glucose/fructose mixtures (invert sugar or isoglucose) at high temperature with Raney-nickel as the catalyst (Wisniak and Simon, 1979). In the hydrogenation process the selectivity of the nickel catalyst is such that about half of the fructose is converted to mannitol and half of it to sorbitol. The glucose is hydrogenated exclusively to sorbitol. As a consequence, commercial production is always accompanied by the production of sorbitol, thus resulting in a less efficient process. The composition of the hydrogenated mixture is typically about 25-30% mannitol and 70-75% sorbitol. Mannitol is then recovered by crystallization, as it is far less soluble than sorbitol. Consequently the price of mannitol is about three times as high as that of sorbitol. Mannitol can also be produced by fermentation (Figure 4). Various studies using fungi and yeasts have been undertaken but none of these processes was economically successful (Soetaert *et al.*, 1995). The enzymatic conversion of fructose to mannitol is also possible, but suffers from serious drawbacks such as incomplete conversion

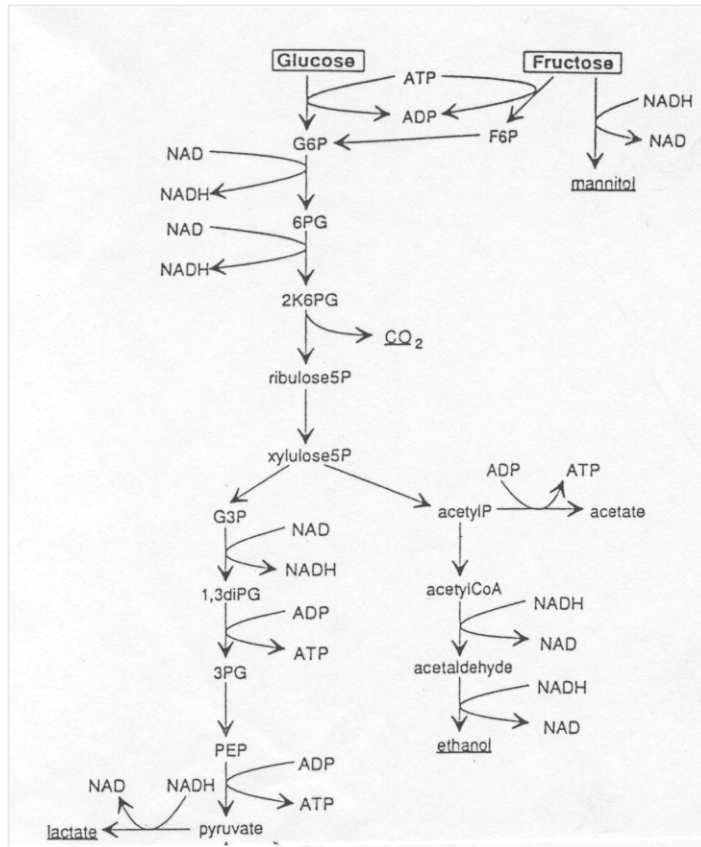

Figure 4. Schematic representation of carbon and energy flows through the central metabolic pathways of *L. mesenteroides*. G6P, glucose 6-phosphate; F6P, fructose 6-phosphate; 6PG, 6-phosphogluconate; 2K6PG, 2-keto-3-deoxy-6-phosphogluconate; G3P, glyceraldehydes-3-phosphate; acetylphosphate; 1,3diPG, 1,3-diphosphoglycerate; acetylCoA, acetyl coenzyme A; 3PG, 3-phosphoglycerate; PEP, phosphoenolpyruvate (Adapted from Salou *et al.* 1994).

and especially the high cost of the cofactor NAD(P)H (Kulbe *et al.*, 1988). *Leuconostoc mesenteroides* is capable of using fructose as an alternative electron acceptor, reducing it to mannitol (Soetaert *et al.*, 1995). Mannitol was found as one of major end products in our *Leuconostoc* fermentation. It would be necessary to separate the mannitol from the oligosaccharides if they are to be used as bifidobacteria growth factors, because mannitol can be a carbon source. Its presence would hinder studies on the effect of oligosaccharides on intestinal microflora. Bart *et al.* (1996) conducted separation of mannitol from a mixture of fructose and sorbitol using a continuous chromatographic separation method. However, there have been no attempts to separate mannitol from oligosaccharides

## **6. Starch Digestion and Intestinal Microflora**

Starch is one of the most available fermentable sources of energy for organisms and makes up 60 – 70% of dietary carbohydrate of humans (Gray, 1970). Starch is a glucose polymer, composed of amylose ( $\alpha$ -1,4 linked glucosyl linear chains of an average molecular weight (M.W.) of 100 kDa (~600 glucose units) and amylopectin (an  $\alpha$ -1,4 and  $\alpha$ -1,6 branched linked glucose polymer, -linked (M.W. 1000 kDa, ~6000 glucose units) (Gray, 1992).

In humans, a secreted pancreatic  $\alpha$ - amylase cleaves starch to a di- (maltose), tri- (maltotriose), and branched  $\alpha$ -dextrins in the duodenal cavity. Because there is no integral transport process in the intestinal enterocyte that can accommodate anything larger than free glucose, these oligosaccharides are further processed to glucose in the intestinal surface membrane by  $\alpha$ -glucosyl saccharidases. These enzymes are a large glycoprotein component of the intestinal surface brush border membrane. They contain enzymes such as sucrase,  $\alpha$ -dextrinase, and glucoamylase (Gray, 1991). Glucose then may be cotransported into the enterocyte, along with  $\text{Na}^+$ , either by a 75kDa specific integral brush border glucose carrier

or by a transporter expressed in the small intestine (Hediger *et al.*, 1987). Almost all of the free glucose is transported into the enterocyte (Smithson *et al.*, 1981). Digestion ranges for dietary carbohydrates varies by food type, for example, 81% for baked beans, 90% for whole oats, and 99% for rice (Levitt *et al.*, 1987). The digestion differences are attributed to the presence of  $\alpha$ -amylase inhibitors in food, or different rates of wetting of the starch components from the depths of the grain or legume, or to the presence of non-digestible carbohydrates (dietary fibers). However, a proportion of the unprocessed amylose and amylopectin passes all the way through the intestine to the colon where it can be metabolized by intestinal microflora (Gary, 1991).

The microflora is similar to that of the feces, where anaerobic bacteria comprise more than 90% of all the organisms present. In adults, *Bacteroides* and bifidobacteria are dominant groups followed by *Eubacteria*, *Peptostreptococci*. The most numerous bacterial species include: *Bifidobacterium adolescentis* and *Bifidobacterium longum*, *Bacteroides fragilis*, *Peptostreptococcus productus*, *Eubacterium aerofaciens* and *Ruminococcus bromii*. Many other organisms occur in small groups such as *Ruminococci* and *Clostridia*, *Staphylococci*, aerobic sporeformers, yeast and *Proteus* (Rasic and Kurmann, 1983). These bacteria all compete for the unprocessed starch molecules that reach the large intestine. Most of *Bacteroides* and *Enterobacteriaceae* rapidly utilize starches as carbon sources whereas utilization of starch by Bifidobacteria varies depending on the species (Krieg and Holt, 1984; Sneath *et al.*, 1984; Crittenden *et al.* 2001).

## **7. Potential Applications**

Antibiotic-associated gastrointestinal disturbances are a well-recognized problem. Antibiotic or drug therapy can significantly affect the bifidobacteria balance in the intestine

(Alestig *et al.*, 1983; O'Sullivan and Kullen, 1998). Restoring this balance rapidly is considered necessary to reduce the possibility of intestinal pathogens increasing in numbers and becoming established. Some studies have reported that ingesting bifidobacteria can help the restoration process (Korshunov *et al.*, 1985). Black *et al.* (1991) observed that *B. longum*, delivered with *Lactobacillus acidophilus*, decreased the incidence of ampicillin-associated diarrhea, the time required for recolonization of the intestine, and the concentration of *Bacteroides* in the feces. Further, Colombel *et al.* (1987) have shown an alleviation of erythromycin associated diarrhea, by administration of yogurt containing *B. longum*. In addition to their therapeutic value in situations of antibiotic treatment, bifidobacteria can be effective at alleviating diarrhea caused by rotavirus-induced diarrhea in infants and appears to offer a promising treatment for this disorder (Duffy *et al.*, 1994; Saavedra *et al.*, 1994; Yasui *et al.*, 1995; O'Sullivan and Kullen, 1998). Apart from oligosaccharide usage in foods, oligosaccharides have application in animal feeds. With the rise in antibiotic resistance and the subsequent removal of antibiotics from animal feed there is a need for alternatives that can reduce the incidence of *Salmonella enterica* and pathogenic *Escherichia coli* in animals. However, appropriate models are needed (Naughton *et al.*, 2001). There are an increasing number of reports of antibiotic-resistant infections in humans that can be transferred from the food supply attributed to the use of drugs on livestock and poultry.

During recent years, poultry production and consumption have continuously increased. The production of broilers increased from 9,482,000 tons in 1992 to 14,017,000 tons in 1996 in the United States (Olentine, 1997). Poultry is a carrier of numerous bacteria, including *Salmonella* and *Campylobacter*, which are causes of food-borne outbreaks.



Practical experience has demonstrated that it is difficult to reduce the percentage incidence of *Salmonella* on chickens below that already on the outside surface of chickens when they arrive at the processing plant. Significant reduction in *Salmonella* on processed broiler carcasses will require the delivery of *Salmonella* –reduced chickens to the processing plant. One of possible ways to control *Salmonella* levels can be the addition of selected carbohydrates to the diet of chickens. Mannose, or lactose in the diet of chickens has been reported to reduce *Salmonella* colonization (Oyofe *et al.*, 1989). Fructooligosaccharides (FOS) have been shown to influence intestinal bacterial populations by enhancing the growth of lactic acid bacteria such as *Lactobacillus* species and *Bifidobacteria* (Bailey *et al.*, 1991). Fukata *et al.* (1999) reported the inhibitory effects of fructooligosaccharides on *Salmonella* colonization of chicks. The mean number of *Salmonella enteritidis* in the chicks of the fructooligosaccharide group was significantly ( $P<0.05$ ) decreased compared with the control group.

The aims of the present research are 1) to develop an industrial production method for oligosaccharides and mannitol using a *L. mesenteroides* ATCC 13146 fermentation with sucrose and maltose and 2) to demonstrate the effectiveness of these oligosaccharides as prebiotics for poultry.

## MATERIALS AND METHODS

### 1. Organism, Culture Medium, and Inoculum Preparation

All strains of bacteria used in this study were obtained from the American Type Culture Collection (ATCC, Manassas, VA). They were maintained on agar slants, at 4°C and transferred monthly. Anaerobes were subcultured weekly. *Salmonella typhimurium* ATCC 14028 and *Escherichia coli* B ATCC 23226 were maintained on tryptic soy agar (Difco, Detroit, MI). *Bifidobacterium bifidum* ATCC 35914, *Bifidobacterium longum* ATCC 15708, *Lactobacillus johnsonii* ATCC 33200 and *Leuconostoc mesenteroides* ATCC 13146 were maintained anaerobically on *Lactobaccilli* MRS slants (Difco, Detroit, MI) containing 0.05 % (w/v) cystein. Chicken ceca were kindly supplied by Dr. Siragusa, G. (USDA ARS, Russell Res. Ctr., Athens, GA). Screening and isolation for chicken ceca bacteria were conducted following the method described by Hartemink and Rombouts (1999). Basically, ceca (from 6 weeks to 8 weeks broilers) in a plastic bag, were homogenized by kneading the bag and a subsample of ~ 10 g was transferred to a preweighed glass container containing 90 ml anaerobic buffered peptone water (Oxoid) with 0.5 g/L L-cystein-HCl. The container was then closed and weighed to determine the actual sample size. Mixed samples were diluted further with reduced physiological salt solution (rps, peptone 1 g/L, L-cystein-HCl 0.5g/L and NaCl 8g/L) or test media (MRSB). Finally, the samples were plated on the media and incubated at 37°C for 48 h. Unless otherwise stated, mixing, diluting, plating and incubation were carried out anaerobically. Six colonies out of the hundreds were selected randomly and designated as chicken ceca bacterium #1 to #6.

## **2. Preparation of Oligosaccharides**

Batch fermentations were conducted in a 2-L BioFlo II fermentor (New Brunswick Scientific Co.) with a working volume of 1.0 L. The media had the following composition: sucrose (100g/L); maltose (50g/L); yeast extract (5g/L);  $\text{MgSO}_4 \cdot 7\text{H}_2\text{O}$  (0.2g/L);  $\text{FeSO}_4 \cdot 7\text{H}_2\text{O}$  (0.01g/L); NaCl (0.01g/L);  $\text{MnSO}_4 \cdot 7\text{H}_2\text{O}$  (0.01g/L);  $\text{CaCl}_2$  (0.05g/L);  $\text{KH}_2\text{PO}_4$  (3g/L) with pH 7.2. Fermentors were inoculated from late log phase flask cultures at 1.0% of working volume. Fermentations were conducted at pH 6.5, 28°C, and 200 rpm. After harvesting, cells were removed by centrifugation at 10,400 x g for 20 min (Dupont Sorvall RC5C, Newtown, CT). Activated charcoal (5g/L, Sigma Chem. Co., St. Louis, MO) and Celite 545 (1g/L, Fisher Scientific, Fair Lawn, NJ) were added to cell-free culture broth and mixed at 50°C for 20 min. The broths were then filtered through No. 6 filter paper (Whatman International Ltd., Maidstone, England) to remove the carbon. The filtered broths were desalted using ion-exchange columns filled with an anion-exchange resin in the hydroxide form and a cation-exchange resin in the hydrogen form (Rohm and Haas, Philadelphia, PA). The eluents were concentrated by vacuum evaporation (Brinkmann Instrument Inc., Westbury, NY) to 65 % solids. Mannitol crystallized upon cooling the concentrates and was removed by decantation. Oligosaccharides were separated from the mannitol free concentrates using a cation exchange column (in calcium form); the oligosaccharide fractions were concentrated by vacuum evaporation.

## **3. Analytical Methods**

Bacterial growth was measured by turbidimetry at 650 nm, calibrated against cell dry weight. Cells from a known volume were harvested by centrifugation at 10,400 x g, for 2 min (Dupont Sovall 24S, Newtown, CT), washed with deionized water, resuspended in a

minimum volume of water, and dried (initially overnight at 95 °C and then at 105 °C) to constant weight. An absorbance of 1.0 at 660nm was equivalent to 0.51g of dry matter·liter<sup>-1</sup>.

- TLC – Separation and qualitative identification of oligosaccharides was conducted using TLC. Whatman K6F silica gel plates of sizes (10 × 20 cm) were obtained from Fisher Scientific (Chicago, IL). A homologous series of isomaltodextrins (DP 1-10) was kindly donated by Dr. Doman Kim (Chonnam National Univ., Kwangju, Korea). Maltopentaose, maltohexaose, maltoheptaose, pannose, and isomaltotriose (Sigma Chem. Co., St. Louis, MO) were used as standards. Aliquots (1-2 µL) of the solutions to be analyzed were applied 20 mm from the bottom of the TLC plates with 10 µL microsyringe pipets. The plates were developed at ambient temperature, using a mixture of solvents (acetonitrile, ethylacetate, propanol, and water in volume (mL) proportions of 85: 20: 50: 70). After development was complete, the plates were dried, the carbohydrates visualized using a spray of an ethanol solution containing 0.3 % (w/v)  $\alpha$ -naphthol and 5 % (v/v) H<sub>2</sub>SO<sub>4</sub>. After air-drying, spots were developed by heating in an oven for 10 to 20 mins at 100°C. Glucooligosaccharides were identified by comparing their chromatographic behavior with those of the standards.

- Cation column tests – Different types of cation resins (Na, K, Ca form) were tested for separation of oligosaccharides from the end fermentation products. Resins (Duolite CR-1320, Rohm and Haas, Philadelphia, PA) in glass jacketed columns (10 mm (Inner diameter) × 100 mm (Length), working volume 70 ml ) were regenerated using 5% solutions of NaCl, KCl, or CaCl. Temperature of the water eluent and the circulating water for glass jacket were 92 and 80 °C, respectively, and no pressure on the column was applied. Injection volume was 1 ml of solution (15 Brix° GOS). The detector was a differential refractometer (Waters).

- High-performance ion chromatography using a CarboPac MA1 column (Dionex, Sunnyvale, CA) and a pulsed amperometric detector (PAD, Dionex) was used to analyze for quantitative analysis of glucose, fructose, sucrose, mannitol and maltose concentrations in solution. The samples were eluted at  $0.4 \text{ ml}\cdot\text{min}^{-1}$  with a  $0.48 \text{ M}$  NaOH solution. Oligosaccharide concentrations were calculated from peak areas of high-performance liquid chromatography on an Aminex-HPX-87K Bio-Rad column (Bio-Rad Lab. Hercules, CA) run at  $85 \text{ }^\circ\text{C}$  with  $\text{K}_2\text{HPO}_4$  as eluent, at a constant flow rate of  $0.5\text{ml}\cdot\text{min}^{-1}$ , using glucose as a standard.
- $^{13}\text{C}$  NMR – The oligosaccharides (DP 1 to DP 8) were analyzed using a DPX 250 (63 MHz  $^{13}\text{C}$ ) system with help of Mr. Yang, J. (Dept. of Chemistry, LSU). The chemical shifts were expressed in ppm relative to the methyl signal of acetone in deuterium oxide solvent which was used as an internal standard at  $\delta = 29.92 \text{ ppm}$ . The various signals were assigned as described by Seymour *et al.* (1976a) and Remaud *et al.* (1992).
- Kinetic assay for  $\alpha$ -glucosidase –  $\alpha$ -glucosidase (maltase; EC 3.2.1.20),  $\beta$ -NAD, glucose dehydrogenase (EC 1.1.147) and other reagent chemicals were obtained from the Sigma Chemical Co. (St. Louis, MO). The kinetic assays were based on the following reaction;

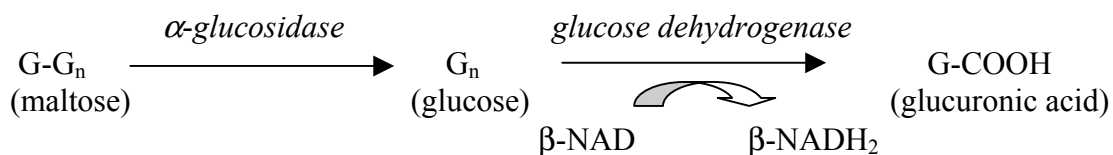

The kinetic assays were all performed in 96-well plates and read at wavelength 320 nm in a SPECTRAMax Plus microtiter plate reader (Molecular Devices Corp., Sunnyvale, CA) at  $37^\circ\text{C}$ . Their software package Softmax™ was used for data analysis.  $\alpha$ -Glucosidase (maltase; EC 3.2.1.20),  $\beta$ -NAD, and glucose dehydrogenase (EC 1.1.147) solutions were

prepared with 0.1M K<sub>2</sub>HPO<sub>4</sub> (pH 7) buffer. Each well contained 25µl of 0.13 IU/ml glucose dehydrogenase, 25µl of 1.65 IU/ml of α-glucosidase, and 20µl of 12 mM of β-NAD in a total volume of 200µl with different combinations of sugars and 0.1M K<sub>2</sub>HPO<sub>4</sub> (pH 7) buffer. Absorbance change with time was measured at 320nm.

#### **4. Oligosaccharide Utilization by Selected Microorganisms**

The growth of selected bacteria in the presence of oligosaccharides was compared by measuring absorbances over time at 660 nm. The media used for both the *Bifidobacteria* sp. and *L. johnsonii* was of the same composition as *Lactobacillus* MRS broth with 0.05 % (w/v) cystein, except the carbon source was replaced by various oligosaccharide preparations. The growth media for *S. typhimurium* and *E. coli* was tryptic soy broth, with the carbon source replaced by various oligosaccharide preparations. Carbon sources were supplied at a final concentration of 0.5 % (w/v). All carbon sources were filter sterilized (0.2 µm). The following carbon sources were compared: glucose (Sigma Chem Co., St. Louis, MO), commercial fructooligosaccharides (FOS; > 97.5 %, Samyang Genex Co., Seoul, Korea), and oligosaccharide preparations. Individual culture, anaerobic growth tests were conducted in sealed glass test tubes. Each tube was inoculated from an overnight culture with either *S. typhimurium* or *E. coli* and a 24 to 48 hr culture of a *Bifidobacteria* sp. or *L. johnsonii*. The experiments with *Bifidobacteria* sp. and *L. johnsonii* were conducted under anaerobic conditions using anaerobic jars (BBL Microbiology Sys., Cockeysville, MD) or the Oxyrase plate system (Oxyrase, Inc., Mansfield, OH). MRS broth containing 0.05 % (w/v) cystein with oligosaccharides as a carbon source was used for mixed cultures of *S. typhimurium* and *L. johnsonii*. Total viable counts were conducted on MRS agar and the cell numbers of *S. typhimurium* were determined from growth on MacConkey agar plates (Difco,

Detroit, MI). The cell numbers for *L. johnsonii* were obtained as the difference between total viable count and *S. typhimurium* numbers. TLC was used to determine oligosaccharide consumption patterns of various strains. The media was MRSB for Bifidobacteria and ceca bacteria and TSB for *S. typhimurium* and *E. coli* containing 0.5% (w/v) of *Leuconostoc* glucooligosaccharides instead of glucose as the carbon source. Media pH was adjusted to 6.0 and 0.1% (v/v) inoculum grown overnight in MRSB was used. During the growth, samples were taken at various times. Samples (2  $\mu$ l) were applied on TLC plates.

## RESULTS

### 1. Oligosaccharide Production

- Glucooligosaccharide (GOS) production by acceptor reaction

GOS production was complete by late log phase, about 10 hr post-inoculation, and levels did not drop thereafter (Figure 5). Sucrose disappeared rapidly during log phase of growth, with sucrose depletion corresponding to the transition point to stationary phase. Once sucrose was depleted, the accumulated fructose was metabolized to mannitol with a decrease in growth rate compared to growth on sucrose. Fructose concentration peaked about the end of log phase then decreased slowly. Mannitol production occurred through the lag phase to the stationary phase and was linked to the fructose concentration where the rate of fructose disappearance was the inverse of the rate of mannitol formation. Oligosaccharide production was associated with cell growth. The conversion of fructose to mannitol was associated with the accumulation of fructose. Upon completion of fermentation, the cell mass was 3.2g/L. The weight % yield of oligosaccharide ( $\text{product produced} \times 100 / [(160 \times \text{mole of sucrose consumed}) + (342 \times \text{mole of maltose consumed})]$ ) was 82 % of theoretical, the number 160 in the equation from  $342 (\text{sucrose M.W.}) - ((180 (\text{fructose M.W.}) + 2 (\text{hydrogen M.W.}))$  and the conversion of fructose to mannitol was 71 % of theoretical. Thin layer chromatography (TLC) clearly showed the course of GOS production (Figure 6). As fermentation proceeded, mono- and disaccharides disappeared as the higher DP polysaccharides were formed. By 24 hr, all mono- and disaccharides had been converted to higher oligosaccharide polymers. Four main oligosaccharides were found. The sizes of these oligomers were compared with a commercial oligosaccharide product of known composition. The *Leuconostoc* oligosaccharides were branched polymers with a size range of DP 1 to 7. The



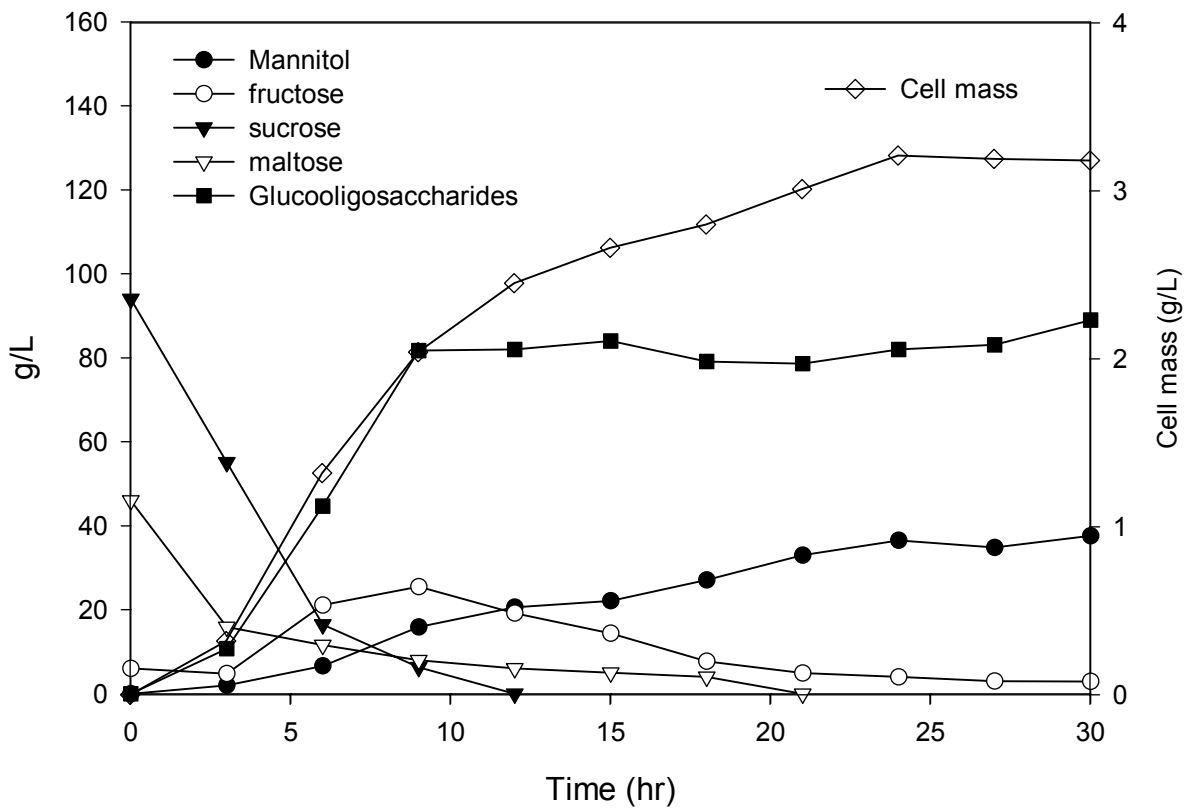

Figure 5. Glucooligosaccharide production by *L. mesenteroides* ATCC 13146 from sucrose (10 % w/v) and maltose (5% w/v) as a function of time.

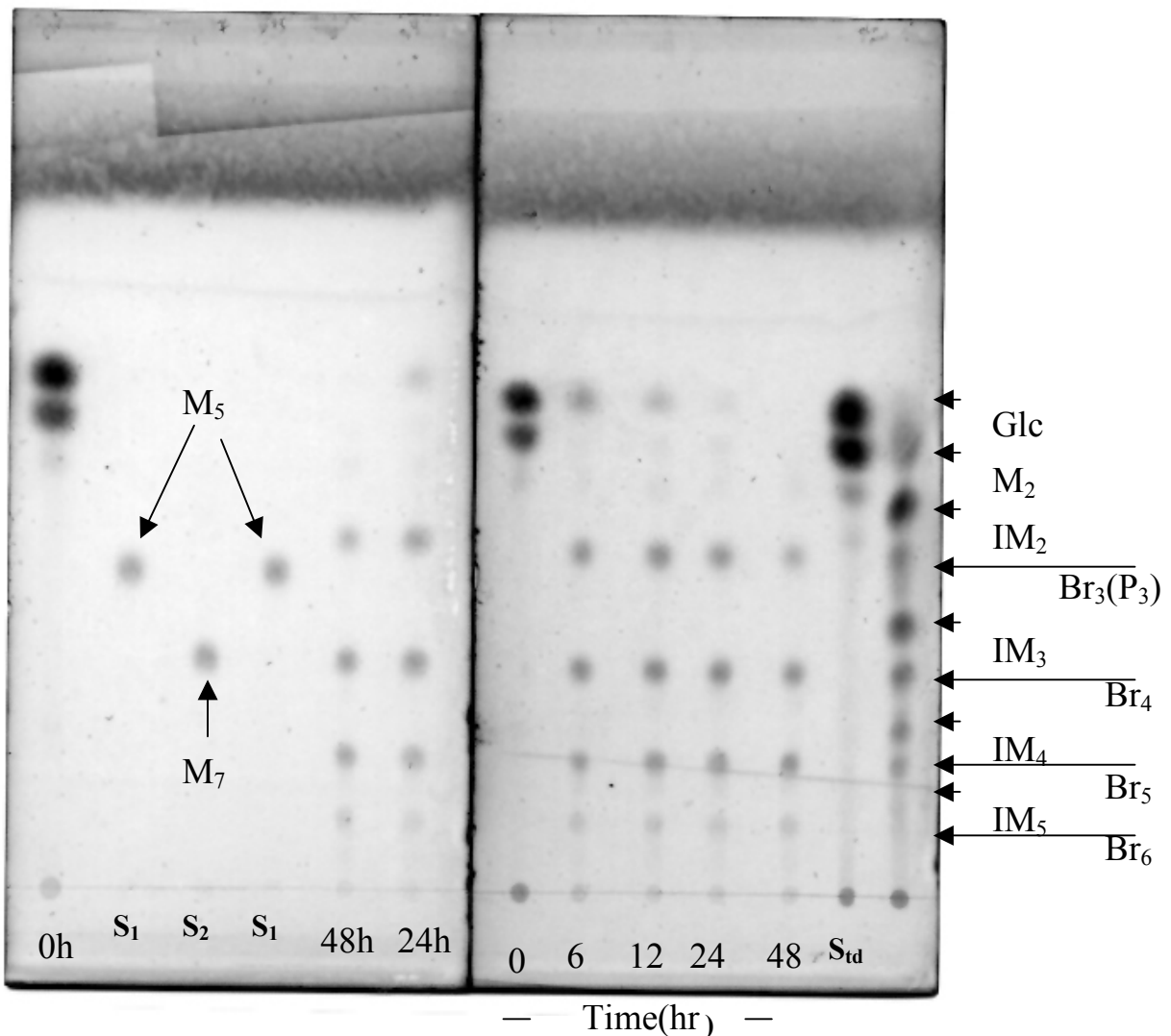

Figure 6. TLC of glucooligosaccharide production as a function of time. S<sub>1</sub>, maltopentaose standard; S<sub>2</sub>, maltoheptaose standard; Std, a mixture of glucose and maltose; C, Commercial isomaltooligosaccharides (Wako Pure Chemical Industry Ltd., Osaka, Japan); Glc, glucose; M<sub>2</sub>, maltose; IM<sub>2</sub>, isomaltose; Br<sub>3</sub>(P<sub>3</sub>), panose; IM<sub>3</sub>, isomaltotriose; Br<sub>4</sub>, branched DP4; IM<sub>4</sub>, isomaltotetraose; Br<sub>5</sub>, branched DP5; IM<sub>5</sub>, isomaltopentaose; Br<sub>6</sub>, branched DP6; M<sub>5</sub>, maltopentaose; M<sub>7</sub>, maltoheptaose. The solvent system was a mixture of acetonitrile, ethylacetate, propanol, and water (in volume (mL) proportions of 85: 20: 50: 70). After development was complete, the plates were dried and the carbohydrates visualized using a spray of an ethanol solution containing 0.3 % (w/v)  $\alpha$ -naphthol and 5 % (v/v) H<sub>2</sub>SO<sub>4</sub>. Samples were taken at the indicated times during fermentation.

oligosaccharides, based on their linkages, showed different R<sub>f</sub> values (Figure 7). As indicated by Robyt and Mukerjea (1994), the migration of branched isomaltodextrins containing single  $\alpha$ -1,3 or  $\alpha$ -1,4 linkages, is faster than equivalent dextrans containing only  $\alpha$ -1,6 linkages. The migration of the *Leuconostoc* oligosaccharides was faster than equivalent isomaltodextrins ( $\alpha$ -1,6 linkages), but slower than equivalent maltodextrins ( $\alpha$ -1,4 linkages).

- Oligosaccharide separation

The fermentation broth, after cell separation, contained oligosaccharides, mannitol and some organic acids. Because the oligosaccharides are neutral polymers, and the other components (acids, color compounds and salts) are charged, cation resins were used for separation of oligosaccharides. Neither K<sup>+</sup> nor H<sup>+</sup> cation columns clearly separated the oligosaccharides from the mannitol and other products whereas Ca<sup>2+</sup> cation columns produced two well separated peaks (Figure 8). The first peak contained all the oligosaccharides and the second peak did mannitol and organic acids (Figure 9). In the second peak, there were acetic acid and lactic acid. Based on these results, the process for producing an oligosaccharide product was developed (Figure 10).

- Mannitol separation

Crystallization at 4 °C separated most of mannitol from oligosaccharides (Figure 11). Mannitol harvested showed high purity (> 99.0 %, calculated by HPLC peak area). A crude oligosaccharide mixture can be obtained after crystallization. Using a cation exchange (Ca<sup>2+</sup> form) column, pure oligosaccharides mixture (> 98.8 % w/w, Figure 8) was obtained.

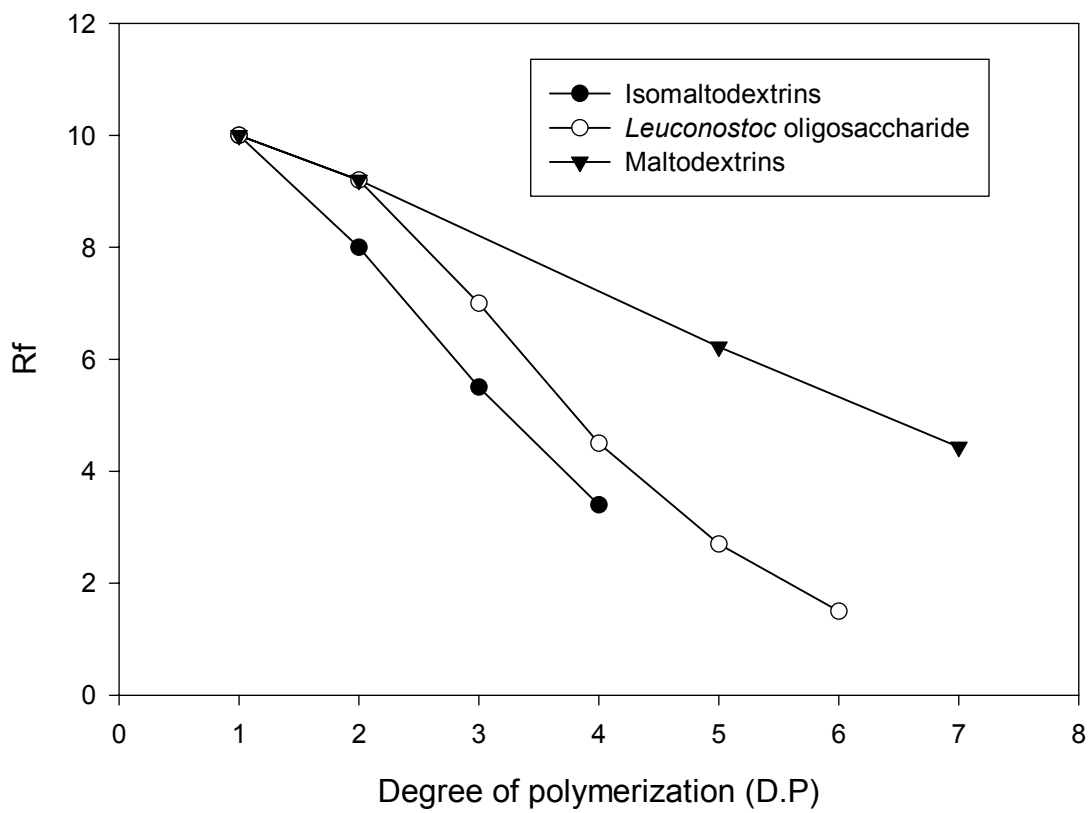

Figure 7. Rf values for oligosaccharides, taken from TLC plates based on linkages. Isomaltodextrins:  $\alpha$ -1,6 linkages, Maltodextrins:  $\alpha$ -1,4 linkages

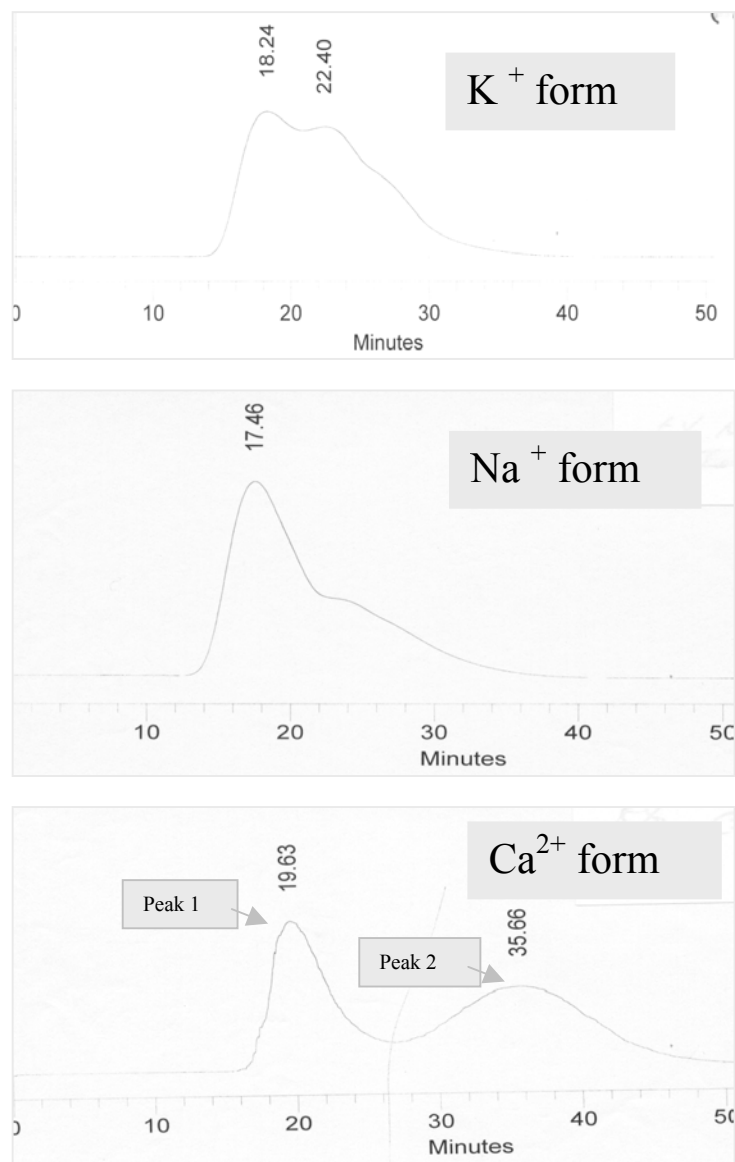

Figure 8. Profiles of mannitol/oligosaccharide separation on different cation resins. Resins (Duolite CR-1320, Rohm and Haas, Philadelphia, PA) in glass jacketed columns (10 mm (Inner diameter)  $\times$  100 mm (Length), working volume 70 ml ) were regenerated using 5% solutions of NaCl, KCl, or CaCl. Temperature of the water eluent and the circulating water for glass jacket were 92 and 80  $^{\circ}$ C, respectively, and no pressure on the column was applied. The detector was a differential refractometer (Waters).

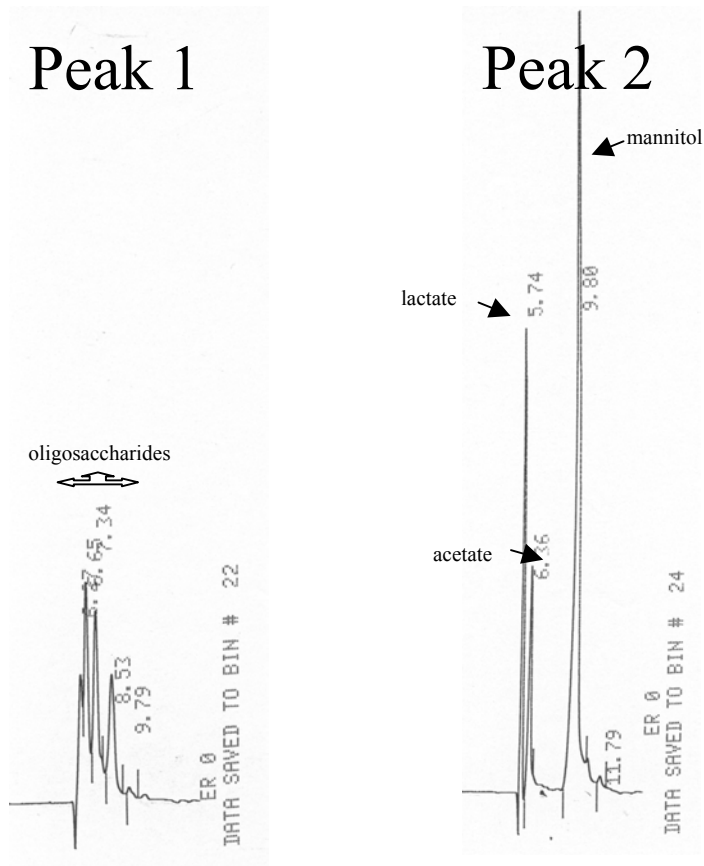

Figure 9. HPLC chromatogram of the peaks fractionated by  $\text{Ca}^{2+}$  cation resin columns. Fractions were collected from the outlet of glass jacket column as a time function. Each of the fractions was analyzed on an Aminex-HPX-87K Bio-Rad analytical column (Bio-Rad, Hercules, CA) run at  $85\text{ }^{\circ}\text{C}$  with  $\text{K}_2\text{HPO}_4$  as eluent, at a constant flow rate of  $0.5\text{ml}\cdot\text{min}^{-1}$ .

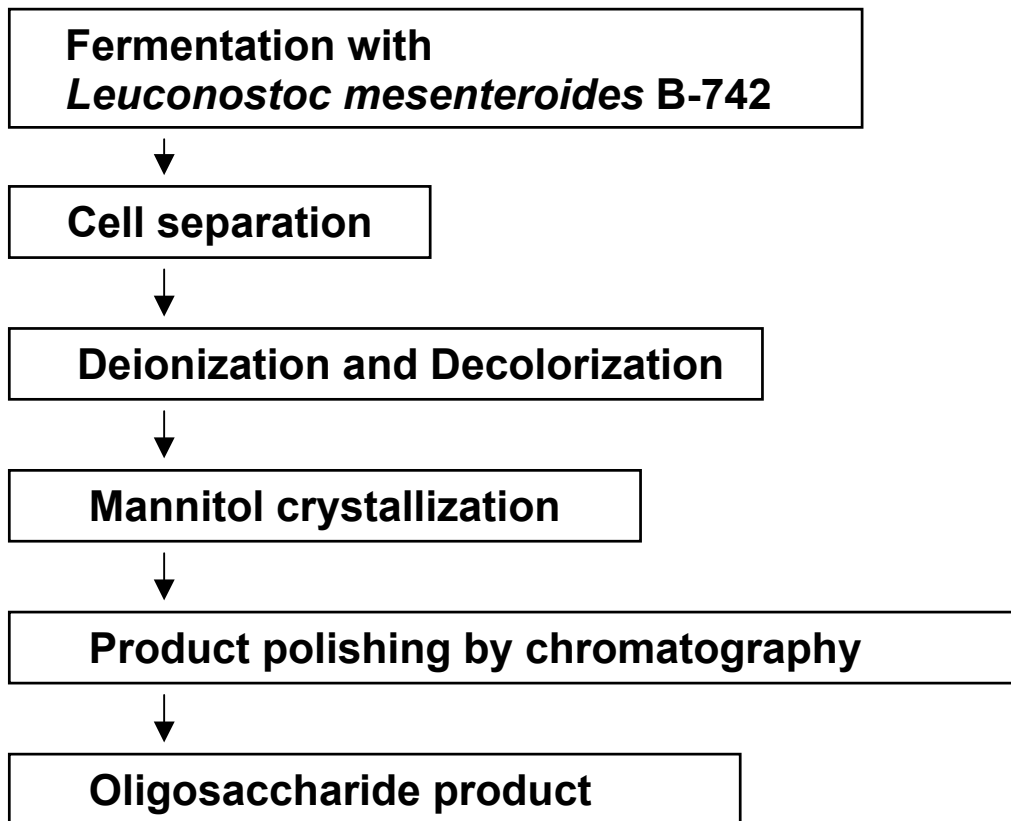

Figure 10. Flow chart for glucooligosaccharide production.

Cell separation was done by centrifugation at  $10,400 \times g$  for 20 min. Deionization and decolorization was done by ion-exchange. Anion-exchange resin was in hydroxide form and cation-exchange resin was in hydrogen form. Mannitol crystallized out at  $4^{\circ}\text{C}$ .  $\text{Ca}^{2+}$  cation resin was used for removing residual impurities.





Pure oligosaccharide solution (14.5 Brix°) was concentrated to 60 Brix° by evaporation. The concentrated pure oligosaccharides (ca. 60 % w/v) were used for the further testing (Table 4).

- Composition and structure of oligosaccharide products



Thin layer chromatography showed that GOS were branched polymers ranging in size from DP 2 to 7 (Figure 12). By HPLC peak area, there was 6.9% DP 2, 28.4% panose, 36.7% branched DP 4, 19.1% branched DP5, 7.4% branched DP6, and 1.2% branched DP7. In the pure form, there was only a trace amount of monosaccharides (< 0.2 %) present and no polysaccharides larger than DP 7. Structural analysis of GOS by C<sup>13</sup> NMR showed that the GOS are linked mainly by  $\alpha$ -1,4 and  $\alpha$ -1,6 linkages (Figure 13). Two closely separated peaks at 100.44 ppm,  $\alpha$ -1,4, that are for specific residues are also encountered in the spectrum of maltose and both correspond to a glucose molecule linked to a reducing residue of maltose by an  $\alpha$ -1,4 linkage (Remaud *et al.*, 1992). It also implies that the  $\alpha$ -1,4 linkage is located at the reducing end of isomaltosyl residues containing  $\alpha$ -1,6 linkages. The peaks corresponding to the region of 98.0- 99.0 ppm show  $\alpha$ -1,6 linked residues. However, The intensity of the resonances for  $\alpha$ -1,3 bonds around 100.0 and 80.6- 81.2 ppm were not present (Dols *et al.*, 1998; Remaud *et al.*, 1992).

## 2. Glucooligosaccharides as Microbial Growth Modifiers

- Individual cultures

Growth of selected bacteria on *L. mesenteroides* ATCC 13146 glucooligosaccharides as a carbon source was compared with growth on a commercial fructooligosaccharide (FOS) mixture. Both types of oligosaccharides produced significantly reduced growth of *S. typhimurium* and *E. coli* compared with growth on glucose (Table 5). Based on the TLC

Table 4. Product yields and process for production of glucooligosaccharides

Process	Components in process			
Fermentation	Input	Sucrose (10 % w/v)	100 g/L	
		Maltose (5 % w/v)	50 g/L	
		Yeast extract and salts	8.28 g/L	
				
	Output	Oligosaccharides	80.1 g/L (82.3 % <sup>a</sup> )	
		Mannitol	37.6 g/L (70.1% <sup>b</sup> )	
Acids, ethanol and cell mass		5.75 g/L		
Decolorization and deionization			Removal of color pigments and salts	
Evaporation			Concentrated to ca. 60 % (w/v)	
Crystallization			at 4°C	
	Oligosaccharides, residual mannitol	Mannitol (86.4% recovered, 99.0% purity)		
Ca <sup>2+</sup> Ion exchange				
	Purified oligosaccharides	98.8% purity		

a. Weight % yield of oligosaccharide (product produced × 100 / [(160 × mole of sucrose consumed) + (342 × mole of maltose consumed)])

b. % fructose conversion to mannitol

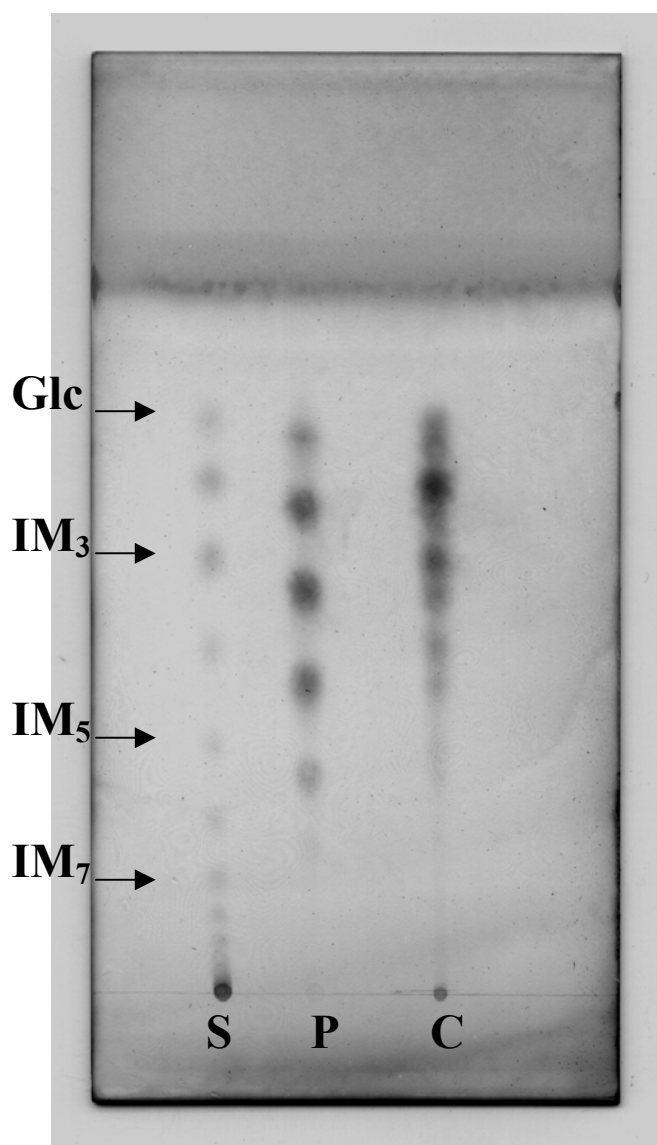

Figure 12. TLC of branched  $\alpha$ -glucooligosaccharides of *L. mesenteroides* (ATCC 13146). S, Isomaltodextrins; P, Glucooligosaccharide product; C, Commercial isomaltooligosaccharides (Wako Pure Chemical Industry Ltd., Osaka, Japan); Glc, glucose; IM<sub>3</sub>, Isomaltotriose; IM<sub>5</sub>, Isomaltopentaose; IM<sub>7</sub>, Isomaltoheptaose. The solvents system was mixture of acetonitrile, ethylacetate, propanol, and water (in volume (mL) proportions of 85: 20: 50: 70). After development was complete, the plates were dried, the carbohydrates visualized using a spray of an ethanol solution containing 0.3 % (w/v)  $\alpha$ -naphthol and 5 % (v/v) H<sub>2</sub>SO<sub>4</sub>.

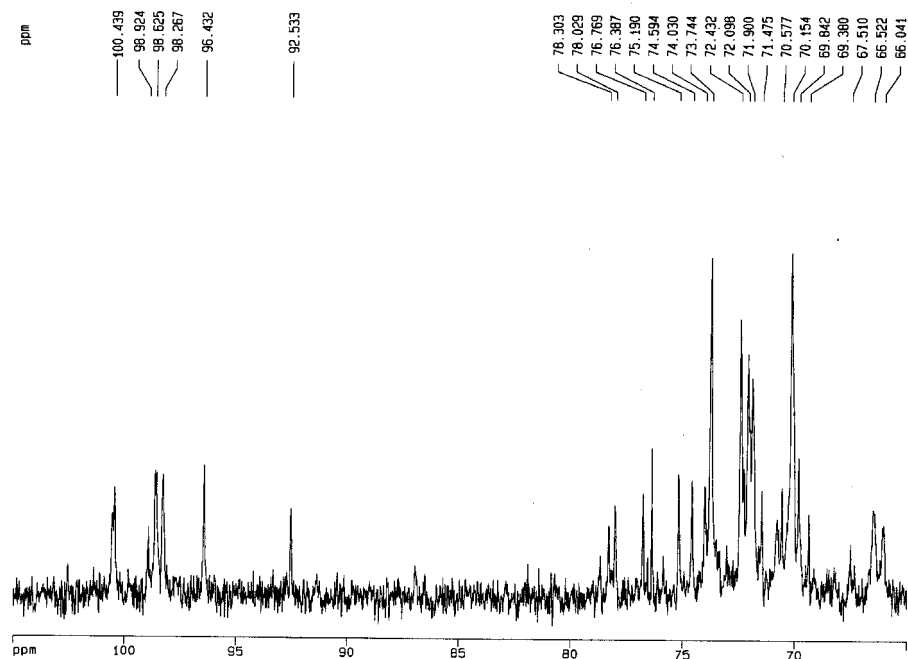

Figure 13.  $^{13}\text{C}$  NMR of *Leuconostoc* glucooligosaccharides. These oligosaccharides were analyzed using a DPX 250 (63 MHz  $^{13}\text{C}$ ) system. The chemical shifts are expressed in ppm relative to the methyl signal of acetone in a deuterium oxide solvent, which was used as an internal standard at  $\delta = 29.92$  ppm. The various signals were assigned as described by Seymour *et al.* (1976) and Remaud *et al.* (1992); 85- 105 ppm, the anomeric region (mainly 97- 103 ppm, as there is only an infinitesimal proportion of reducing sugar in any of the polymers); 70- 75 ppm, C-2,3,4, and 5; 60- 70 ppm, bonded and non-bonded C-6 atoms; 75- 85 ppm, signals of bonded C-2, C-3, C-4, C-5.

Table 5. Growth comparison on glucooligosaccharide preparations  
 GOS, *Leuconostoc* glucooligosaccharides; FOS, Commercial fructooligosaccharides  
 (Samyang Genex Co., Seoul, Korea)

Organism	Growth rate in exponential growth phase ([Absorbance unit×100]·hr <sup>-1</sup> )			Growth rate (on GOS/ glucose)
	glucose	GOS	FOS	
<i>S. typhimurium</i>	9.89	3.64	3.48	36.8
<i>E. coli</i>	9.35	2.68	2.44	28.7
<i>B. bifidum</i>	13.30	9.81	13.10	73.8
<i>L. johnsonii</i>	11.06	10.74	10.70	97.1
<i>B. longum</i>	11.72	11.69	11.70	99.7

analysis, these organisms could not use the glucooligosaccharides, efficiently (Figures 14, 15). There was no significant difference between growth rates on either of the oligosaccharide preparations. The growth rate suppression of *E. coli* in the presence of GOS was marginally greater than that of *S. typhimurium* (Table 5). The growth of selected probiotic strains on GOS was also compared. *Leuconostoc* GOS supported the growth of *Bifidobacterium longum* and *L. johnsonii* and showed no significant difference when compared to glucose as carbon source. *B. longum* degraded almost all components of the GOS within 24 hrs (Figure 16). Utilization of the GOS product by *B. bifidum* was less rapid (74.9 % relative to growth rate of FOS) than utilization of a commercial FOS and glucose. This indicates that the growth of probiotic strains was also dependent on the type of oligosaccharides.

- Mixed cultures

To test for prebiotic effects of the GOS, mixed cultures of *S. typhimurium* and *L. johnsonii* were grown on the oligosaccharides. When the medium pH was above 5.0, both organisms grew; however, *S. typhimurium* grew more slowly than *L. johnsonii*. As the population of *L. johnsonii* increased, the pH dropped (Figure 17). When the pH dropped below 5.0, *S. typhimurium* populations decreased, until they were below detection level (< 1).

- Growth of bacteria isolated from chicken ceca on GOS

Utilization of *Leuconostoc* GOS by six bacterial isolates (all showed Gram positive, catalase negative and lactic acid formation from glucose) from chicken ceca was compared to utilization of a commercial fructooligosaccharide (FOS), three of the six bacteria showed more growth after 24 hr on GOS than on FOS (Table 6). In mixed cultures of chicken ceca

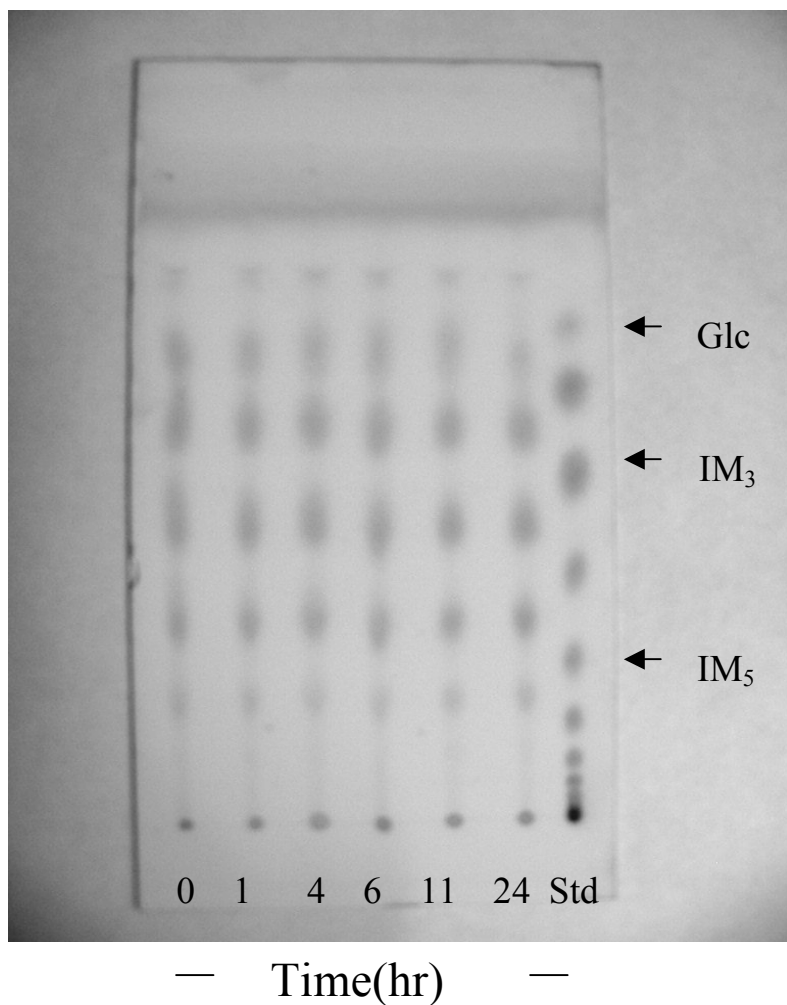

Figure 14. TLC of anaerobic growth of *E.coli* B (ATCC 23226) on 0.5% glucooligosaccharide preparations. Std, standard; Glc, glucose; IM<sub>3</sub>, isomaltotriose; IM<sub>5</sub>, isomaltopentaose. The solvent system was a mixture of acetonitrile, ethylacetate, propanol, and water (in volume (mL) proportions of 85: 20: 50: 70). After development was complete, the plates were dried and the carbohydrates visualized using a spray of an ethanol solution containing 0.3 % (w/v)  $\alpha$ -naphthol and 5 % (v/v) H<sub>2</sub>SO<sub>4</sub>.

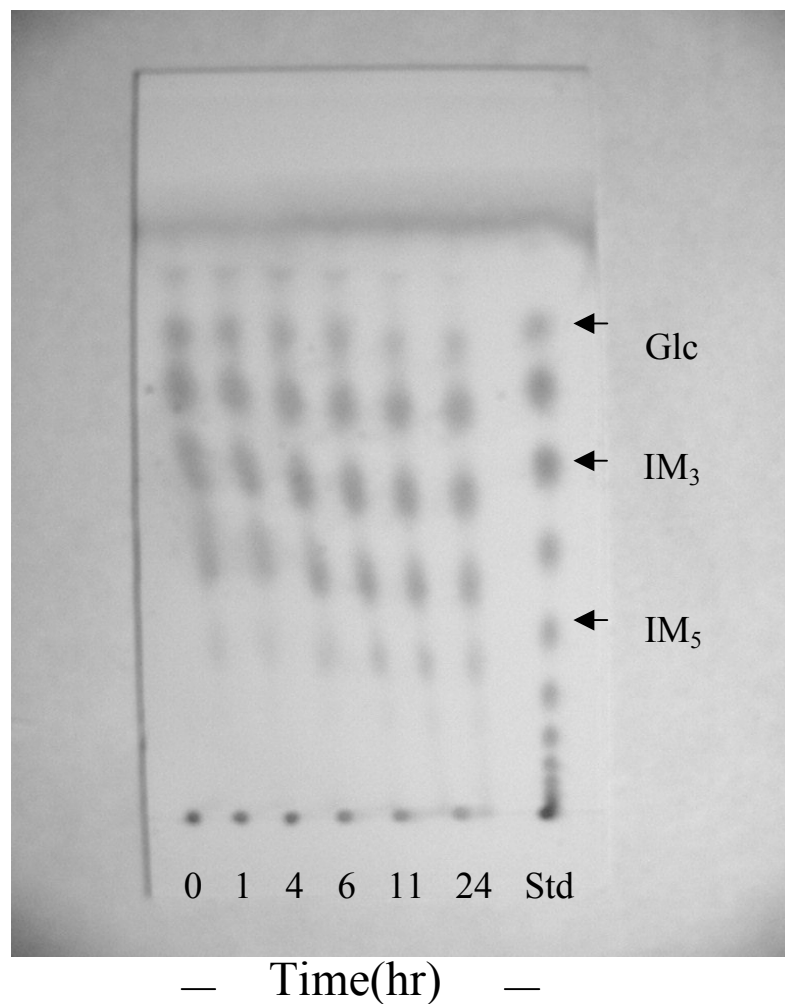

Figure 15. TLC of anaerobic growth of *Salmonella typhimurium* (ATCC 14028) on 0.5% glucooligosaccharide preparations. Std, standard; Glc, glucose; IM<sub>3</sub>, isomaltotriose; IM<sub>5</sub>, isomaltopentaose. The solvent system was a mixture of acetonitrile, ethylacetate, propanol, and water (in volume (mL) proportions of 85: 20: 50: 70). After development was complete, the plates were dried and the carbohydrates visualized using a spray of an ethanol solution containing 0.3 % (w/v)  $\alpha$ -naphthol and 5 % (v/v) H<sub>2</sub>SO<sub>4</sub>.



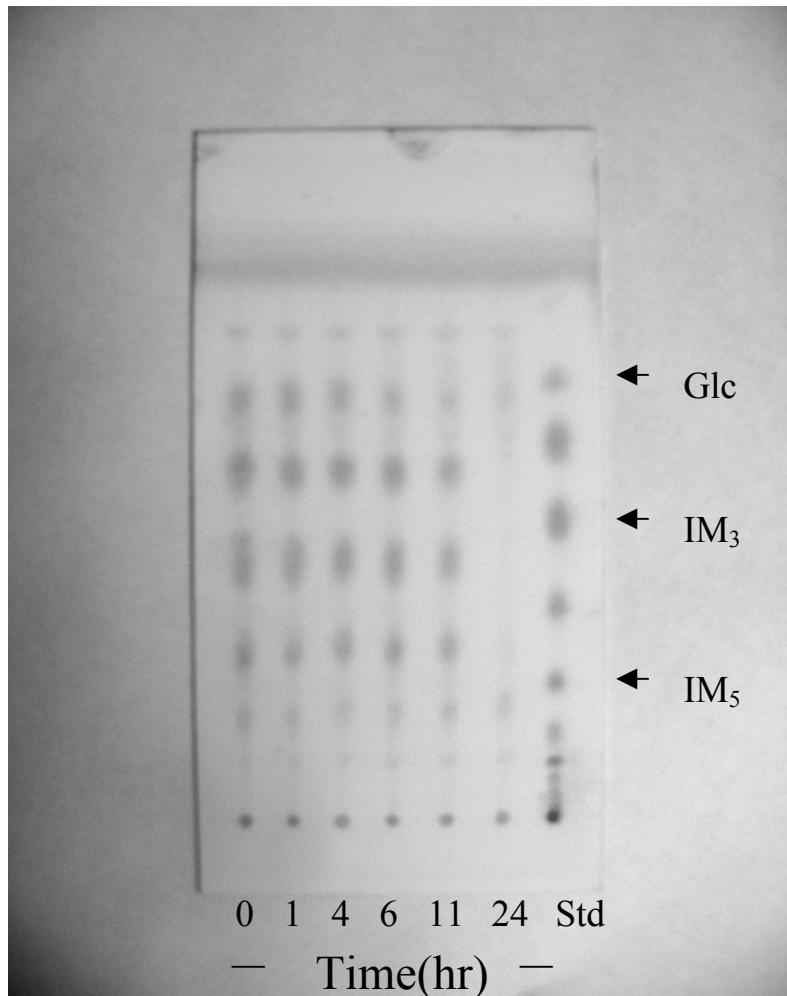

Figure 16. TLC of anaerobic growth of *Bifidobacterium longum* (ATCC 15708) on 0.5% glucooligosaccharide preparations. Std, standard; Glc, glucose; IM<sub>3</sub>, isomaltotriose; IM<sub>5</sub>, isomaltopentaose. The solvent system was a mixture of acetonitrile, ethylacetate, propanol, and water (in volume (mL) proportions of 85: 20: 50: 70). After development was complete, the plates were dried and the carbohydrates visualized using a spray of an ethanol solution containing 0.3 % (w/v)  $\alpha$ -naphthol and 5 % (v/v) H<sub>2</sub>SO<sub>4</sub>.

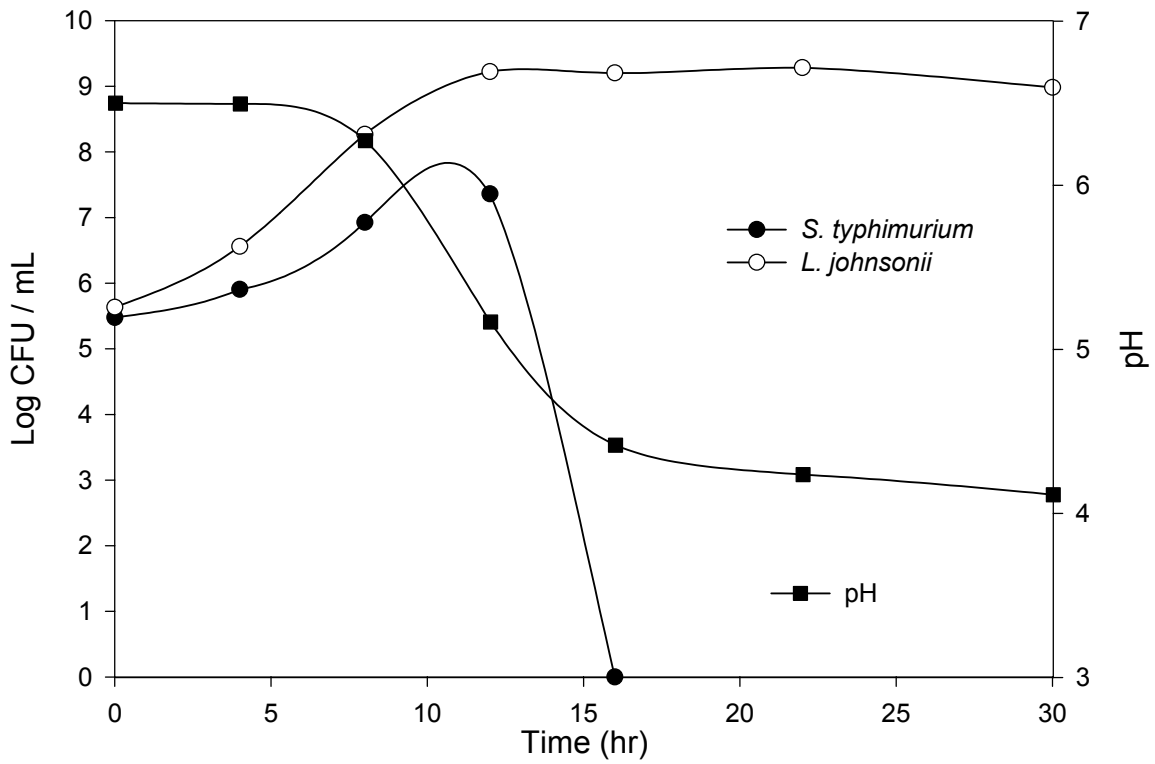

Figure 17. Anaerobic growth of mixed cultures of *S. typhimurium* and *L. johnsonii* on the glucooligosaccharide preparation at 37°C.

Table 6. Growth comparison of chicken ceca bacteria on the glucooligosaccharide preparations. GOS, *Leuconostoc* glucooligosaccharide; FOS, Commercial fructooligosaccharides (Samyang Genex Co., Seoul, Korea)

Organism	Relative growth to glucose as a carbon source at 24 hr incubation ([Absorbance unit of Glc at 24 hr/Absorbance unit of ×100]·hr <sup>-1</sup> )		
	glucose	GOS	FOS
C.B. # 1	100.00	22.77	61.20
C.B. # 2	100.00	99.34	79.29
C.B. # 3	100.00	75.85	48.01
C.B. # 4	100.00	36.72	61.40
C.B. # 5	100.00	87.23	50.25
C.B. # 6	100.00	87.17	87.66

<sup>a</sup>Growth level at stationary phase (at 24 hr) on glucose was calculated as 100. C.B.; Ceca Bacterium

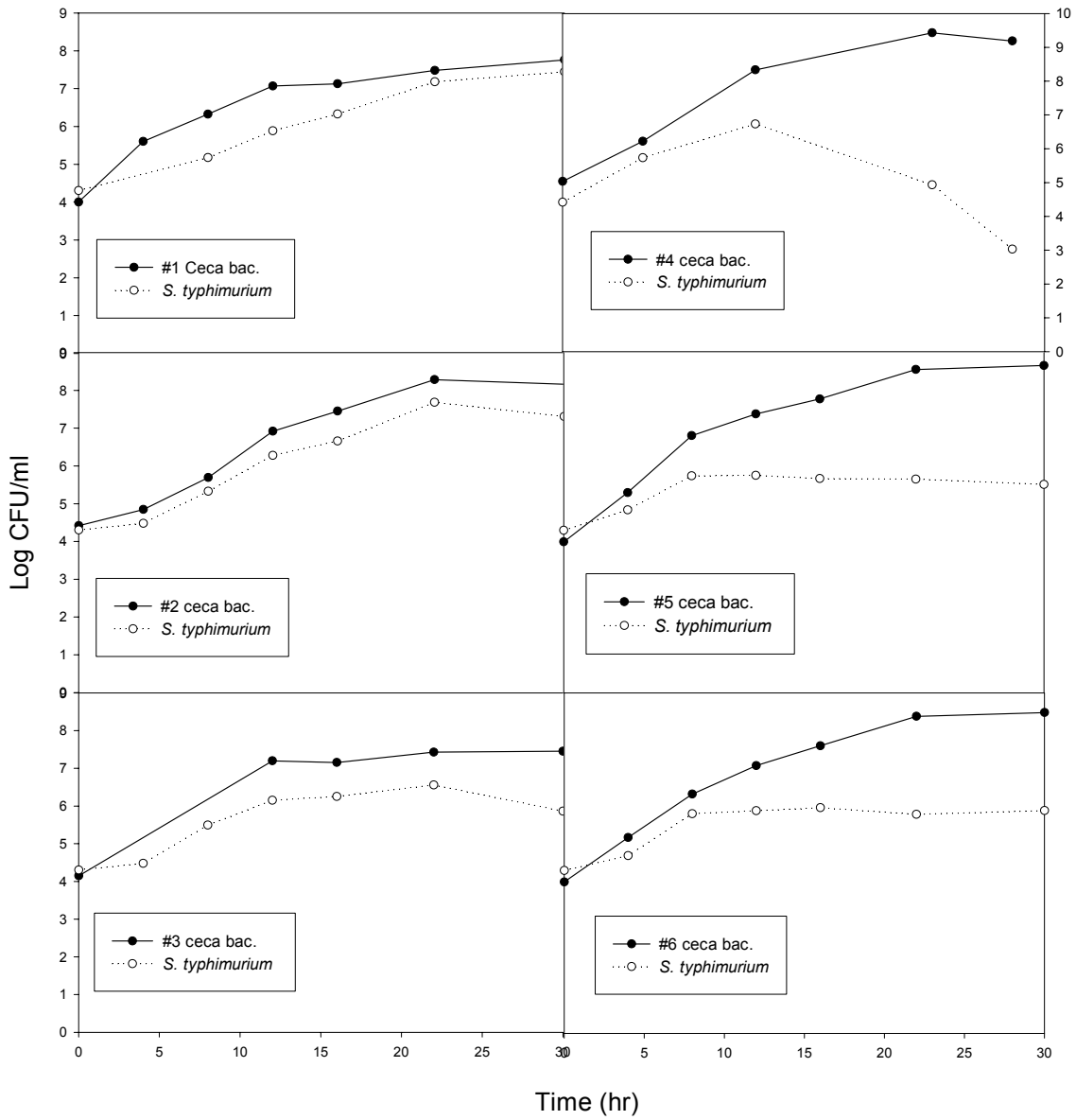

Figure 18. Anaerobic growth of mixed cultures of *S. typhimurium* and ceca bacteria on the glucooligosaccharide preparation at 37°C.

the cecal bacterial isolates, #5 and #6, showed the same use pattern of GOS. Only the DP 3 polymer (panose) was utilized in the first 24 hours (Figure 19).

### 3. Possible Prebiotic Mechanism in Intestines

- $\alpha$ -glucosidase and GOS

The *Leuconostoc* GOS was found to inhibit the activity of  $\alpha$ -glucosidase (maltase) (Figure 20). A double reciprocal plot indicated this was a non-competitive inhibition (Figure 21). In order to determine the role of branching in the inhibition, the  $K_i$  values for panose and isomaltotriose were determined. Only panose, containing  $\alpha$ -1,4 and  $\alpha$ -1,6 linkages, showed an inhibition on  $\alpha$ -glucosidase. Isomaltotriose, a linear glucose polymer linked by two  $\alpha$ -(1 $\rightarrow$ 6) linkages, was not inhibitory (Figure 22, 23).

- Growth test of *B. longum* and *S. typhimurium* with panose and maltodextrins

To determine whether a role for *Leuconostoc* GOS is as a starch metabolism inhibitor, *B. longum* and *S. typhimurium* were grown in different combinations of panose and maltooligosaccharides (from DP 4 to DP 10). As the concentration of panose increased, the growth of *S. typhimurium* slowed but *B. longum* growth increased when panose was supplied in the medium (Figure 24). A comparison of growth rates at log phase clearly showed the growth inhibition of *S. typhimurium* by panose (Figure 25). In the case of *B. longum*, 50% panose + 50% maltooligosaccharides and 75% panose +25% maltooligosaccharides combinations showed better growth than other combinations.

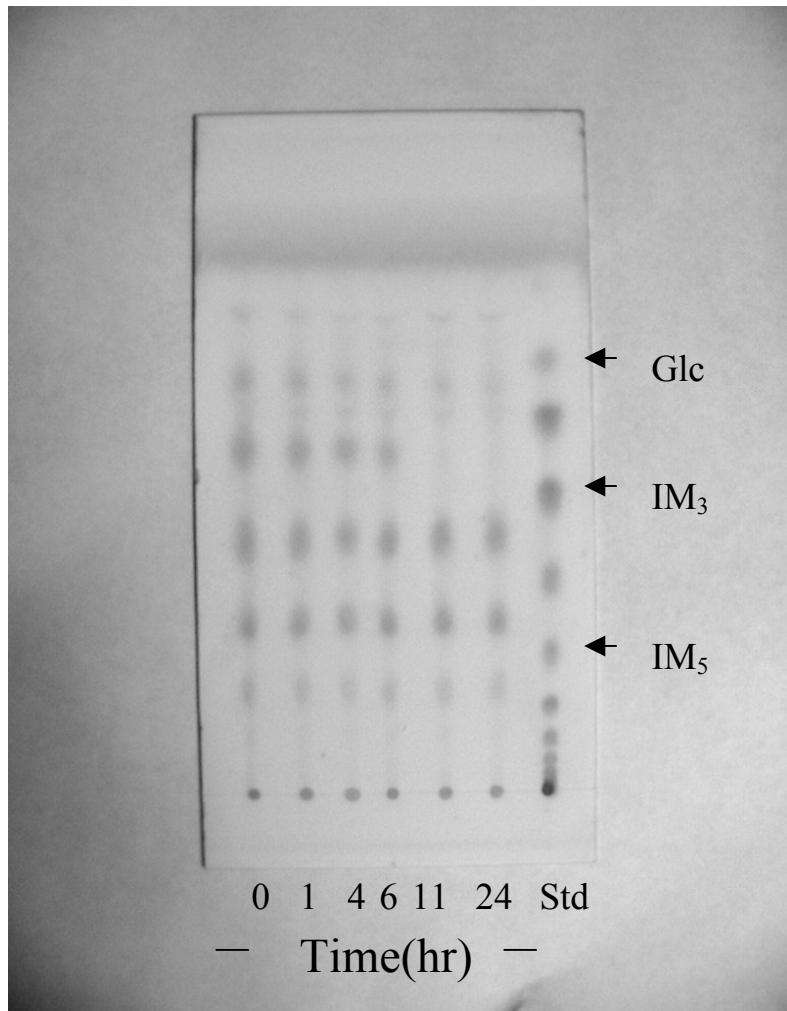

Figure 19. TLC of anaerobic growth of chicken ceca bacterium # 5 on 0.5% glucooligosaccharide preparations. Std, standard; Glc, glucose; IM<sub>3</sub>, isomaltotriose; IM<sub>5</sub>, isomaltopentaose. The solvent system was a mixture of acetonitrile, ethylacetate, propanol, and water (in volume (mL) proportions of 85: 20: 50: 70). After development was complete, the plates were dried and the carbohydrates visualized using a spray of an ethanol solution containing 0.3 % (w/v)  $\alpha$ -naphthol and 5 % (v/v) H<sub>2</sub>SO<sub>4</sub>.

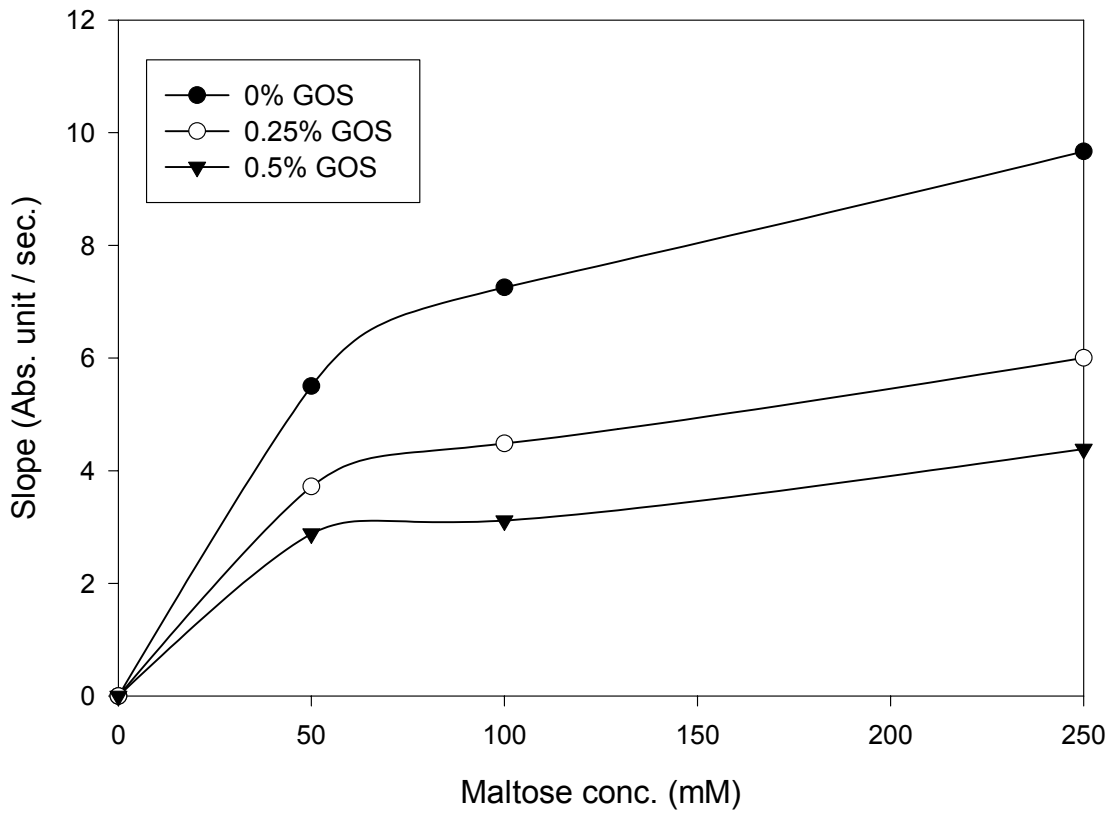

Figure 20.  $\alpha$ -Glucosidase (maltase) activity inhibition with increasing concentrations of *Leuconostoc* glucooligosaccharides. The assay was a linked assay system as described in materials and methods.

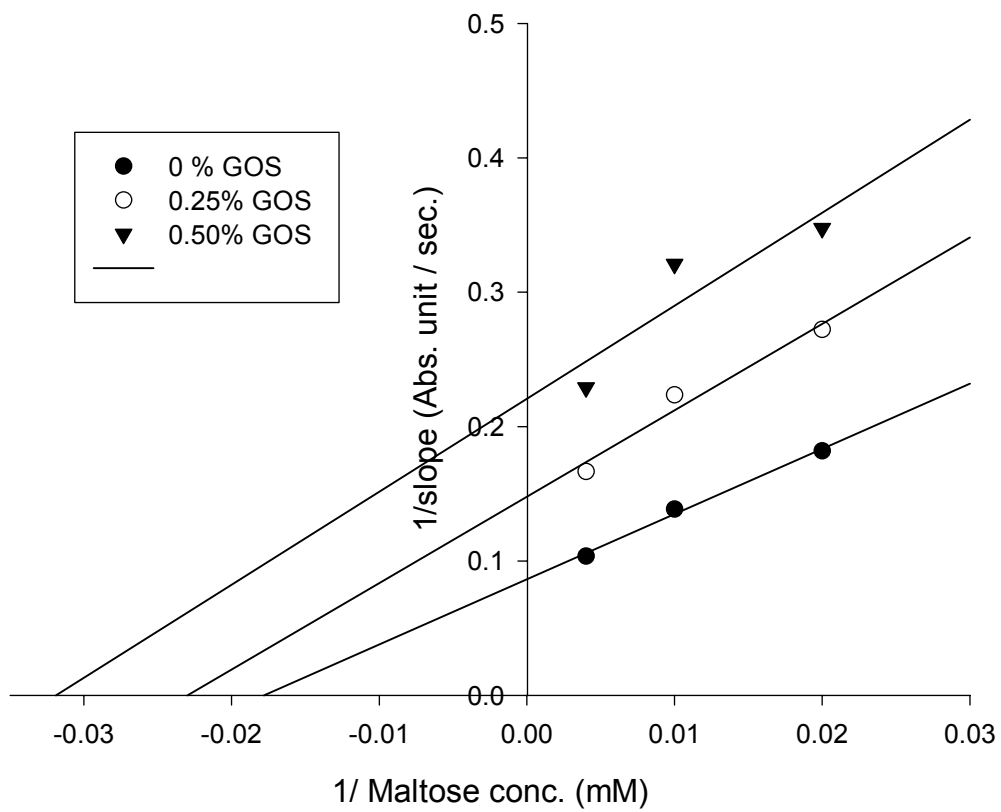

Figure 21. Double reciprocal plot of  $\alpha$ -glucosidase (maltase) activity inhibition as the concentration of the glucooligosaccharides increased.



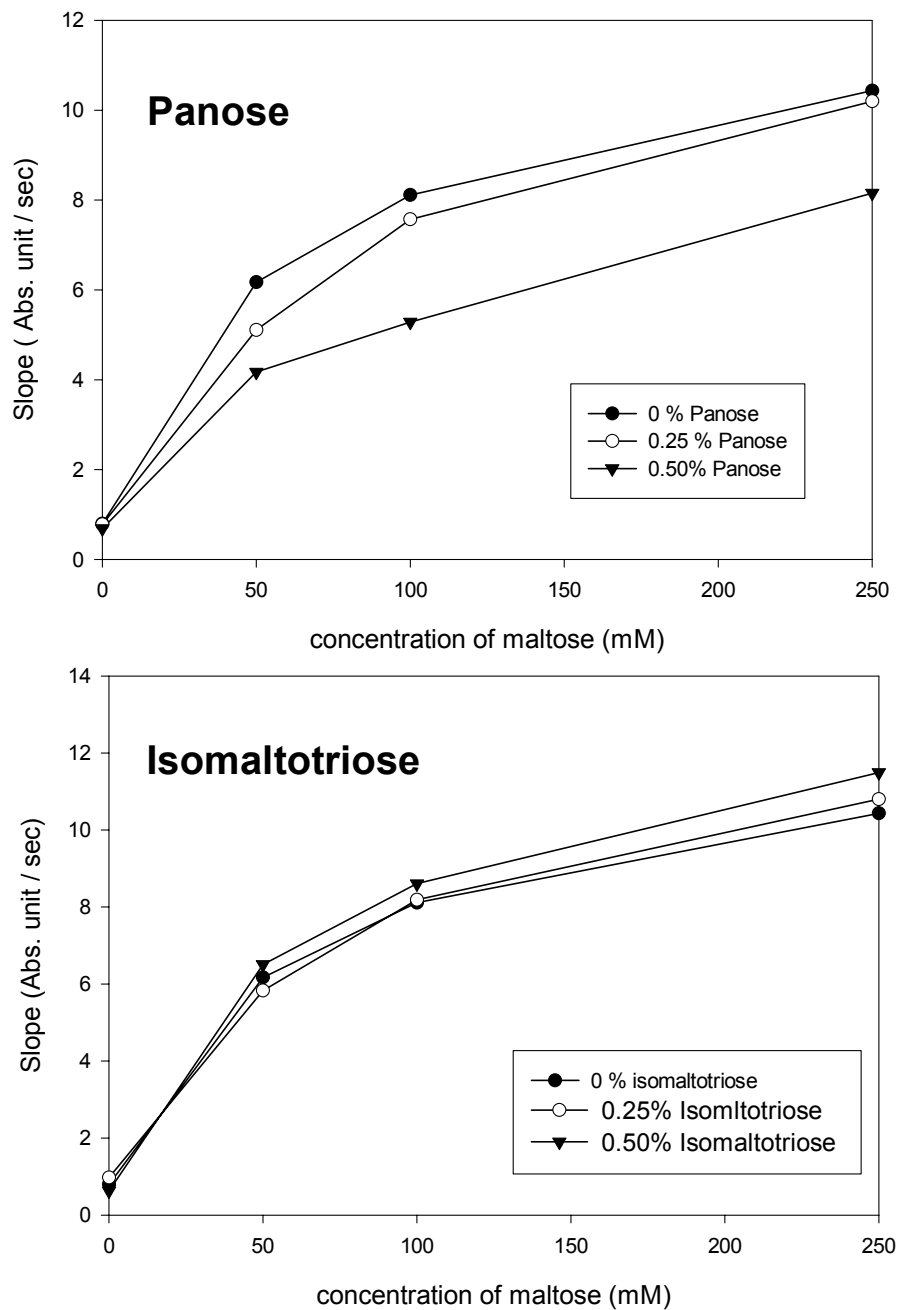

Figure 22.  $\alpha$ -Glucosidase (maltase) activity in the presence of different concentrations of panose (branched;  $\alpha$ -1,4 and  $\alpha$ -1,6) and isomaltotriose (linear; two  $\alpha$ -1,6).

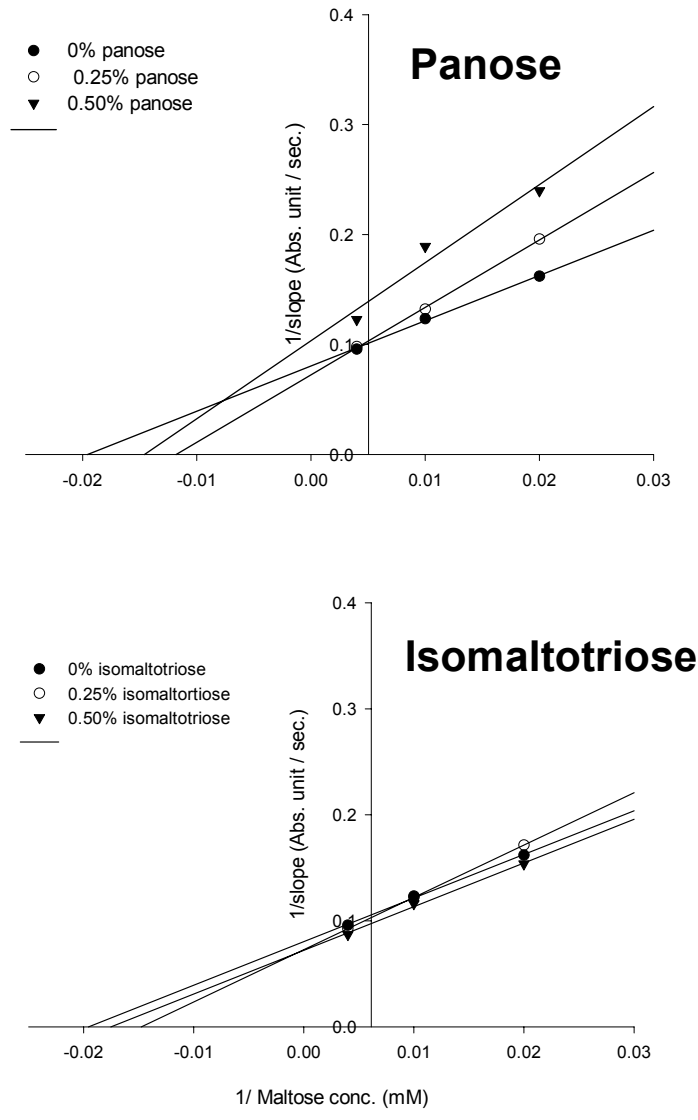

Figure 23. Double reciprocal plot of  $\alpha$ -glucosidase (maltase) activity change as the concentration of panose or isomaltotriose increased.

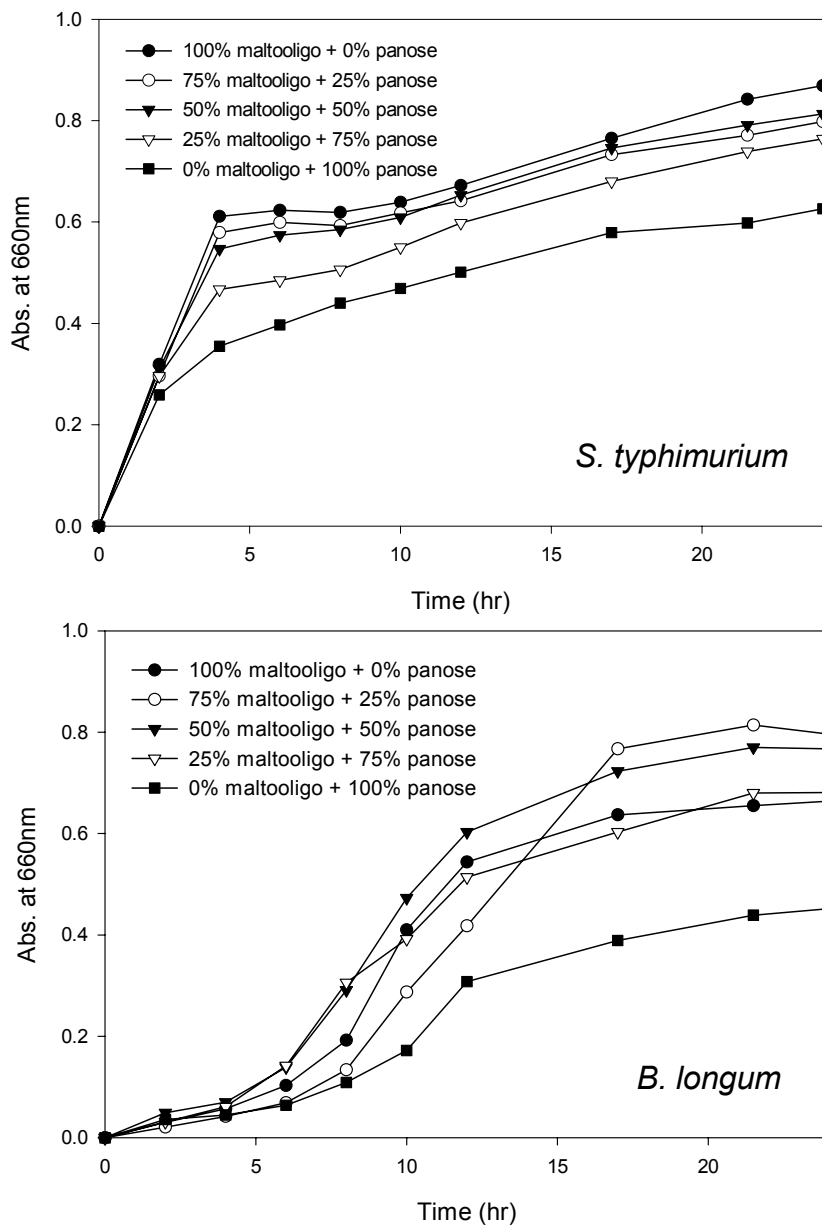

Figure 24. Anaerobic growth of *S. typhimurium* and *B. longum* on different combinations of panose and maltooligosaccharides (d.p. 4 – 10) at 37°C.

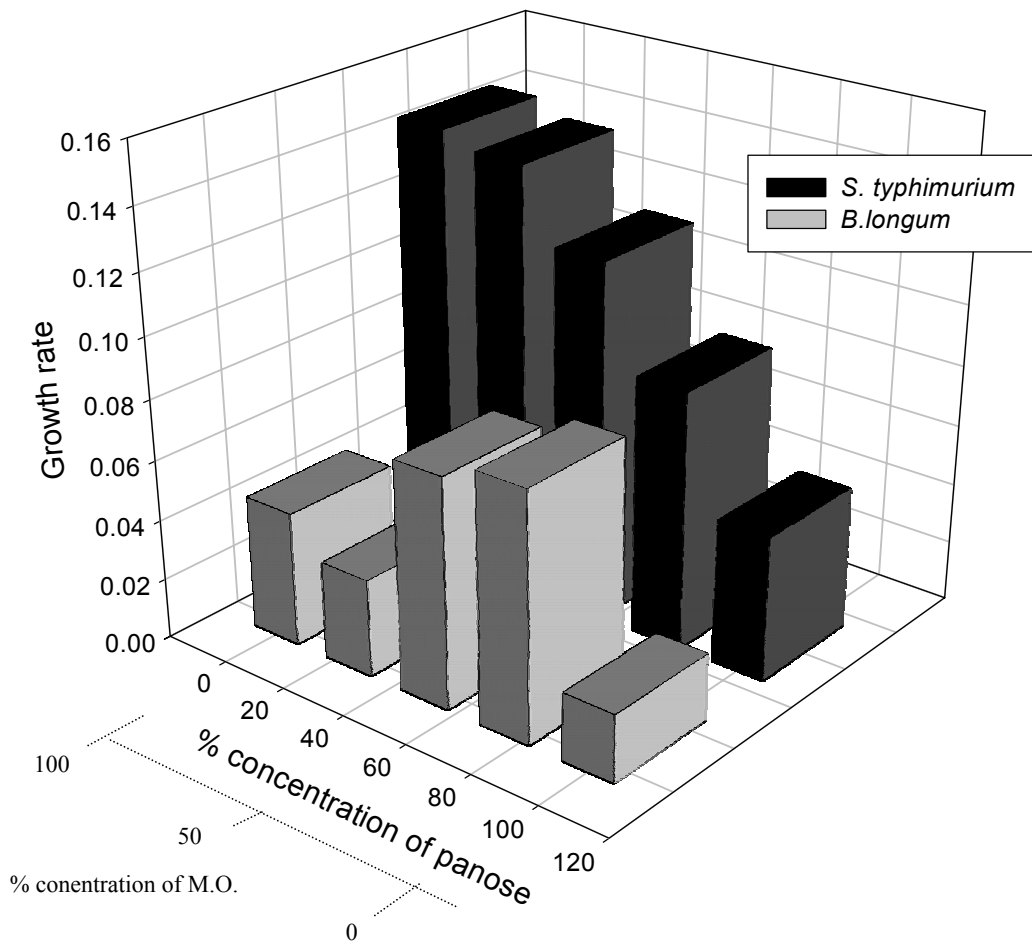

Figure 25. Comparison of growth rates in log phase between *S. typhimurium* and *B. longum* at different concentrations of panose and maltooligosaccharides (M.O.).

## DISCUSSION

Technology for the production of oligosaccharides currently is limited to extraction from plant sources, acid or enzymatic hydrolysis of polysaccharides or synthesis from starch by transglycosylation reactions (Chesson, 1993; Morgan *et al.*, 1992). These processes are costly, limiting use of oligosaccharides to high value products. Conventional fermentation is the simplest means for industrial manufacture of carbohydrate polymers.

Use of a chain shortening acceptor (Yoo, 1997) and a microbial strain that produces primarily branched polymers in a dextran fermentation results in production of branched  $\alpha$ -glucooligosaccharides. High sucrose utilization in the early stages of the fermentation fuels oligosaccharide production and cell growth. Some of the fructose, liberated intracellularly by sucrose phosphorylase, probably is utilized by the cells, accounting for the observed conversion efficiency of 71 %. Fructose that accumulates is a byproduct of sucrose cleavage during synthesis of oligosaccharides. Dols *et al.* (1997) proposed that *L. mesenteroides* possesses an efflux mechanism for fructose such that the cell excretes fructose and then reassimilates the fructose *via* a phosphoenolpyruvate (PEP)-dependent fructose phosphotransferase mechanism (Dominguez and Lindley, 1996). The accumulation of fructose has been observed in other *Leuconostoc* species. (Dols *et al.*, 1997; Dominguez and Lindley, 1996; Lawford *et al.*, 1979; Tsuchiya *et al.*, 1952). As the sucrose is depleted, the accumulating fructose is metabolized and mannitol is produced. Soetaert *et al.* (1995) studied mannitol production by *Leuconostoc* under various batch and continuous culture conditions, with varying media compositions. They concluded that low pH values and temperatures led to increases in conversion efficiency and decreases in conversion rates. They also demonstrated that conversion efficiency strongly depended on the (extracellular) fructose concentration. High fructose

concentrations lead to nearly quantitative conversions, while low fructose concentrations cause a conversion efficiencies to drop below 50%. (Soetaert *et al.*, 1995).

Mannitol was a major end product in the *Leuconostoc* fermentation, but it is necessary to separate mannitol from the oligosaccharides if they are to be used as prebiotics, as mannitol can also be a carbon source for microorganisms. Most of the mannitol (86.4 %) was recovered without further processing by crystallization at 4 °C. To obtain highly purified oligosaccharides (> 98.8 %), a cation exchange column was used. A Ca<sup>2+</sup> resin has high ionic strength and divalent properties, which may account for the increased resolution seen when it was used. On a Ca<sup>2+</sup> resin, oligosaccharides eluted first followed by a mixture of mannitol and organic acids (lactic acid and acetic acid). The smaller mannitol molecule eluted after the oligosaccharides in part because of partial ionization of the mannitol at the 6.5 pH. Divalent cations such as Ca<sup>2+</sup> bind strongly to the organic acids (Miller, 1989; Weaver and Plawecki, 1994). At pH 6.5, which is above the pK value of lactic and acetic acids, they exist in dissociated forms. The stronger organic acid that is lactic (pK of 3.79) eluted later because it interacts more strongly with Ca<sup>2+</sup> than acetic acid, pK value of 4.7.

The oligosaccharides produced were branched polymers between DP 2 and 7 in size. The degree of polymerization (DP) for most prebiotic oligosaccharides falls in the range of DP 2 to 8 (Loo *et al.*, 1999). Those oligosaccharides larger than DP 3 were branched, based on the R<sub>f</sub> values and <sup>13</sup>C N.M.R analysis. Dextrans from *L. mesenteroides* ATCC 13146 show a high degree of branching and exhibit a comblike structure that is resistant to enzyme hydrolysis. The branches are single glucose molecules in length (Cote and Robyt, 1983; Remaud *et al.*, 1992). Oligosaccharides synthesized by the dextransucrase from this bacterium had α-1,6 backbones with α-1,3, and/or α-1,4-branched side chains when maltose was used as an acceptor (Remaud *et al.*,

1992). However, it seems that the glucooligosaccharides produced in this study contain mainly by  $\alpha$ -1,4 and  $\alpha$ -1,6 linkages and maltose is linked to the reducing end of the isomaltosyl residues by judging the  $^{13}\text{C}$  n.m.r. data,.

An earlier study indicated that some pathogenic microorganisms did not grow well on a *L. mesenteroides* ATCC 13146 preparation (Yoo, 1997). Based on this study, the oligosaccharides produced from *L. mesenteroides* (ATCC 13146) were thought to be applicable for enhancing growth of *Bifidobacterium* and *Lactobacilli*. It was expected that ingestion of this preparation could bring the concomitant health effects associated with enhanced *Bifidobacterium* populations.

When *S. typhimurium* or *E. coli* was grown on ATCC 13146 oligosaccharide preparations, there was less than 37% of the equivalent growth on glucose, similar to growth on commercial fructooligosaccharides (less than 35%). *Lactobacillus johnsonii* and *B. longum* showed no differences in growth rate on glucose or the oligosaccharide preparations. When *L. johnsonii* and *S. typhimurium* were grown together on oligosaccharide preparations, the oligomers stimulated the growth of the *Lactobacillus*, but were not readily utilized by the *Salmonella*. TLC showed clearly that the GOS stimulated growth of *Bifidobacterium* but were not utilized readily by *Salmonella* and *E. coli*. It appears that these oligosaccharides are utilized preferentially by some probiotic strains.

The antagonistic role of probiotic strains to pathogens is attributed to competition for available nutrients and/or attachment sites on intestinal epithelial cells and production of antimicrobial compounds such as bacteriocins (Rolfe, 2000; Juven *et al.*, 1991). *Lactobacilli* have been extensively investigated for production of bacteriocins and bacteriocin-like compounds. A limited number of studies have been carried out to demonstrate production of antimicrobials or bacteriocins by the bifidobacterial strains

(Faure *et al.*, 1982; Anand *et al.*, 1985; Meghrous *et al.*, 1990; Bernet *et al.*, 1993; Gibson and Wang, 1994b; Oyarzabal and Conner, 1995; O’Riordan and Fitzgerald, 1998). The homofermentative *Lactobacilli* produce a number of bacteriocins, each with a distinct spectrum of activity (DeKlerk, 1967; DeKlerk and Smit, 1967). For instance, crude lactidin has inhibitory activity against numerous genera including *Proteus* spp., *Salmonella* spp., *E. coli*, and *Staphylococcus* spp. (Vincent *et al.*, 1959). A proteinaceous factor in a culture supernatant fluid of a *B. longum* strain interferes with *Enterobacteriaceae* binding to GA1 receptor sites on the intestinal brush border membrane (Fujiwara *et al.*, 1997; O’Riordan and Fitzgerald, 1998). Other antagonists that can be produced by probiotic bacteria are lactic and acetic acids (Tramer, 1966; Sorrells and Speck, 1970) and hydrogen peroxide (Wheater *et al.*, 1952; Whittenbury, 1964). Organic acids, such as acetic and lactic acid, will inhibit growth of many bacteria, including pathogenic Gram-negative organisms (Burnett and Hanna, 1963; Sorrells and Speck, 1970; Herrick, 1972; Ibrahim and Bezkorovainy, 1993). The undissociated forms are the most bactericidal (Sorrells and Speck, 1970; Adams and Hall, 1988), because the dissociation of the acid molecules following their entry into the cytoplasm reduces the transmembrane proton gradient and neutralizes proton motive force; changing internal pH’s, causing protein denaturation and viability loss (Ray, 1996). The inhibition of *E. coli* by *L. acidophilus* has been shown (Tramer, 1966). Barnes *et al.* (1979) discovered that if the pH was lower than about 5.5, *Salmonella* were unable to multiply.

To test the potential of this GOS as a prebiotic in poultry, six different microbial strains were isolated from chicken ceca. These isolates were identified as lactic acid bacteria by colonial morphology and chemical reaction (Gram positive, catalase negative, and lactic acid formation from glucose, data not shown). When utilization of the *Leuconostoc* glucooligosaccharides by these isolates was compared to utilization of a



commercial fructooligosaccharide (FOS), three of the six isolates showed higher growth after 24 hr on GOS than on FOS. In tests of mixed cultures of these lactic acid bacteria and *Salmonella* on the glucooligosaccharides, five of the six cecal isolates showed higher growth rates and inhibited growth of *Salmonella*. Similar results were seen with *Lactobacillus* and *Bifidobacterium* strains. Two isolates showed identical patterns of consumption of GOS. They only degraded the DP 3 component of the GOS mixture. Similar effects have been seen in studies on the effect of fructooligosaccharides in feed trials with broilers. FOS reduced susceptibility of poultry to *Salmonella* colonization (Bailey *et al.*, 1991), increased *Bifidobacterium* levels, and reduced the level of *Salmonella* present in the caecum. Chamber *et al.* (1997) studied *S. typhimurium* colonization in 3-, 5-, and 6- wk-old broilers fed either a control ration or rations with added fructooligosaccharides (FOS) or lactose derivatives (LD). Both FOS and LD reduced cecal pH and density. In addition, broilers fed refined FOS had a lower rate of infection by *S. typhimurium* than control broilers.

The low pH produced by the chicken cecal bacteria is likely responsible for the observed suppression of *S. typhimurium* growth in mixed cultures. Although other antagonistic substances such as bacteriocins and hydrogen peroxide could be produced that can inhibit *S. typhimurium*, significant levels of lactic acid bacteria must be generated first. These studies do not directly predict *in vivo* effects but indicate that this type of oligomers can be an avian prebiotic.

Although the ability of probiotic bacteria to ferment oligosaccharides may be an especially important characteristic (Collins and Gibson, 1999; Crittenden, 1999; Gibson and Roberfroid, 1995; Macfalane and Cummings, 1999; Roberfroid, 1998; Wang and Gibson, 1993; Kaplan and Hutkins, 2000), there is no clear answer as to why prebiotics stimulate growth of probiotic strains such as *Lactobacilli* and *Bifidobacteria*.

Many genes are required for maltose regulation and the transport and processing of maltodextrins in *E. coli*. For example, the LamB protein is required for binding and transporting maltodextrins across the outer membrane. MalF, MalB, and MalK proteins form a pore in the cytoplasmic or inner membrane that allows the MalE protein in the periplasmic space to pass maltodextrin to the cytoplasm. In the cytoplasm, MalP (maltodextrin phosphorylase; E.C. 2.4.1.1.) and MalQ (amylomaltase; E.C. 2.4.1.25) degrade maltodextrins and maltose to glucose-1-phosphate and glucose, respectively. These compounds act as energy and carbon sources, after conversion to glucose-6-phosphate (Schwartz, 1987).

Because, the glucooligosaccharides produced by *L. mesenteroides* ATCC 13146 are linked by  $\alpha$ -1,4 and  $\alpha$ -1,6 linkages with maltose on the reducing end, it seemed possible that these oligosaccharides might act as inhibitors of those enzymes needed for maltose or maltodextrin utilization.  $\alpha$ -Glucosidase, which cleaves maltose into two glucose molecules, was chosen to test this hypothesis. *L. mesenteroides* ATCC 13146 oligosaccharides were found to be a non-competitive inhibitor of  $\alpha$ -glucosidase (maltase). To verify inhibition of  $\alpha$ -glucosidases by branched oligomers, panose and isomaltotriose were tested for inhibition. Panose contains  $\alpha$ -1,4 and  $\alpha$ -1,6 linkages and is one of the components in the *Leuconostoc* GOS. Panose inhibited  $\alpha$ -glucosidase, whereas isomaltotriose, containing two  $\alpha$ -1,6 linkages in a linear structure, did not. Panose also suppressed growth of *S. typhimurium* but not *B. longum*. *B. longum* showed increased growth when panose and maltodextrins were supplied in the medium together compared with maltodextrin alone. When growth rates at early log phase were compared, growth inhibition of *S. typhimurium* by panose was clearly evident.

Adhesion of *Bifidobacterium* strains to native maize, potato, oat, and barley starch granules has been examined (Crittenden *et al.*, 2001). Interestingly, the  $\alpha$ -1,4-

linked glucose disaccharide, maltose, inhibited adhesion with the degree of inhibition increasing with increasing starch polymer length. No effect was observed with a  $\beta$ -1,4-linked disaccharide, cellobiose, or a  $\alpha$ , $\alpha$ -1,1-linked disaccharide, trehalose. Of 28 strains of lactic acid bacteria and bifidobacteria examined for their ability to ferment fructooligosaccharides (FOS) on MRS agar, 12 of 16 *Lactobacillus* strains and 7 of 8 *Bifidobacterium* strains fermented FOS (Kaplan and Hutkins, 2000). Some strains of bifidobacteria produce an extracellular dextranase, which hydrolyses dextran to a mixture of isomaltotriose, isotetraose, isopentaose and higher isomaltodextrins (Rasic and Kurmann, 1983). An intracellular enzyme,  $\alpha$ -1,6 glucosidase (isomaltodextranase), was found in extracts obtained from a rumen strain of *Bifidobacterium* that was cultured on dextran (Bailey and Robertson, 1962; Rasic and Kurmann, 1983). Human strains of bifidobacteria metabolize raffinose (except *B. bifidum*), lactulose, and N-acetylglucosamine-containing saccharides present in human milk to acetic and lactic acids. Lactulose is also metabolized by *Enterococci* and *Lactobacilli* (Rasic and Kurmann, 1983).

Bearing this in mind, it seems that maltose and maltodextrins could inhibit the adherence of *Bifidobacterium* to starch molecules in the intestine. Therefore, other organisms would compete better in this situation. However, if prebiotic sugars are introduced in the intestine, these sugars may inhibit the flow of starch or maltodextrin utilization. Therefore, the utilization of the carbon source would be biased to the probiotic strains, and then they outcompete other organisms. Healthy probiotic populations can also produce antagonistic compounds such as organic acids and/or bacteriocin. Chambers *et al.* (1997) studied *Salmonella typhimurium* colonization in 3-, 5-, and 6- wk-old broilers fed either a control ration or rations with added fructooligosaccharides (FOS) or lactose derivatives (LD). They observed both FOS and

LD reduced cecal pH and density. Broilers fed refined FOS had lower infections than control broilers. However, the decline of *Salmonella* infections, decreased pH and cecal density of broilers fed either refined FOS or LD disappeared within 1 week after withdrawal of these carbohydrates. A human study of the administration of a milk product containing *Lactobacillus rhamnosus* supported this postulate. In this study, the composition of the fecal microflora of 10 healthy subjects was monitored before (6-month control period), during (6-month test period), and after (3 month post test period) the milk product. During the administration of the product containing *Lactobacillus rhamnosus*, there was a predominance of *L. rhamnosus*, but the population disappeared in most of the subjects after consumption of the product ceased (Tannock *et al.*, 2000).

Oligosaccharides (branched or partially branched) most likely inhibit some of those enzymes required for utilization of starch in other genera, such as *Escherichia* and *Salmonella*. Panose and the *Leuconostoc* oligosaccharides reduced the activity of  $\alpha$ -glucosidase that degrades  $\alpha$ -1,4 linkage in a maltose or maltodextrin. Panose alone did not produce a higher growth rate than maltooligosaccharides and panose together for *B. longum*. It is likely that high concentrations of panose also can inhibit enzymes seen in maltooligosaccharide inhibition. There seems to be a synergistic effect for the probiotic strains on carbon source utilization when maltodextrin and prebiotic sugars are present together.

An examination of the expression levels of maltose operon and enzyme inhibition tests in the presence and absence of prebiotic sugars would be justified to establish if a relationship exists between the maltose operon and prebiotic sugars.

## REFERENCES

- Abo, H., Matsumura, T., Kodama, T., Ohta, H., Fukui, K., Kato, H., and Kagawa, H. 1991. Peptide sequence for sucrose splitting and glucan binding within *Streptococcus sobrinus* glucosyltransferase (water-insoluble glucan synthetase). *J. Bacteriol.* 173:989-996.
- Adams, M.R. and Hall, C.J. 1988. Growth inhibition of food-borne pathogens by lactic and acetic acids and their mixtures. *Int. J. Food Sci. Tech.* 23:287- 292.
- Adawi, D., Kasravi, F.B., Molin, G., and Jeppsson, B. 1997. Effect of *Lactobacillus* supplementation with and without arginine on liver damage and bacterial translocation in an acute liver injury model in the rat. *Hepatology* 25:642- 647.
- Ajisaka, K., Nishida, H., and Fujimoto, H. 1987. The synthesis of oligosaccharides by reversed hydrolysis reaction of  $\beta$ -glucosidase at high substrate concentration and at high temperature. *Biotechnol. Lett.* 9:243- 248.
- Alestig, K., Carlberg, H., Nord, C.E., and Trollfors, B. 1983. Effects of cefoperazone on faecal flora. *J Antimicrob. Chemoth.* 12:163- 167.
- Anand, S.K., Srinivasan, R.A., and Rao, L.K. 1985. Antibacterial activity associated with *Bifidobacterium bifidum*-II. *Cultured Dairy Products Journal* 2:21- 23.
- Anonymous. 1999. Fructooligosaccharides. *Crit. Rev. Food Sci.* 39: 267- 274.
- Bailey, J.S, Blackenship, L.C. and Cox, N.A. 1991. Effect of fructooligosaccharide on *Salmonella* colonization of the chicken intestine. *Poultry Sci.* 70: 2433- 2438.
- Bailey, R.W. and Robertson, A.M. 1962. Carbohydrases of a rumen strain of *Lactobacillus bifidus*. The intracellular  $\alpha$ -1,6-glucosidase (isomaltodextranase). *Biochem. J.* 82: 272-277.
- Ballongue, J. 1998. Bifidobacteria and probiotic action. *In: S. Salminen and A. von Wright (eds.), Lactic acid bacteria: microbiology and functional aspects.* p. 519- 597. Marcel Dekker Inc., New York, N.Y.
- Banas, J.A., Simon, D., Williams, L.K., Ferretti, J.J., Russell, R.R.B. 1994. Analysis of a primer-independent GTF-I from *Streptococcus salivarius*. *FEMS Microbiol. Lett.* 123:349- 354.
- Barnes, E.M., Impey, C.S., and Stevens, B.J.H. 1979. Factors affecting the incidence and anti-*Salmonella* activity of the anaerobic cecal flora of the young chick. *J. Hyg.- Camb.* 82:263- 283.
- Bart, H.J., Messenböck, R.C., Byers, C.H., Prior, A., and Wolfgang, J. 1996. Continuous chromatographic separation of fructose, mannitol and sorbitol. *Chem. Eng. Process* 35:459-471.

- Bernet, M.F., Brassart, D., Neeser, J.-R., and Servin, A.L. 1993. Adhesion of human bifidobacterial strains to cultured human intestinal epithelial cells and inhibition of enteropathogen-cell interactions. *Appl. Environ. Microbiol.* 59:4121- 4128.
- Black, F., Einarsson, K., Lidbeck, A., Orrhage, K., and Nord, C.E. 1991. Effect of lactic acid producing bacteria on the human intestinal microflora during ampicillin treatment. *Scand. J. Infect. Dis.* 23:247- 254.
- Burnett, G.S. and Hanna, J. 1963. Effect of dietary calcium lactate and lactic acid on faecal *Escherichia coli* counts in pigs. *Nature* 197:815.
- Campbell, J.M., Fahey, G.C. Jr., and Wolf, B.W. 1997. Selected indigestible oligosaccharides affect large bowel mass, cecal and fecal short chain fatty acids, pH and microflora in rats. *J. Nutr.* 127:130- 136.
- Canzi, E., Brighenti, F., Casighari, M.C., et al., 1995. Prolonged consumption of inulin in ready-to-eat breakfast cereals: effects on intestinal ecosystem, bowel habits and lipid metabolism. EU-Cost 92, Workshop on dietary fiber and fermentation in the colon. Helsinki:Luxembourg office for official publication of the European Communities, p. 280-284.
- Castagliuolo, I., LaMont, J.T., Nikulasson, S.T. and Pothoulakis, C. 1996. *Saccharomyces boulardii* protease inhibits *Clostridium difficile* toxin A effects in the rat ileum. *Infect. Immun.* 64:5225- 5232.
- Castagliuolo, I., Riegler, M.F., Valenick, L., LaMont, J.T. and Pothoulakis, C. 1999. *Saccharomyces boulardii* protease inhibits the effects of *Clostridium difficile* toxin A and B in human colonic mucosa. *Infect. Immun.* 67:302- 307.
- Chambers, J.R., Spencer, J.L., and Modler, H.W. 1997. The influence of complex carbohydrates on *Salmonella typhimurium* colonization, pH, and density of broiler ceca. *Poultry Sci.* 76: 445-451.
- Chesson, A. 1993. Probiotics and other intestinal mediators. *In: D.J.A. Cole, J. Wiseman, and M.A. Varley (eds.) Principles of Pig Science* p. 197- 214. Nottingham University Press, Loughborough, UK.
- Chou, C-C. and How, J-W. 2000. Growth of bifidobacteria in soymilk and their survival in the fermented soymilk drink during storage. *Int. J. Food Microbiol.* 56:113-121.
- Chung, H.S., Kim, Y.B., Chun, S.L., and Ji, G.E. 1999. Screening and selection of acid and bile resistant bifidobacteria. *Int. J. Food Microbiol.* 47:25-32.
- Collins, M.D. and Gibson, G.R. 1999. Probiotics, prebiotics, and synbiotics: approaches for modulating the microbial ecology of the gut. *Am. J. Clin. Nutr.* 69(suppl.):1052S-1057.
- Colombel, J.F., Cortot, A., Neut, C., and Romond, C. 1987. Yoghurt with *Bifidobacterium longum* reduces erythromycin-induced gastrointestinal effects. *Lancet* 2:43.

- Conway, P.L., Gorbach, S.L., and Goldin, B.R. 1987. Survival of lactic acid bacteria in the human stomach and adhesion to intestinal cells. *J. Dairy Sci.* 70:1- 12.
- Corthier G. 1997. Antibiotic-associated diarrhoea and pseudomembranous colitis. *In: R. Fuller (ed.) Probiotics 2: applications and practical aspects.* p.10- 39. Chapman and Hall, London, UK.
- Cote, G.L. and Robyt, J.F. 1983. The formation of  $\alpha$ -D-(1,3) branch linkages by an exocellular glucansucrase from *L. mesenteroides* NRRL B-742. *Carbohydr. Res.* 119:141-156.
- Cote, G.L. and Robyt, J.F. 1984. The formation of  $\alpha$ -D-(1,3) branch linkages by  $\alpha$ -D-glucansucrase from *S. mutans* 6715 producing a soluble D-glucan. *Carbohydr. Res.* 127:95- 107.
- Coudray, C, Bellanger, J., Castiglia-Delavaud, C., Remesy, C., Vermorel, M., and Rayssiguier, Y. 1997. Effect of soluble or partly soluble dietary fibres supplementation on absorption and balance of calcium, magnesium, iron, and zinc in healthy young men. *Eur. J. Clin. Nutr.* 51:375- 380.
- Crittenden, R, A Laitila, P Forssell, J Matto, M Saarela, T Mattila-Sandholm, and P Myllarinen. 2001. Adhesion of bifidobacteria to granular starch and its implications in probiotic technologies. *Appl Environ Microbiol* 67: 3469- 3475.
- Crittenden, R.G. 1999. Prebiotics. *In: G.W. Tannock (ed), Probiotics: a critical review.* p. 141- 156. Horizon Scientific Press, Wymondham, Norfolk, U.K.
- Davidson, M.H., Maki, K.C., Synecki, C., et al. 1998. Evaluation of the influence of dietary inulin on serum lipids in adults with hypercholesterolemia. *Nutrition* 18:503- 517.
- Debord, B., Lefebvre, C., Guyot-Hermann, A.M., Hubert, J., Bouche, R., and Guyot, J.C. 1987. Study of different crystalline forms of mannitol-comparative behavior under compression. *Drug Dev. Ind. Pharmacy* 30:1533.
- Deklerk, H.C. 1967. Bacteriocinogeny in *Lactobacillus fermenti*. *Nature* 192:340- 341.
- Deklerk, H.C. and Smit, J.A. 1967. Properties of a *Lactobacillus fermenti* bacteriocin. *J. Gen. Microbiol.* 48:309- 316.
- Delzenne et al. Delzenne, N., Aertssens, J., Verplaetse, H., Roccaro, M., and Roberfroid, M. 1995. Effect of fermentable fructo-oligosaccharides on mineral, nitrogen and energy digestive balance in the rat. *Life Sci.* 57:1579- 1587.
- Delzenne, N.M., and Kok, N.N. 1999. Biochemical basis of oligofructose-induced hypolipidemia in animal models. *J. Nutr.* 129(suppl):S1467- S1470.
- DeMoss, R.D., Bard, R.C., and Gunsalus, I.C. 1951. The mechanism of the heterolactic fermentation: a new route of ethanol formation. *J. Bacteriol.* 62: 499- 511.

- Ditson, S.L. and Mayer, R.M. 1984. Dextranucrase: the direction of chain growth during autopolymerisation. *Carbohydr. Res.* 126:170-175.
- Djouzi, Z. and Andrieux, C. 1997. Compared effects of three oligosaccharides on metabolism of intestinal microflora in rats inoculated with a human faecal flora. *Br. J. Nutr.* 78:313- 324.
- Djouzi, Z., Andrieux, C., Pelenc, V., Somarriba, F., Popot, F., Paul, F., Monsan, P., and Szylit, O. 1995. Degradation and fermentation of  $\alpha$ -gluco-oligosaccharides by bacterial strains from human colon: *in vitro* and *in vivo* studies in gnotobiotic rats. *J. Appl. Bact.* 79:117-127.
- Dols, M., Remaud-Simeon, M., Willemot, R.M., Vignon, M., and Mosan, P. 1998. Characterization of the different dextranucrase activities excreted in glucose, fructose or sucrose medium by *Leuconostoc mesenteroides* NRRL B-1299. *Appl. Environ. Microbiol.* 64: 1298-1302.
- Dols, M., Chraibi, W., Remaud-Simeon, M., Lindley, N.D., and Mosan, P.F. 1997. Growth and energetics of *Leuconostoc mesenteroides* NRRL B-1299 during metabolism of various sugars and their consequences for dextranucrase production. *Appl. Environ. Microbiol.* 63: 2159-2165.
- Dominguez, H., and N.D. Lindley. 1996. Complete sucrose metabolism requires fructose phosphotransferase activity in *Corynebacterium glutamicum* to ensure phosphorylation of liberated fructose. *Appl. Environ. Microbiol.* 62:3878- 3880.
- Duffy, L.C., Zielesny, M.A., Riepenhoff-Talty, M., Dryja, D., Sayahtheri-Altaie, S., Griffiths, E., Ruffin, D., Barrett, H., Rossman, J., and Ogra, P.L. 1994. Effectiveness of *Bifidobacterium bifidum* in mediating the clinical course of murine rotavirus diarrhea. *Pediatr. Res.* 35:690- 695.
- Ebert, K.H. and Brosche, M. 1967. Origin of branches in native dextrans. *Biopolymers* 5:423- 430.
- Erickson, K. and Hubbard, N. 2000. Probiotic immunomodulation in health and disease. *J. Nutr.* 130(suppl): 403S-409S.
- Famularo, G., Moretti, S., Marcellini, S., and DeSimone, C. 1997. *In: Fuller R. (ed) Probiotics 2: application and practical aspects.* p.133- 161. Chapman and Hall, London, U.K.
- Faure, J.C., Schellenberg, A., Bexter, A. and Wurzner, H.P. 1982. Barrier effect of *Bifidobacterium longum* on *Escherichia coli* in germ-free rat. *J. Nutr. Vitamin Res.* 52: 225.
- Ferain, T., Schanck, A.N., and Delcour, J. 1996.  $^{13}\text{C}$  nuclear magnetic resonance analysis of glucose and citrate end products in an *ldhL-ldhD* double-knockout strain of *Lactobacillus plantanum*. *J. Bacteriol.* 178:7311-7315.



- Ferretti, J.J., Gilpin, M.L., and Russell, R.R.B. 1987. Nucleotide-sequence of a glucosyltransferase gene from *Streptococcus sobrinus* mfe28. *J. Bacteriol.* 169:4271-4278.
- Fishbein, L., Kaplan, M., and Cough, M. 1988. Fructooligosaccharides: a review. *Vet. Hum. Toxicol.* 30:104- 107.
- Flickinger, E.A., Wolf, B.W., Garleb, K.A., Chow, J., Leyer, G.J., Johns, P.W., and Fahey, G.C. Jr. 2000. Glucose-based oligosaccharides exhibit different *in vitro* fermentation patterns and affect *in vivo* apparent nutrient digestibility and microbial populations in dogs. *J. Nutr.* 130: 1267 –1273.
- Forsell, P., Myllärinen, P., Heinämäki, J., Palviainen, P., Yliruusi, J, and Poutanen, K. 1999 October. Coated starch capsules and a process for producing them. World patent WO9952512A1.
- Freter, R. 1992. Factors affecting the microecology of the gut. *In: Fuller R. (ed.) Probiotics: the scientific basis.* p. 111- 144. Chapman and Hall, London, U.K.
- Fujii, S. and Komoto, M. 1991. Novel carbohydrate sweeteners in Japan. *Zuckerindustrie* 116:197- 200.
- Fujiwara, S., Hashiba, H., Hirota, T., and Forstner, J.F. 1997. Proteinaceous factor(s) in culture supernatant fluids of bifidobacteria which prevent the binding of enterotoxigenic *Escherichia coli* to gangliotetraosylceramide. *Appl. Environ. Microbiol.* 63:506- 512.
- Fukata, T., Sasai, K., Miyamoto, T., and Baba, E. 1999. Inhibitory effects of competitive exclusion and fructooligosaccharide, singly and in combination, on *Salmonella* colonization of chicks. *J. Food. Prot.* 62: 229-233.
- Fukushima, Y and Nakano, M. 1996. Effects of a mixture of organisms *Lactobacillus acidophilus* or *Streptococcus faecalis* on cholesterol metabolism in rats fed on a fat- and cholesterol-enriched diet. *Br. J. Nutr.* 76:857- 867.
- Fukushima, Y., Kawata, Y., Hara, H., Terada, A. and Mitsuoka, T. 1998. Effect of a probiotic formula on intestinal immunoglobulin A production in healthy children. *Int. J. Food Microbiol.* 42:39- 44.
- Fuller, R. and Gibson, G.R. 1997. Modification of the intestinal microflora using probiotics and prebiotics. *Scand. J. Gastroenterol Suppl.* 222:28- 31.
- Gray, G.M. 1970. Carbohydrate digestion and absorption. *Gastroenterology* 58:96- 107.
- Gray, G.M. 1992. Starch digestion and absorption in nonruminants. *J. Nutr.* 122:172-177.
- Gibson, G.R. and Wang, X. 1994a. Bifidogenic properties of different types of fructooligosaccharides. *Food Microbiol.* 11:491- 498.
- Gibson, G.R. and Wang, X. 1994b. Regulatory effects of bifidobacteria on the growth of other colonic bacteria. *J. Appl. Bacteriol.* 77:412- 420.

- Gibson, G.R., and Roberfroid, M.B. 1995. Dietary modulation of the human colonic microbiota: introducing the concept of prebiotics. *J. Nutr.* 125:1401- 1412.
- Gibson, G.R., Beatty, E.R., Wang, X., and Cummings, J.H. 1995. Selective stimulation of bifidobacteria in the human colon by oligofructose and inulin. *Gastroenterology* 108:975- 982.
- Giffard, P.M., Allen, D.M., Milward, C.P., Simpson, C.L., and Jacques, N.A. 1993. Molecular characterization of a cluster of at least 2 glucosyltransferase genes in *Streptococcus salivarius* ATCC 25975. *J. Gen. Microbiol.* 139:1511- 1522.
- Giffard, P.M., Simpson, C.L., Milward, C.P., and Jacques, N.A. 1991. Molecular characterization of a cluster of at least 2 glucosyltransferase genes in *Streptococcus salivarius* ATCC 25975. *J. Gen. Microbiol.* 137:2577- 2593.
- Gill, H.S., Rutherford, K.J., Prasad, J., Gopal, P.K. 2000. Enhancement of natural and acquired immunity by *Lactobacillus rhamnosus* (HN001), *Lactobacillus acidophilus* (HN017) and *Bifidobacterium lactis* (HN019). *Br. J. Nutr.* 83:167- 176.
- Gmeiner, M., Kneifel, W., Kulbe, K.D., Woutlers, R., De Boever, P., Nollet, L., and Verstraete, W. 2000. Influence of a symbiotic mixture consisting of *Lactobacillus acidophilus* 72-4 and a fructooligosaccharide preparation on the microbial ecology sustained in a simulation of the human intestinal microbial ecosystem (SHIME reactor). *Appl. Microbiol. Biot.* 53:219- 223.
- Goldin, B.R. 1998. Health benefits of probiotics. *Br. J. Nutr.* 80(suppl):S203- S207.
- Goldin, B.R., Gorbach, S.L., Saxelin, M., Barakat, S., Gualtieri, L. and Salminen, S. 1992. Survival of *Lactobacillus* species (strain GG) in human gastrointestinal tract. *Dig. Dis. Sci.* 37:121- 128.
- Gore, E.B., Miller, C.H., and Spandan, D.F. 1988. Degradation of starch and hydrolytic products by oral bacteria. *J. Dent. Res.* 67:75-81.
- Grobben, G.J., Peters, S.W.P.G., Wisselink, H.W., Weusthuis, R.A., Hoefnagel, M.H.N., Hugenholtz, J., and Eggink, G. 2001. Spontaneous formation of a mannitol-producing variant of *Leuconostoc pseudomensenteroides* grown in the presence of fructose. *Appl. Environ. Microbiol.* 67:2867- 2870.
- Guarner, F. and Schaafsma, G.J. 1998. Probiotics. *Int. J. Food Microbiol.* 39:237- 238.
- Hartemink, R. and Rombouts, F.M. 1999. Comparison of media for the detection of bifidobacteria, lactobacilli and total anaerobes from faecal samples. *J. Microbiol. Meth.* 36:181- 192.
- Hasler, C.M. 1996. Functional Foods: the western perspective. *Nutr. Rev.* 54:6- 10.
- Hasler, C.M. 1998. Functional foods: their role in disease prevention and health promotion. *Food Technol.* 52(11):63- 70.

- Hediger, M.A., Coady, M.J., Ikeda, T.S., and Wright, E.M. 1987. Expression cloning and cDNA sequencing of the Na<sup>+</sup>/glucose co-transporter. *Nature* 330:379- 381.
- Heinz, F. and Vogel, M. 1991. Process for preparing a low glucose, fructose and saccharose inulooligosaccharide product. European Patent 0440074 A1.
- Henrissat, B. and Bairoch, A. 1996. Updating the sequence-based classification of glycosyl hydrolases. *Biochem. J.* 316:695- 696.
- Herrick, J.B. 1972. Therapeutic nutrition using *Lactobacillus* species. *Vet. Med. Sm. Anim. Clin.* 67: 1249.
- Heuvel, E.G. van den, Muys, T., Dokkum, W. van, and Schaafsma, G. 1999. Oligofructose stimulates calcium absorption in adolescents. *Am. J. Clin. Nutr.* 69:544-548.
- Hidaka, H. and Hirayama, M. 1991. Useful characteristics and commercial applications of fructooligosaccharides. *Biochem. Soc. Trans.* 19:561- 565.
- Hidaka, H., Hirayama, M., and Sumi, N. 1988. A fructooligosaccharide-producing enzyme from *Aspergillus niger* ATCC 20611. *Agric. Biol. Chem.* 52:1181- 1187.
- Hileman, B. 2001. Furor over animal antibiotic use. *C&EN.* Feb. 19 p. 47- 52.
- Hofacre, C.L., Froyman, R., Gautrias, B., George, B., Goodwin, M.A., and Brown, J. 1998. Use of aviguard and other intestinal bioproducts in experimental *Clostridium perfringens*-associated necrotizing enteritis in broiler chickens. *Avian Dis.* 42:579- 584.
- Hosono, A., Kitazawa, H., and Yamaguchi, T. 1997. Antimutagenicity and antitumor activities of lactic acid bacteria. *In: Fuller R. (ed.) Probiotics 2: applications and practical aspects.* p. 89- 132. Chapman and Hall, London, U.K..
- Howard, M.D., Gordon, D.T., Pace, L.W., Garleb, K.A., Kerley, M.S. 1995. Effects of dietary supplementation with fructooligosaccharides on colonic microbiota populations and epithelial cell proliferation in neonatal pigs. *J. Pediatr. Gastroenterol. Nutr.* 21:297-303.
- Hucker, G.J. and Pederson, C.S. 1930. Studies on the *Coccaceae*. XVI. Genus *Leuconostoc*. N.Y. Agr. Expt. Sta., Tech. Bull. 167:3- 80.
- Hudault, S., Lievin, V., Bernet-Camard M.F., and Servin, A.L. 1997. Antagonistic activity exerted *in vitro* and *in vivo* by *Lactobacillus casei* (strain GG) against *Salmonella typhimurium* C5 infection. *Appl. Environ. Microbiol.* 63:513- 518.
- Ibrahim, S.A. and Bezkorovainy, A. 1993. Inhibition of *Escherichia coli* by bifidobacteria. *J. Food Protect.* 56:713- 715.

Imaizumi, K., Nakatsu, Y., Sato, M., Sedarnawati, Y., and Sugano, M. 1991. Effects of xylooligosaccharides on blood glucose, serum and liver lipids and caecum short-chain fatty acids in diabetic rats. *Agric. Biol. Chem.* 55:199- 205.

IOM/NAS. 1994. "Opportunities in the Nutrition and Food Sciences". *In*: P.R. Thomas and R. Earl (eds) p. 109. Institute of Medicine/National Academy of Sciences, National Academy Press, Washington, D.C.

Isolauri, E., Juntunen, M., Rautanen, T., Sillanaukee, P., and Koivula, T. 1991. A human *Lactobacillus* strain (*Lactobacillus casei* strain GG) promotes recovery from acute diarrhea in children. *Pediatrics* 88:90- 97.

Ito, S.H., T. Kobayashi, Y. Ohta, and Y. Akiyama. 1983. Inhibition of glucose catabolism by aeration in *Leuconostoc mesenteroides*. *J. Ferment. Technol.* 61: 353- 358.

Jackson T.G., Tayler, G.R.J., Clohessy, A.M., et al. 1999. The effects of the daily intake of inulin on fasting lipid, insulin and glucose concentrations in middle-aged men and women. *Br. J. Nutr.* 89:23- 30.

Jeanes, A., Haynes, W.C., Williams, C.A., Rankin, J.C., Melvin, E.H., Austin, M.J., Cluskey, J.E., Fisher, B.E., Tsushiya, H.M., and Rist, C.E. 1954. Characterization and classification of dextrans from ninety-six strains of bacteria. *J. Am. Chem. Soc.* 76:5041-5052.

Johnson, M.K., and C.S. McCleskey. 1957. Studies on the aerobic carbohydrate metabolism of *Leuconostoc mesenteroides*. *J. Bacteriol.* 74:22 –25.

Juven, B.J., Meinersmann, R.J., and Stern, N.J. 1991. Antagonistic effects of lactobacilli and pediococci to control intestinal colonization by human enteropathogens in live poultry. *J. Appl. Bacteriol.* 70: 95- 103.

Kagan, B.O., Latker, S.M., and E.M. Zfasman. 1942. Phosphorolysis of saccharose by cultures of *Leuconostoc mesenteroides*. *Biokhimiya* 7: 93- 108.

Kaila, M., Isolauri, E., Soppi, E., Virtanen, E., Laine, S., and Arvilommi, H. 1992. Enhancement of the circulating antibody secreting cell response in human diarrhea by a human *Lactobacillus* strain. *Pediatr. Res.* 32:141- 144.

Kaplan, H. and Hutkins, R.W. 2000. Fermentation of fructooligosaccharides by lactic acid bacteria and bifidobacteria. *Appl. Environ. Microbiol.* 66:2682-2684.

Kato, I., Tanaka, K., Yokokura, T. 1999. Lactic acid bacterium potently induces the production of interleukin-12 and interferon-gamma by mouse splenocytes. *Int. J. Immunopharmacol* 21:121- 131.

Kato, C., Nakano, Y., Lis, M., and Kuramitsu, H.K. 1992. Molecular genetic-analysis of the catalytic site of *Streptococcus mutans* glucosyltransferases. *Biochem. Biophys. Res. Commun.* 189:1184- 1188.

- Kim, D and Robyt, J.F. 1995. Production, selection, and characteristics of mutants of *Leuconostoc mesenteroides* B-742 constitutive for dextransucrases. *Enzyme Microb. Tech.* 17: 689 –695.
- Kim, D. and Robyt, J.F. 1996. Dextransucrase constitutive mutants of *Leuconostoc mesenteroides* NRRL B-1299. *Enzyme Microbiol. Technol.* 17:1050- 1056.
- Kim, H.S. and Gillard, S.E. 1983. *Lactobacillus acidophilus* as a dietary adjunct for milk to aid lactose digestion in humans. *J. Dairy Sci* 66:959- 966.
- Kleeman, E.G. and Klaenhammer, T.R. 1982. Adherence of *Lactobacillus* species to human fetal intestinal cells. *J. Dairy Sci.* 65:2063- 2069.
- Kleessen, B., Sykura, B., Zunft, H.J. and Blaut, M. 1997. Effects of inulin and lactose on fecal microflora, microbial activity, and bowel habit in elderly constipated persons. *Am. J. Clin. Nutr.* 65:1397- 1402.
- Kobayashi, M., and K. Matsuda. 1986. Electrophoretic analysis of the multiple forms of dextransucrase from *Leuconostoc mesenteroides*. *J. Biochem.* 100: 615- 621.
- Kobayashi, S., Nakashima, K. and Arahira, M. 1989. Production and some properties of branched cyclomalto-oligosaccharides. *Carbohydr. Res.*, 192:223- 231.
- Kociubinski, G., Perez, P., and Antoni, G.D. 1999. Screening of bile resistance and bile precipitation in lactic acid bacteria and bifidobacteria. *J. Food Protect.* 62:905- 912.
- Koepsell, H.J., Tsuchiya, H.M., Hellman, N.N., Kazenko, A., Hoffman, C.A., Sharpe, E.S., and Jackson, R.W. 1952. Enzymatic synthesis of dextran. acceptor specificity and chain initiation. *J. Biol. Chem.* 200: 793- 801.
- Kohmoto, T., Fukui, F., Takaku, H., Machida, Y., Arai, M., and Mitsuoka, T. 1988. Effect of isomalto-oligosaccharides on human fecal flora. *Bifidobacteria Microflora* 7:61 –69.
- Kok, N.N., Taper, H.S., and Delzenne N.M. 1998. Oligofructose modulates lipid metabolism alterations induced by a fat rich diet in rats. *J. Appl. Toxicol.* 18:47- 53.
- Kormelink, F.J.M., Gruppen, H., Wood, T.M., and Beldman, G. 1992. Mode of action of the xylan-degrading enzymes from *Aspergillus awamori*. *In: J. Visser, G. Beldman, M.A. Kusters-Van Someren and A.G.J. Voragen (eds.) Xylans and Xylanases.* p. 141- 147. Elsevier, London, U.K.
- Korshunov, V.M., Sinitsyna, N.A., Ginodman, G.A., and Pinegin, B.V. 1985. Correction of intestinal microflora in chemotherapeutic dysbacteriosis using bifidobacterial and lactobacterial autologous strains. *Zhurnal Mikrobiologii. Epidemiologii i Immunobiologii* 9:20- 25.
- Krieg, N.R. and Holt, J.G. 1984. *In: Bergey's manual of systematic bacteriology* vol. 1, p. 408. Williams and Wilkins, Baltimore, MD.

- Kruse, H.P., Kleessen, B., and Blaut, M. 1999. Effects of inulin on faecal bifidobacteria in human subjects. *Br. J. Nutr.* 82:375- 382.
- Kulbe, K.D., Schwab, U., and Gudernatsch, W. 1987. Enzyme-catalyzed production of mannitol and gluconic acid- product recovery by various procedures. *Ann. N.Y. Acad. Sci.* 506:552- 568.
- Kuriki, T., Yanase, M., Takata, H., Takesada, Y., Imanaka, T., and Okada, S. 1993. A new way of producing isomalto-oligosaccharide syrup by using the transglycosylation reaction of neopullulanase. *Appl. Environ. Microbiol.* 59:953- 959.
- Lawford, G.R., Kligerman, A., and Willams, T. 1979. Dextran biosynthesis and dextransucrase production by continuous culture of *Leuconostoc mesenteroides*. *Biotechnol. Bioeng.* 21:1121-1131.
- Levitt, M.D., Hirsh, P., Fetzer, C.A., Sheahan, M., and Levine, A.S. 1987. H<sub>2</sub> excretion after ingestion of complex carbohydrates. *Gastroenterology* 92: 383- 389.
- Link-Amster, H., Rochat, F., Saudan, K.Y., Mignot, O., and Aeschlimann, J.M. 1994. Modulation of a specific humoral immune response and changes in intestinal flora mediated through fermented milk intake. *FEMS Immunol. Med. Microbiol.* 10:55- 63.
- Lis, M., Shiroza, T., and Kuramitsu, H.K. 1995. Role of the C-terminal direct repeating units of the *Streptococcus mutans* glucosyltransferases in glucan binding. *Appl. Environ. Microbiol.* 61:2040-2042.
- Loesche, W.J. and Kornman, K.S. 1976. Production of mannitol by *Streptococcus mutans*. *Arch. Oral. Biol.* 21:551- 553.
- Loo, J.V., Cummings, J., Delzenne, N., Englyst, H., Franck, A., Hopkins, M., Kok, N., Macfarlane, G., Newton, D., Quigley, M., Roberfroid, M., Vliet, T.V., and Heuvel, E. 1999. Functional food properties of non-digestible oligosaccharides: a consensus report from the ENDO project (DGXII AIRII-CT94-1095). *Brit. J. Nutr.* 81: 121- 132.
- Lucey, C.A., and Condon, S. 1986. Active role of oxygen and NADH oxidase in growth and energy metabolism of *Leuconostoc*. *J. Gen. Microbiol.* 132:1789 – 1796.
- Lyons, T.P. 1987. Probiotics: an alternative to antibiotics. *Pig News Info.* 8:157-164.
- Macfarlane, G.T. and Cummings, J.H. 1999. Probiotics and prebiotics: can regulating the activities of intestinal bacteria benefit health? *Br. Med. J.* 318:999- 1003.
- Majamaa, H. and Isolauri, E. 1997. Probiotics; a novel approach in the management of food allergy. *J. Allergy Clin. Immunol.* 99:179- 185.
- Malin, M., Suomalainen, H., Saxelin, M., and Isolauri, E. 1996. Promotion of IgA immune response in patients with Crohn's disease by oral bacteriotherapy with *Lactobacillus* GG. *Ann. Nutr. Metab.* 40:137- 145.

- Marteau, P. and Rambaud, J.C. 1993. Potential for using lactic acid bacteria for therapy and immunomodulation in man. *FEMS Microbiol Rev.* 12:207- 220.
- Marteau, P., Vesa, T., and Rambaud, J.C. 1997. In R. Fuller (ed) *Probiotics 2: application and practical aspects.* p.65- 88. Chapman and Hall, London, U.K.
- Mattila-Sandholm, T., Blum, S., Collins, J.K., Crittenden, R., de Vos, W., Dunne, C., Fonda, R., Grenov, B., Isolauri, E., Kiely, B., Marteau, P., Morelli, L., Ouwehand, A., Reniero, R., Saarela, M., Salminen, S., Saxelin, M., Schiffrin, E., Shanahan, F., Vaughan, E., and von Wright, A. 1999. Probiotic: towards demonstrating efficacy. *Trends Food Sci. Technol.* 10:393- 399.
- McBain, A.J. and Macfarlane, G.T. 1997. Investigations of bifidobacterial ecology and oligosaccharide metabolism in a three-stage compound continuous culture system. *Scand. J. Gastroenterol. Suppl.* 222:32- 42.
- McIntosh, G.H., Royle, P.J., and Playne, M.J. 1999. A probiotic strain of *L. acidophilus* reduces DMH-induced large intestinal tumors in male Sprague-Dawley rats. *Nutr. Cancer* 35:153- 159.
- McKellar, R.C. and Modler, H.W. 1989. Metabolism of fructooligosaccharide by *Bifidobacterium* sp. *Appl. Microbiol. Biotechnol.* 31: 537-541.
- Meghrou, J., Euloge, P., Junelles, A.M., Ballongue, J., and Petitdemange, H. 1990. Screening of *Bifidobacterium* strains for bacteriocin production. *Biotechnol. Lett.* 12:575- 580.
- Mikelsaar, M., Mandar, R., and Sepp, E. 1998. Lactic acid microflora in the human microbial ecosystem and its development. In: S. Salminen and A. von Wright (eds.) *Lactic acid bacteria: microbiology and functional aspects.* p. 279-342. Marcel Dekker Inc., New York, N.Y.
- Miller, A.W., S.H. Eklund, and J.F. Robyt. 1986. Milligram to gram scale purification and characterization of dextransucrase from *Leuconostoc mesenteroides* NRRL B-512F. *Carbohydr. Res.* 147:119- 133.
- Miller, D.D. 1989. Calcium in the diet: food sources, recommended intakes, and nutritional bioavailability. *Adv. Food Nutr. Res.* 33:103- 156.
- Minami, Y., Yazawa, K., Tamura, Z., Tanaka, T., and Yamamoto, T. 1983. Selectivity of utilization of galactosyl oligosaccharides by bifidobacteria. *Chem. Pharm. Bull.* 31:1688-1691.
- Mohan, B., Kadirvel, R., Bhaskaran, M., and Natarajan, A. 1995. Effect of probiotic supplementation on serum/yolk cholesterol and on egg shell thickness in layers. *Br. Poult Sci.* 36:799- 803.
- Mohan, B., Kadirvel, R., Natarajan, A., and Bhaskaran, M. 1996. Effect of probiotic supplementation on growth, nitrogen utilization and serum cholesterol in broilers. *Br. Poult Sci.* 37:395-401.

- Molly, K., De Smet, I., Nollet, L., Vande Woestyne, M., Verstraete W. 1996. Effect of *Lactobacilli* on the ecology of the gastro-intestinal microbiota cultured in the SHIME reactor. *Microb. Ecol. Health. Dis.* 9:79- 89.
- Monchois, V., Arguello-Morales, M., and Russell, R.R.B. 1999a. Isolation of an active catalytic core of *Streptococcus downei* MFe28 GTF-I glucosyltransferase. *J. Bacteriol.* 181:2290- 2292.
- Monchois, V., Reverte, A., Remaud-Simeon, M., Monsan, P., and Willemot, R.M. 1998. Effect of *Leuconostoc mesenteroides* NRRL B-512F dextransucrase carboxy-terminal deletions on dextran and oligosaccharide synthesis. *Appl. Environ. Microbiol.* 64:1644-1649.
- Monchois, V., Willemot, R.M., Remaud-Simeon, M., Croux, C., and Monsan, P. 1996. Cloning and sequencing of a gene coding for a novel dextransucrase from *Leuconostoc mesenteroides* NRRL B-1299 synthesizing only  $\alpha(1-6)$  and  $\alpha(1-3)$  linkages. *Gene* 182:23- 32.
- Monchois, V., Willemot, Rene-Marc, W., and Monsan, P. 1999b. Glucansucrases: mechanism of action and structure-function relationships. *FEMS Microbiol. Rev.* 23:131-151.
- Monsan, P. and Paul, F. 1995. Oligosaccharide feed additives. *In: R.J. Wallace and A. Chesson (eds) Biotechnology in animal feeds and animal feeding.* p.233- 245. VCH Verlagsgesellschaft mbH, Weinheim, Germany.
- Mooser, G. and Iwaoka, K.R. 1989. Sucrose 6- $\alpha$ -glucosyl-transferase from *Streptococcus sobrinus*: characterization of a glucosyl-enzyme complex. *Biochemistry-US* 28:443- 449.
- Mooser, G., Hefta, S.A., Paxton, R.J., Shively, J.E., and Lee, T.D. 1991. Isolation sequence of an active-site peptide containing a catalytic aspartic-acid from 2 *Streptococcus sobrinus* alpha-glucosyltransferases. *J. Biol. Chem.* 266:8916- 8922.
- Morgan, A.J., Mul, A.J., Beldman, G., and Voragen, A.G.J. 1992. Dietary oligosaccharides: new insights. *Agro. Food Ind. Hi tec.* 11/12, 35- 38.
- Mozaffar, S., Nakanishi, K., Matsuno, R., and Kanukubo, T. 1984. Purification and properties of  $\beta$ -galactosidases from *Bacillus circulans*. *Agric. Biol. Chem.* 48:3053-3061.
- Nagendra, R., Viswanatha, S., Kumar, S.A., Murthy, B.K., Rao, S.V., 1995. Effect of feeding milk formula containing lactulose to infants on fecal bifidobacterial flora. *Nutr. Res.* 15:15- 24.
- Nakano, Y.J. and Kuramitsu, H.K. 1992. Mechanism of *Streptococcus mutans* glucosyltransferases-hybrid-enzyme analysis. *J. Bacteriol.* 174:5639- 5646.



- Naughton, P.J., Mikkelsen, L.L., and Jensen, B.B. 2001. Effects of nondigestible oligosaccharides on *Salmonella enterica* serovar *typimurium* and nonpathogenic *Escherichia coli* in the pig small intestine in vitro. *Appl. Environ. Microbiol.* 67:3391-3395.
- O'Riordan, K. and Fitzgerald, G.F. 1998. Evaluation of bifidobacteria for the production of antimicrobial compounds and assessment of performance in cottage cheese at refrigeration temperature. *J. Appl. Microbiol.* 85:103-114.
- O'Sullivan, D.J. and Kullen, M.J. 1998. Tracking of probiotic bifidobacteria in the intestine. *Int. Dairy Journal* 8:513-525.
- Ohta, A.M.O., Baba, S., Takizawa, T., Adachi, T., and Kimura, S. 1995. Effects of fructo-oligosaccharides on the absorption of iron, calcium, and magnesium in iron deficient anemic rat. *J. Nutr. Sci. Vitaminol.* 41:281-291.
- Oku, T., Tokunaga, T., and Hosoya, N. 1984. Nondigestibility of a new sweetener, Neosugar, in the rat. *J. Nutr.* 114: 1574-1581.
- Olentine, C.G. 1997. Income growth benefits poultry industry. *Poultry International* 36:3-31.
- Ooshima, T, A Izumitani, S Sobue, N Okahashi, and S Hamada. 1983. Non-cariogenicity of the disaccharide palatinose in experimental dental caries of rat. *Infect. Immun.* 39: 43-49.
- Otts, D. 1987. Regulation of dextransucrase secretion by proton motive force in *Leuconostoc mesenteroides*. Ph. D. Dissertation. Louisiana State University.
- Otts, D. and Day, D.F. 1988. Dextranase secretion in *Leuconostoc mesenteroides* depends on the presence of a transmembrane proton gradient. *J. Bacteriol.* 170:5006-5011.
- Oyarzabal, O.A. and Conner, D.E. 1995. *In vitro* fructooligosaccharide utilization and inhibition of *Salmonella* spp. by selected bacteria. *Poultry Sci.* 74: 1418-1425.
- Oyofe, B. A., DeLoach, J.R., Corrier, D.E., Norman, O.J., Ziprin, R.L., and Mollenuauer, H.H. 1989 Effect of carbohydrates on *Salmonella typhimurium* colonization in broiler chickens. *Avian Dis.* 33:531-534.
- Pascual, M., Hugas, M., Badiola, J.I., Monfort, J.M., and Garriga, M. 1999. *Lactobacillus salivarius* CTC2197 prevents *Salmonella enteritidis* colonization in chickens. *Appl. Environ. Microbiol.* 65:4981-4986.
- Paul, F., Lopez-Munguia, A., Remaud, M., Pelenc, V., and Monsan, P. 1992. Method for the production of  $\alpha$ -1,2 oligodextrans using *Leuconostoc mesenteroides* B-1299. US Patent 5,141,858.

- Paul, F., Oriol, E., Auriol, D., and Monsan, P. 1986. Acceptor reaction of a highly purified dextransucrase with maltose and oligosaccharides. application to the synthesis of controlled-molecular-weight dextrans. *Carbohydr. Res.* 149:433-441.
- Pelto, L., Isolauri, E., Lilius, E.M., Nuutila, J., and Salminen, S. 1998. Probiotic bacteria down-regulate the milk-induced inflammatory response in milk-hypersensitive subjects but have an immunostimulatory effect in healthy subjects. *Clin. Exp. Allergy* 28:1474-1479.
- Perdigon, G., Alvarez, S., and Pesce de Ruiz Holgado, A. 1991. Immunoadjuvant activity of oral *Lactobacillus casei*: influence of dose on the secretory immune response and protective capacity in intestinal infections. *J. Dairy Res.* 58:485- 496.
- Perdigon, G., Alvarez, S., Rachid, M., Aguero, G., and Gobatto, N. 1995. Immune system stimulation by probiotics. *J. Dairy Sci.* 78:1597- 1606.
- Perdigon, G., de Macias, M.E., Alvarez, S., Oliver, G., and de Ruiz Holgado, A.A. 1986. Effect of perorally administered *lactobacilli* on macrophage activation in mice. *Infect. Immun.* 53:404- 410.
- Peterson, W.H. and Fred, E.B. 1920. Fermentation of fructose by *Lactobacillus pentoaceticus*, N.SP. *J. Biol. Chem.* 41:431- 450.
- Pettoello Mantovani, M., Guandalani, S., Ecuba, P., Corvino, C., Dimartino, L. 1989. Lactase malabsorption in children with symptomatic *Giardia lamblia* infection. *J. Pediatr. Gastroenterol.* 9:295- 300.
- Pool-Zobel, B.L., Bertram, B., Knoll, M., Lambetz, R., Neudecker, C., Schillinger, U, Schmezer, P., and Holzappel, W.H. 1993. Antigenotoxic properties of lactic acid bacteria in vivo in the gastrointestinal tract of rats. *Nutr. Cancer* 20:271- 281.
- Pouwels, P.H., Leer, R.J., and Boersman, W.J. 1996. The potential of *Lactobacillus* as a carrier for oral immunization: development and preliminary characterization of vector systems for targeted delivery of antigens. *J. Biotechnol.* 44:183- 192.
- Prakash, S., Suyama, K., Itoh, T., and Adachi, S. 1987. Oligosaccharide formation by *Trichoderma harzianum* in lactose-containing medium. *Biotechnol. Lett.* 9:249- 252.
- Pszczola, D.E. 1988. Production and potential food applications of cyclodextrins. *Food Technol.* 42(1): 96-100.
- Rasic, J.L. and Kurmann, J. A. 1983. *In: Bifidobacteria and their role.* p.9-50. Birkhauser Verlag, Basel, Switzerland.
- Ray, B.1996. *In: Fundamental Food Microbiology.* p. 182. CRC press, Inc., Boca Raton, FL.
- Reddy, B.S. 1998. Prevention of colon cancer by pre-and probiotics:evidence from laboratory studies. *Br. J. Nutr.* 80(suppl):S219- S223.

- Reddy, B.S., Hamid, R., and Rao, C.V. 1997. Effect of dietary oligofructose and inulin on colonic preneoplastic aberrant crypt foci inhibition. *Carcinogenesis* 18:1371- 1374.
- Remaud, M., Paul, F., and Monsan, P. 1992. Characterization of  $\alpha$ -1,3 branched oligosaccharides synthesized by acceptor reaction with the extracellular glucosyltransferases from *L. mesenteroides* NRRL B-742. *J. Carbohyd. Chem.* 11: 359-378.
- Remaud-Simeon, M., Lopez-Munguia, A., Pelec, V., Paul, F., and Monsan, P. 1994. Production and use of glucosyltransferases from *Leuconostoc mesenteroides* NRRL B-1299 for the synthesis of oligosaccharides containing  $\alpha$ -1,2 linkages. *Appl. Biochem. Biotechnol.* 44: 101-117.
- Remaud-Simeon, M., Willemot, R-M., Sarçabal, P., de Montalk, G.P. and Monsan, P. 2000. Glucansucrases: molecular engineering and oligosacchride synthesis. *J. Mol. Catal. B- Enzym.* 10:117-128.
- Roberfroid, M. 2000. Probiotics and prebiotics: are they functional foods?. *Am J Clin Nutr* 71(suppl):1682S-7S.
- Roberfroid, M.B. 1998. Prebiotics and synbiotics: concepts and nutritional properties. *Br. J. Nutr.* 80 (suppl. 2):S197- S202.
- Roberfroid, M.B. and Delzenne, N.M. 1998. Dietary fructans. *Annu. Rev. Nutr.* 18:117-143.
- Roberfroid, M.B., Van Loo, J.A.E., and Gibson, G.R. 1998. The bifidogenic nature of chicory inulin and its hydrolysis products. *J. Nutr.* 128: 11-19.
- Robynt, J. and Ecklund, S. 1983. Relative, quantitative effects of acceptors in the reaction of *Leuconostoc mesenteroides* B-512F dextranucrase. *Carbohydr. Res.* 121:279-286.
- Robynt, J. and Walseth, T. 1979. Production, purification, and properties of dextranucrase from *Leuconostoc mesenteroides* NRRL B-512F. *Carbohydr. Res.* 68:95-111.
- Robynt, J.F. 1986. Dextran. *In: H.F. Mark, N.M. Bikales, C.G. Overberger, and G. Menges (eds.) Encyclopedia of Polymer Science and Engineering.* Vol. 4 p. 752- 767. John Wiley & Sons, New York, NY.
- Robynt, J.F. and Corrigan, A.J. 1977. The mechanism of dextranucrase action. Activation of dextranucrase from *Streptococcus mutans* OMZ 176 by dextran and modified dextran and the non existence of the primer requirement for the synthesis of dextran. *Arch. Biochem. Biophys.* 183:726- 731.
- Robynt, J.F. and Martin, P.J. 1983. Mechanism of synthesis of D-glucans by D-glucosyltransferases from *Streptococcus mutans* 6715. *Carbohydr. Res.* 113:301- 315.
- Robynt, J.F. and Mukerjea, R. 1994. Separation and quantitative determination of nanogram quantities of maltodextrins and isomaltodextrins by thin-layer chromatography. *Carbohydr. Res.* 251:187- 202.

- Roby, J.F. and Taniguchi, H. 1976. The mechanism of dextransucrase action. biosynthesis of branch linkages by acceptor reactions with dextran. Carbohydr. Res. 88:107- 117.
- Roby, J.F. and Walseth, T.F. 1978. The mechanism of acceptor reactions of *Leuconostoc mesenteroides* NRRL B-512F dextransucrase. Carbohydr. Res. 61:433- 435.
- Roby, J.F., Kimble, B.K., and Walseth, T.F. 1974. The mechanism of dextransucrase action. Direction of dextran biosynthesis. Arch. Biochem. Biophys. 165:634- 640.
- Rolfe, R.D. 2000. The role of probiotic cultures in the control of gastrointestinal health. J Nutr. 130(suppl): 396S- 402S.
- Romano, A.H. 1987. Microbial sugar transport systems and their importance in biotechnology. Trends Biotechnol. 36:679- 683.
- Romano, A.H., Trifone, J.D., and Brustolon, M. 1979. Distribution of the phosphoenolpyruvate:glucosephosphotransferase system in fermentative bacteria. J. Bacteriol. 139:93 – 97.
- Roos, N. and Katan M.B. 2000. Effects of probiotic bacteria on diarrhea, lipid metabolism, and carcinogenesis: a review of papers published between 1988 and 1998. Am. J. Clin. Nutr. 71: 405- 411.
- Roper, H. and Koch, H. 1988. New carbohydrate-derivatives for biotechnical and chemical processes. Starch 40:453- 459.
- Rowland, I.R., Rumney, C.J., Coutts, J.T., and Lievens, L.C. 1998. Effect of *Bifidobacterium longum* and inulin on gut bacterial metabolism and carcinogen-induced aberrant crypt foci in rats. Carcinogenesis 19:281- 285.
- Russell, R.R.B. 1990. Molecular-genetics of glucan metabolism in oral *Streptococci*. Arch. Oral. Biol. 35(suppl):53S- 58S.
- Saavedra, J.M., Bauman, N.A., Oung, I., Perman, J.A., and Yolken, R.H. 1994. Feeding of *Bifidobacterium bifidum* and *Streptococcus thermophilus* to infants in hospital for prevention of diarrhea and shedding of rotavirus. Lancet 344: 1046- 1049.
- Salou, P., Loubiere, P., and Pareilleux, A. 1994. Growth and energetics of *Leuconostoc oenos* during cometabolism of glucose with citrate or fructose. Appl. Environ. Microbiol. 60:1459- 1466.
- Sanders, M.E. 1993. Summary of the conclusions from a consensus panel of experts on health attributes on lactic cultures: significance to fluid milk products containing cultures. J. Dairy Sci. 76:1819- 1828.
- Sapico, V., and Anderson, R.L. 1967. An adenosine 5'-triphosphate:hexose 6-phosphotransferase specific for D-mannose and D-fructose from *Leuconostoc mesenteroides*. J. Biol. Chem. 242:5082- 5092.

- Schiffirin, E., Rochat, F., Link-Amster, H, et al. 1995. Immunomodulation of blood cells following the ingestion of lactic acid bacteria. *J. Dairy Sci.* 78:491- 497.
- Schwartz, M. 1987. *In*: F.C. Neidhardt, R. Curtiss III, J.L. Ingraham, E.C.C. Lin, K.B. Low, B. Magasanik, W.S. Reznikoff, M. Riley, M. Schaechter, and H.E. Umbarger (eds.), *Escherichia coli* and *Salmonella*: Cellular and Molecular Biology, 2nd ed., p. 1484. ASM press, Washington, D.C.
- Seymour, F., Knapp, R., Chen, C., Jeanes, A. and Bishop, S. 1979a. Structural analysis of dextrans containing 4-O- $\alpha$ -D-glucosylated  $\alpha$ -D-glucopyranosyl residues at the branch points, by use of <sup>13</sup>C-nuclear magnetic resonance spectroscopy and gas-liquid chromatography-mass spectrometry. *Carbohydr. Res.* 75:275.
- Seymour, F.R. Chen, E.C.M., and Bishop, S.H. 1979b. Methylation structural analysis of unusual dextrans by combined gas-liquid chromatography-mass spectrometry. *Carbohydr. Res.* 68, 113.
- Shiomi, N. 1978. Isolation and identification of 1-kestose and neokestose from onion bulbs. *J. Fac. Agric. Hokkaido Univ.* 58:548- 556.
- Shiomi, N., Yamada, J., and Izawa, M. 1976. Isolation and identification of fucto-oligosaccharides in roots and asparagus. *Agr. Biol. Chem.* 40:567- 575.
- Sidebotham, R.L. 1974. Dextrans. *Adv. Carbohydr. Chem. Biochem.* 30:371- 444.
- Simpson, C.L., Cheetham, N.W.H., Giffard, P.M., and Jacques, N.A. 1995. 4 glucosyltransferases, GTFJ, GTFK, GTFL and GTFM, from *Streptococcus salivarius* ATCC 25975. *Microbiology* 141:1451- 1460.
- Singh, J., Rivenson, A., Tomita, M., Shimamura, S., Ishibashi, N., and Reddy, B.S. 1997. *Bifidobacterium longum*, a lactic acid-producing intestinal bacterium inhibits colon cancer and modulates the intermediate biomarkers of colon carcinogenesis. *Carcinogenesis* 18:833- 841.
- Smiley, K., Morey, E., Boundy, J. and Plattner, R. 1982. A simplified method for preparing linear isomalto-oligosaccharides. *Carbohydr. Res.* 108: 279-283.
- Smithson, K.W., Miller, D.B., Jacobs, L.R., and Gray, G.M. 1981. Intestinal diffusion barrier: unstirred water layer or membrane surface mucous coat?. *Science* 214:1241-1244.
- Sneath, P.H.A., Mair, N.S., Sharpe, M.E., and Holt, J.G. 1984. *In*: Bergey's manual of systematic bacteriology vol. 2, p. 1418. Williams and Wilkins, Baltimore, MD.
- Soetaert, W., Buchholz, K., and Vandamme, E.J. 1995. Production of D-mannitol and D-lactic acid by fermentation with *Leuconostoc mesenteroides*. *Agro. Food Ind. Hi Tec.* Jan./Feb.: 41-44.

- Sorrels, K.M. and Speck, M.L. 1970. Inhibition of *Salmonella gallinarum* by culture filtrates of *Leuconostoc citrovorum*. J. Dairy Sci. 53:239- 241.
- Speigel, J.E., Rose, R., Karabell, P., Frankos, V.H., and Schmitt, D.F. 1994. Safety and benefits of fructooligosaccharides as food ingredients. Food Technol. 48:85- 89.
- Starvic, S. 1987. Microbial colonization control of chicken intestine using defined cultures. Food Technol. 41: 93– 98.
- Tannock, G.W., Munro, K., Harmsen, H.J.M., Welling, G.W., Smart, J., Gopal, P.K. 2000. Analysis of the fecal microflora of human subjects consuming a probiotic product containing *Lactobacillus rhamnosus* DR20. Appl. Environ. Microbiol. 66:2578- 2588.
- Tomomatsu, H. 1994. Health effects of oligosaccharides. Food Technol. 48(10): 61-65.
- Tramer, J. 1966. Inhibitory effect of *Lactobacillus acidophilus*. Nature 211:204- 205.
- Tsuchiya, H.M., Koepsell, H.J., Corman, J., Bryant, G., Bogard, M.O. Feger, V.H., and Jackson, R.W. 1952. The effect of certain cultural factors on production of dextransucrase by *Leuconostoc mesenteroides*. J. Bacteriol. 64:521-527.
- Valette, P., Pelenc, V., Djouzi, Z., Andrieux, C., Paul, F., Monsan, P. and Szytit, O. 1993. Bioavailability of new synthesized glucooligosaccharides in the intestinal tract of gnotobiotic rats. J. Sci. Food Agric. 62:121- 127.
- Vandamme, E.J., J. Van Loo, and A. De Laporte. 1987. Dynamics of sucrose phosphorylase formation in *Leuconostoc mesenteroides* fermentations. Biotechnol. Bioeng. 29: 8- 15.
- Vickermann, M.M., Sulavik, M.C., Nowak, J.D., Gardner, N.M., Jones, C.W., and Clewell, D.B. 1997. Nucleotide sequence analysis of the *Streptococcus gordonii* glucosyltransferase gene, gtfG. DNA Sequence 7:83- 95.
- Vincent, J.G., Veonett, R.C., and Riley, R.G. 1959. Antibacterial activity associated with *Lactobacillus acidophilus*. J. Bacteriol. 78:477- 484.
- Waltham, M.S. 1998. Roadmaps to Market: Commercializing Functional Foods and Nutraceuticals, Decision Resources, Inc., p.5.
- Wang, X. and Gibson, G.R. 1993. Effects of the in vitro fermentation of oligofructose and inulin by bacteria growing in the human large intestine. J. Appl. Bacteriol. 75:373- 380.
- Weaver, C.M. and Plawecki, K.L. 1994. Dietary calcium:adequacy of a vegetarian diet. Am. J. Clin. Nutr. 59(suppl):S1238- S1241.
- Weimberg, R., and Doudoroff, M. 1954. Studies with three bacterial sucrose phosphorylases. J. Bacteriol. 68: 381- 387.
- Wheater, D.M., Hirsch, A. and Mattick, A.T.R. 1952. Possible identity of 'lactobacillin' with hydrogen peroxide produced by *lactobacilli*. Nature 170:623- 626.

Whittenbury, R. 1964. Hydrogen peroxide formation and catalase activity in the lactic acid bacteria. *J. Gen. Microbiol.* 35:13- 26.

Wisniak, J. and Simon, R. 1979. Hydrogenation of glucose, fructose, and their mixtures. *Ind. Eng. Chem. Prod. Res. Dev.* 18:50.

Yasuda, E.H, Takaku, H., and Matsumoto, H. 1986. Japanese Patent, 61-212296.

Yasui, H., Kiyoshima, J., and Ushijima, H. 1995. Passive protection against rotavirus-induced diarrhea of mouse pups born to and nursed by dams fed *Bifidobacterium breve* YIT4064. *J. Infect. Dis.* 172:403- 409.

Yoneyama, M., Shibuya, T., and Miyake, T. 1992. Saccharides sous forme de poude, preparation et utilisations. French Patent 2,677,359.

Yoo, S.H., Kweon, M.R., Kim, M.J., Auh, J.H., Jung, D.S., Kim, J.R., Yook, C., Kim, J.W. and Park, K.H. 1995. Branched oligosaccharides concentrated by yeast fermentation and effectiveness as a low sweetness humectant. *J. Food Sci.* 60:516-519.

Yoo, SK. 1997. The production of glucooligosaccharides by *Leuconostoc mesenteroides* ATCC 13146 and *Lipomyces starkeyi* ATCC 74054. Ph.D. Dissertation, Louisiana State University.

**APPENDIX A: <sup>13</sup>C N.M.R. DATA**

Assignment	Branched (d.p. 6) <sup>a</sup>	Maltose	Panose
C-1→4	100.7 100.6	100.7 100.6	100.7
C-1→3	100.15		
C-1→6	98.87 98.65 98.55		99.06
C-1β	96.7	96.8	96.8
C-1α	92.8	92.9	92.9
C-3→1	81.4		
C-4→1	78.5 78.2	78.2 78.0	78.6 78.3
C-3β <sup>b</sup>	77.07	77.2	77.2
C-5β <sup>b</sup>	75.4	75.5	75.6
C-2β <sup>b</sup>	74.9	75.1	75.1
C-6→1	66.9 66.25		66.9
C-6	61.7 61.6 61.4 61.3	61.8 61.6	61.9 61.8 61.6

- a. Branched hexasaccharide (degree of polymerization; 6) produced by acceptor reaction from *L. mesenteroides* NRRL ATCC 13146 (Adopted from Remaud *et al.* 1992)
- b. These chemical shifts correspond to the free carbon C-2β, C-3β, C-5β of the glucose residue (β anomer) located at the reducing end.



## APPENDIX B: STRUCTURES OF OLIGOSACCHARIDES

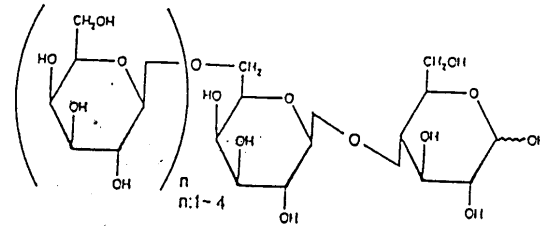
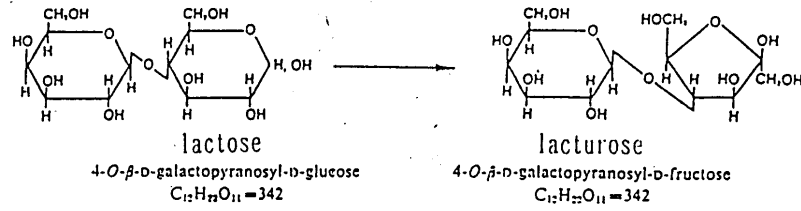

galactooligosacchrides

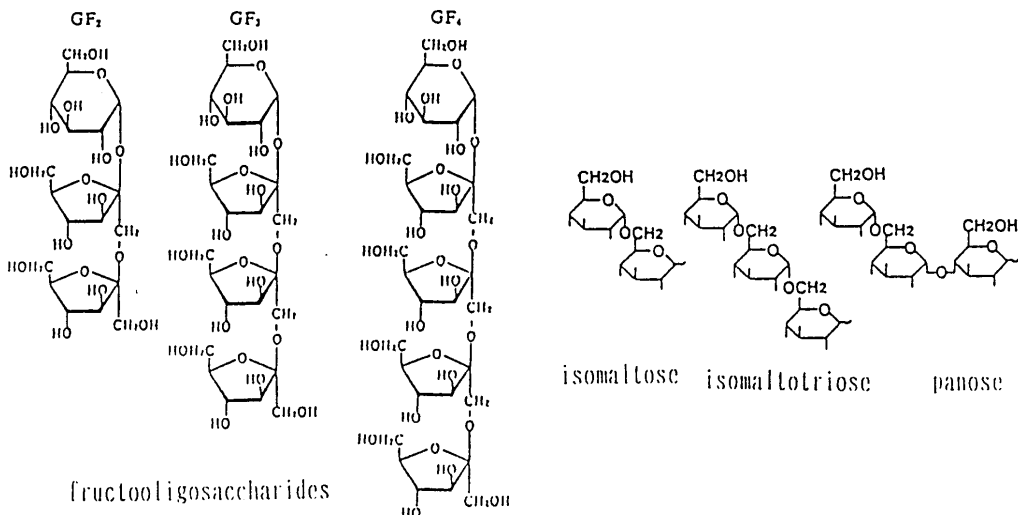
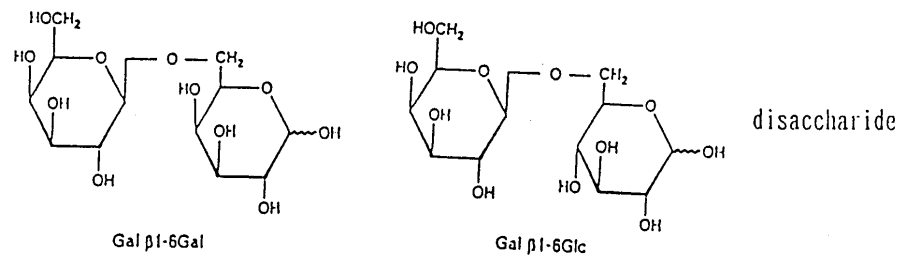

## VITA

Chang-Ho Chung was born in Ansong, Kyungki-do, Republic of Korea, on November 21, 1969. After graduating from Paichai High School, he entered Sejong University in 1989 where he obtained his master and bachelor of science degree in food science and technology in 1995 and 1997, respectively. He began his graduate study at Louisiana State University, Baton Rouge in August 1998. He will receive the degree of Doctor of Philosophy at the May Commencement, 2002.