

## **N O T I C E**

THIS DOCUMENT HAS BEEN REPRODUCED FROM  
MICROFICHE. ALTHOUGH IT IS RECOGNIZED THAT  
CERTAIN PORTIONS ARE ILLEGIBLE, IT IS BEING RELEASED  
IN THE INTEREST OF MAKING AVAILABLE AS MUCH  
INFORMATION AS POSSIBLE

(NASA-CR-165015) A PRELIMINARY ESTIMATE OF  
FUTURE COMMUNICATIONS TRAFFIC FOR THE  
ELECTRIC POWER SYSTEM (Jet Propulsion Lab.)  
73 p HC A04/HF A01 CSCL 10B

N82-13493

Unclas  
08465

63/44

# A Preliminary Estimate of Future Communications Traffic for the Electric Power System

Roger M. Barnett



October 15, 1981

Prepared for  
U.S. Department of Energy  
Through an Agreement with  
National Aeronautics and Space Administration  
by  
Jet Propulsion Laboratory  
California Institute of Technology  
Pasadena, California

# **A Preliminary Estimate of Future Communications Traffic for the Electric Power System**

**Roger M. Barnett**

October 15, 1981

Prepared for  
**U.S. Department of Energy**  
Through an Agreement with  
**National Aeronautics and Space Administration**  
by  
**Jet Propulsion Laboratory**  
California Institute of Technology  
Pasadena, California

Prepared by the Jet Propulsion Laboratory, California Institute of Technology, and sponsored by the U.S. Department of Energy, Office of Electric Energy Systems, through an agreement with the National Aeronautics and Space Administration.

The work is a subtask of the Communications and Control for Electric Power Systems Project.

This report was prepared as an account of work sponsored by the United States Government. Neither the United States nor the United States Department of Energy, nor any of their employees, nor any of their contractors, subcontractors, or their employees, makes any warranty, express or implied, or assumes any legal liability or responsibility for the accuracy, completeness or usefulness of any information, apparatus, product or process disclosed, or represents that its use would not infringe privately owned rights.

## ABSTRACT

This report presents the results of a study to promote diverse new generator technologies using renewable energy, and to improve operational efficiency throughout the existing electric power systems. A description of a model utility has been synthesized, and, by extrapolation of current and emerging practices, an estimate has been made of the information transfer requirements imposed by incorporation of dispersed storage and generation technologies and implementation of more extensive energy management methods. The estimates given in this report are preliminary, speculative, and based on the functional and structural characteristics of a hypothetical utility. This report provides an example of possible traffic for an assumed system, and an approach that can be applied to other systems, control configurations, or dispersed storage and generation penetrations.

## PREFACE

This work was sponsored by the U.S. Department of Energy through an interagency agreement, DE-AI01-79ET29372, with the National Aeronautics and Space Administration (Task RD 152, Amendment, 203).

## ABBREVIATIONS AND ACRONYMS

ACE	area control error
AGC	automatic generation control
ANSI	American National Standards Institute
BPS	bulk power substation
b/s	bits per second
CATV	cable television
CO	carbon monoxide
DAC	distribution automation control
dc	direct current
DSS	distribution substation
DSSC	distribution substation controller
DSG	dispersed storage and generation
ECC	energy control center
EMS	energy management system
FCC	Federal Communications Commission
IEEE	Institute of Electrical and Electronic Engineers
JPL	Jet Propulsion Laboratory
kb/s	kilobits per second
kHz	kilohertz
kV	kilovolt
KVAR	kilovolt-ampere reactive
kW	kilowatt
LMSS	Land Mobile Satellite System
LTC	load tap change
Mb/s	megabits per second
MHz	megahertz

## ABBREVIATIONS AND ACRONYMS (Cont'd)

MW	megawatt
MWh	megawatt hour
NO <sub>x</sub>	oxides of nitrogen
PLC	powerline carrier
RTU	remote terminal unit
SOE	sequence of events
SO <sub>x</sub>	oxides of sulfur
UHF	ultrahigh frequency
VAR	volt-ampere reactive
VHF	very high frequency



## CONTENTS

I.	SUMMARY . . . . .	1-1
A.	FUNCTIONAL OPERATION . . . . .	1-1
B.	CONCLUSIONS AND RECOMMENDATIONS . . . . .	1-2
II.	INTRODUCTION . . . . .	2-1
A.	OBJECTIVE . . . . .	2-1
B.	APPROACH . . . . .	2-1
III.	DESCRIPTION OF THE SYNTHETIC UTILITY . . . . .	3-1
A.	OVERALL CHARACTERISTICS . . . . .	3-1
B.	ONE-LINE DIAGRAMS . . . . .	3-9
C.	DISTRIBUTION SYSTEM MODEL . . . . .	3-14
IV.	FUNCTIONAL ANALYSIS . . . . .	4-1
A.	THE SYNTHETIC UTILITY . . . . .	4-1
B.	THE ENERGY MANAGEMENT SYSTEM . . . . .	4-1
V.	COMMUNICATIONS NETWORK . . . . .	5-1
A.	DATA-FLOW CHANNELS . . . . .	5-1
B.	MESSAGE PROTOCOL . . . . .	5-1
VI.	COMMUNICATIONS REQUIREMENTS . . . . .	6-1
A.	ON-LINE OPERATIONAL REQUIREMENTS: BULK POWER SYSTEM . . . . .	6-1
B.	ON-LINE OPERATIONAL REQUIREMENTS: DISTRIBUTION SYSTEM . . . . .	6-8
C.	SUPPORT AND ADMINISTRATIVE REQUIREMENTS . . . . .	6-17
VII.	TRAFFIC REQUIREMENTS ANALYSIS . . . . .	7-1
A.	SUMMARY . . . . .	7-1
B.	CONCLUSIONS AND RECOMMENDATIONS . . . . .	7-4

## CONTENTS (Cont'd)

REFERENCES . . . . .	8-1
----------------------	-----

### Figures

2-1. Simplified Power System Showing Parallel with Energy Management System Hierarchy . . . . .	2-3
3-1. Synthetic Utility Transmission System . . . . .	3-2
3-2. 345/138-kV Subtransmission System . . . . .	3-3
3-3. 138-kV Subtransmission System . . . . .	3-4
3-4. 69-kV Subtransmission System . . . . .	3-5
3-5. 12-kV Distribution System . . . . .	3-6
3-6. Generation Plant D One-Line Diagram . . . . .	3-10
3-7. Bulk Power Substation C One-Line Diagram . . . . .	3-12
3-8. Distribution Substation One-Line Diagram . . . . .	3-13
4-1. Functions and Interfaces of Model Electric Utility . . . . .	4-2
4-2. Functions and Interfaces for the Energy Control Center . . . . .	4-3
4-3. Functions and Interfaces for the Distribution Substation Controller . . . . .	4-6
5-1. Energy Control Center Data-Flow Diagram . . . . .	5-2
5-2. Distribution Substation Data-Flow Diagram . . . . .	5-3
6-1. Energy Control Center Data-Flow Diagram . . . . .	6-9
6-2. Representative DSSC Data-Flow Diagram . . . . .	6-18

### Tables

1-1. Typical Data Requirements: ECC Links . . . . .	1-3
1-2. Traffic Summation for Typical Distribution Devices to Substation Controller . . . . .	1-3
1-3. Summary of Synthetic Utility Control Data Exchange . . . . .	1-4
3-1. Model Utility Generation Plant Description . . . . .	3-7

CONTENTS (Cont'd)

3-2.	Synthetic Utility Major Characteristics . . . . .	3-8
3-3.	Dispersed Storage Generation Derivation . . . . .	3-9
3-4.	Bulk Supply Substation Data . . . . .	3-11
4-1.	Data Collection Requirements for the Operating Systems . . .	4-5
4-2.	Polling Rates for Data Acquisition . . . . .	4-7
5-1a.	Message Format Summary: Standard Format . . . . .	5-5
5-1b.	Message Types . . . . .	5-5
5-2.	Application of Remote-to-Master-Response Messages . . . . .	5-6
6-1.	Scanning Requirements: Bulk Power Generation . . . . .	6-2
6-2a.	Data Message Requirements, Generation Plant D: Oil-Fired Units RTU . . . . .	6-3
6-2b.	Data Message Requirements, Generation Plant D: Switchyard RTU . . . . .	6-4
6-3.	Scanning Requirements: Transmission/Subtransmission . . . . .	6-6
6-4.	Data Message Requirements: Bulk Power Substation C . . . . .	6-7
6-5.	Scanning Requirements: Distribution Substation . . . . .	6-11
6-6.	Data Message Requirements: Distribution Substation . . . . .	6-12
6-7.	Scanning Requirements: Dispersed Storage Generation . . . . .	6-13
6-8.	Data Message Requirements: Dispersed Storage Generation . . .	6-14
6-9.	Data Message Requirements: ECC to DSSC . . . . .	6-16
6-10.	Mobile Unit Channel Analysis . . . . .	6-20
7-1.	Traffic Summation for Typical Distribution Devices to Substation Controller . . . . .	7-1
7-2.	Typical Data Requirements: ECC Links . . . . .	7-3
7-3.	Voice/Data Support Channel Summary . . . . .	7-5
7-4.	Synthetic Utility Control Data Exchange Summary . . . . .	7-5

## SECTION I

### SUMMARY

Operations in existing electric power systems depend on the use of communications to enable monitor and control of system functions over wide geographic areas. This is especially true for the bulk power generation and transmission systems. Mounting economic pressures, decreasing availability of traditional energy sources, and an increasing need to reduce dependence on foreign fuels are motivating attempts to introduce diverse new generator technologies using renewable energy and to improve operational efficiency wherever possible throughout the system. These trends are expected to have a large impact on the amount and kind of communications support required by the nation's utilities.

Some indication of expected communications requirements can be gained by examining and comparing the evolving needs of a hypothetical representative utility with the characteristics of available communications technologies. A description of such a model utility has been synthesized, and, by extrapolation of current and emerging practices, an estimate has been made of the information transfer requirements imposed by incorporation of dispersed storage and generation (DSG) technologies and implementation of more extensive energy management methods.

#### A. FUNCTIONAL OPERATION

The model utility employed serves about one million customers. It has a generating capacity of 12,130 MW, 5% of which is provided by DSG units in sizes ranging from 75 kW or less, to 20 to 30 MW. The peak system load is 8085 MW. Automatic Generation Control (AGC) is used on all six bulk generating stations and on intermediate and large DSGs. It is assumed that control of the distribution system is automated and that 60% of the customers are subject to load management. Selection of the employed control hierarchy is based on considerations outlined in Reference 1.

A high-level functional description of the model utility has been constructed. From this functional set, and the chosen control structure, a more detailed listing of the functions to be handled at each control level has been developed. The information exchange interfaces among the Energy Control Center (ECC), Distribution Substation Controller (DSSC), and other system elements also were developed.

The measurements that are required from the utility's operating system to support the functions noted above were identified, and time intervals were specified for various data types. The most rapid scan interval ranged from 2 s for those remote terminal units (RTUs) involved in AGC, to 30 s for RTUs involved in distribution automation control (DAC), to 12 min for operation scheduling. From these measurements and scan intervals, information flow between each of the master and remote stations has been estimated. Measurements originate at the RTUs, and flow to the ECC and DSSCs. The message protocol for master/remote communications used to estimate data transfer requirements is under consideration by the Institute of Electrical and

Electronic Engineers (IEEE), Automatic and Supervisory Systems Subcommittee (Reference 2). Operation in the half duplex, poll-and-response mode is specified, using a standard message format. One hundred bits of preamble time (characteristic of a high-speed link) were assumed for each message, although other allocations can be substituted as appropriate for the communications technology to be used.

For the hypothetical utility operation as outlined in the preceding paragraphs, estimates of data exchange requirements are summarized in Tables 1-1 through 1-3. In developing these requirements, no allowance has been made for such factors as message spacing, turnaround time, coding, or error correcting. Hence, the rates presented do not constitute link performance specifications, but rather represent one step in their development. They do provide a rough indication of the actual data rates to be supported by the communications links, and can be used as one criterion against which alternative mechanizations can be evaluated. Table 1-1 shows typical exchange rates over the links connected with the ECC. Table 1-2 lists data transfer rates at a typical distribution substation, analyzed by function rather than place of origin. If the larger DSGs are excluded, data exchange rates at the substation average 190 b/s per connected feeder. Table 1-3 summarizes the data exchange traffic for monitor and control of the total utility. Existing utilities primarily use remote monitor and control for their bulk power generation and transmission systems. Thus, extension of this control to the distribution system might increase communications traffic threefold. Requirements are strongly impacted by the monitoring needed to support distribution automation. Load management by block addressing and meter reading have only a small effect.

The impact on communications traffic made by incorporating advanced technologies, in the form of DSGs and distribution automation, is clearly on the distribution system, converging on the DSSC. The traffic generated by DSGs depends directly on the number served and the control functions implemented. Small units (75 kW or less) have a modest impact on communications requirements, but the impact of larger units, subject to automatic generation control, is substantial.

## B. CONCLUSIONS AND RECOMMENDATIONS

Some general comments can be made regarding the suitability of various candidate communications technologies for supporting this traffic. No distinct choice emerges because all candidates have deficiencies and concerns, either technical or institutional, and the best choice for a given situation may depend on factors not considered in this study. However, technology beyond the current state of the art is clearly desirable for any of the candidates. The general comments are:

- (1) The total DSSC requirements (see Table 1-2) are well beyond current Powerline Carrier/Ripple (PLC/Ripple) communications system capability, which is less than 100 b/s. At least an order of magnitude improvement in data rate is needed.

Table 1-1. Typical Data Requirements: ECC Links

ECC Link To	Bit Rate, kb/s
Regional Pool	0.5
Scheduling	4.0
Intertie Terminus	1.0
Generation Plant D	20.0
Switching Center	1.0
Bulk Power Substation C	3.3
Large Industrial Customer	0.1
DSSC	<u>0.1</u>
	Total 30.0

Table 1-2. Traffic Summation for Typical Distribution Devices to Substation Controller

Function	Data Rate, b/s
Distribution Automation	850
Load Management	40
Small DSG Management (15 Units)	190
Meter Reading	<u>70</u>
	Subtotal 1150
Large/Intermediate DSG Management (3 Units)	<u>1200</u>
	Total 2350

Table 1-3. Summary of Synthetic Utility Control Data Exchange

Function	Data Rate, kb/s
Bulk Power Generation	46
Transmission/Subtransmission	44
ECC to DSSC	8
Distribution	222
(1) Distribution Automation	170
(2) DSG (>1 MW) Control (55 Total)	22
(3) DSG (~75 kW) Control (1800 Total)	23
(4) Load Management	7
Total	320

- (2) The switched telephone network is precluded by the long interrogation delay for each connection (typically  $\geq 5$  s) for functions requiring multiple RTU polling at intervals of 2 to 10 s.
- (3) The traffic rates and volume are low relative to the capabilities of high-speed technologies such as coaxial cable, optical fibers, or communications satellites; therefore, sharing with other services is indicated.
- (4) Current commercial satellite service to the distribution system is not practical because of the large, costly, ground terminals (4 1/2-m antenna, \$75K per site) needed for each of the distribution RTUs. However, current satellite service can be a reasonable alternative for the bulk power systems and larger DSG units. Future satellites could be designed to make distribution system service practical. Planning for such satellites is being done under the NASA Land Mobile Satellite System (LMSS) program.

The major drivers which are expected to lead to expanded communications or utilization of new technologies are in the near-term future. Nevertheless, there are a number of actions that can be undertaken now which will help prepare for that future. The following are recommendations for follow-on activities:

- (1) A much more descriptive and realistic model of the distribution system should be developed. This model can be used to better assess the impact of various operational alternatives, to better explore the issues of various communications alternatives, and to develop more realistic communications and control strategies.
- (2) Identification of the peculiar monitor and control requirements of each of the candidate DSG technologies. These can then be used to generate appropriate telemetry lists.
- (3) Identification of the special communications and control requirements of the major transmission utilities or agencies such as TVA, Bonneville, etc. These were not included in this study, which would be more complete by their addition.
- (4) Formulation of an experimental program for investigating, in partnership with a utility, the key issues regarding the support of monitor and control traffic with communications satellites.
- (5) Identification of other potential users having similar requirements who might share a high-speed communications network and estimate their traffic. Such users might include oil and gas distribution, production, and exploration companies, medical data exchange networks, and emergency warning networks.



## SECTION II

### INTRODUCTION

The basic energy problems facing the United States and the electric utility industry provide motivation to improve system efficiency, shift fuel dependency from limited to more abundant energy sources, reduce reserve requirements for generation and transmission capacity, and improve reliability of service to essential users.

It seems that these motivations will ultimately lead to the appearance of relatively small energy source and storage devices throughout the distribution system. Such devices include fuel cells, solar photovoltaic generation, wind generators, cogeneration units, small hydroelectric units, and are commonly referred to as DSG units. Application of some or all of the concepts generally referred to as distribution automation and load management may also proliferate for a variety of reasons.

As power systems become more complex, as DSG units appear in sufficient size and number to have significant impact on system operations and performance, and as more complex control strategies and distribution automation and load management are used, it seems likely that automated, integrated control systems will come into widespread use.

#### A. OBJECTIVE

This study addresses the communications requirements, principally for monitor and control, that seem to apply to a future electric power utility which has implemented such control into its system and which has integrated a significant number of DSGs. The objective is to produce a preliminary estimate of the projected communications requirements/traffic for future electric utilities. The objective of a separate but related study (see Reference 11) is to assess the appropriateness of a satellite-based communications system (one of many alternatives) to the satisfaction of those requirements.

#### B. APPROACH

The estimation of communications requirements/traffic presented here was developed in several stages that led to the identification of: (1) nodes between which communications links were established, and (2) first-order functional requirements used to define the amount, kind, and frequency of information exchange. Excluded from this estimate are intrasite communication, protective relaying, and normal business telephone traffic.

The identification of communications nodes and links began by modeling a hypothetical utility, as described in Section III. The utility serves about one million customers and derives 5% of its energy from DSGs. An overall control system structure was selected based on considerations outlined in a paper presented at the IEEE PES meeting, February 1981 (see Reference 1). This structure, including top-level functional considerations, is shown in Figure 2-1. From these data, literature (see References 1 through 6), and

consultations with knowledgeable persons, a more detailed functional description has been developed and is described in Section IV. Communications nodes were assigned and data flow diagrams were drawn, as described in Section V. Section VI describes communications traffic that was estimated by function and documented in tabular form. The total traffic between the various communications nodes has been estimated by summarizing the functional traffic. In Section VII, the functional traffic is summarized and examined with respect to various communications technologies.

The estimates referred to in this document are preliminary, speculative, and based on the functional and structural characteristics of a hypothetical utility. Therefore, the estimates are not expected to apply directly to "real" situations. Nevertheless, it is hoped that some of the concepts and techniques presented will prove useful to others. For that reason, and to facilitate future updating, an attempt has been made to document all of the assumptions and factors that were used to develop the results.

The approach used can be applied to other power systems, real or hypothetical, and to other control system structures. Functions can be added, revised, or deleted. Thus, this report provides: (1) an example of possible traffic for an assumed system, and (2) an approach that can be applied to other systems, control configurations, or DSG penetrations.

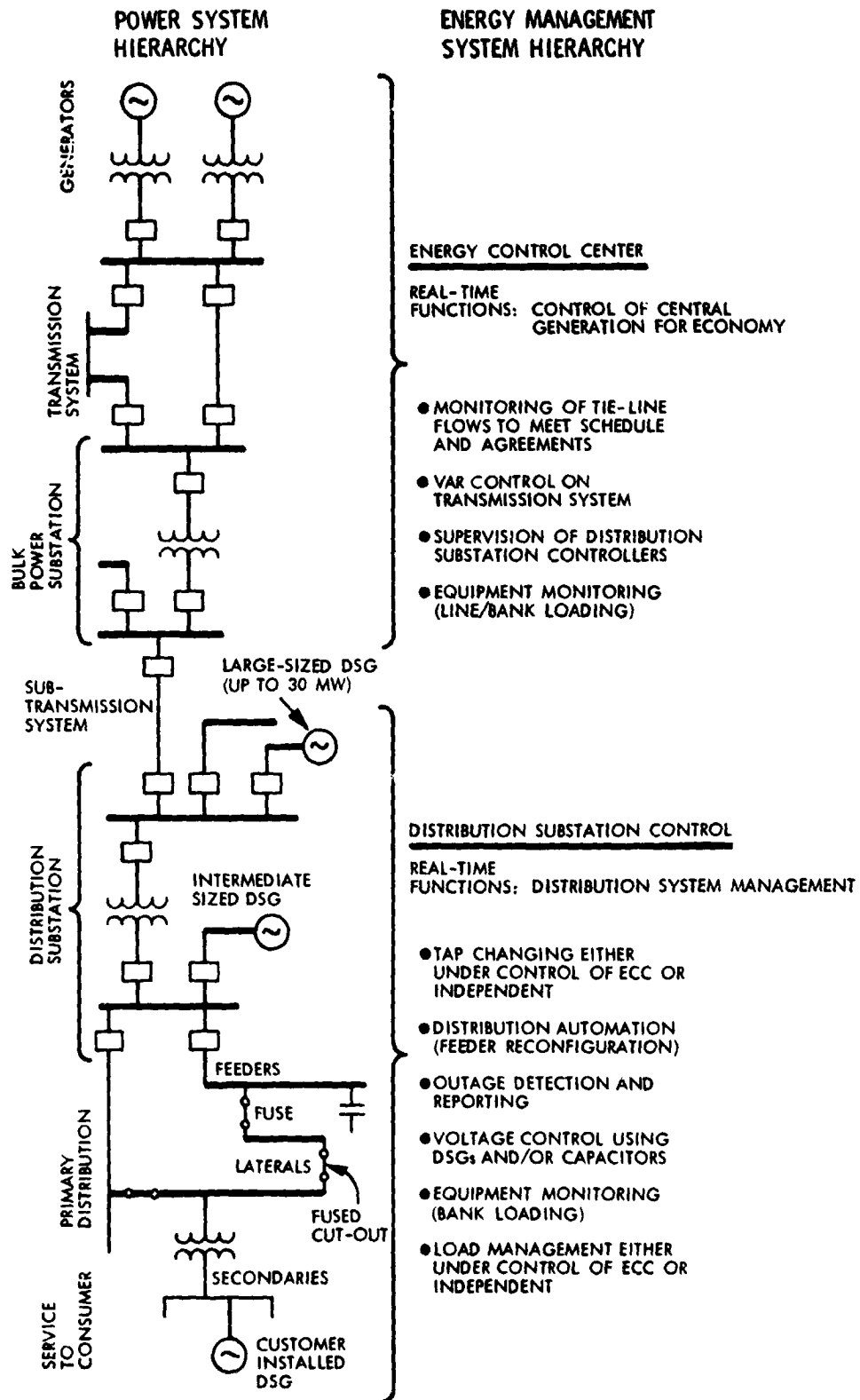

Figure 2-1. Simplified Power System Showing Parallel with Energy Management System Hierarchy

## SECTION III

### DESCRIPTION OF THE SYNTHETIC UTILITY

A synthetic utility was constructed to provide a basis for estimating communications requirements. To this end, details defining points from/to which data must flow (nodes) have been supplied down to the distribution substation primary feeder breaker level. The number of end-use customers has been specified (about one million) and an array of DSGs postulated. Details of the distribution system between the distribution substation and the customer are beyond the scope of this report. Communications requirements for that portion of the system were estimated by methods using average remote device populations similar to those described in References 6 and 10.

#### A. OVERALL CHARACTERISTICS

Many of the features of the synthetic utility used in this study were derived from Scenario A of Reference 7, "Synthetic Electric Utility Systems for Evaluating Advanced Technologies." These systems are regional; they contain about 50,000 MW of generating capacity each, and were intended primarily for studies at the bulk-power level. A fairly high level of detail is provided for the generation-transmission network, a small portion of which is shown in Figure 3-1. Considerably less information is provided for subtransmission, and even less than that for distribution. The details provided at these lower levels are contained in what is referred to as a "plug-in module." This module is shown in Figures 3-2 through 3-5; Figure 3-2 connects to 5 identified buses in each of the major scenarios. Figure 3-3 shows the 138-kV portion of Figure 3-2; Figure 3-4 connects to Figure 3-3 at the 5 138-kV buses 632, 633, 634, 646, and 656. Figure 3-5 contains all the detail presented for the distribution portion of the system, and connects to Figure 3-4 at buses 608, 619, and 623. A total load of 6540 MW is specified for this module, and it also contains 500 MW of generation.

With the above information in hand, the synthetic utility used throughout this study was developed by first slicing out a section of the generation-transmission network of Scenario A. The section chosen was intended to contain a representative generating complex for a mostly metropolitan utility serving about one million customers, and to also contain the 5 buses, 501 through 505, to which the plug-in module of subtransmission attaches. The boundaries of this utility are shown in Figure 3-1. Five generating sites labeled A through E are included at the transmission network; Plant F appears in the module. Also included at the transmission level are: 1 switching station; 1 bulk power substation; and 15 ties to adjacent utilities. Additional details needed to complete the utility description required for purposes of this study were then estimated by averaging, ratioing or by drawing from known data on various real-life utilities.

The diagram of Figure 3-1 includes loads in addition to those represented by the plug-in module. It was estimated by ratioing that these loads sum to 1545 MW, giving a total peak load of 8085 MW. As the base generation capacity is 11,550 MW, and the DSG contribution, as explained later, is 580 MW, the total available load is 12,130 MW. Therefore, the peak load fraction is 67%,

**SYNTHETIC UTILITY BOUNDARY**

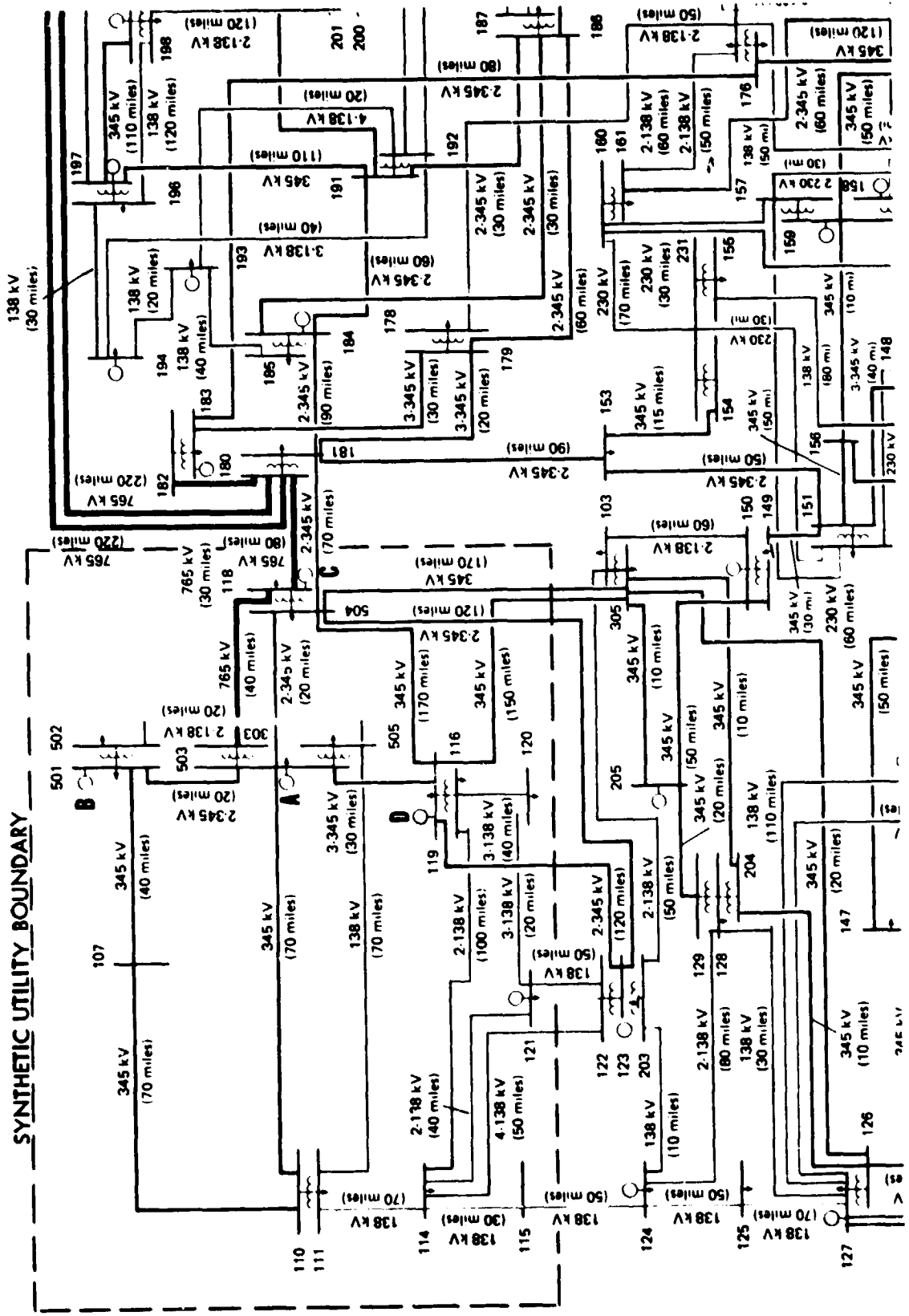

**Figure 3-1. Synthetic Utility Transmission System**

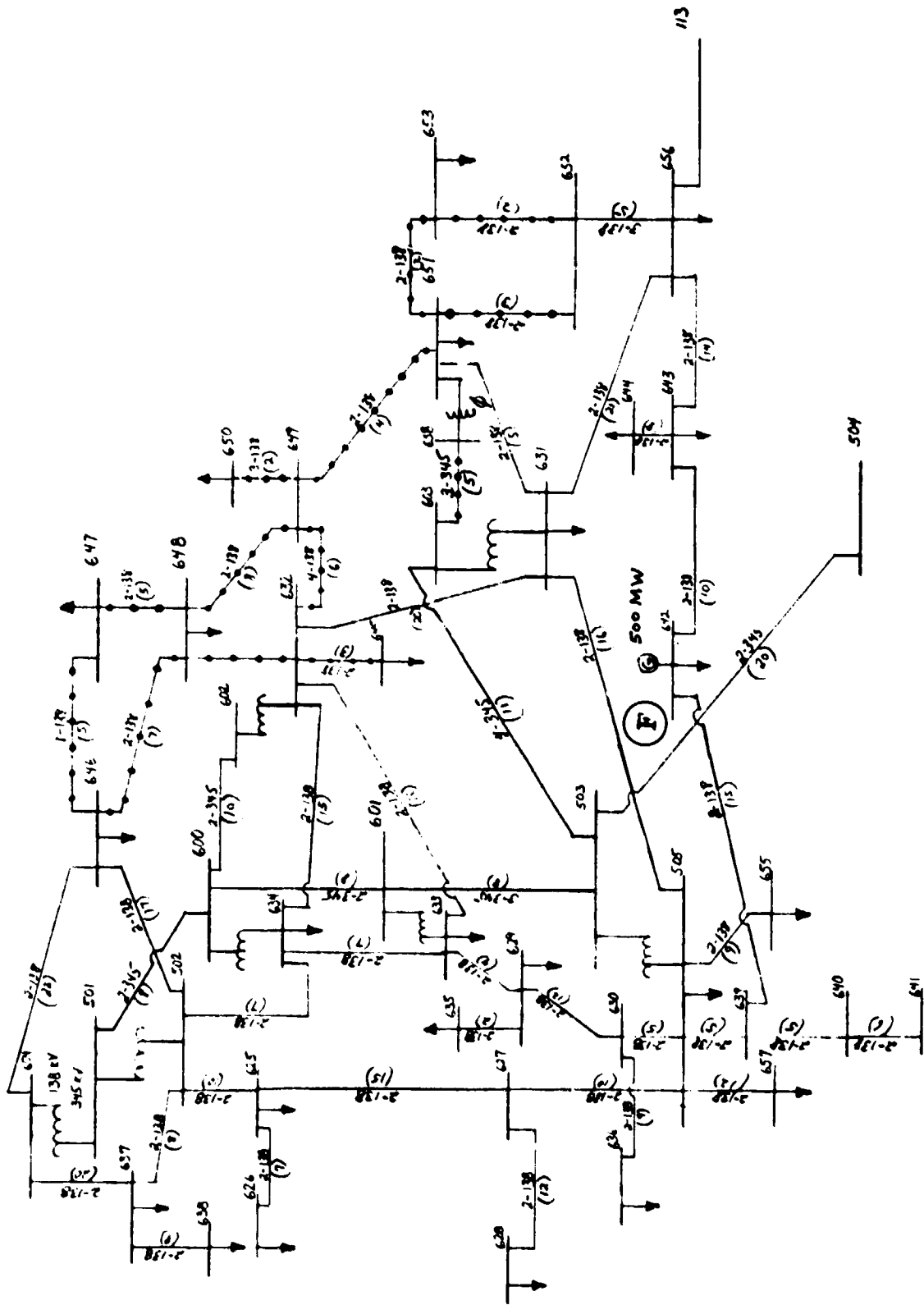

Figure 3-2. 345/138-kV Subtransmission System

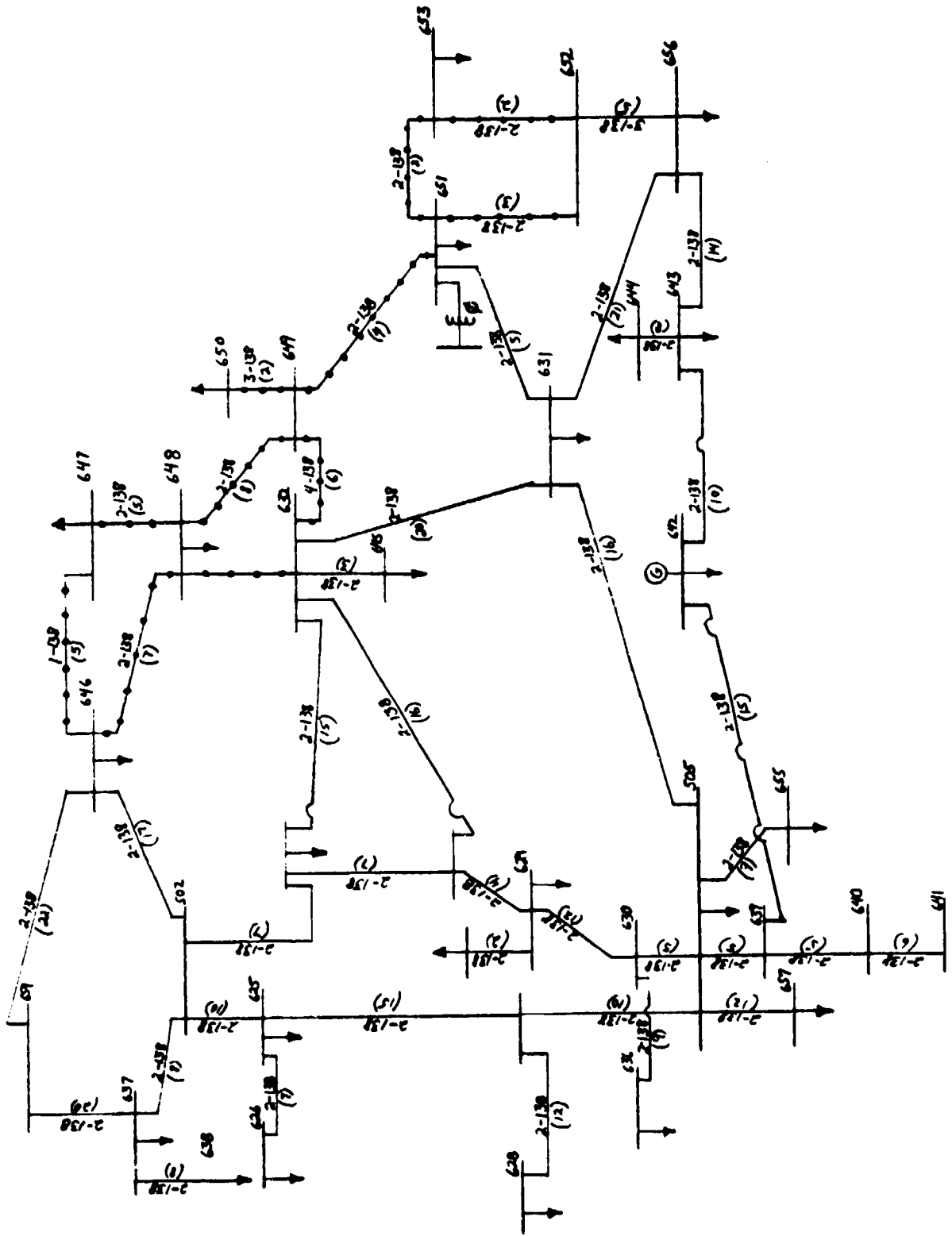

Figure 3-3. 138-kV Subtransmission System

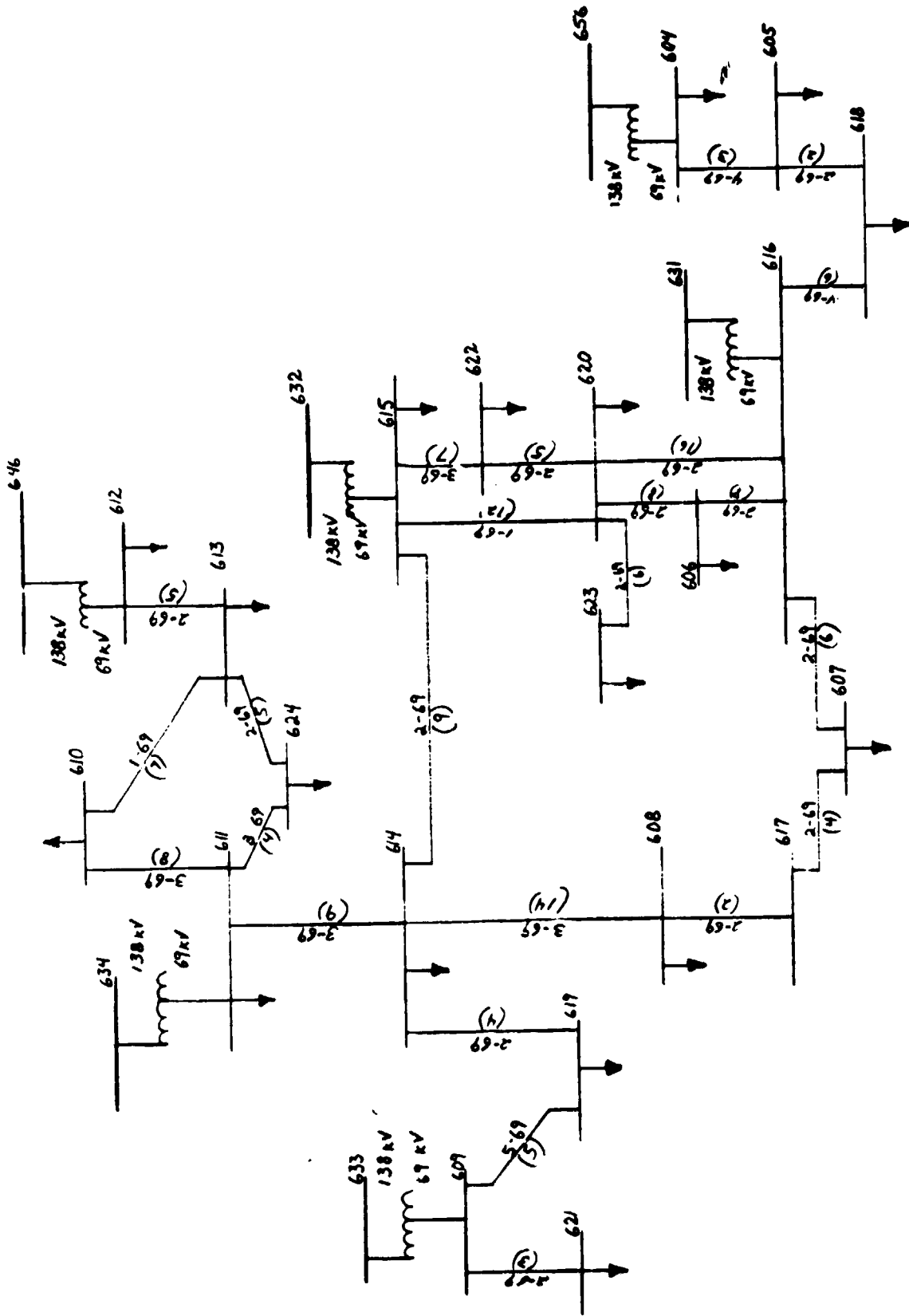

Figure 3-4. 69-kV Subtransmission System



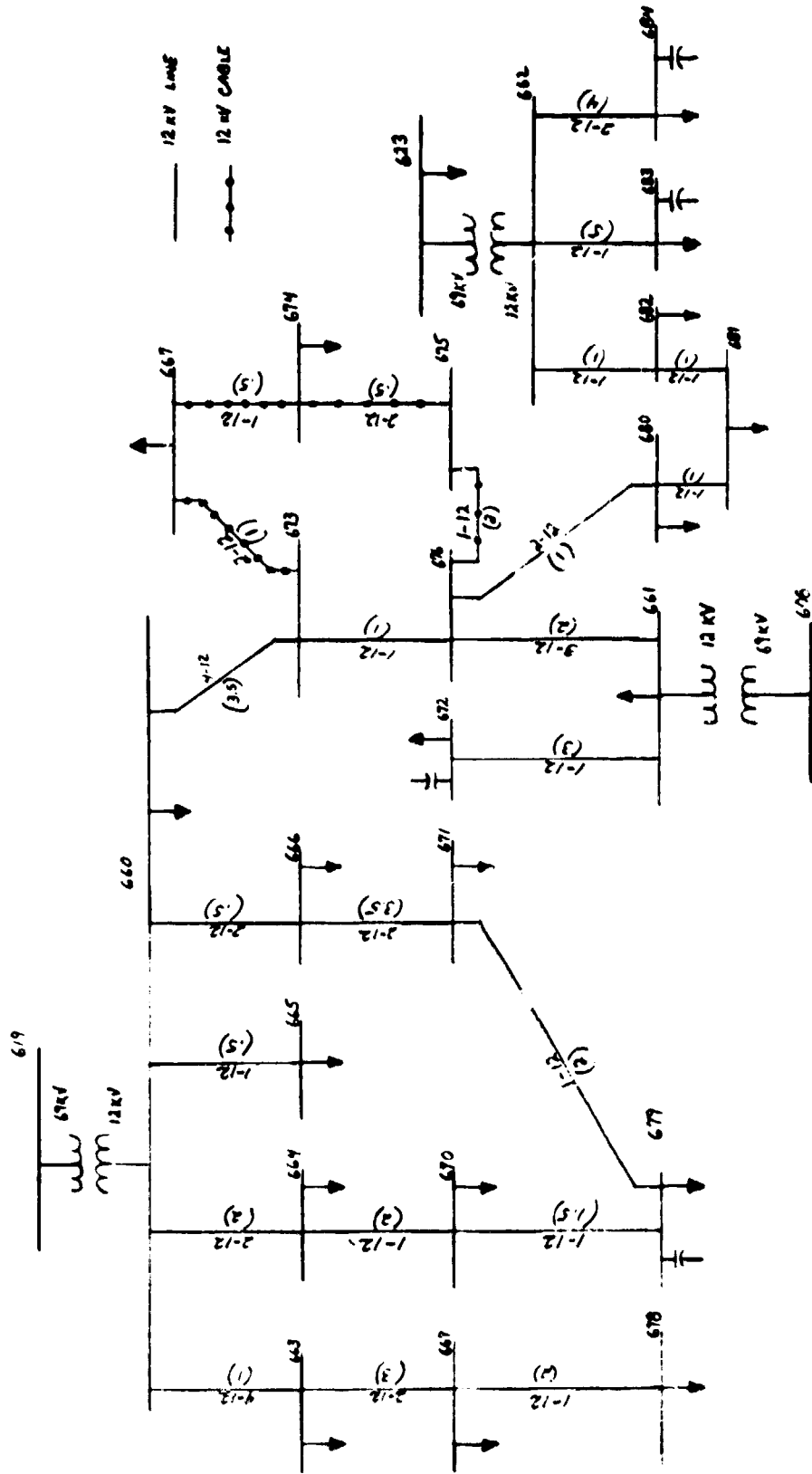

Figure 3-5. 12-kV Distribution System

and the margin is 4045 MW, which just equals the rating of the nuclear units at Plant D. Table 3-1 summarizes key features of the generation facilities given by Reference 7. Since the total generation capacity seems somewhat high, it was assumed that Plant D, the nuclear portion in particular, is jointly owned with a neighboring utility.

Figures 3-2 through 3-5 present subtransmission and distribution plug-in module details as presented in Reference 7. The location of Powerplant F is shown in Figure 3-2. In developing additional details of the utility, it was assumed that each load arrow in Figures 3-2 and 3-3 represents a bulk power substation, and that each multilines bus without a load arrow or transformer represents a switching station.

Table 3-1. Model Utility Generation Plant Description

Plant	Bus	Voltage, kV	Unit Description	Plant Capacity, MW
A	503	345	9 at 50 MW-CT	450
B	501	345	2 at 1200 MW-N, 4 at 50 MW-CT	2,600
C	118	765	5 at 200 MW-CT	1,000
D	119	345	4 at 1000 MW-N, 5 at 400 MW-O, 5 at 50 MW-CT	6,250
E	121	138	2 at 200 MW-C, 7 at 50 MW-CT	750
F	642	138	(4 at 125 MW-H) <sup>a</sup>	<u>500</u>
Total				11,550

CT = Combustion Turbine = 11%  
 N = Nuclear = 56%  
 O = Oil = 26%  
 C = Coal = 3%  
 H = Hydro = 4%

<sup>a</sup>Assumed for this study.

Three distribution substations are explicitly shown in Figure 3-5 and it was assumed that the remainder of the load arrows in Figure 3-4 also represent substations, giving a substation-to-bus ratio that can be carried back to Figure 3-3. This approach leads to an estimate of about 70 substations for this largely metropolitan utility, which was felt to be too few to be representative. Therefore, a total of 200 distribution substations was specified for the entire synthetic utility, which yields a more representative average of 5000 meters per substation.

Table 3-2 summarizes the major characteristics of the synthetic utility. Also shown in the table are a complex of DSGs. Small units are connected to distribution feeders, intermediate units to the distribution substation secondary buses, and the larger units to the substation primary buses.

The derivation of this DSG set is shown in Table 3-3. Estimates of the contribution DSG will make to the national installed generating capacity, by the year 2000, have ranged from 4 to 10%. For this study, 5% of the base generation capacity was selected. It was estimated that one-quarter of all feeders would have two to ten small units connected, averaging 75 kW each, for a total capacity of 136 MW. The remaining capacity was then divided equally between intermediate and large DSG units. Very small household class units were excluded from this study because any form of direct control by the utility seemed unlikely.

Table 3-2. Synthetic Utility Major Characteristics

Item	6540-MW Load Module	Estimated 1545-MW Additional Load	System Total
Generating Plants	--	--	6
Bulk Supply Substations	28	7	35
Industrial Substations	--	--	40
Switching Stations	5	1	6
Intertie Lines	--	--	15
Distribution Substations	--	--	200
Meters			$1.0 \times 10^6$
DSG Sites: Large			11
Intermediate			44
Small			1800

Table 3-3. Dispersed Storage Generation Derivation

	Megawatts	Units
Total Base Generation	11,550	--
DSG Fraction (5%)	580	--
Small DSG (Photovoltaic, Wind, Batteries, Fuel Cell, etc.)		
(1) 1200 feeders x 1/4 x 6 $\frac{\text{units}}{\text{feeder}}$ : units		1800
(2) $\frac{75 \text{ kW}}{\text{unit}}$ average: capacity	136	
Intermediate DSG (Battery, Fuel Cell, Low-Head Hydro)		
(1) $\frac{580 \text{ MW} - 135 \text{ MW}}{2}$ : capacity	222	
(2) $\frac{5 \text{ MW}}{\text{unit}}$ average: units		44
Large DSG (Hydro, Cogeneration)		
(1) $\frac{580 \text{ MW} - 135 \text{ MW}}{2}$ : capacity	222	
(2) $\frac{20 \text{ MW}}{\text{unit}}$ average: units		11

**B. ONE-LINE DIAGRAMS**

To assist in estimating the communications requirements for various point-to-point links, several one-line diagrams were generated based on the information contained in Figures 3-1 through 3-5. Worst-case, or highest data-point-count, examples were chosen in each case. The assumed arrangement of Generation Plant D is shown in Figure 3-6. It is further assumed that the nuclear, oil, and combustion turbine units are housed in separate generation facilities, each with its own local controller and RTU.

Table 3-4 lists some details for the bulk supply substations which are explicitly shown in Figures 3-1 and 3-2. Other load arrows of Figure 3-2 seem to be additional substations. From these data, Substation C was selected for diagramming; and its details are shown in Figure 3-7.

Finally, from Figure 3-5, the distribution substation whose secondary bus is 660 was chosen. It is apparently a combination switching and distribution substation. The diagram for this station is shown in Figure 3-8. One RTU is installed at each bulk power and distribution substation, and a standard message

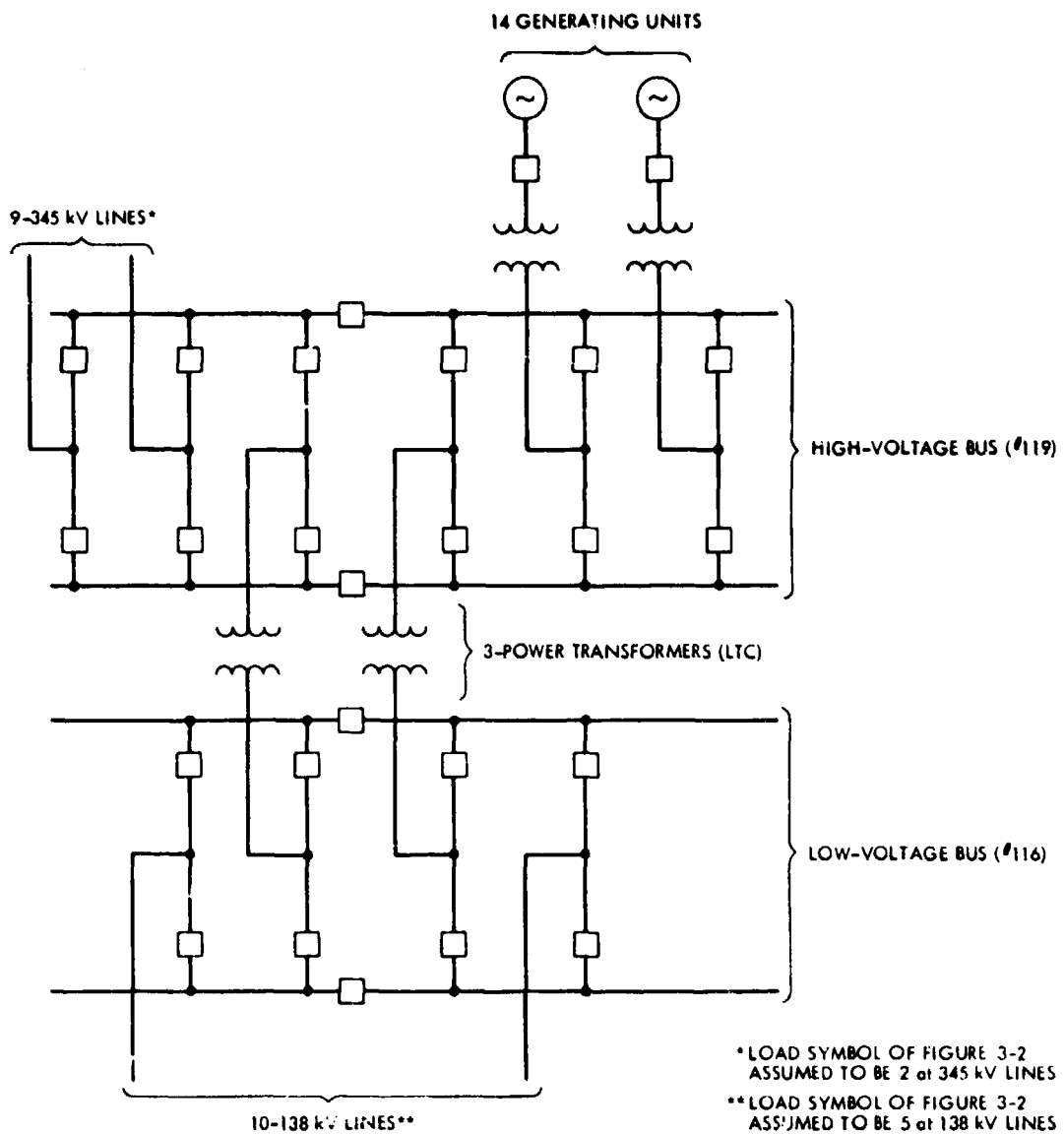

Figure 3-6. Generation Plant D One-Line Diagram

Table 3-4. Bulk Supply Substation Data

Substation	High Side			Intermediate Side			Low Side			Additional Load		
	Bus	kV	Lines	Bus	kV	Lines	Bus	kV	Lines	High	Intermediate	Low
a	110	345	2	--	--	--	111	138	2	--	--	Yes
b	658	345	3	--	--	--	651	138	8	--	--	Yes
c	603	345	7	631	138	8	614	69	10	--	--	--
d	601	345	5	633	138	6	609	69	7	--	--	--
e	600	345	6	634	138	6	611	69	9	--	--	Yes
f	602	345	2	--	--	--	632	138	14	--	--	--
g	501	345	2	--	--	--	502	138	8	--	--	--
h	646	138	7	--	--	--	654 612	138 69	4 2	--	--	Yes
i	656	138	7+	--	--	--	604	69	4	--	--	Yes

Additional 345/138-kV loads (substations) not detailed = 19.

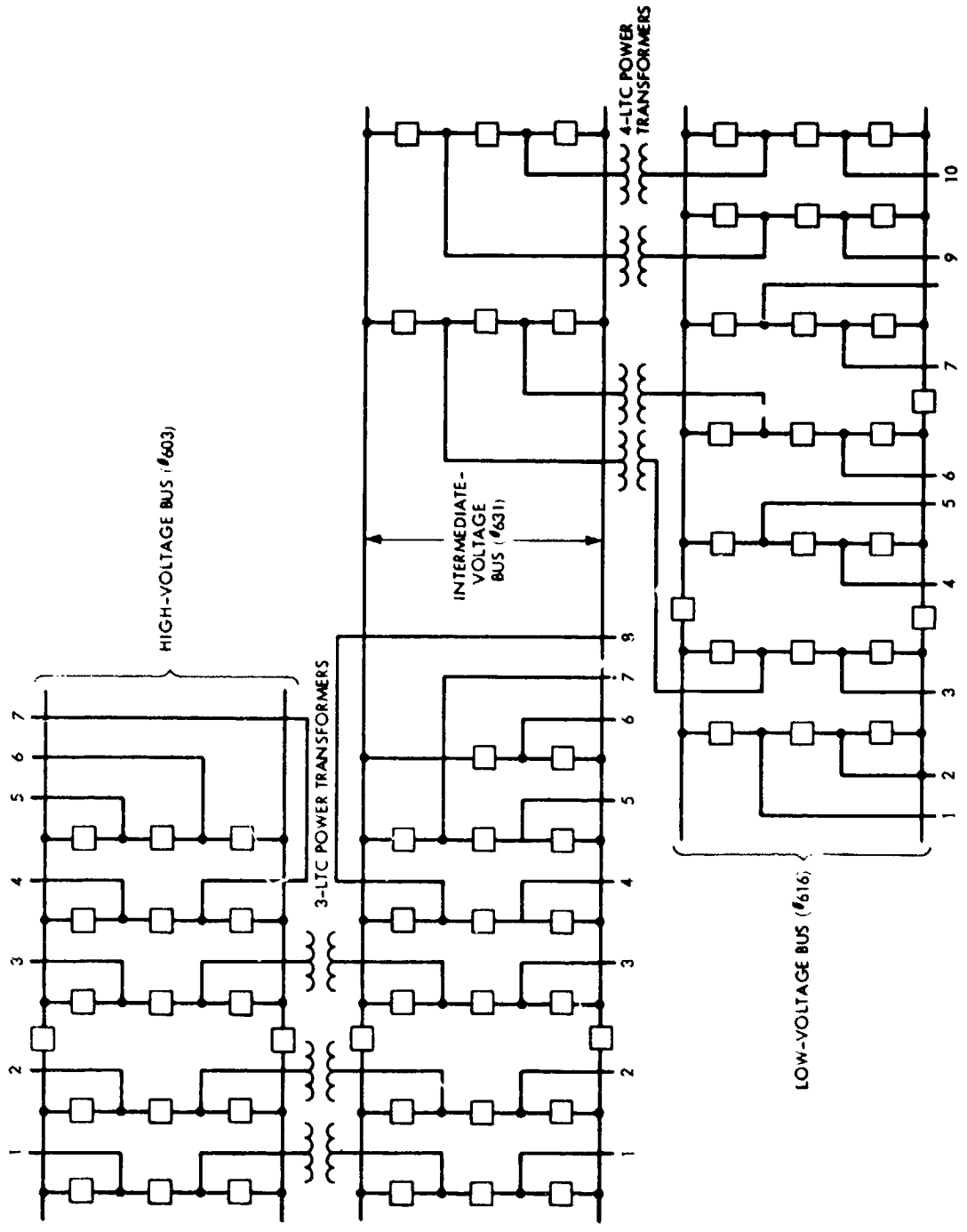

Figure 3-7. Bulk Power Substation C One-Line Diagram

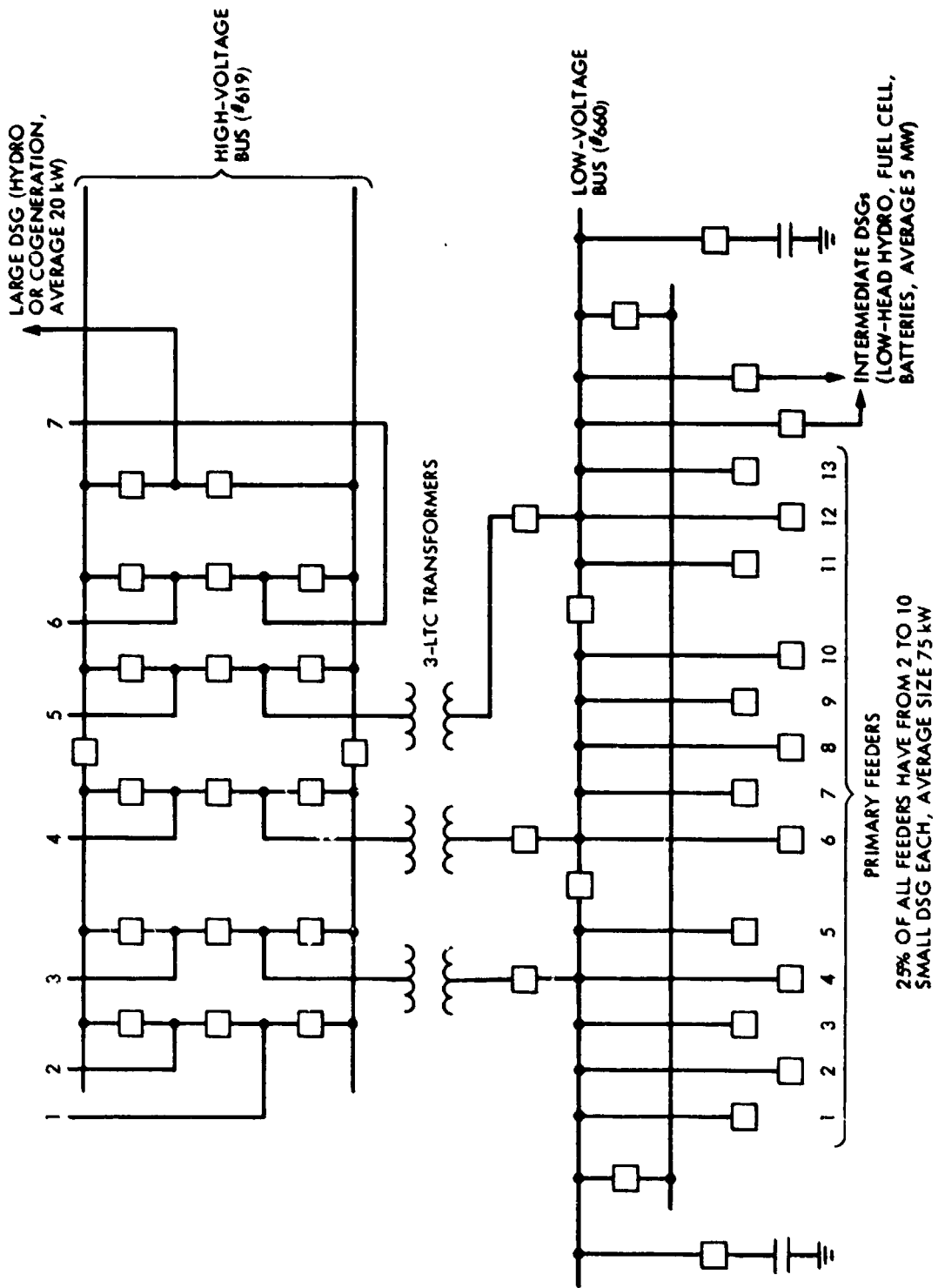

Figure 3-8. Distribution Substation One-Line Diagram



protocol has been assumed. These high-data-point count installations were then analyzed in a later section to determine the number of standard messages necessary to collect the functionally required information.

### C. DISTRIBUTION SYSTEM MODEL

In actual practice, distribution systems are highly complex and diverse. Schematic representation of such a real system is beyond the scope of this study. However, an estimate of the number of points requiring communication is necessary to the overall traffic estimate. Therefore, some average relationships were selected which are thought to be representative and have been used to quantify communications nodes. These relationships are:

- (1) 6 feeders per distribution substation.
- (2) 1 remote capacitor bank per feeder.
- (3) 1 remote voltage regulator and voltage sensor per feeder.
- (4) 4 remote operated switches per feeder.
- (5) 1 remote MW and MVAR sensor per feeder.

When these relationships are applied to the previous estimated 200 distribution substations, the following system-total equipment count and communications node count is obtained:

- (1) 200 distribution substations.
- (2) 1200 primary feeders.
- (3) 1200 remote capacitor banks.
- (4) 1200 remote voltage regulators and sensors.
- (5) 4800 remote operated switches.
- (6) 1200 remote MW and MVAR sensors.

## SECTION IV

### FUNCTIONAL ANALYSIS

In recent years there have been, in literature, studies that present functional requirements for various aspects of control on the distribution system. From these studies, communications requirements were derived in one form or another (see References 2 through 6). No similar analysis was found of functional requirements and performance parameters for a complete utility or an overall Energy Management System (EMS).

The purpose of a communications network is to facilitate the transfer of information to satisfy the functional needs of the various elements of a utility. Therefore, a set of overall functional requirements and objectives has been assumed as a first step in establishing these communications requirements. From these requirements, EMS requirements have then been derived. An attempt was made to be comprehensive; however, they are presented primarily to form the basis upon which the communications requirements were developed.

#### A. THE SYNTHETIC UTILITY

The objectives and functional requirements, with principal interfaces and information flows, are shown in Figure 4-1. The focus is on those functions that seemed most significant regarding communications impact. For some of these functions, the implications may not be immediately obvious. For example, improving reliability to essential loads is one of the principal drives for extensive distribution automation; thus, the improvement will impact communications. Providing capacity to meet future needs implies load research to project those future needs. The use of abundant energy resources establishes motivation for DSGs. Maintenance of satisfactory service impacts many activities such as load management, load shedding, fault isolation and recovery, and DSG monitoring and control. These functions, objectives, and interface definitions provide the foundation for the development of more detailed requirements.

#### B. THE ENERGY MANAGEMENT SYSTEM

The relationship between the power system and the several elements of the Energy Management System (EMS) are shown in Figure 1-1. For the concept of EMS used in this document, each bulk power system generating unit/station, and each DSG, has its own local controller. The local controller is responsible for detailed operation of the generation or storage unit. However, the unit receives and responds to high-level control instructions from the EMS which establishes its mode and output: it transmits to the EMS critical monitor data, alarms, and appropriate meter readings.

Figure 4-2 depicts the functions and interfaces for the ECC. These functions permit definition of the data collection needs of the EMS; however, for some of them the implications are not obvious.

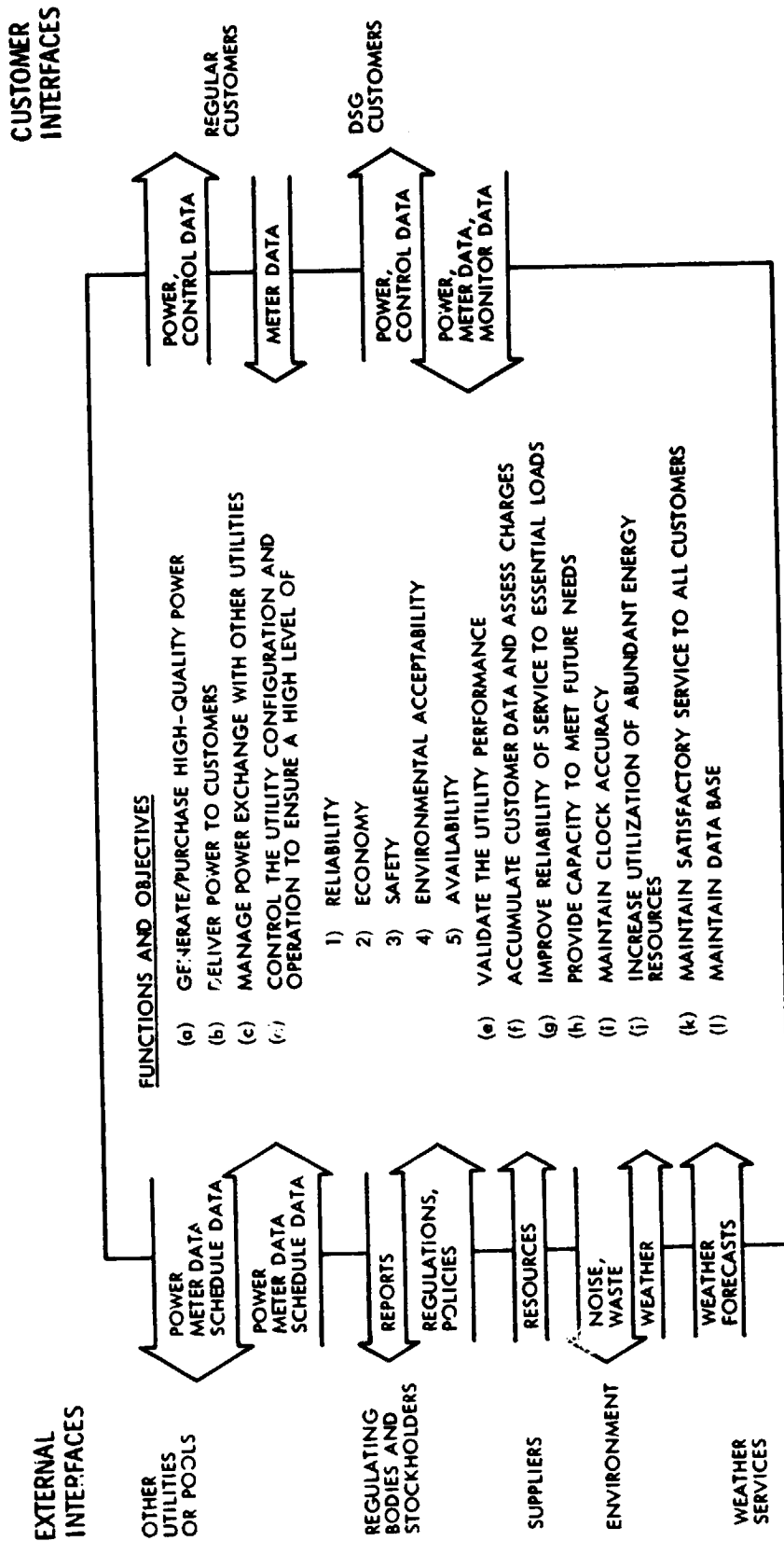

Figure 4-1. Functions and Interfaces of Model Electric Utility

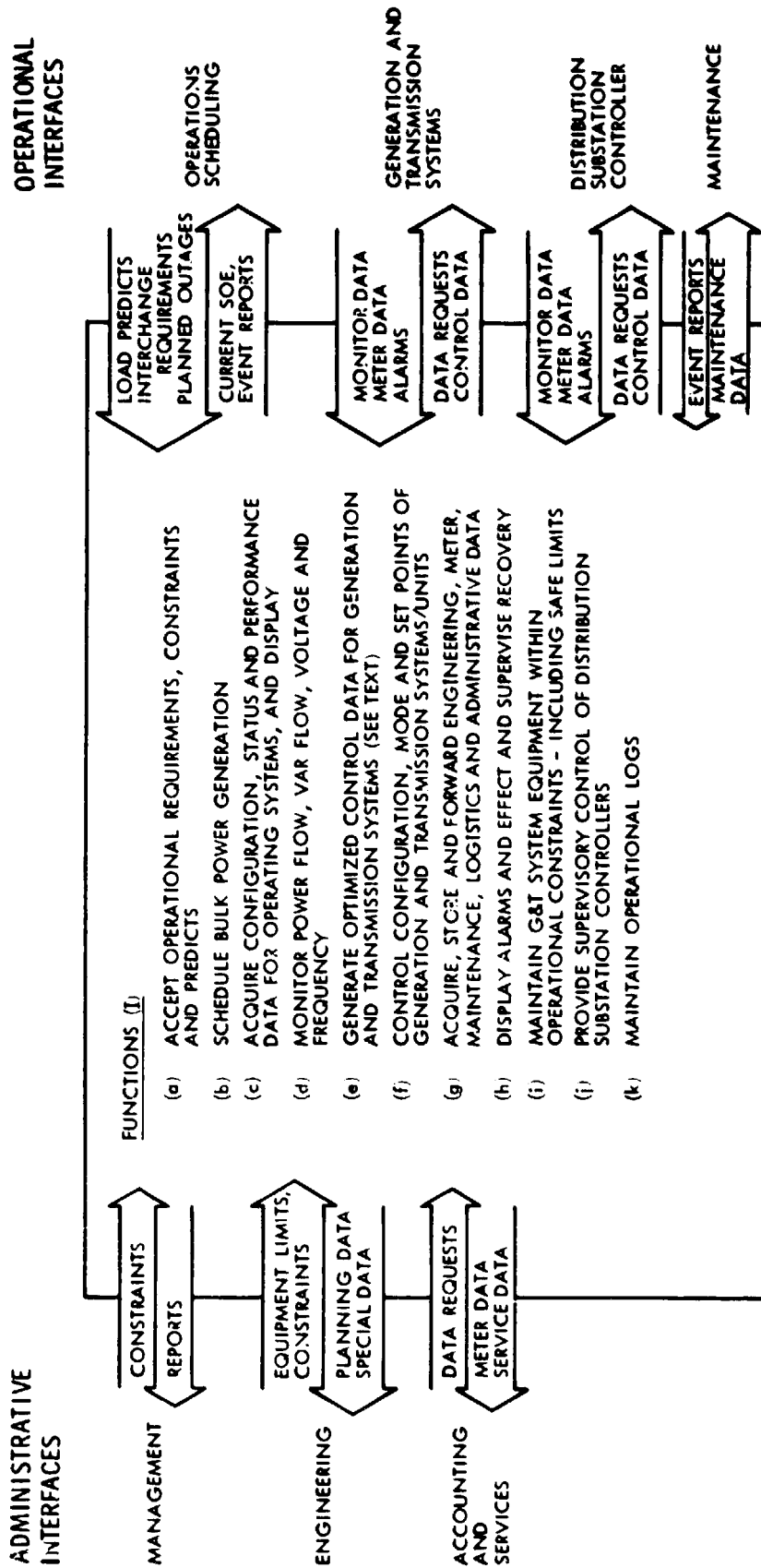

Figure 4-2. Functions and Interfaces for the Energy Control Center

Optimized control data require that the information support at least the following functions or considerations:

- (1) Automatic generation control.
- (2) Economic dispatch.
- (3) Minimum emission dispatch.
- (4) Generation capability calculations.
- (5) Spinning reserve requirements and actuals.
- (6) Optimum hydro-thermal generation coordination.
- (7) Energy storage scheduling.
- (8) Interchange evaluation, cost quotation, prescheduling.
- (9) Line, bus, and transformer load management.
- (10) Resource availability.
- (11) Fault impact minimizing.
- (12) System security analysis.
- (13) State estimation.
- (14) Voltage, VAR, and frequency control.
- (15) On-line load flow.

Separate measurements are not required to support each of these functions. A basic set of necessary measurements has been derived and is shown in Table 4-1.

Functions and interfaces for the DSSC are shown in Figure 4-3. Optimized control of the distribution system requires a different set of considerations and measurements. Some of these considerations are:

- (1) Feeder load management.
- (2) Cold-load pickup control.
- (3) Voltage regulation.
- (4) Transformer load management.
- (5) Load reconfiguration.
- (6) Customer load management.

Table 4-1. Data Collection Requirements for the Operating Systems:

Generation	Transmission	Distribution
Gross and net MWh and 3 $\phi$ MW and MVAR of each generating unit	3 $\phi$ MW and MVAR flow, frequency and MWh on each end of each tie-line, 345 kv and above	3 $\phi$ MW, MVAR, secondary voltages, and LTC tap positions and temperatures for each DSS transformer bank
On/off status of each generating unit and AGC controller	MWh for each bulk power substation transformer bank	Status of each substation circuit breaker
MW output limits and MW/min rate of change, limit of each unit	3 $\phi$ MW and MVAR flow, each end of each line, 345 kv and above	1 $\phi$ MW and MVAR flow each primary feeder
NO <sub>x</sub> , SO <sub>x</sub> and CO output of each thermal unit	1 $\phi$ MW and MVAR flow, each end of each line, 138 kv and below	3 $\phi$ line side voltage each shunt capacitor
Thermal unit fuel consumption and heating value	Hot-line indication each line and bus	Discretionary load switch on/off status
Switchyard frequency and status each circuit breaker	1 $\phi$ voltage, each bus	Customer meter register status: peak mid, off-peak
Transformer temperatures and tap change position	3 $\phi$ MW and MVAR plus tap change position and temperature: each transformer	Load reconfiguration circuit breaker status
Bus voltages, single phase	3 $\phi$ line side voltage each series capacitor	Voltage at dispersed voltage regulators, regulator status
Water flow, pond level, fuel level, storage tank temperature, and status	Status of each circuit breaker	Fault detection sensor status
Alarms	Weather data from selected BPS registers	Customer meter readings, three
	Alarms	Alarms

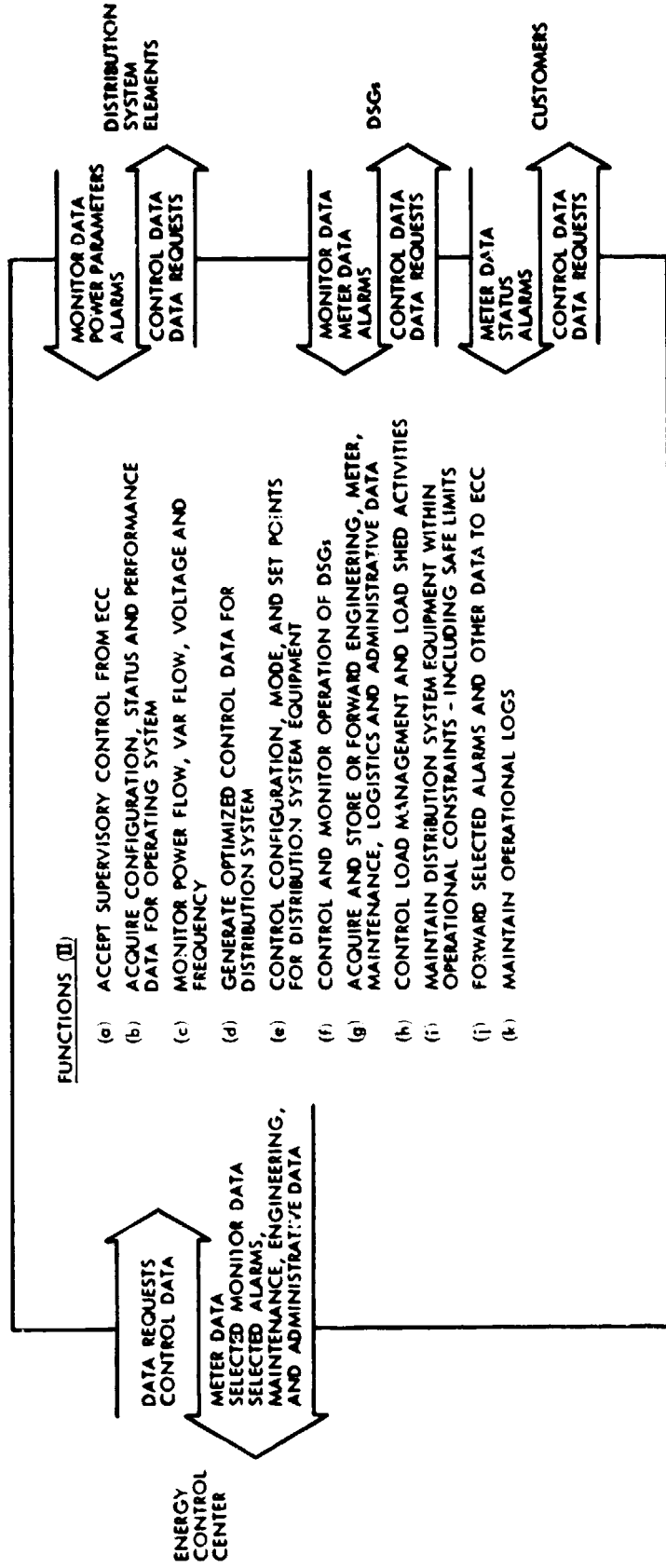

Figure 4-3. Functions and Interfaces for the Distribution Substation Controller

(7) Emergency load shedding strategy.

(8) Meter reading.

The measurements required to support the DSSC functions are also shown in Table 4-1.

In estimating the communications traffic, it is necessary to know how much information will be exchanged and how often. A general plan for regular collection of data in support of the real-time operational functions is shown in Table 4-2. Although these rates were selected somewhat arbitrarily, it is believed that they represent current practice within the industry. In any event, other rates can be substituted, and the resultant effect on the traffic analysis described in Section VII can be calculated.

Table 4-2. Polling Rates for Data Acquisition

Function	Polling Interval
(1) Bulk power system analogs for AGC (tie flows, generation, and frequency)	2 s
(2) Bulk power system breaker and device status	2 s
(3) High-priority alarms and indications	2 s
(4) Bulk power system internal flows and voltages	10 s
(5) Subtransmission system breaker and device status	10 s
(6) Subtransmission system flows and voltages	30 s
(7) Noncritical system data (weather, transformer temperatures, etc.)	30 s to 10 min
(8) Low-priority alarms	30 s
(9) Bulk Power Substation power transformer and tie-line energy accumulations	1 h
(10) Distribution substation breaker and device status	10 s
(11) Distribution flows, voltage, remote device status, etc.	30 s
(12) DSG analogs for AGC:	
Intermediate	2 s
Large	2 s



## SECTION V

### COMMUNICATIONS NETWORK

In the previous sections, the physical makeup of a synthetic utility has been described, and the functional needs for communication have been established. The types of measurements that need to be made to support the real-time operation of the utility have been listed and the various intervals at which such data must be gathered have been specified. It now remains to establish the nodes between communications traffic flow, and the characteristics of that traffic.

#### A. DATA-FLOW CHANNELS

The real-time operational data-flow channels for the utility ECC, and most of the other regularly used links are shown in Figure 5-1. The figure also shows the number (N) of RTUs with which communication must occur. These are obtained directly from the physical description of the utility in the case of units related to direct operation of the power system. One RTU has been assumed for each major unit, i.e., substation, large industrial customer, or switching center, with the exception of bulk generation plants. An RTU has been assumed for each class of generation unit, i.e., nuclear, oil, combustion turbine, etc., and one RTU for each switchyard. The major support functions are remotely located from the ECC, and the number of these communications nodes has been assigned somewhat arbitrarily. For those channels through which data are collected on a periodic basis, the interval (s) at which the most critical data are scanned is also shown.

Except for the links between maintenance centers and mobile units, only primary data channels are shown. Backup or alternative channels would be provided to the most critical locations, such as transmission and generation control sites, and probably at least one voice channel to each RTU location for troubleshooting and/or manual operation.

The data-flow channels for a typical (average) substation are shown in Figure 5-2. It was estimated that 60% of the ordinary customers ( $6 \times 10^5$ ) are under a load management program along with an arbitrary number (about  $3 \times 10^4$ ) of commercial customers.

#### B. MESSAGE PROTOCOL

The message protocol used in this study is based on the current working draft of recommended practice for master/remote communication prepared by the IEEE, Automatic and Supervisory Systems Subcommittee of the IEEE Substations Committee (Reference 8). This practice extends and amplifies information contained in ANSI Standard 37.1-1979, Definition, Specification and Analysis of Manual, Automatic and Supervisory Station Control and Data Acquisition (Reference 9). This protocol has not yet been formally recommended; however, it seems at this time to be the most reasonable choice for this study. Changes in this protocol can have significant impact on the traffic, especially when the response message from an RTU contains few data bits.

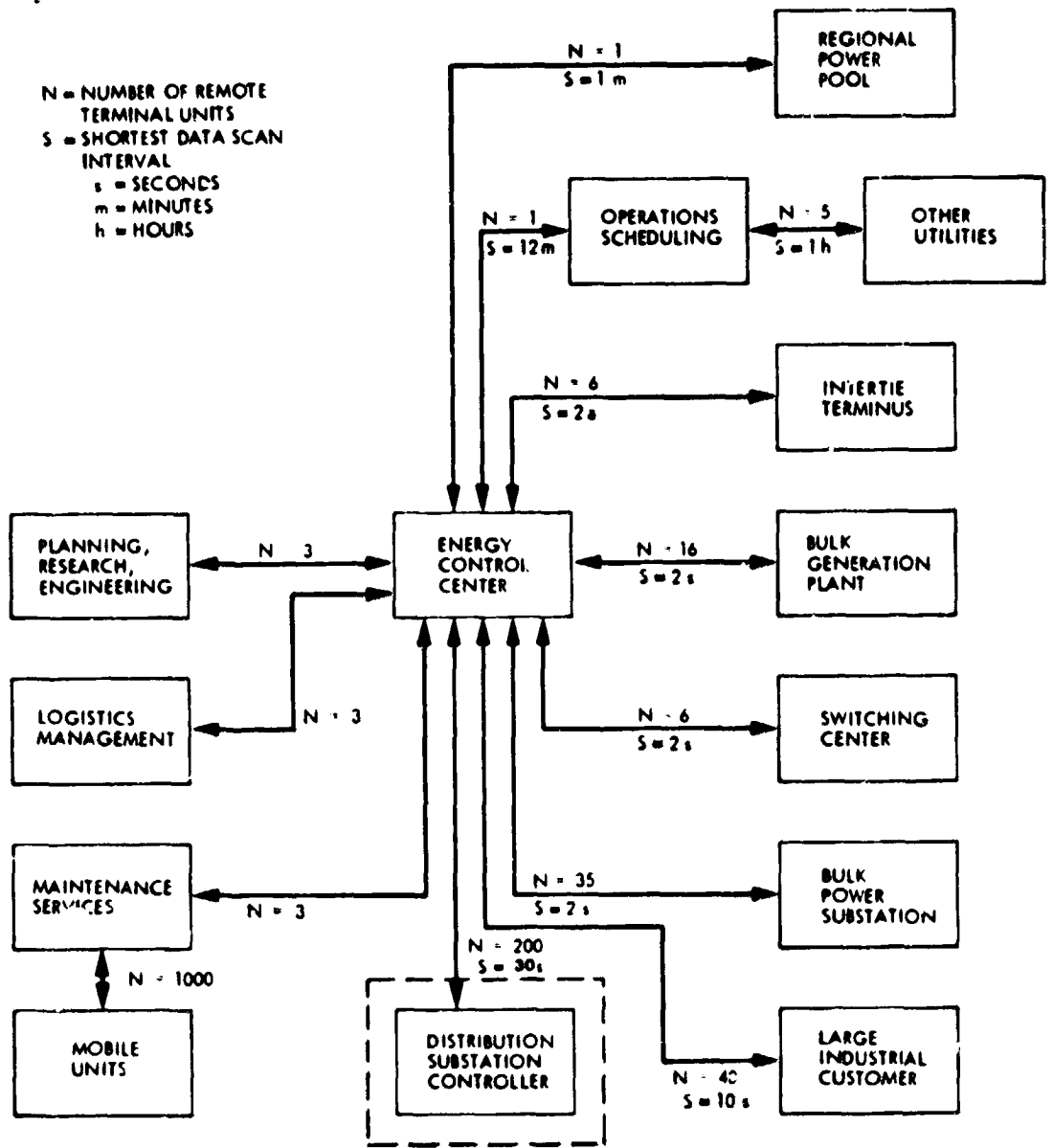

Figure 5-1. Energy Control Center Data-Flow Diagram

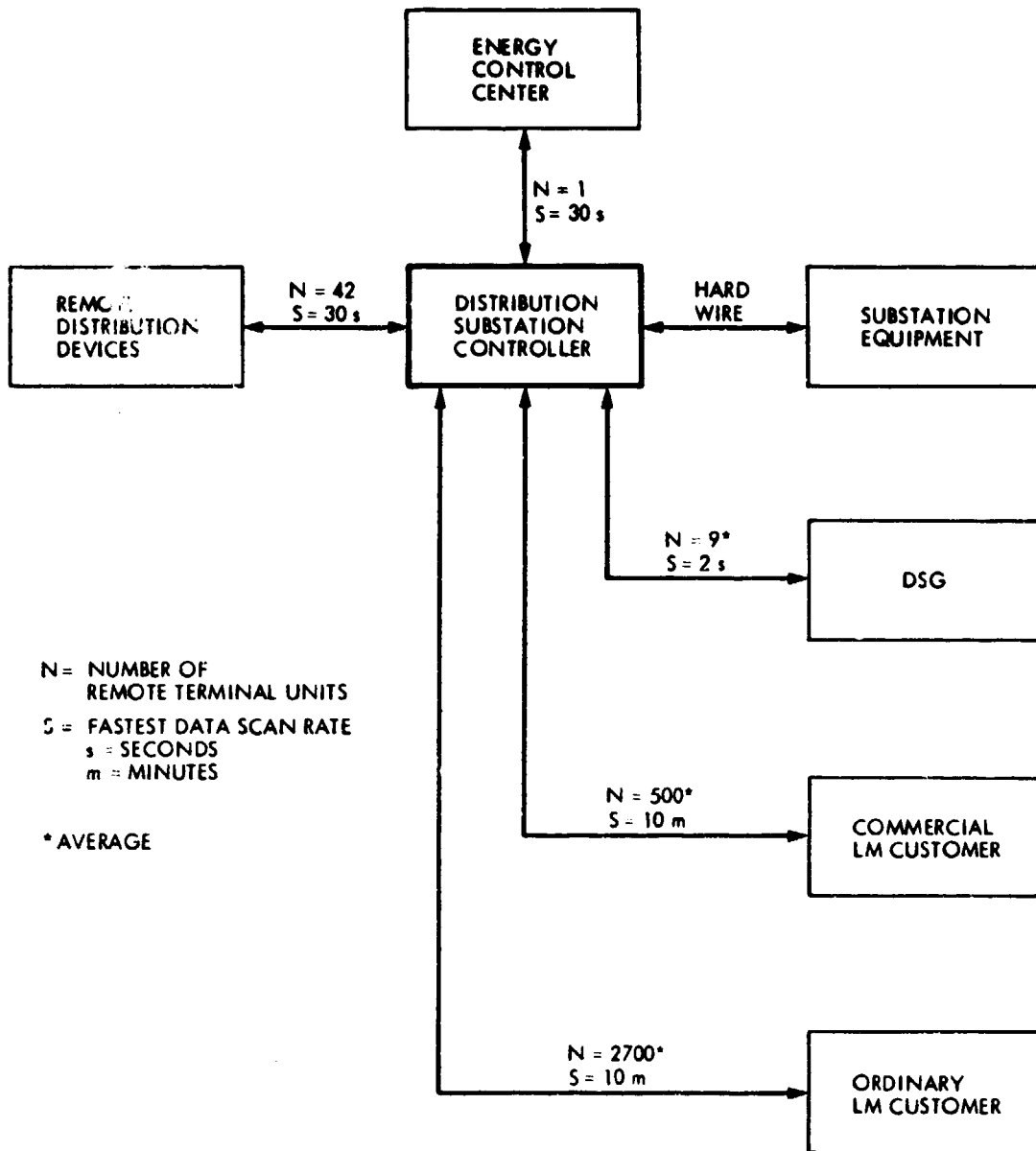

Figure 5-2. Distribution Substation Data-Flow Diagram

All communications are conducted in the poll-and-response mode with the exception of "direct operate" commanding, in which no response is required. The standard format for messages and the currently specified message types are shown in Tables 5-1a and 5-1b (see Reference 8).

Table 5-1b shows that normal periodic data collection will be accomplished using remote-to-master response messages containing 8 to 192 sensed data bits (1 to 24 bytes). Table 5-2 shows how these data are used. Standard messages can, of course, be formatted using combinations of these data types.

The working paper specified that all operations be in the half-duplex mode, which seems somewhat restrictive when considering technologies such as a communications satellite or coaxial cable. The message space required for a transaction under this condition can be found in Table 5-1b. The poll message would consist of the preamble period, 50 overhead bit periods, and 24 data bit periods. The response message would also consist of the preamble and 50 overhead bits plus 32 to 216 data-bit periods. If one allows 100-bit periods for preamble, a reasonable allocation for a high-speed channel, the ratio of desired information to total message transaction bits will vary from 56/356 (16%) to 240/540 (44%).

On the other hand, operating in the full-duplex mode, and allowing a full preamble for each response message, results in efficiencies range from 18 to 59%. If a series of messages is to be sent from one RTU, even higher efficiencies can be achieved if carrier lock and bit synchronization can be maintained through out the series.

In the study, the half-duplex mode has been used throughout; therefore, a poll message is required for each response message, either type 5 or type 6. A poll message consists of 174 bits and a response message of from 174 to 366 bits in increments of whole bytes (8 bits).

Table 5-1a. Message Format Summary: Standard

Establishment		Information		Termination		
Preamble <sup>a</sup>	Message Sync	Address	Data	Status/Command	Error Code	End
Variable	1 Byte	1 Byte	3-27 8-Bit Bytes	2 Bytes	2 Bytes	2 Bits

<sup>a</sup>Used for carrier acquisition (if needed) and bit sync.

Table 5-1b. Message Types

Type	Transaction Type	Total Bits/Message <sup>b</sup>	
		Master-Remote	Remote-Master
1	Command, Direct Operate	74	0
2	Command, Control	74	74
3	Select-Before-Operate Control	74	74
		<u>74</u>	<u>74</u>
		148	148
4	Batch Data Transfer	74	74
		<u>266</u>	<u>74</u>
		340	148
5	Data Request	74	82 - 266 <sup>c</sup>
6	Report by Exception	74	266 <sup>c</sup>

<sup>b</sup>Not including preamble.

<sup>c</sup>3 bytes reserved for function, point address and RTU data; therefore, 24 bytes are available for sensed data.

**Table 5-2. Application of Remote-to-Master-Response Messages**

---

Data Type	Bit Allocation	24-Byte Message Contents
Analog	12 (including sign)	16
Control and Indication	8 (including sign and status)	24
Indication	1	192
Megawatt hours	24 (6 decimal digits)	8

---

## SECTION VI

### COMMUNICATIONS REQUIREMENTS

A synthetic utility of about one million customers has been constructed, as described in this report. Functional requirements affecting communications needs have been developed, and a control hierarchy and communications network have been postulated. In this section, specific communications requirements between the various network nodes will be developed. Those dealing with data needed to support on-line operations will be addressed first because they can now be described explicitly. Estimates will then be made of the administrative/service communications.

#### A. ON-LINE OPERATIONAL REQUIREMENTS: BULK POWER SYSTEM

In the normal operating mode, the ECC will request monitor data, at appropriate regular intervals, from the various remote terminals. Analysis of these data may result in a desired action, and a command will be issued. However, most of the traffic will result from data collection rather than from control commanding activities.

Table 6-1 relates the functional requirements of Section IV and the message protocol of Section V to develop specific scanning requirements for the bulk power generation system. Tables 6-2a and 6-2b apply these scan requirements to develop telemetry lists for Generation Plant D of the synthetic utility in the form of standard 24-byte messages. Table 6-2a shows that the RTU at the 5 oil-fired units will require 5.14 standard data messages every 2 s. In addition, 0.78-message (19 bytes) is required during two of each 15 scans, and a few other whole or partial messages must be accommodated at much longer intervals. These infrequent messages can be fitted into the 13 quiet spaces which occur during every 15 2-s scans. An allocation of 6.0 standard 24-byte messages every 2 s would seem to cover the current data collection requirements for this RTU. An allowance of 25% for future growth will increase this allocation to 7.5. For control purposes, one Type 3 message, "select before operate," will be allocated to the basic 2-s scan period. This will permit one critical command, requiring handshaking, during any or each 2-s scan period. Four messages of 3 data bytes each will be required for this function. Therefore, ten 3-byte poll messages; seven 24-byte; one 12-byte; and two 3-byte response messages, from/to this RTU, must be fitted into each 2-s slot at the ECC. The bit exchange requirement for this RTU proves to be 5 kb/2 s, or 2.5 kb/s.

The second complex at this generation plant, assumed to be equipped with its own RTU, consists of five combustion turbines, the same number of units as the oil plant. It seems reasonable to say that data requirements for this complex will be similar in nature and quantitatively the same, every 2 s.

The third generating complex, four nuclear units, would seem to be different, from the ECC point of view, primarily in the number of units under AGC. The data required to support this AGC function dominate the traffic. Therefore, the requirement for this RTU is estimated as 80%, or 4 kb/2 s.

Table 6-1. Scanning Requirements: Bulk Power Generation

Sensed Parameter	Functional Requirement	Data Type		Scan Interval						
		Analog	C and I	Ind.	MWh	2 s	10 s	30 s	10 m	1 h
<b>I. BULK POWER GENERATION</b>										
(a) Gross and net 3φ MW and MVAR each unit	Idi	x								
(b) Generation on/off status each unit	Ic		x							
(c) On/off status AGC controller each unit	Ic		x							
(d) Max and min output limits each unit	Iei	x								
(e) Max allowable short-term and sustained rate-of-change (MW/min) each unit	Iei	x								
(f) Status of switchyard breakers	Ic		x							
(g) Switchyard frequency	Id	x								
(h) Critical alarms	Ihk			x						
(i) Switchyard not bus indication	Ic		x							
(j) NCx, SOx and CO output each thermal units	Iek	x							x	
(k) Heat rate each thermal unit	Igk	x							x	
(l) Fuel consumption and heating value each thermal unit	Igk	x								x
(m) Water flow and pond levels each hydro unit	Ibk	x								x
(n) Fuel-oil tank status, level and temperature each tank	Ibk	x								x
(o) Gross and net MWh each unit	Igk									x
(p) Noncritical alarms	Ih			x						x
<b>II. INTERTIES</b>										
(a) 3φ MW and MVAR flow, each end of each line	Idefi	x								x
(b) Frequency, each end of each line	Idef	x								x
(c) MWh each line	Ih			x						x



Table 6-2a. Data Message Requirements, Generation Plant D: Oil-Fired Units RTU

Function	Analog Telemetry Points	Control and Indication Points	Binary Status Points	MWh Meter Points	Required Standard Messages	Scan Interval
<b>A. Oil-Fired Units RTU</b>						
(1) Gross and net MW and MVAR (3φ)	60				60/16	2 s
(2) Unit on/off status			5		5/192	2
(3) AGC controller on/off status			5		5/192	2
(4) Max and min output limits	10				10/16	2
(5) Max rate-of-change, short-term and sustained	10				10/16	2
(6) Status of generator breakers			5		5/192	2
(7) Critical alarms			12		12/192	2
				Subtotal	5.14	2 s
(8) NO <sub>x</sub> , SO <sub>x</sub> , CO output	15				15/16	30 s
(9) Heat rate	5				5/16	30
(10) Transformer temp	5				5/16	30
				Subtotal	1.56	30 s
(11) Fuel Consumptions	5				5/16	10 m
(12) Fuel heating value	5				5/16	10
(13) Oil-tank temperature, level	20				20/16	10
(14) Oil-tank status			20		20/192	10
				Subtotal	1.98	10 m
(15) Gross and net megawatt hours				10	10/8	1 h
				Subtotal	1.25	1 h

Table 6-2b. Data Message Requirements, Generation Plant D: Switchyard RTU

Function	Analog Telemetry Points	Control and Indication Points	Binary Status Points	MWh Meter Points	Required Standard Messages	Scan Interval
<b>B. Switchyard RTU</b>						
(1) Circuit breaker status			82		82/192	2 s
(2) Frequency	8				8/16	2
(3) Critical alarms			24		24/192	2
(4) Hit bus indication			24		24/192	2
(5) 3 $\phi$ MW and MVAR flow	54				54/16	2
(6) 1 $\phi$ MW and MVAR flow	20				20/16	2
(7) Hot line indication			57		57/192	2
				Subtotal	6.1	2 s
(8) 1 $\phi$ bus voltage	8				8/16	10 s
(9) 3 $\phi$ MW and MVAR flow each XFMR	18				18/16	10
(10) 3 $\phi$ voltage each XFMR	9				9/16	
(11) LTC position each XFMR		3			3/24	
				Subtotal	2.31	10 s
(12) 1 $\phi$ bus-tie MW and MVAR	8				8/16	30 s
(13) Weather data	5				5/16	30
(14) Transformer temperature	3				3/16	30
				Subtotal	1.0	30 s
(15) MWh each tie-line				3	3/8	1 h
(16) MWh each XFMR				3	3/8	1
(17) Noncritical alarms			21		21/192	1
				Subtotal	0.86	1 h

It is expected that, other than the AGC-related measurements, most of the parameters sensed will be quite different from oil-fired units. The number sensed and the scan rates, nevertheless, are assumed to be the same.

Table 6-2b addresses the telemetry requirements for the RTU concerned with the plant switchyard. Reasoning similar to that used for the oil-fired unit RTU yields a basic rate of 8.7 scan messages of 24 bytes and one Type 3 command every 2 s, or about 5.5 kb.

Similar analysis applied to the remote end of an intertie (see Table 6-1) yields a requirement of about 760 bits within a 2-s scan period. The near, or "in system" end of each intertie will have the same requirement. This intertie exchange data requirement is in addition to the normal requirements for monitor and control of bulk power substations. The intertie exchange data requirement is directly related to the bulk power generation AGC function and calculation of the area control error (ACE).

Detailed functional requirements for sensing within the transmission and subtransmission systems are shown in Table 6-3; the derived telemetry list for bulk power Substation C is given in Table 6-4. Allocation of all 2-s data plus one-third of the 10-s data to each 2-s scan period yields a requirement for 3.67 standard messages, or 4.6 if 25% growth is allowed. It seems that data of longer intervals can be inserted into the two blank periods that occur every five scans. Adding one Type 3 handshaking control results in a 3.3-kb exchange during a 2-s period.

The preceding analysis applies primarily to Generation Plant D and Bulk Power Substation C because they were high requirement examples. Estimating the total bulk supply portion of the model utility by these methods is beyond the scope of this study; therefore, averaging methods will be used. Examination of Table 6-2a shows that most of the data requirement depends on the number of units at the generating complex. The 25% growth allowance was for functional growth at each plant rather than additional units. The total requirement for generation monitoring is then estimated as follows because Plant D has 14 of the utility's 47 generation units:

$$0.75 \times 14 \text{ kb} \times \frac{47}{14} + 0.25 \times 14 \text{ kb} \times 6 \text{ plants} = 56 \text{ kb/2 s.}$$

Table 6-2b shows a dependence on the number of lines being monitored (25). The total number of switchyard lines is estimated to be 60; therefore, the requirement is:

$$5.5 \text{ kb} \times \frac{60}{25} = 14 \text{ kb/2 s.}$$

The total power plant data exchange requirement is, therefore, 70 kb/2 s.

Requirements for bulk power substations and switching stations are also driven by the number of transmission lines involved. In the nine substations there are about 129 lines, or an average of 14 lines per substation. Station C

Table 6-3. Scanning Requirements: Transmission/Subtransmission

Sensed Parameter	Functional Requirement	Data Type			Scan Interval				
		Analog	C and I	Ind. MWh	2 s	10 s	30 s	10 m	1 h
<b>III. TRANSMISSION/SUBTRANSMISSION</b>									
(a) Hot-line indication, each end of each line	Ic		x						x
(b) Hot-bus indication each bus	Ic		x						x
(c) Critical alarms	Ih		x						x
(d) Status each circuit breaker	Ic			x					x
(e) 3 $\phi$ MW and MVAR flow each end of each line, 345 kV or higher	Ie1			x					x
(f) 1 $\phi$ voltage each bus	Id			x					x
(g) 3 $\phi$ MW and MVAR flow each XFMR bank	Ie1			x					x
(h) 3 $\phi$ secondary voltage each XFMR bank	Ie			x					x
(i) LTC tap position each XFMR bank	Ic			x					x
(j) 1 $\phi$ bus tie MW and MVAR	Ii			x					x
(k) Weather data	Iik			x					x
(l) Temperature each transformer bank	Ii			x					x
(m) 1 $\phi$ MW and MVAR each end of each line 138 kV or lower	Ie1			x					x
(n) MWh each XFMR bank	Ik							x	
(o) Non-critical alarms	Ih			x					

Table 6-4. Data Message Requirements: Bulk Power Substation C

Function	Analog Telemetry Points	Control and Indication Points	Binary Status Points	MWh Meter Points	Required Standard Messages	Scan Interval
<b>C. Bulk Power Substation RTU</b>						
(1) Hot-line indication each line			75		75/192	2 s
(2) Hot-bus indication each bus			42		42/192	2
(3) Critical alarms			22		22/192	2
(4) Status each circuit breaker			67		67/192	2
				Subtotal	1.07	2 s
(5) 3 $\phi$ MW and MVAR each 345-kV line	42				42/16	10 s
(6) 1 $\phi$ voltage each bus	16				16/16	10
(7) 3 $\phi$ MW and MVAR each XFMR	42				42/16	10
(8) 3 $\phi$ secondary voltage each XFMR	21				21/16	10
(9) LTC position each XFMR		6			6/24	10
				Subtotal	7.81	10 s
(10) 1 $\phi$ bus-tie MW and MVAR	20				20/16	30 s
(11) Weather data	5				5/16	30
(12) XFMR temperature	7				7/16	30
(13) 1 $\phi$ MW and MVAR 138 kV or lower lines	36				36/16	30
				Subtotal	4.25	30 s
(14) MWh each XFMR				7	7/8	1 h
(15) Noncritical alarms			18		18/192	1 h
				Subtotal	0.97	1 h

involves 25 lines; therefore, the average data exchange requirement is estimated to be  $14/25 \times 3.3$  kb or about 1.8 kb at the 2-s rate. The bulk supply substations will then require about 65 kb/2 s. Table 6-4 shows that about one-half of the data requirement is transformer associated, and will not be applicable to switching stations. Therefore, the requirement for the 6 switching stations is estimated to be  $1.8/2$  kb  $\times$  6 or about 6 kb/2 s. An allocation of 6 kb each 2 s is added to each total to handle the near end of interties (12 kb total).

The data requirements estimated above are shown in Figure 6-1 in bits per second. To complete the on-line operational requirements for the ECC, several other links must be estimated. Interchange scheduling, for example, is commonly calculated five times per hour. In our example utility, there are 15 intertie lines. The required information can be contained in one standard 24-byte message and should be received within 2 s after calculation. This size message provides space for both measured and planned  $3\phi$  MW and MVAR plus 6 additional 5-bit bytes. The required rate is:

$$(174 + 366) \text{ bits} \times 15 \text{ interties} = 8 \text{ kb/2 s}$$

Data exchange with the large industrial substations will be small, with a few control and indication points and alarms. On the average, one 3-data-byte message every 10 s should suffice, which is 348 bits. This totals about 2800 bits per 2-s period for these 46 links.

The data requirement for a regional power pool control center will be comparatively small, as only high-level control instructions are presumed. Information describing gross real and reactive power dispatch, spinning and standby reserve, schedule, and load prediction seems appropriate. One standard 24-byte data message every 2 s plus nonreal-time information in hourly and daily batches should suffice. Also, a standard 3 byte, Type 1 control message is provided for in each basic scan period. The data exchange requirement is then about 2 kb/2 s. These final requirements for real-time operational control of the bulk power system are also shown in Figure 6-1. In summary, the gross data exchange requirements are:

Bulk Power Generation	45.5 kb/s
Transmission and Subtransmission	<u>43.4 kb/s</u>
Total	88.9 kb/s

#### B. ON-LINE OPERATIONAL REQUIREMENTS: DISTRIBUTION SYSTEM

The requirements for the bulk power system were developed to be consistent with current state-of-the-art utility practices. Some functional projections were made and a 25% capacity increment was provided to accommodate future needs. All major elements were included in a continuous, automated monitoring program. Final estimates were checked against current "real-world" utility practice for validity.

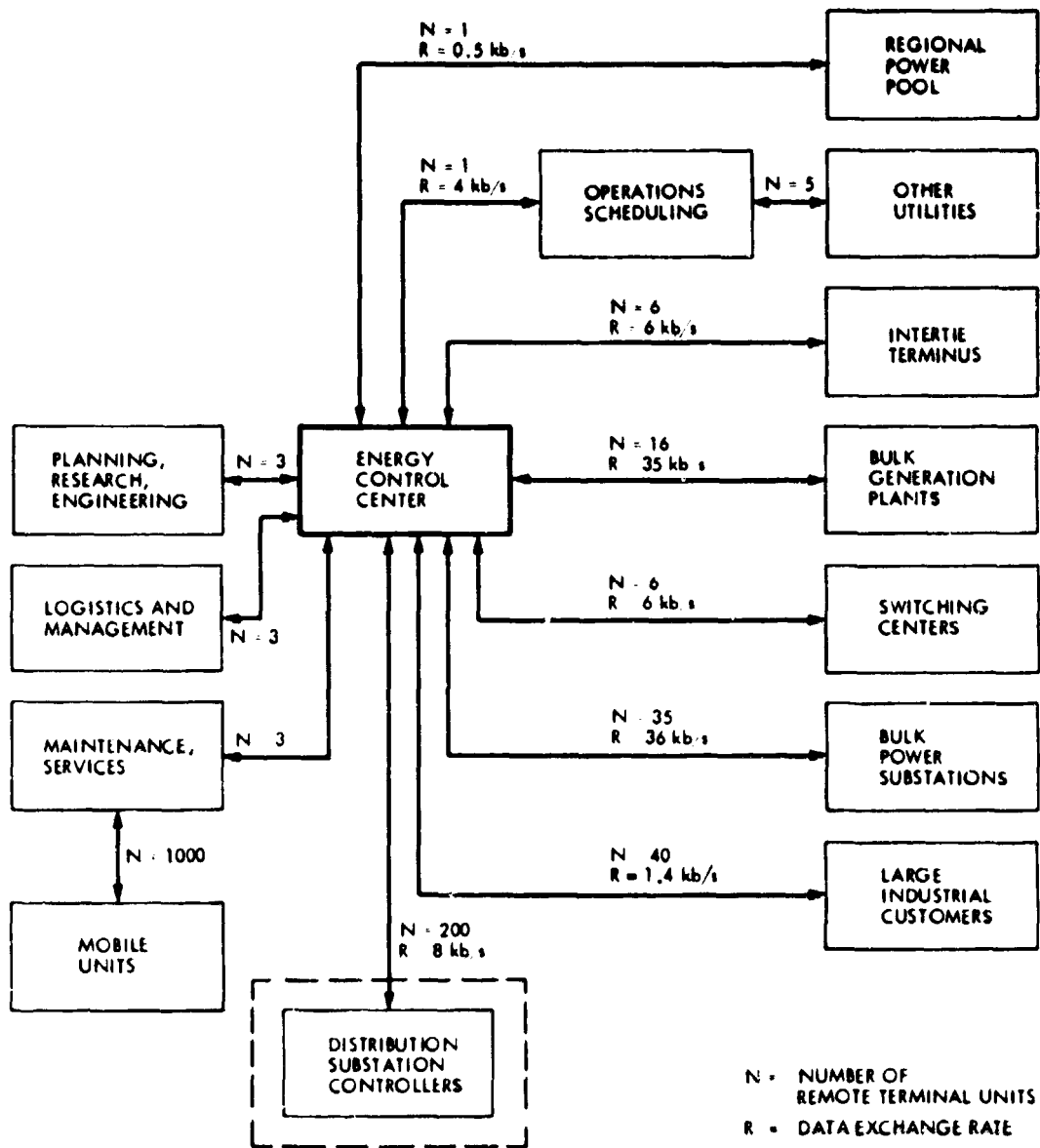

Figure 6-1. Energy Control Center Data-Flow Diagram

For the most part, the distribution systems are not automated. Where exploratory automation has been undertaken, the scope is often functionally restricted by the communications technology selected. No such restrictions were imposed in this study, which largely eliminates the possibility of real-world verification. Furthermore, some of the power system elements considered here to be under monitor and control only exist only in experimental form. The results presented are, therefore, largely speculative in nature. For this reason, care was taken to record assumptions and to "lay a track," which can be modified in the future as the real world progresses toward the automated distribution system.

A key assumption of this study is that the distribution system is managed by local controllers, located at the distribution substations, which respond to high-level (not detailed) instructions from the ECC. The analysis begins with the functions and interfaces diagram for this controller, as shown in Figure 4-3. The functional requirements for regular data collection have been tabulated in Tables 6-5 and 6-7, and the concomitant sensing or telemetry lists are presented in Tables 6-6 and 6-8 for the distribution substation shown in Figure 3-8. It has been assumed here that all sensors at the distribution substation itself are hardwired to the local controller, and the collected data are largely used in local decision making or stored in logs. No communications traffic results from these activities. Some of these data will also be transferred from the DSSC to the ECC, and these requirements are developed later.

The data scan list for remote devices is shown in Table 6-6. Line voltage is measured at the voltage regulators; otherwise each device has its own RTU. The various communications requirements to the average DSSC are:

Voltage:	$(174 + 198) \text{ bits} \times 6 \text{ devices} \times \frac{1}{30} \text{ s} = 75 \text{ b/s}$
Capacitors:	$(174 + 182) \text{ bits} \times 6 \text{ devices} \times \frac{1}{30} \text{ s} = 72 \text{ b/s}$
Switches:	$(174 + 182) \text{ bits} \times 24 \text{ devices} \times \frac{1}{30} \text{ s} = 285 \text{ b/s}$
Power:	$(174 + 198) \text{ bits} \times 6 \text{ devices} \times \frac{1}{30} \text{ s} = \frac{75 \text{ b/s}}{507 \text{ b/s}}$

Since all of these devices must report to the DSSC each 30 s, the required communications rate into the DSSC for these functions is the sum, or a modest 507 b/s. One Type 1 (no response required) command was allocated to be transmitted within a 2-s period, resulting in total requirement for these functions of 681 b/s, or 850 b/s with a modest allowance for growth.

The sensed parameter list for large and intermediate DSGs (several megawatts and up) is given in Table 6-7 with the companion telemetry list for a single DSG of this class is shown in Table 6-8. The functions scanned are those necessary for AGC and dispatch and are similar to those used in the bulk power system. Six special analog measurements have been allocated to sense quantities peculiar to the DSGs. These might include such items as:



Table 6-5. Scanning Requirements: Distribution Substation

Sensed Parameter	Functional Requirement	Data Type			Scan Interval				
		Analog	C and I	Ind. MWh	2 s	10 s	30 s	10 m	1 h
<b>IV. DISTRIBUTION SUBSTATION</b>									
(a) Hot line and bus indication	IIbe			x				x	
(b) Circuit breaker/switch status	IIbe			x				x	
(c) Critical alarms	IIjke			x				x	
(d) 1 $\phi$ bus voltage	IIdi	x							x
(e) 1 $\phi$ MW and MVAR input lines	IIC	x							x
(f) 1 $\phi$ MW and MVAR primary feeders	IIcd	x							x
(g) 3 $\phi$ Secondary voltage each XFMR	IIfk	x							x
(h) LTC Tap position each XFMR	IIdke			x					x
(i) 3 $\phi$ MW and MVAR each XFMR	III	x							x
(j) Temperature each XFMR	IIlk	x							x
(k) Shunt capacitor switch status	IIbi			x					x
(l) MWh each XFMR	IIk								x
(m) Non-critical alarms	IIk			x					x
<b>V. REMOTE DEVICES</b>									
(a) Feeder voltages	III	x							x
(b) Voltage regulator position	IIbdie		x						x
(c) Capacitor switch status	IIddie			x					x
(d) Feeder switch/breaker status	IIbdie			x					x
(e) MW and MVAR flows	IIdci	x							x

Table 6-6. Data Message Requirements: Distribution Substation

Function	Analog Telemetry Points	Control and Indication Points	Binary Status Points	MWh Meter Points	Required Standard Messages	Scan Interval
<b>D. Distribution Substation (Figure 3-8)</b>						
(1) Hot-line and bus indication			99		99/192	10 s
(2) Circuit breaker/switch status			43		43/192	10
(3) Critical alarms			15		15/192	10
				Subtotal	0.82	10 s
(4) 1 $\phi$ bus voltage	10				10/16	30 s
(5) 1 $\phi$ MW and MVAR feeders and lines	20				20/16	30
(6) 3 $\phi$ XFMR secondary voltage, MW and MVAR	27				27/16	70
(7) LTC tap position		3			3/24	30
(8) Transformer temperature	3		6		3/16	30
(9) Shunt capacitor switch status					6/192	30
				Subtotal	3.91	30 s
(10) Transformer megawatt hours	3	3/8	1 h		14/192	1
(11) Noncritical alarms			14			
				Subtotal	0.45	1 h
<b>E. Remote Distribution Devices</b>						
(1) Feeder voltages, 1	13				13/16	30 s
(2) Voltage regulator position		13			13/24	30 s
(3) Capacitor switch status			13		13/192	30 s
(4) Feeder breaker/switch status			52		52/192	30 s
(5) MW and MVAR flows	26				26/16	30 s

Table 6-7. Scanning Requirements: Dispersed Storage Generation

Sensed Parameter	Functional Requirement	Data Type		Scan Interval						
		Analog	C and I	Ind.	MWh	2 s	10 s	30 s	10 m	1 h
<b>VI. LARGE- AND INTERMEDIATE-SIZED DSGs</b>										
(a) Gross and net MW and MVAR flow	IIIf	x							x	
(b) Frequency	IIIi	x							x	
(c) Special analogs (by DSG type)	IIIfi	x							x	
(d) Generate on/off and line switch status	IIbK			x					x	
(e) Charge on/off status (batteries)	IIbd			x					x	
(f) AGC controller on/off status	IIbdK			x					x	
(g) Max and min output limits	IIIi	x							x	
(h) Short-term and sustained rate-of-exchange limits (MW/min)	IIIi	x							x	
(i) Critical alarms	IIeiJ								x	
(j) Noncritical alarms	IIk			x						x
(k) MWh in/out	IIk				x					x
<b>VII. SMALL DSGs</b>										
(a) Generate on/off and line switch status	IIbed			x						x
(b) kW and KVAR flow	IIid	x							x	
(c) Frequency	IIid	x							x	
(d) Alarms	Ile			x					x	
(e) Kilowatt hours in/out	IIk				x					x

Table 6-8. Data Message Requirements: Dispersed Storage Generation

Function	Analog Telemetry Points	Control and Indication Points	Binary Status Points	MWh Meter Points	Required Standard Messages	Scan Interval
<b>F. Large- and Intermediate-Sized DSGs and RTUs</b>						
(1) Gross and net MW nad MVAR (3 $\phi$ )	12				12/16	2 s
(2) Frequency	1				1/16	2
(3) Special DSG analog	6				6/16	2
(4) Generate on/off and line switch status			3		3/192	2
(5) AGC controller on/off status			1		1/192	2
(6) Max and min output limits	2				2/16	2
(7) Short-term and sustained rate-of-change limits	2				2/16	2
(8) Critical alarms			10		<u>10/192</u>	<u>2</u>
				Subtotal	1.51	2 s
(9) Megawatt hours in/out				2	2/8	1 h
(10) Noncritical alarms			20		20/192	1
				Subtotal	0.35	1 h
<b>G. Small DSG RTU</b>						
(1) Generate on/off and line switch status			2		2/192	30 s
(2) kW and kVAR flow	2				2/16	30
(3) Special analog	1				1/16	30
(4) Alarms			5		5/192	30
				Subtotal	0.22	30 s
(5) Kilowatt hours in and out				2	2/8	1 h
				Subtotal	0.25	1 h

- (1) Harmonic content of delivered power when dc source is inverter-coupled to utility.
- (2) Solar insolation, cloud characteristics.
- (3) Charge level and temperature of batteries.
- (4) Fuel supply and properties at co-generator or fuel cell.
- (5) Wind velocity and direction.

The data exchange requirement for scanning proves to be 620 b/2 s. Providing space for one Type 1 command results in 794 bits, or a rate of 400 b/s. As there are fewer DSGs of this class than substations, a worst-case, rather than average, example will be used. The substation of Figure 3-8 is supported by 3 units, yielding a total rate of about 1.2 kb/s.

Smaller DSGs (about 75 kW) are presumed to operate somewhat autonomously, delivering power to the system when: (1) it is available, and (2) when the utility is willing to accept it. No generation control is envisioned, only status monitoring and a disabling capability. The monitoring data exchange requirement is 174 + 198 b/unit each 30 s. This scan can be interrupted to insert a turn-off command or to collect energy data. The requirement is therefore 12.4 b/s. The total requirement is 186 b/s for the 15 units connected to the substation of Figure 3-8.

The information needed to make load management decisions has been collected in support of other functions. The data flow requirement remaining is that which is needed only to reduce load. Although several strategies have been discussed in the literature, it has been assumed here that service will automatically be restored about 10 to 15 min following an interrupt command. Therefore, prolonged interruption will require a control command every 10 min. Furthermore, block addressing is assumed in which one-sixth of the customers can be controlled by a single command. Because it is desirable to achieve the intended response within a few seconds, the requirement will be for one Type 1 command in 5 s or about 35 b/s. Complete disabling of all load management customers could then be achieved in 30 s.

The final real-time operational requirement is the information exchange between the DSSC and the ECC. The ECC will need appropriate monitor data from the subtransmission terminations at the substation. These data will include  $1\phi$  MW, MVAR, and voltage readings at 30-s intervals for each line plus hot line and bus indication. The ECC will require some general status data on substation conditions, such as critical alarms and transformer temperatures. The ECC will require some DSG information such as net MW and MVAR delivery, one or two special analogs, and a few status indications. Load management strategy and mode information will also be of interest, and supervisory instructions must be sent to the DSSC from the ECC. Table 6-9 lists the message requirements for an average substation with two subtransmission feeds and two transformer banks. Also shown are DSG requirements for a single DSG. Data exchange between the ECC and all the distribution substations was estimated by assigning one large/intermediate DSG to each of 55 substations and by allowing one 3-byte supervisory message to each substation for each 30-s scan. The resulting exchange per substation is 934 b/30 s for each non-DSG station and 1140 with

Table 6-9. Data Message Requirements: ECC to DSSC

Function	Analog Telemetry Points	Control and Indication Points	Binary Status Points	MWh Meter Points	Required Standard Messages	Scan Interval
<b>H. ECC to DSSC Exchange</b>						
(1) Subtransmission $1\phi$ MW and MVAR	4				4/16	30 s
(2) Subtransmission voltage	2				2/16	30
(3) Hot-line and bus indication			12		12/192	30
(4) Substation alarms			5		5/192	30
(5) XFMR temperature	2				2/16	30
(6) Load management status		1			1/24	30
				Subtotal	0.63	30 s
(7) DSG MW and MVAR plus 2 special analogs	4				4/16	30 s
(8) DSG status			4		4/192	30
				Subtotal	0.27	

one DSG. Summing these for all 200 substations gives 8 kb/s for this function. Figure 6-2 shows the results of the above calculations for a representative distribution substation.

The total distribution system data exchange can now be estimated for the complete utility:

Distribution automation:	850 b/s x 200 =	170 kb/s
DSG monitor (large):	400 b/s x 55 =	22 kb/s
DSG monitor (small):	12.4 b/s x 1800 =	23 kb/s
Load mangement:	40 b/s x 200 =	<u>8 kb/s</u>
		223 kb/s

This requirement is dominated by the distribution automation function. This requirement results from the low-message efficiency of the protocol when small amounts of data are to be transmitted. For example, knowledge of the status of a remote switch (open or closed) requires one bit (a zero or a one). Using the assumed protocol and preamble time results in 324 procedural bits associated with the single data bit.

Although it is probable that the protocol used was not intended for application to situations where very little information is requested from an RTU, some procedural overhead is still necessary. A simpler protocol for the distribution system might reduce the overhead by 25 to 30%. Another simplifying modification would be to require status response messages from pole-mounted capacitors and remote switches only when status has changed, or once each hour to indicate that the RTU is functioning. Such infrequent messages could be substituted for regular scan messages of lower priority. These simplifying procedural changes can reduce the distribution automation requirement to about 85 kb/s, which is about equal to that for the entire bulk power system -- generation and transmission combined.

The actual requirement for the 100-bit equivalent preamble allowance that has been associated with each message depends on the design of the communication system selected, and could be made very small. The result could be a reduction in data exchange requirement for the distribution system of about one-half. This still leaves a large amount of data to be transmitted because of the large number of discrete terminal units involved.

### C. SUPPORT AND ADMINISTRATIVE REQUIREMENTS

The communications requirements associated with the support and administrative functions will be estimated within the following paragraphs. These requirements are represented by the boxes on the left side of Figure 6-1. Much of this traffic cannot be specified in terms of information bits exchanged within a prescribed time period, as was done for the operational links. For these cases, estimates will be made of the number of dedicated channels required and their associated capacities.

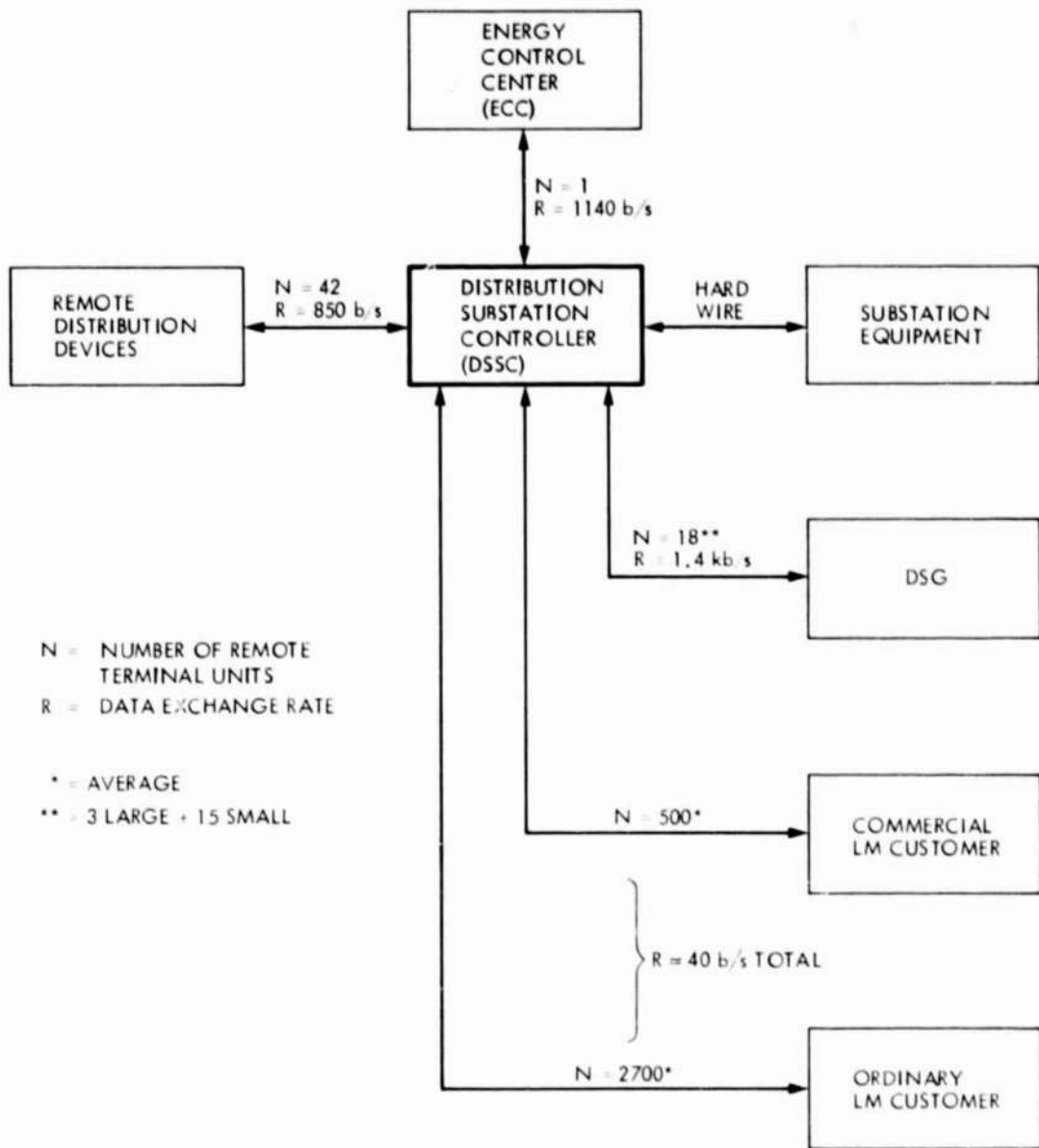

Figure 6-2. Representative DSSC Data-Flow Diagram



In Figure 6-1, about 1000 mobile units have been allocated to this hypothetical utility. A scenario was developed describing how these units might be dispatched. These are summarized in Table 6-10, where average channel utilization ( $\bar{u}$ ) is computed as follows:

$$\bar{u} = \text{Number of units} \times \text{average message time} \times \text{message frequency}^1$$

The average waiting time for a clear channel is then given by:

$$\bar{t}_{\text{wait}} = \frac{\bar{u}}{1 - \bar{u}} \times \text{average message time}^1$$

The average wait time was felt to be unacceptably long in several cases; therefore, additional channels were allocated. The total estimated requirement for this function is then 10 separate, dedicated channels for voice communication, i.e., 3-kHz bandwidth. This estimate compares favorably with that of a local utility that has about 2500 mobile units and 20 channels assigned.

It is assumed that maintenance and service functions are operated from three centers strategically located within the service area. At least one, and perhaps two, dedicated voice/data channels of about 3-kHz bandwidth connecting each with the ECC will be required. These channels will be used to collect and transfer stored maintenance data, transmitting alarm information and dispatching repair crews, for facsimile transmission or graphic or printed information.

The remaining boxes related to engineering and administration are assumed to require three dedicated channels each of a 3-kHz bandwidth for voice/digital data, or facsimile transmission. These will be used to call up information stored at the ECC, exchange information with the ECC, or use its computing capacity, as available, to support these off-line functions. A requirement for video teleconferencing would greatly increase this requirement.

Several other functions need to be considered which are not obvious from the data flow diagrams. These functions are meter reading, backup voice channels for real-time operations, and remote video monitoring. Meter reading can be approached in terms of digital data exchange similar to that used for the on-line operations. Each DSSC will interrogate each of its meters during an 8-h period (about once per month). Each meter has two registers of five decimal digits, and this information will be stored at the DSSC. A standard poll message of 174 bits will be required for each meter, and a 214-bit response. The required data exchange rate for the average DSSC is:

$$3.2 \times 10^3 \text{ meters} \times 388 \frac{\text{bits}}{\text{meter}} \times \frac{1}{2.9 \times 10^4 \text{ s}} = 43 \text{ b/s.}$$

---

<sup>1</sup>The following queuing assumptions have been made:

- (1) The message time follows an exponential distribution.
- (2) Message arrivals follow a Poisson distribution.
- (3) The variance of message time equals the mean.

Table 6-10. Mobile Unit Channel Analysis

Unit Assignment	Transaction Types	Message Time, s	Message Frequency, h	Number of Units Dispatched	Channel Utilization	Average Wait Time, s	Analysis
Customer Relations	2S + 1D	40	1	100	0.11	5	Underused
Preventive Maintenance	4S + 1B	210	8	100	0.73	565	Need 2 channels
Corrective Maintenance	1S + 2B	150	2	50	1.04	INF	Need 3 channels
Fault Isolation and Repair	2S + 1D + 2B	180	4	25	0.31	81	
Construction	2S + 2B	95	4	100	0.66	184	Need 2 channels
Supply	1S + 1D	35	1	50	0.48	32	

Transaction type code:  
 S = Status report (5 to 10 s)  
 D = Dispatch (25 s)  
 B = Block data (60 to 80 s)

This relatively low data rate produces a considerable amount of information to be stored at the DSSC or forwarded, about  $2 \times 10^5$  combined address-and-register data bits. If all DSSCs forward their data to the ECC during this or some other 8-h period, the required rate can be found as follows:

$$6.4 \times 10^5 \text{ meters} \times \frac{540}{3} \text{ bits/meter} \times \frac{1}{2.9 \times 10^4 \text{ s}} = 4 \text{ kb/s.}$$

This information can also be stored at the ECC or forwarded. The storage requirement would be 200 times that for a DSSC,  $4 \times 10^7$  bits. Or it could be forwarded to the billing computer in 8 h at the rate of 4 kb/s. These data exchange rates are only examples, and other strategies are readily available which will result in much lower (or much higher) rates.

All real-time operations, other than at the ECC, are normally conducted in the unattended mode, i.e., no people are directly involved in the control loop. Backup voice channels are required, at least to the DSSC level to permit manual operation in the event of RTU/controller failure and to support troubleshooting. The requirement would be for voice channel (3-kHz bandwidth) capability from the ECC to each of 265 remote RTU/controller locations. Although the actual total bandwidth, or dedicated channel requirement, will depend upon the mechanization, it seems reasonable that considerable sharing would be possible. Referring to Table 6-10, the information transaction might be similar to that for corrective maintenance. If one allows for 25 to 50 units in distress at a given time, three voice channels would seem adequate.

The final estimated requirement is for remote video monitoring. For safety and security purposes, there is a remote video monitoring capability installed at each of the transmission system switching centers and bulk power substations, and at one-quarter of the distribution substations (about 90 sites total). Furthermore, the ECC will have switchable display capability to monitor five of these sites at any given time. If the standard commercial format (512 lines x 640 pixels/line) and an 8-bit, grey-tone scale are used, each picture frame will require about 2.7 Mb. Using the slow-scan concept at 1 picture/s results in 2.7 Mb/s; five pictures will then require 13.5 Mb/s. If lower resolution or slower scan rates are acceptable, this requirement can be significantly reduced. For example, a 300 x 300 format and 2 1/2-s scan rate reduces the data rate by a factor of almost 10 (and will provide pictures of the quality of the Mariner 64 pictures of Mars taken in 1964). On the other hand, development is currently underway in video compression technology which could conceivably provide broadcast, rather than slow scan, quality video at 1 to 1.5 Mb/s in the future.

## SECTION VII

### TRAFFIC REQUIREMENTS ANALYSIS

#### A. SUMMARY

The data exchange/communications traffic requirements which were developed in the previous section will be summarized, and the appropriateness of various communications technologies will be addressed. In developing these requirements no allowance was made for such factors as message spacing, turn-around time, or error correcting. Hence, the data rates presented do not constitute a link performance specification, but rather represent one step in its development. It should be emphasized that, for the digital data exchanges:

- (1) Half-duplex operation was assumed in all cases.
- (2) A poll message from the master was required for each response message from an RTU.
- (3) Preamble time of 100 bits was allowed for each poll-and-response digital message.
- (4) Many real-world situations will have significantly more devices per distribution feeder than were used in the average case considered here.

With reference to the reservations stated above, Table 7-1 summarizes the data rate requirements to the DSSC for a substation having 6 feeders, 15 small (about 75 kW) DSGs, and 3 large/intermediate (>1 MW) DSGs. The overall requirement far exceeds the existing capability on the order of 20 to 100 b/s of Ripple or Power line Carrier communications systems. That level of technology can handle the load management and meter reading functions, which need

Table 7-1. Traffic Summation for Typical Distribution Devices to Substation Controller

Function	Data Rate, b/s
Distribution Automation	850
Load Management	40
Small DSG Management (15 units)	190
Meter Reading	<u>70</u>
Subtotal	1150
Large/Intermediate DSG Management (3 units)	<u>1200</u>
Total	2350

not be performed simultaneously and therefore whose requirements need not be summed. In fact, active demonstrations and commercial use of that capability are currently underway in numerous utilities. However, a very considerable improvement in performance (an order of magnitude or more) will be required to support the distribution automation and DSG management functions, even assuming separate links/systems for the larger DSGs. The overall rate requirement seems to be well within the capability of most of the candidate technologies such as telephone, radio, microwave, coaxial cable, optical fibers or satellite. In fact, use of one of the higher capacity technologies for this service alone would probably be quite inefficient, and not cost effective, unless the channel were shared with another service or other utility functions.

The existing switched telephone network is easily compatible with the data rates required. It is also highly flexible in point-to-point connectivity, and provides essentially complete coverage and penetration of the service area of any given utility. However, conduct of the distribution automation functions via switched circuits is probably precluded by the long interrogation delay associated with establishment of a single connection ( $\approx 5$  s). With many devices to be polled, the scan period required seems to be unacceptably long. As an alternative, private telephone lines to all the various distribution RTUs would not seem to be economically feasible. Neither private lines nor the switched network can be used in the broadcast mode for load management functions. A rapid scan system which approximates broadcasting can be devised by paralleling the telephone central office switch with a scanning matrix interfaced directly with the customer loops. It is not clear at this time whether it is technically and economically feasible to employ this approach in scanning remote distribution devices for purposes of monitor and control. This is because telephone company and utility service areas are frequently incongruent, causing multiple interfaces. A directed microwave, while embodying the necessary inherent data exchange capability, is certainly much too expensive for serious consideration in most distribution system applications due to the complex topology.

On the other hand, UHF or VHF radio embodies the broadcast capability desired, and existing bandwidth allocations seem to provide adequate data exchange rate capability. Coverage of all points of interest in the area is the largest problem. The received signal at certain locations will undergo deep fades as a result of multipath propagation. Other points will be subject to large attenuation losses as a result of terrain, foliage or building obstacles. Multiple antennas and judiciously placed reflectors can help to alleviate these problems, but the achievement of total coverage with small remote antennas may be difficult.

Dedicated coaxial cable for the distribution system would not seem cost effective, while existing CATV suffers from both low penetration and lack of current two-way capability. The industry, however, is growing rapidly and both of these factors can be expected to improve in the future. As with the telephone network, CATV service areas are frequently incongruent with utility service areas; thus, multiple interfaces would exist with data concentrations at several CATV headends.

Satellite-supported communications for the distribution system seem to be technically feasible; however, serious economic concerns exist. These concerns arise primarily from ground station cost considerations because tariffs

are so small they are almost negligible. Existing and planned communications satellites employ small antennas which provide large-area (continental United States) coverage and also use relatively low-power transmitters. As a result, relatively high performance is required of the ground station. Interference, both to and from the ground stations and with other nearby satellites is another consideration. (The satellites are currently spaced about 4 deg apart at the geostationary altitude, 35,405 km.) As a result, the FCC has not authorized the use of ground station antennas smaller than 4.5 m with current C-band (4/6 MHz) satellites. An application has been filed with the FCC to permit use of 3-m antennas, but approval has not been granted at this time. Even so, a 3-m ground station would not be appropriate for most distribution system applications and would still be too expensive (about \$30K). The small, inexpensive ground terminal needed for serious consideration in the distribution system, (exclusive of larger DSGs and the substation) must wait for new satellite technology which places more of the burden with the satellite and less with the ground station. The development of such technology is the subject of planning currently underway within NASA, with special emphasis on the land mobile service. Those interested in a more comprehensive analysis of the application of satellite communications to the electric power utilities are referred to Reference 11, Satellite Applications to Electric Utility Communications Needs.

Typical data rates for the various monitor and control links connected to the ECC are shown in Table 7-2. The individual link requirements far exceed the capability of many of the mechanizations now being proposed or used for simple load management and meter reading. They are, however, well within the normal channel capacities of twisted pair, directed microwave, or other high-speed carrier services such as coaxial cable, satellite and optical fibers. With some reservations, the same remarks concerning efficiency and shared service can be made here. As most of these links carry information of vital concern to the utility, system reliability requirements are expected to be very high. Fully dedicated systems of higher than normal commercial reliability are expected to continue to be the rule.

Table 7-2. Typical Data Requirements: ECC Links

ECC Link To	Bit Rate, kb/s
Regional Pool	0.5
Scheduling	4.0
Intertie Terminus	1.0
Generation Plant D	20.0
Switching Center	1.0
Bulk Power Substation C	3.3
Large Industrial Customer	0.1
DSSC	0.1
Total	30.0

Unlike the distribution system, the number of communications nodes to the ECC is relatively small, the consequences of communication loss are often severe, and the capital investment in equipment to be controlled is large. An investment of \$75K per site for a fully redundant satellite terminal using a 4.5-m antenna is a much more reasonable prospect. Current C-band satellites which permit multiple transponder access by narrowband carriers are available for this purpose. A set of satellite links to the various bulk power system sites would constitute a highly independent and flexible network for either primary or backup service.

Typical channel requirements for administrative/support functions are summarized in Table 7-3. The service to mobile units can be provided by UHF-VHF radio, as is now commonly done, or by satellites of the Land Mobile Satellite System (LMSS) type. The fixed point-to-point links can be supported by any of the previously mentioned technologies. Remote video monitoring, shown in the table at a rate well below that for standard commercial video, could best be served by directed microwave, coaxial cable, optical fibers, or satellite.

Table 7-4 summarizes the monitor and control traffic for the entire utility. This is of particular interest when considering approaches wherein all traffic passes through one, or a few, points such as a broadcast radio station or satellite transponder. The total data exchange rate, half duplex, is about 300 kB/s. Typical current C-band satellite capacity, using 4.5-m ground stations, is on the order of 20 Mb/s. It is not fair to compare these numbers because large, expensive ground stations would not be used in the distribution system; however, it is clear that the probable future traffic for a large utility is very small compared to the capacity of even one typical transponder. (Current satellites frequently have 12 to 24 transponders.) As the number of customers connected to this utility is about 1% of that estimated for the nation in the year 1995, a national bit rate of 30 Mb/s can be projected which is still small in satellite-capacity terms. Adding the administrative and support requirements of Table 7-3, excluding "remote video monitoring," increases the requirements by only about 25%. There are strong drivers to increase the capacity of future satellites, but it seems unlikely that the electric power utilities of the nation could prudently use more than a relatively small fraction of a single satellite's capability. Thus a shared service with users having similar requirements seems most likely when considering satellite technology.

## B. CONCLUSIONS AND RECOMMENDATIONS

A method has been described and an estimate made of the communications traffic related to the operation of a representative, but hypothetical, utility. This utility serves about one million customers, uses sophisticated and highly automated methods for monitor and control, and derives about 5% of its power from distributed sources and generators using new energy technologies. Excluded from this estimate are intrasite communications, normal business telephoning, and protective relaying. With the exception of Ripple/PLC, which currently have very low data rate capability, most of the current technology alternatives are capable of handling most of the traffic associated with those functions considered here. Performance can be very sensitive to mechanization, i.e., some concepts for utilizing commercial AM or FM radio result in data rates of

Table 7-3. Voice/Data Support Channel Summary

Function	Channel Bandwidth, kHz	Number of Channels	Total Bandwidth, kHz
Mobile Units (Voice)	3	10	30
Maintenance/Service to ECC (Data)	3	6	20
Engineering/Administration to ECC (Data)	3	6	20
Critical Remotes to ECC (Voice)	3	3	10
Remote Video Monitoring	300	5	<u>1,500</u>
		Total	1,580

Table 7-4. Synthetic Utility Control Data Exchange Summary

Function	Data Rate, kb/s
Bulk Power Generation	46
Transmission/Subtransmission	44
ECC to DSSC	8
Distribution	222
(1) Distribution Automation	170
(2) DSG (> 1 MW) Control (55 Total)	22
(3) DSG (~ 75 kW) Control (1800 Total)	23
(4) Load Management	7
Total	<u>320</u>



only a few bits per second. It would seem that in selecting an appropriate communications technology for a given service, factors other than the data rate requirement will play a powerful role. Cost, reliability, tariffs, regulations, interface constraints, flexibility and growth potential are examples of such factors. However, certain basic characteristics of the information exchange requirement must be kept in mind. It is hoped that this document can help to quantify them. In particular, it appears that automated monitor and control of the distribution system and extensive integration of DSGs will have a very significant impact on utility communication traffic.

The major drivers which are expected to lead to expanded communications or utilization of new technologies are in the near-term future. Nevertheless, there appear to be a number of actions which can be undertaken now which will help prepare for that future. The following are recommendations for follow-on activities.

- (1) A much more descriptive and realistic model of the distribution system should be developed. This model can be used to better assess the impact of various operational alternatives, to better explore the issues of various communications alternatives, and to develop more realistic communications and control strategies.
- (2) Identification of the peculiar monitor and control requirements of each of the candidate DSG technologies. These can then be used to generate appropriate telemetry lists.
- (3) Identification of the special communications and control requirements of the major transmission utilities or agencies such as TVA, Bonneville, etc. These were not included in this study, which would be more complete by their addition.
- (4) Formulate an experimental program for investigating, in partnership with a utility, the key issues regarding the support of monitor and control traffic with communications satellites.
- (5) Identify other potential users having similar requirements who might share a high-speed communications network and estimate their traffic. Such users might include oil and gas distribution, production, and exploration companies, medical data exchange networks, and emergency warning networks.

## REFERENCES

1. Kirkham, H., Nightingale, D., and Koerner, T., Energy Management System Design with Dispersed Storage and Generation, Paper 81 WM 211-2, to be presented at IEEE PES Winter Meeting, February 1-6, 1981.
2. The Automated Distribution System: An Assessment of Communications Alternatives, prepared by Mitre Corporation for the Electric Power Research Institute, Vols. I and II, Report EPRI EL-157, September 1976.
3. Customer Communications Task Force, Customer Communications Systems, EEI Publication 78-29, Edison Electric Institute, 1978.
4. Mouneimne, S., Distribution Automation and Control on the Electric Power System - Preliminary Requirements Analysis, JPL Internal Document 5030-322, May 31, 1979.
5. Monitoring and Control Requirement Definition Study for Dispersed Storage and Generation (DSG), Volumes I-V, Prepared by General Electric Company for the Jet Propulsion Laboratory and New York State ERDA (to be published).
6. Vaisnys, A., A Study of Space Communication System for the Control and Monitoring of the Electric Distribution System, JPL Publication 80-48, Vols. I and II, May 1980.
7. Synthetic Electric Utility Systems for Evaluating Advanced Technologies, prepared by Power Technologies Incorporated, Report EPRI EM-285, February 1977.
8. Crask, G. J., Gavshell, D. J., and Koing, D. F., IEEE Recommended Practice for Master/Remote Communications, Working Paper WG 77.1, Revision, January 15, 1980.
9. Definition, Specification, and Analysis of Manual, Automatic and Supervisory Station Control and Data Acquisition, ANSI/IEEE C 37.1 - 1979, December 31, 1979.
10. A Study of the Costs of Alternative Communication Systems for Utility Distribution Automation, prepared by System Control Inc. for the Federal Communications Commission, Principal Investigator Michael F. Howard, February 1979.
11. Horstein, M. and Barnett, R., Satellite Solutions to Electric Utility Communications Needs, JPL Publication (to be published).