

# A PWM Plus Phase-Shift Control Bidirectional DC–DC Converter

Dehong Xu, *Member, IEEE*, Chuanhong Zhao, *Student Member, IEEE*, and Haifeng Fan

**Abstract**—A pulse-width modulation (PWM) plus phase-shift control bidirectional dc–dc converter is proposed. In this converter, PWM control and phase-shift control are combined to reduce current stress and conduction losses, and to expand ZVS range. The operation principle and analysis of the converter are explained, and ZVS condition is derived. A prototype of PWM plus phase-shift bidirectional dc–dc converter is built to verify the analysis.

**Index Terms**—Bidirectional dc–dc converter, conduction loss, phase-shift, pulse-width modulation.

## I. INTRODUCTION

**B**IDIRECTIONAL dc–dc converters will be widely used in applications such as dc uninterrupted power supplies, aerospace power systems, electric vehicles and battery chargers. In order to minimize the size and weight of the converters, switching frequency must be increased. But the increase of switching frequency results in higher switching losses. There are many techniques to solve this problem. Some circuits use resonant, quasiresonant, and/or multi-resonant techniques [1]–[3]. However, voltage or current stresses in these converters are higher and require the devices of higher VA rating. Some circuits use passive snubbers or active clamp techniques [4]. However, these converters become more complicated. Phase-shift ZVS technique has been used in bidirectional dc–dc converters since it can realize ZVS for all switches without auxiliary switches [5], [6]. However, when the amplitude of input voltage is not matched with that of output voltage, the current stresses and RMS currents of the converters become higher. In addition the converters can not achieve ZVS in light-load condition.

Fig. 1 is a phase-shift (PS) bidirectional dc–dc converter [7]. There are two switches on both sides of the isolation transformer. Switch  $M_1$  and  $M_2$  are controlled complementarily. Switch  $M_3$  and  $M_4$  are also controlled complementarily. Duty cycles of the switches are kept in 0.5. The inductor  $L_1$  is used as the main energy transfer element. Fig. 1 is simplified as Fig. 2(a). Fig. 3(a) shows the corresponding waveforms of the simplified circuit when the amplitude of equivalent input voltage ( $V_{ab}$ ) is equal to that of equivalent output voltage

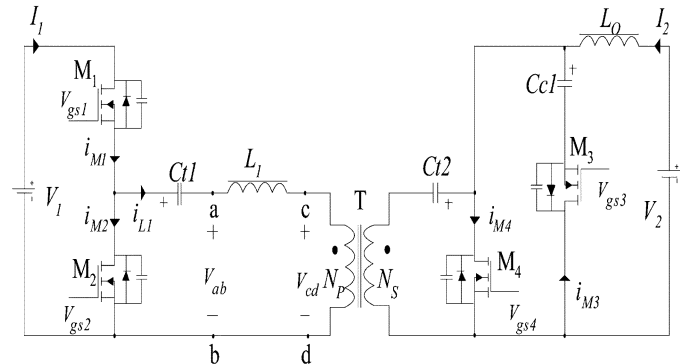

Fig. 1. Phase-shift bidirectional dc–dc converter.

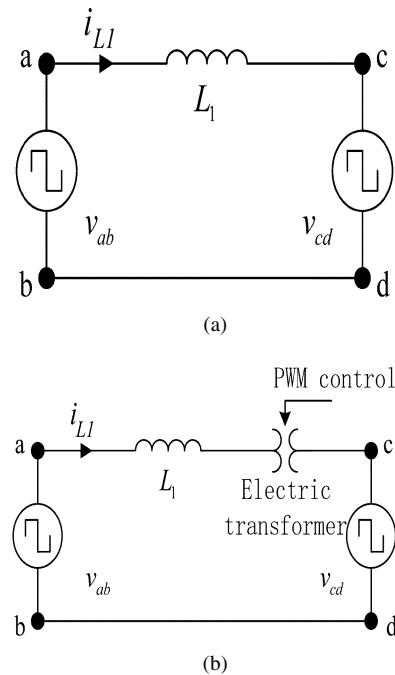

Fig. 2. (a) Simplified circuit of PS control. (b) Simplified circuit of PPS control.

Manuscript received December 10, 2002; revised October 6, 2003. This paper was presented at the APEC'03 Conference, Miami Beach, FL, February 2003. This work was supported by the Delta Power Electronics Science and Education Development Fund and the Foundation for University Key Teacher by Ministry of Education of China. Recommended by Associate Editor Y.-F. Liu.

The authors are with the Department of Electrical Engineering, Zhejiang University, Hangzhou 310027, China (e-mail: xdh@cee.zju.edu.cn).

Digital Object Identifier 10.1109/TPEL.2004.826485

( $V_{cd}$ ), that is  $V_1/2 = NV_2$ , where  $N = N_p/N_s$  is the turn ratio of the isolation transformer. When the amplitude of equivalent input voltage ( $V_{ab}$ ) is not equal to that of equivalent output voltage ( $V_{cd}$ ), such as  $V_1/2 < NV_2$ , Fig. 3(b) shows the corresponding waveforms. The current stresses and RMS

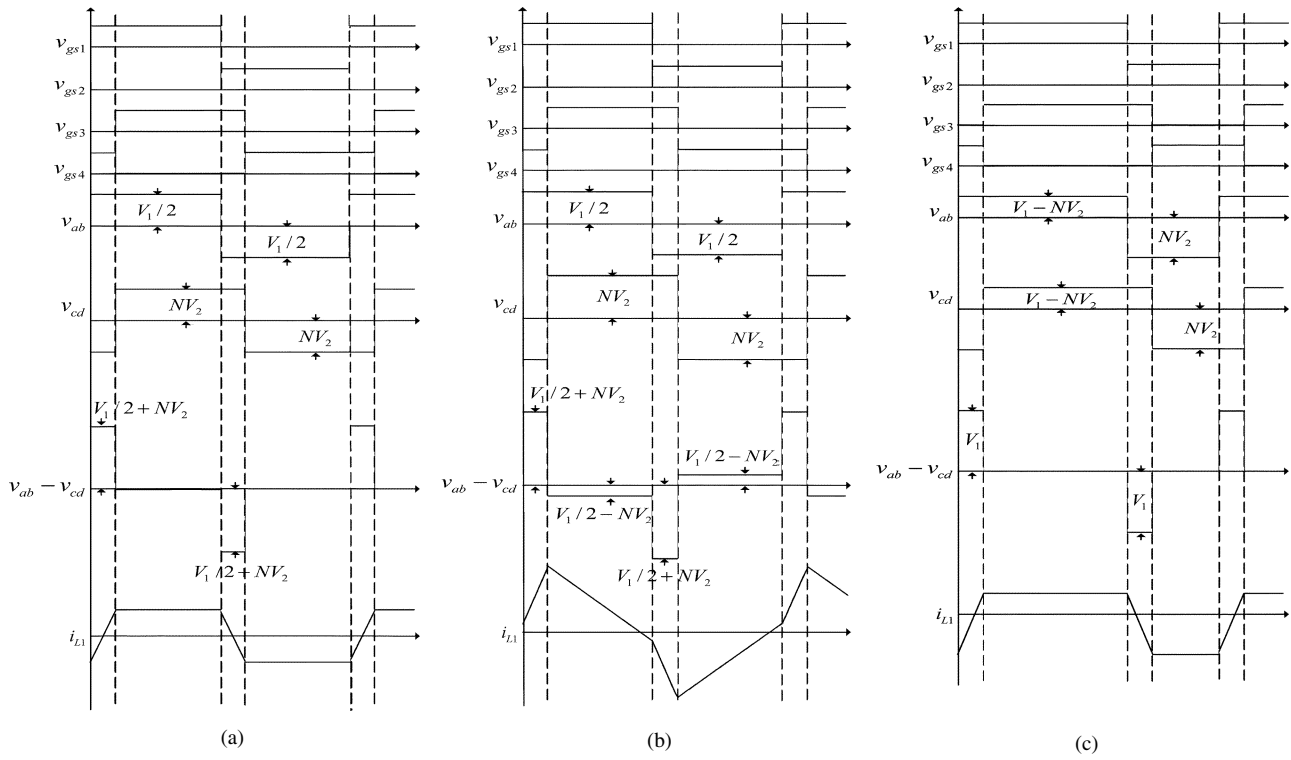

Fig. 3. (a) PS control when  $V_1/2 = NV_2$ . (b) PS control when  $V_1/2 = NV_2$ . (c) PPS control when  $V_1/2 = NV_2$ .

currents of the converter become much higher and the reactive power transferred also increases, which leads to higher current stresses of the switch devices and higher conduction losses. The converter can not achieve ZVS in light-load condition.

This paper proposes a PWM plus phase-shift (PPS) control bidirectional dc-dc converter. Fig. 2(b) shows concept of PPS control bidirectional dc-dc converter. The PWM control of duty cycles acts as an electric transformer between equivalent input voltage ( $V_{ab}$ ) and equivalent output voltage ( $V_{cd}$ ), so that both positive and negative amplitudes of equivalent input voltage ( $V_{ab}$ ) are equal to those of equivalent output voltage ( $V_{cd}$ ). Fig. 3(c) shows the corresponding waveforms of the simplified circuit of PPS control bidirectional dc-dc converter. Compared with PS control, PPS control can reduce the current stresses and RMS currents of the converter. The losses of the converter can also decrease. Later, it will be proved that the converter can achieve ZVS in larger load variation.

## II. OPERATION PRINCIPLE OF PPS CONTROL CONVERTER

To simplify the analysis, the operation of PPS control converter is explained with the following assumptions.

- 1) The converter has reached steady state.
- 2) All switch devices are assumed as ideal switches with parallel body diodes and parasitic capacitors.
- 3) The inductance  $L_1$  is composed of the leakage inductance of the transformer and additional series inductance.
- 4) The values of the capacitors  $C_{t1}$ ,  $C_{t2}$ , and  $C_{c1}$  are so large that the voltage ripples across them are small.

- 5) The resonant frequency of capacitor (composed of  $C_{t1}$ ,  $C_{t2}$ , and  $C_{c1}$ ) and  $L_1$  is much lower than the switching frequency of the converter.

Duty cycles of  $M_1$  and  $M_3$  are  $D$ , and duty cycles of  $M_2$  and  $M_4$  are  $1-D$ . In the forward mode, the gate drive signals of  $M_1$  and  $M_2$  is leading to those of  $M_3$  and  $M_4$  so that power flows from  $V_1$  to  $V_2$ . The equivalent circuits and key waveforms in the forward mode are shown in Figs. 4 and 5, respectively. The switching cycle can be divided into eight stages which are explained as follows.

1) *Stage 1* ( $t_0 - t_1$ ): Just before  $t_0$ ,  $M_4$  is turned off.  $M_1$  is on. The current  $i_{L1}$  is in positive direction. The capacitor in parallel with  $M_4$  is charged, while the capacitor in parallel with  $M_3$  is discharged. The voltage across  $M_3$  decreases to zero at  $t_0$  and  $M_3$ 's body diode starts to conduct.  $M_3$  is turned on with ZVS and then works as a synchronous rectifier. The voltage across  $M_4$  is clamped at  $V_{C_{c1}}$ . The current slopes of  $L_1$  is

$$\frac{di_{L1}}{dt} = \frac{V_1 - V_{C_{t1}} + NV_{C_{t2}} - NV_{C_{c1}}}{L_1} \quad (1)$$

where  $V_{C_{t1}}$ ,  $V_{C_{t2}}$ ,  $V_{C_{c1}}$  are average voltages of  $C_{t1}$ ,  $C_{t2}$ , and  $C_{c1}$ , respectively.

2) *Stage 2* ( $t_1 - t_2$ ):  $M_1$  is turned off at  $t_1$ . The capacitor in parallel with  $M_1$  is charged linearly by the current  $i_{L1}$  and the capacitor in parallel with  $M_2$  is discharged. The stage terminates at  $t_2$ , while the voltage across  $M_2$  is zero.

3) *Stage 3* ( $t_2 - t_3$ ):  $M_2$ 's body diode starts to conduct at  $t_2$ . Then  $M_2$  is turned on in zero-voltage condition. The current

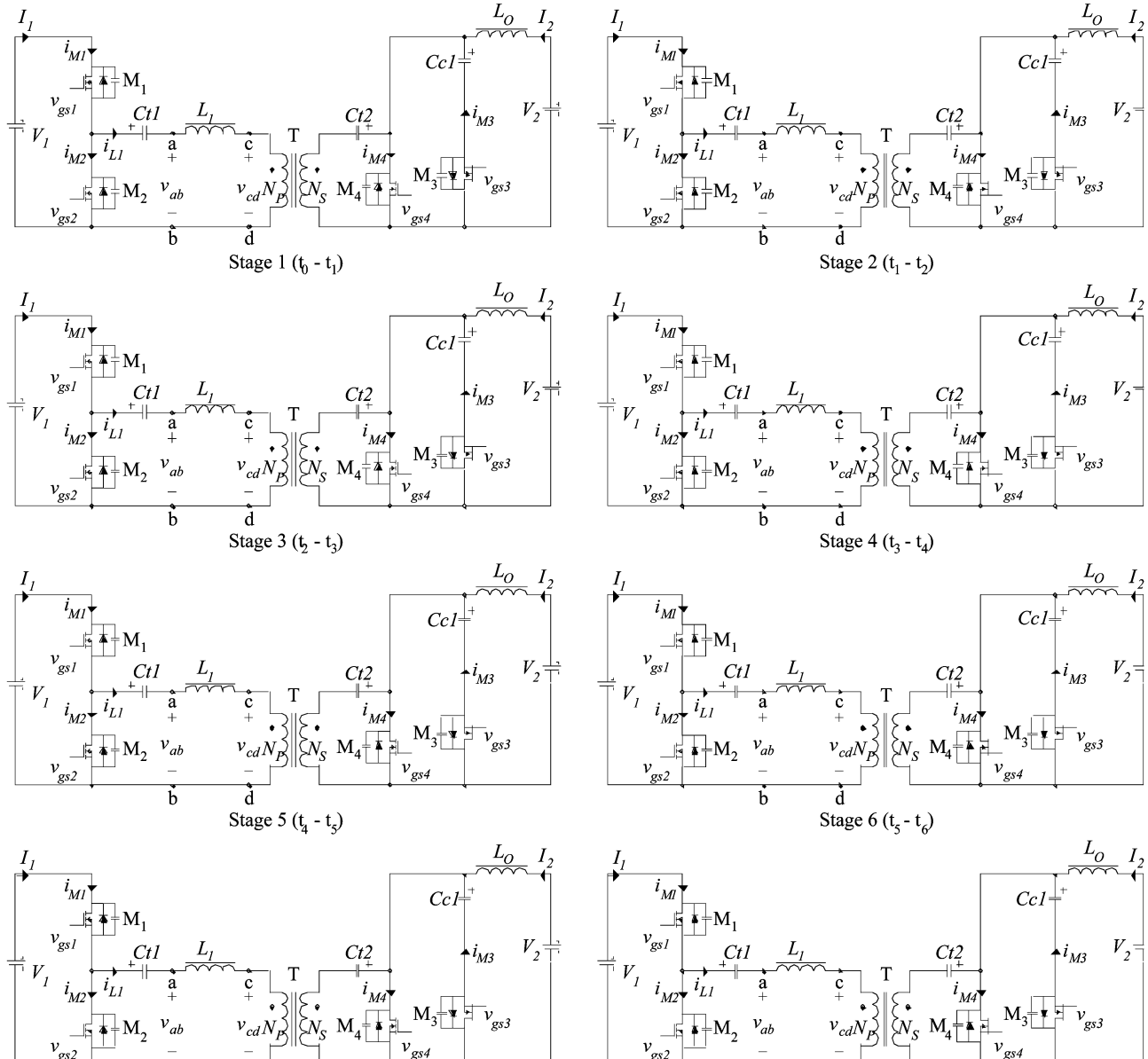

Fig. 4. Operation stages of the converter in the forward mode.

$i_{L1}$  decreases linearly and its direction is changed from positive to negative. The slope of  $i_{L1}$  is

$$\frac{di_{L1}}{dt} = \frac{-V_{Ct1} + NV_{Ct2} - NV_{Cc1}}{L_1}. \quad (2)$$

4) *Stage 4* ( $t_3 - t_4$ ): At  $t_3$ ,  $M_3$  is turned off. The capacitor in parallel with  $M_3$  is charged and the capacitor in parallel with  $M_4$  is discharged linearly. At the end of this stage, the voltage across  $M_4$  decreases to zero.

5) *Stage 5* ( $t_4 - t_5$ ): The body diode of  $M_4$  is conducting at the beginning of this stage. Therefore  $M_4$  is turned on in zero-voltage condition. The slope of  $i_{L1}$  is

$$\frac{di_{L1}}{dt} = \frac{-V_{Ct1} + NV_{Ct2}}{L_1}. \quad (3)$$

6) *Stage 6* ( $t_5 - t_6$ ): At  $t_5$ ,  $M_2$  is turned off. The capacitor in parallel with  $M_2$  is charged and the capacitor in parallel with  $M_1$  is discharged linearly. At the end of this stage, the voltage across  $M_1$  goes down to zero.

7) *Stage 7* ( $t_6 - t_7$ ): At the beginning of this stage, the body diode of  $M_1$  is conducting and  $M_1$  is turned on in zero-voltage condition. The slope of  $i_{L1}$  is

$$\frac{di_{L1}}{dt} = \frac{V_1 - V_{Ct1} + NV_{Ct2}}{L_1}. \quad (4)$$

8) *Stage 8* ( $t_7 - t_8$ ): At  $t_7$ ,  $M_4$  is turned off. The capacitor in parallel with  $M_4$  is charged and the capacitor in parallel with  $M_3$  is discharged linearly until the voltage across  $M_3$  reaches zero. After  $t_8$ , the next switching cycle starts again.

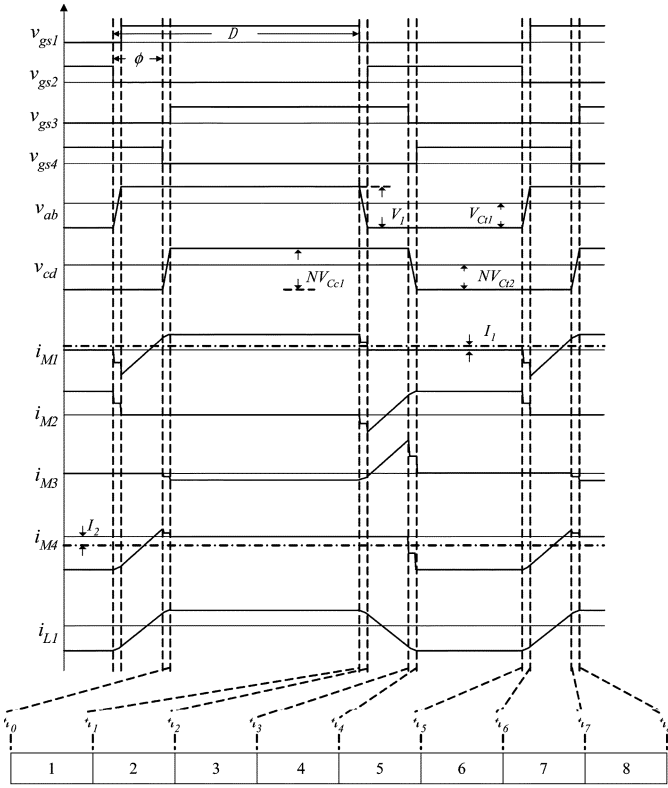

Fig. 5. Steady-state waveforms of the converter in the forward mode.

On the contrary, in the backward mode, the gate drive signals of  $M_3$  and  $M_4$  are leading to those of  $M_1$  and  $M_2$ . The equivalent circuits and key waveforms in the backward mode are shown in Figs. 6 and 7, respectively. The switching cycle can also be divided into 8 stages. The principle of operation of the backward mode (power flows from  $V_2$  to  $V_1$ ) is similar to that of the forward mode, so it will not be explained in this paper.

### III. ANALYSIS OF CONVERTER

#### A. Low-Frequency Average Model

We use  $2\pi$  to represent one switching cycle.  $\phi$  is the phase shift between two cells, which are connected by the transformer.  $\phi$  is defined to be positive when  $V_{gs1}$  is leading to  $V_{gs3}$  in phase. The duty cycles of  $M_1$  and  $M_3$  are  $D$ , and duty cycles of  $M_2$  and  $M_4$  are  $1-D$ .

PWM control is used to regulate the positive amplitude of equivalent input voltage to be equal to that of equivalent output voltage and at the same time the negative amplitude of equivalent input voltage is regulated to be equal to that of equivalent output voltage. Hence the slope of the current  $i_{L1}$  is zero in stage 1 and stage 5. In other words, the duty cycles of  $M_1$  and  $M_3$  are

$$D = \frac{NV_2}{V_1}. \quad (5)$$

Referring to the Appendix A, the power flows from  $V_1$  to  $V_2$  under PPS control

$$P = \frac{\phi NT}{8\pi^2 L_1} (-|\phi|V_1^2 - 4\pi V_2^2 N^2 + 4\pi V_1 V_2 N) \quad (6)$$

where  $T$  is operation period.

Referring to the Appendix B, the current stress of inductor  $L_1$  under PPS control

$$I_{L1 \max} = \max\{|i_{L1}|, |i_{L3}|\} = \max\left\{\frac{V_1 - NV_2}{V_1^2 L_1} A, \frac{NV_2}{V_1^2 L_1} A\right\} \quad (7)$$

where  $A = \frac{TV_1 NV_2 - TN^2 V_2^2}{\sqrt{T(TV_1^2 N^2 V_2^2 - 2TV_1 N^3 V_2^3 + TN^4 V_2^4 - 2V_1^2 PL_1)}}$ .

The power flows from  $V_1$  to  $V_2$  under PS control [7]

$$P = \frac{\phi NT V_1 V_2}{4\pi^2 L_1} (\pi - |\phi|). \quad (8)$$

The current stress of inductor  $L_1$  under PS control [7]

$$I_{L1 \max} = \max\left\{\frac{TV_1^2 - 2\sqrt{TV_1 NV_2(TV_1 NV_2 - 16PL_1)}}{8V_1 L_1}, \frac{2TN^2 V_2^2 - \sqrt{TV_1 NV_2(TV_1 NV_2 - 16PL_1)}}{8NV_2 L_1}\right\}. \quad (9)$$

#### B. Current Stress Comparison

Fig. 8 shows current stress of inductor  $L_1$  under PS control in the following conditions:  $V_1 = 48$  Vdc,  $V_2 = 20$  Vdc–30 Vdc,  $Np:Ns = 1:1$ ,  $P = 100$  W, switching frequency  $f = 100$  kHz, inductance  $L_1 = 1 \mu\text{H}$ – $6 \mu\text{H}$ . From Fig. 8 we can see that the smaller the value of inductance  $L_1$  is, the lower current stress is when output voltage is 24 V. In other words, input voltage and output voltage match. On the contrary, when input voltage and output voltage do not match, such as output voltage is 30 V, the smaller the value of inductance  $L_1$  is, the higher current stress is. It is difficult to design the value of inductance  $L_1$  when two aspects above are considered.

Here a method to optimize the value of inductance  $L_1$  is proposed. Current stress  $I_{L1 \max}$  is averaged within the range of output voltage. Average current stress  $I_{AV}$  is used to determine the value of inductance  $L_1$

$$I_{AV} = \frac{\int_{V_{2 \min}}^{V_{2 \max}} I_{L1 \max} dV_2}{V_{2 \max} - V_{2 \min}}. \quad (10)$$

The variation of average current stress under PS control,  $I_{AV}$ , as a function of value of inductance  $L_1$  is plotted in Fig. 9(a) from which we can find that average current stress  $I_{AV}$  is minimum when the value of inductance is  $4.4 \mu\text{H}$ . Fig. 9(b) shows average current stress under PPS control versus value of inductance  $L_1$ . But we are hardly to find the minimum average current stress since the smaller value of inductance is, the lower

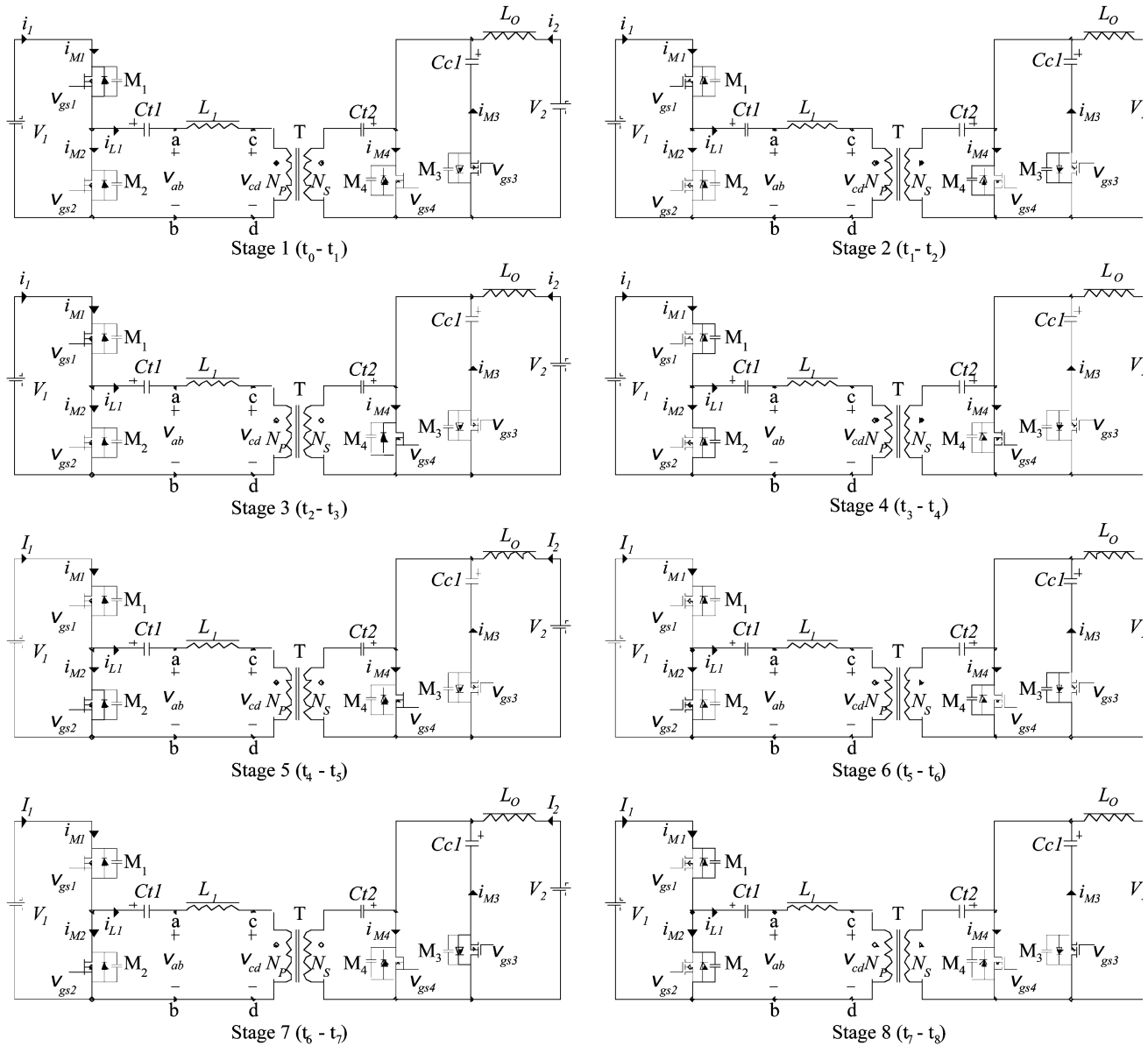

Fig. 6. Operation stages of the converter in the backward mode.

average current stress is. But the smaller value of inductance  $L_1$  is, the smaller the phase-shift angle is, and the more difficult the converter is, is controlled. Here we assume the minimum phase-shift angle is  $20^\circ$ . Value of inductance  $L_1$  under PPS control is given in previous conditions

$$L_1 = \frac{V_1^2 T}{81P} = \frac{48 \times 48 \times \frac{1}{100000}}{81 \times 100} = 2.844 \mu\text{H}. \quad (11)$$

Fig. 10(a) shows current stress of inductor  $L_1$  under PS control and under PPS control in the following conditions:  $V_1 = 48$  Vdc,  $V_2 = 20$  Vdc–30 Vdc,  $Np:Ns = 1:1$ ,  $P = 100$  W, switching frequency  $f = 100$  kHz, inductance  $L_1 = 1 \mu\text{H}$ – $6 \mu\text{H}$ . From it we can see that PPS

control can reduce current stress except that the value of the inductance  $L_1$  is large enough.

Pspice simulation results and calculation results derived from (7) under PPS control, Pspice simulation results and calculation results derived from (9) under PS control are compared in Fig. 10(b). From it we can see that the Pspice simulation traces and calculation results are in a good agreement, PPS control can reduce current stress.

### C. ZVS Range Comparison

The ZVS range under PS control is [7]

$$|\phi| > \max \left( \frac{\pi}{2} - \frac{\pi V_1}{4NV_2}, \frac{\pi}{2} \sqrt{2 - 4 \frac{NV_2}{V_1}} \right). \quad (12)$$

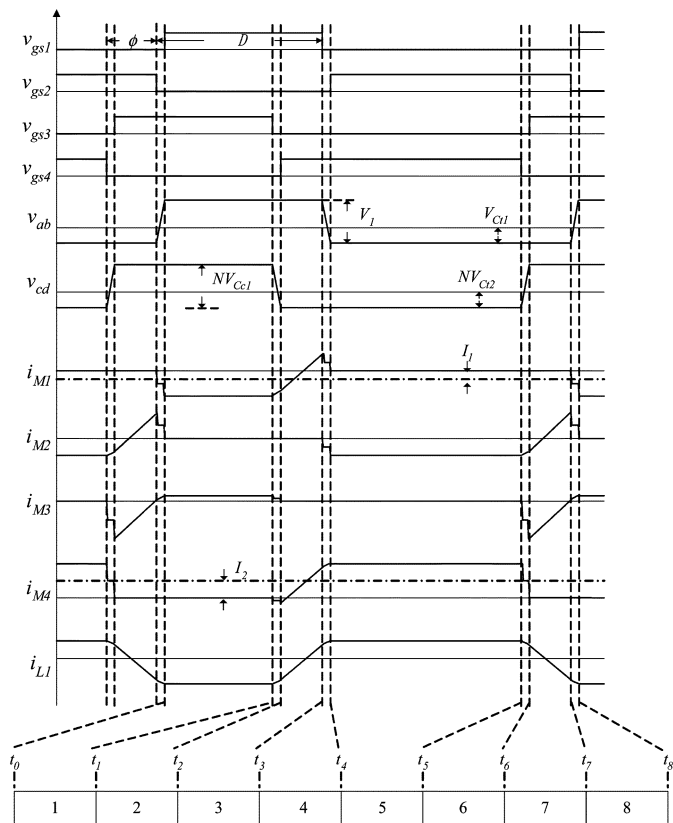

Fig. 7. Steady-state waveforms of the converter in the backward mode.

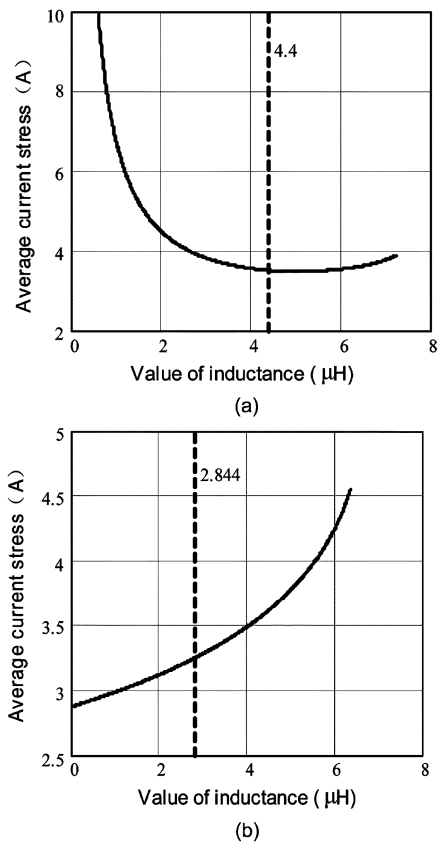

Fig. 9. Average current stress versus value of inductance  $L_1$ . (a) PS control. (b) PPS control.

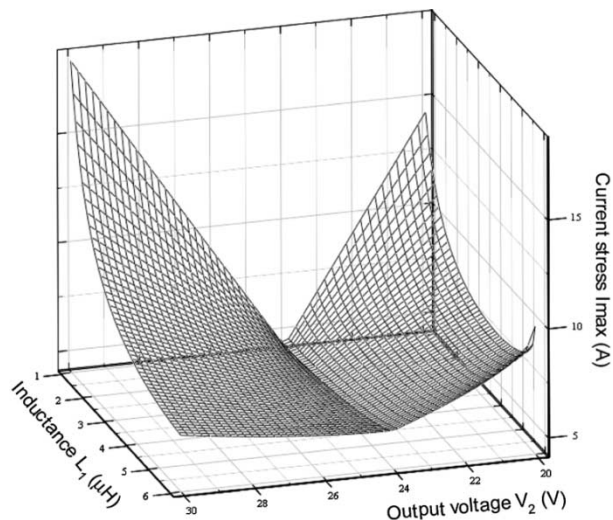

Fig. 8. Current stress versus output voltage and inductance  $L_1$  under PS control.

Fig. 11 shows ZVS range under PS control.

Referring to the Appendix C, the ZVS range under PPS control is

$$|\phi| > 0. \tag{13}$$

In other words, the converter under PPS control can maintain ZVS in larger load variation. Hence PPS control can expand ZVS range.

#### IV. EXPERIMENTAL RESULTS

Fig. 12 shows the system block diagram of the proposed converter. UC3875 generates signal g1 and signal g2. Signal g1 has leading phase according to the error signal of command power ( $P_o^*$ ) and actual power ( $P_o$ ) to signal g2. Signal g1 and signal g2 connect to UC3525 respectively. Signal g1 has the same phase as  $v_{gs1}$  and signal g2 has the same phase as  $v_{gs3}$ . The signal  $NV_2/V_1$  modulates the duty cycles of  $v_{gs1}$  and  $v_{gs3}$ . By inverting  $v_{gs1}$  and  $v_{gs3}$ , we can get other two gate signals.

A prototype of PPS control bidirectional dc-dc converter is built to verify the analysis. Experiments are performed in the following conditions:  $V_1 = 48$  Vdc,  $V_2 = 24$  Vdc-30 Vdc,  $Np:Ns = 1:1$ ,  $L_0 = 150$   $\mu$ H,  $Ct1 = Ct2 = 13$   $\mu$ F,  $Cc1 = 2.2$   $\mu$ F,  $L_1 = 4.4$   $\mu$ H (PS control),  $L_1 = 2.8$   $\mu$ H (PPS control), switching frequency  $f = 100$  kHz,  $M_1-M_4$ : MOSFET IRF540 (IR) (referring to Appendix D).

Fig. 13 shows experimental waveforms in  $V_2 = 24$  Vdc with 100 W output power condition. Since input voltage  $V_1$  and output voltage  $V_2$  match in this case, current stress of inductance  $L_1$  between PS control and PPS control is the same.

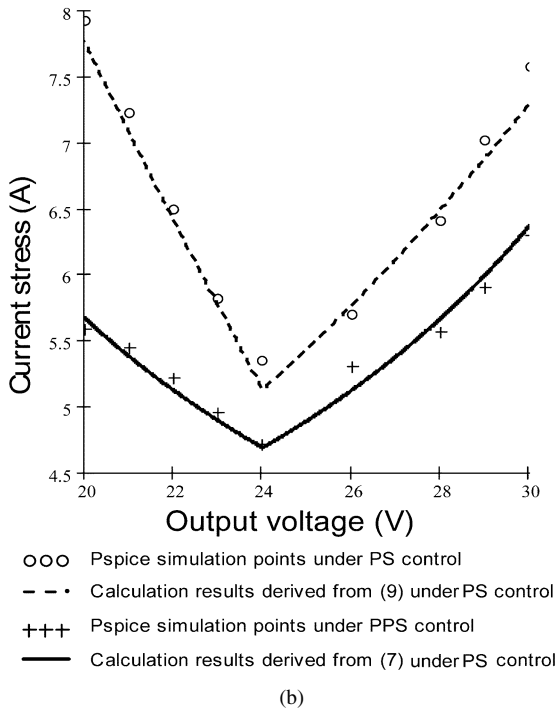
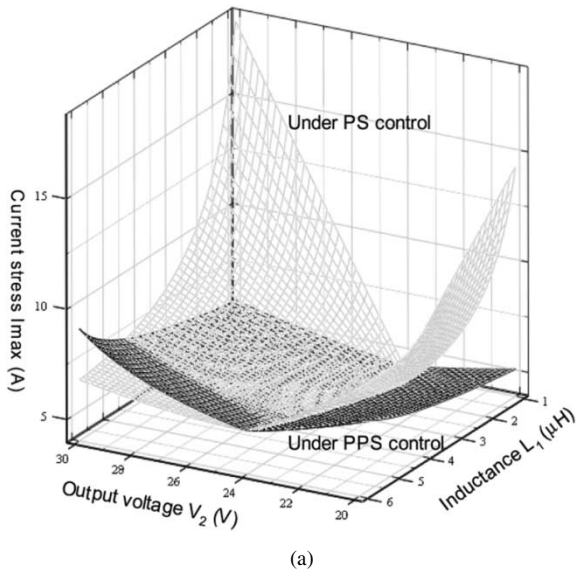

Fig. 10. (a) Current stress versus output voltage and inductance  $L_1$  under PS control and under PPS control. (b) Current stress versus output voltage.

Fig. 14 shows experimental waveforms in  $V_2 = 30$  Vdc with 100 W output power condition. In this case, input voltage  $V_1$  and output voltage  $V_2$  do not match. Therefore, current stress of inductor  $L_1$  with PS control is higher than that of PPS control. Fig. 15 gives curves of current stress versus output voltage under PS and PPS control respectively. From the experimental waveforms and curves, we can easily see that PPS control can reduce current stress and reduce conduction losses.

Fig. 16 shows experimental waveforms in  $V_2 = 30$  Vdc with 30 W output power condition. The converter under PS control can not achieve ZVS, while the converter under PPS control

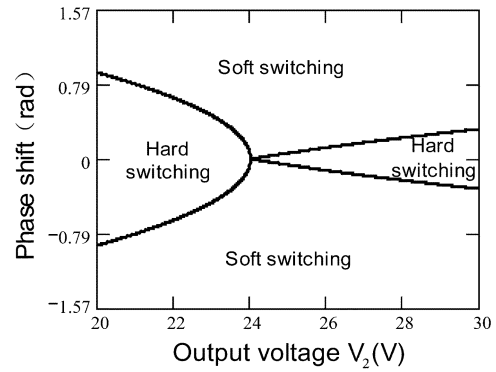

Fig. 11. ZVS range versus output voltage under PS control.

can still hold ZVS. Therefore, PPS control can reduce switching losses.

Fig. 17 shows the efficiency curves of the converter under PS and PPS control. It can be easily found that PPS control has higher efficiency than PS control, especially in light-load condition.

## V. CONCLUSION

A PWM plus phase-shift control bidirectional dc-dc converter is proposed in this paper. From the theoretical analysis and the experiments, it can be found that PPS control has the following features.

- 1) PPS control reduces current stress, conduction losses and switching losses of devices.
- 2) The converter under PPS control can achieve ZVS in a larger load variation.

## APPENDIX A

From Fig. 5, we can see that average voltage of inductance  $L_1$  in one period is zero

$$DV_1 - V_{Ct1} + NV_{Ct2} - DNV_{Ct1} = 0. \quad (A1)$$

Average voltage of inductance  $L_M$  in one period is also zero

$$-V_{Ct2} + DV_{Ct1} = 0. \quad (A2)$$

Average voltage of output inductance  $L_o$  in one period is zero too

$$DV_{Ct1} - V_2 = 0. \quad (A3)$$

Average current of capacitance  $Cc1$  in one period is zero

$$4\pi D\phi TN(V_{Ct1} - NV_{Ct2} + NV_{Ct1} - V_1) + 8\pi^2 L_1(DI_2 - NI_1) + \phi^2 TN(-NV_{Ct1} + V_1) = 0. \quad (A4)$$

According to the law of conservation of energy, the following equation is obtained:

$$V_1 I_1 + V_2 I_2 = 0. \quad (A5)$$

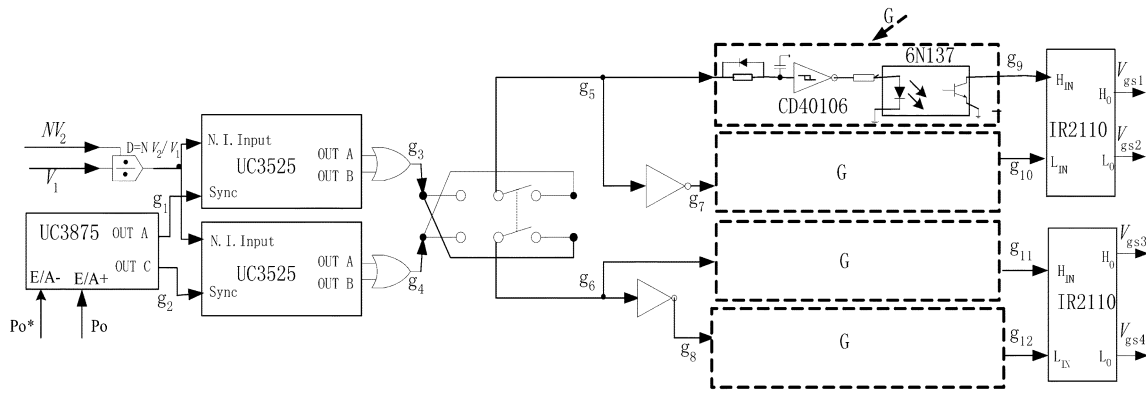

Fig. 12. System block diagram of the proposed converter.

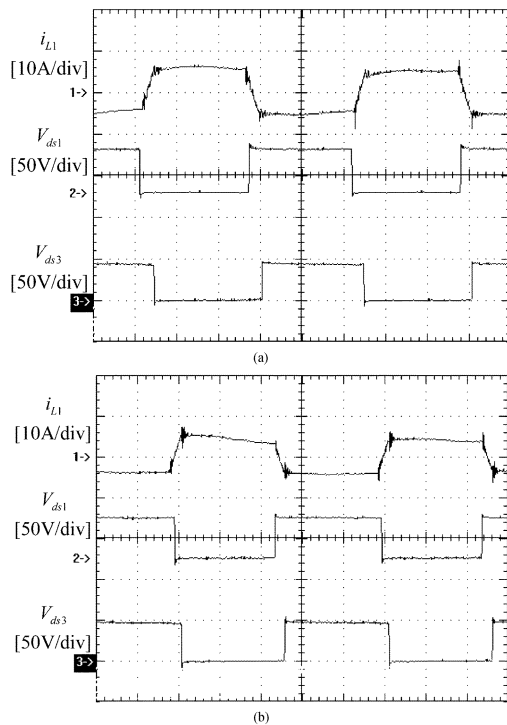

Fig. 13. Experimental waveforms in  $V_2 = 24$  Vdc (100 W-output) condition (2 us/div). (a) PS control. (b) PPS control.

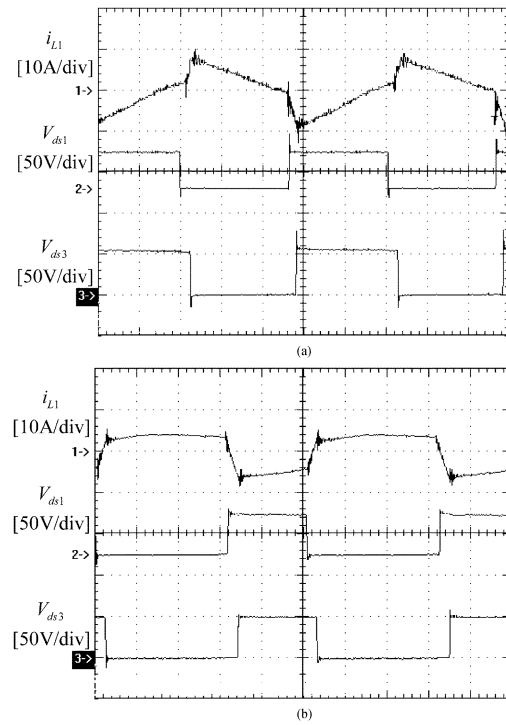

Fig. 14. Experimental waveforms in  $V_2 = 30$  Vdc (100 W-output) condition (2 us/div). (a) PS control. (b) PPS control.

The output current of the converter in bidirectional operation can be obtained as following:

$$I_2 = \frac{\phi NT}{8\pi^2 L_1 V_2} (-|\phi|V_1^2 - 4\pi V_2^2 N^2 + 4\pi V_1 V_2 N). \quad (A6)$$

In bidirectional operation, the power transmitted through the converter can be expressed by

$$P = V_2 I_2 = \frac{\phi NT}{8\pi^2 L_1} (-|\phi|V_1^2 - 4\pi V_2^2 N^2 + 4\pi V_1 V_2 N). \quad (A7)$$

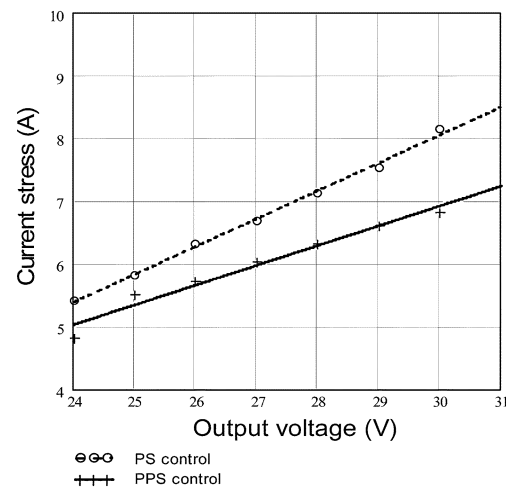

(A7) Fig. 15. Experimental result of current stress versus output voltage.



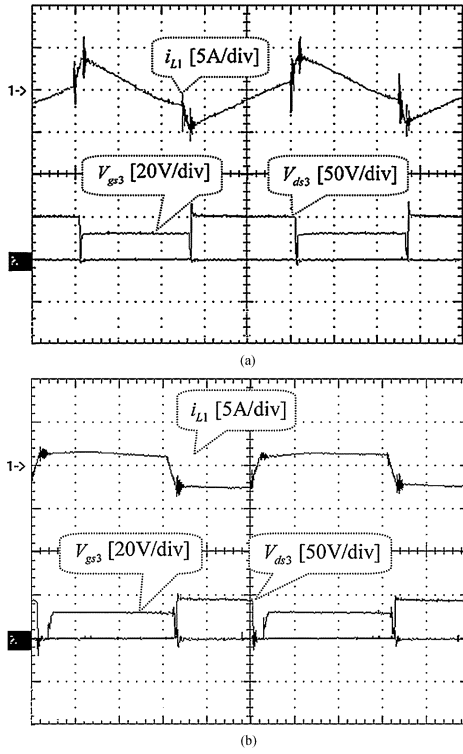

Fig. 16. Experimental waveforms in  $V_2 = 30$  Vdc (30 W-output) condition (2 us/div). (a) PS control. (b) PPS control.

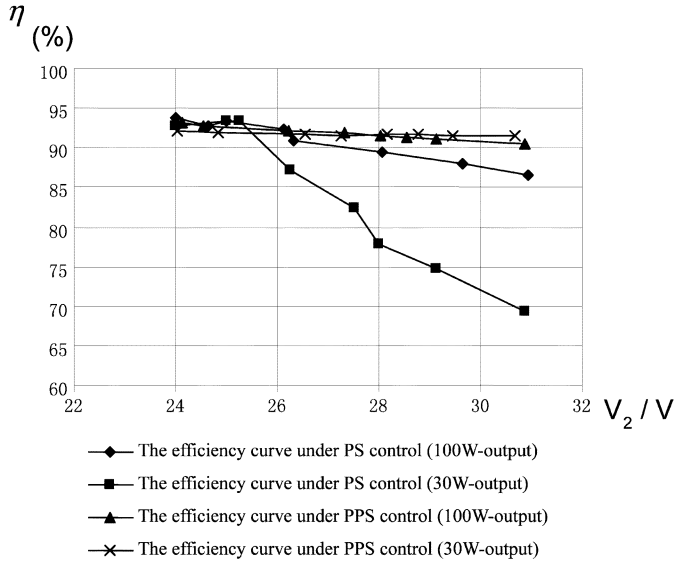

Fig. 17. Efficiency waveforms versus output voltage.

#### APPENDIX B

$i_{L1}$ ,  $i_{L3}$ ,  $i_{L5}$ , and  $i_{L7}$  are the currents of inductance  $L_1$  at  $t_1$ ,  $t_3$ ,  $t_5$ , and  $t_7$ .

We can derive the following equation from (1):

$$\frac{i_{L11} - i_{L17}}{(D - \phi/2\pi)T} = \frac{V_1 - V_{Ct1} + NV_{Ct2} - NV_{Ct1}}{L_1}. \quad (\text{B1})$$

We can derive the following equation from (2):

$$\frac{i_{L13} - i_{L11}}{T\phi/2\pi} = \frac{-V_{Ct1} + NV_{Ct2} - NV_{Ct1}}{L_1}. \quad (\text{B2})$$

We can derive the following equation from (3):

$$\frac{i_{L15} - i_{L13}}{(1 - D - \phi/2\pi)T} = \frac{-V_{Ct1} + NV_{Ct2}}{L_1}. \quad (\text{B3})$$

Average current of inductance  $L_1$  in one period is zero

$$\begin{aligned} \frac{i_{L11} + i_{L13}}{2} \frac{\phi}{2\pi} + \frac{i_{L13} + i_{L15}}{2} \left(1 - \frac{\phi}{2\pi} - D\right) \\ + \frac{i_{L15} + i_{L17}}{2} \frac{\phi}{2\pi} + \frac{i_{L17} + i_{L11}}{2} \left(D - \frac{\phi}{2\pi}\right) = 0. \end{aligned} \quad (\text{B4})$$

$i_{L1}$ ,  $i_{L3}$ ,  $i_{L5}$ , and  $i_{L7}$  can be obtained by combining (B1)–(B4)

$$i_{L1} = i_{L7} = \frac{V_1 - NV_2}{2\pi L_1} T\phi, \quad i_{L3} = i_{L5} = -\frac{NV_2}{2\pi L_1} T\phi. \quad (\text{B5})$$

Equation (7) can be obtained by combining (A7) and (B5).

#### APPENDIX C

In the forward mode, the converter can achieve ZVS on condition of

$$i_{L5} < 0 \quad (M_1 \text{ can be turned on with ZVS}) \quad (\text{C1})$$

$$i_{L1} > 0 \quad (M_2 \text{ can be turned on with ZVS}) \quad (\text{C2})$$

$$-Ni_{L13} + I_2 > 0 \quad (M_3 \text{ can be turned on with ZVS}) \quad (\text{C3})$$

$$Ni_{L17} - I_2 > 0 \quad (M_4 \text{ can be turned on with ZVS}). \quad (\text{C4})$$

The ZVS range under PPS control can be obtained by substituting (B5) into (C1)–(C4)

$$|\phi| > 0. \quad (\text{C5})$$

#### APPENDIX D

The design of PPS control bidirectional dc–dc converter is illustrated on the prototype built for the following specifications: input voltage rating: 48 Vdc, output voltage rating: 24 Vdc, and it varies from 24 Vdc to 30 Vdc, maximum output power: 100-W, switching frequency: 100 kHz.

In order that duty cycles of M1 and M3 are 0.5 when input voltage and output voltage are equal to their rating value respectively, the turn ratio of the transformer can be derived from (5): 1:1.

In order to simplify the prototype, the same type of MOSFET is chosen. From (7) and (9), the current stress of  $M_1$ – $M_4$  can

be calculated and it is 7.3 A. The voltage stress of  $M_1-M_4$  is 60 Vdc when the converter is operated under PS control and the output voltage is 30 Vdc. Therefore, *IRF540* whose  $V_{DSS}$  is 100 Vdc and  $I_D$  is 28 A can satisfy this situation.

The value of the output inductance  $L_o$  can be calculated by  $L_o = (TV_{2\max})/(4\Delta I_{\max})$  ( $\Delta I_{\max}$  is the maximum ripple of the output current, here it is 0.5 A) and it is 150  $\mu$ H.

The value of  $Ct1$ ,  $Ct2$ , and  $Cc1$  can be calculated by  $C = (\int idt)/(\Delta U_{\max})$  ( $\Delta U_{\max}$  is the maximum ripple of the voltage, here it is 1 V) and  $Ct1 = Ct2 = 13 \mu$ F,  $Cc1 = 2.2 \mu$ F.

## REFERENCES

- [1] M. Jain, P. K. Jain, and M. Daniele, "Analysis of a bidirectional dc-dc converter topology for low power application," in *IEEE Proc. CCECE'97 Conference*, 1997, pp. 548-551.
- [2] K. Venkatesan, "Current mode controlled bidirectional flyback converter," in *Proc. IEEE PESC'89 Conference*, 1989, pp. 835-842.
- [3] B. Ray, "Bidirectional dc/dc power conversion using constant-frequency quasiresonant topology," in *Proc. ISCAS'93 Conference*, 1993, pp. 347-350.
- [4] K. Wang, C. Y. Lin, L. Zhu, D. Qu, F. C. Lee, and J. S. Lai, "Bi-directional dc to dc converters for fuel cell systems," *IEEE Trans. Power Electron.*, vol. 13, pp. 47-51, Jan. 1998.
- [5] R. W. DeDoncker, D. M. Divan, and M. H. Kheraluwala, "Power conversion apparatus for dc/dc conversion using dual active bridges," U.S. Patent 5 027 264, 1991.
- [6] M. H. Kheraluwala and R. W. Gascoigne, "Performance characterization of a high-power dual active bridge dc-to-dc converter," *IEEE Trans. Ind. Applicat.*, vol. IA-28, pp. 1294-1301, Nov./Dec. 1992.
- [7] G. Chen, D. Xu, Y. Wang, and Y.-S. Lee, "A new family of soft-switching phase-shifted bidirectional dc-dc converters," in *Proc. IEEE PESC'01 Conference*, pp. 859-865.



**Dehong Xu** (M'94) was born in Hangzhou, China, in 1961. He received the B.S., M.S., and Ph.D. degrees from the Department of Electrical Engineering, Zhejiang University, China, in 1983, 1986, and 1989, respectively.

Since 1989, he has been a faculty member at Zhejiang University, where he is currently a Professor in the Department of Electrical Engineering. He was a Visiting Professor in the Department of Electrical Engineering, University of Tokyo, Tokyo, Japan, from May 1995 to June 1996, and at the Center of Power Electronics System, Virginia Polytechnic Institute and State University (Virginia Tech), Blacksburg, from June to December 2000. His research interests include application of advanced control in power electronics, high-frequency conversion, and power quality.

Dr. Xu is a Vice Chairman of the Chinese Power Supply Society and the Chinese Power Electronics Society.



**Chuanhong Zhao** (S'03) was born in China in 1977. She received the B.S. and M.S. degrees in electrical engineering from Zhejiang University, Hangzhou, China, in 2000 and 2003, respectively, and is currently pursuing the Ph.D. degree in power electronic systems in the Department of Information Technology and Electrical Engineering, Swiss Federal Institute of Technology (ETH), Zurich, Switzerland.

Her research fields of interest include bidirectional converters, control of Matrix converters, and soft

switching technique.



**Haifeng Fan** was born in China in 1978. He received the B.S. degree in electrical engineering from the Huazhong University of Science and Technology, Wuhan, China, in 2001 and is currently pursuing the M.S. degree in electrical engineering at Zhejiang University, Hangzhou, China.

His research interests include topology of bidirectional dc-dc converter and its control.