

A Review of Cell Equalization Methods for Lithium Ion and Lithium Polymer Battery Systems

Stephen W. Moore
Delphi Automotive Systems

Peter J. Schneider
Delphi Automotive Systems

Copyright © 2001 Society of Automotive Engineers, Inc.

ABSTRACT

Lithium-based battery technology offers performance advantages over traditional battery technologies at the cost of increased monitoring and controls overhead. Multiple-cell Lead-Acid battery packs can be equalized by a controlled overcharge, eliminating the need to periodically adjust individual cells to match the rest of the pack. Lithium-based batteries cannot be equalized by an overcharge, so alternative methods are required. This paper discusses several cell-balancing methodologies. Active cell balancing methods remove charge from one or more high cells and deliver the charge to one or more low cells. Dissipative techniques find the high cells in the pack, and remove excess energy through a resistive element until their charges match the low cells. This paper presents the theory of charge balancing techniques and the advantages and disadvantages of the presented methods.

INTRODUCTION

Lithium Ion and Lithium Polymer battery chemistries cannot be overcharged without damaging active materials [1-5]. The electrolyte breakdown voltage is precariously close to the fully charged terminal voltage, typically in the range of 4.1 to 4.3 volts/cell. Therefore, careful monitoring and controls must be implemented to avoid any single cell from experiencing an overvoltage due to excessive charging.

Single lithium-based cells require monitoring so that cell voltage does not exceed predefined limits of the chemistry. Series connected lithium cells pose a more complex problem: each cell in the string must be monitored and controlled. Even though the pack voltage may appear to be within acceptable limits, one cell of the series string may be experiencing damaging voltage due to cell-to-cell imbalances.

Traditionally, cell-to-cell imbalances in lead-acid batteries have been solved by controlled overcharging [6,7]. Lead-acid batteries can be brought into overcharge conditions without permanent cell damage, as the excess energy is released by gassing. This gassing mechanism is the natural method for balancing a series string of lead acid battery cells. Other chemistries, such as NiMH, exhibit similar natural cell-to-cell balancing mechanisms [8].

Because a Lithium battery cannot be overcharged, there is no natural mechanism for cell equalization. Therefore, an alternative method must be employed. This paper discusses three categories of cell balancing methodologies: charging methods, active methods, and passive methods.

Cell balancing is necessary for highly transient lithium battery applications, especially those applications where charging occurs frequently, such as regenerative braking in electric vehicle (EV) or hybrid electric vehicle (HEV) applications. Regenerative braking can cause problems for Lithium Ion batteries because the instantaneous regenerative braking current inrush can cause battery voltage to increase suddenly, possibly over the electrolyte breakdown threshold voltage.

Deviations in cell behaviors generally occur because of two phenomenon: changes in internal impedance or cell capacity reduction due to aging. In either case, if one cell in a battery pack experiences deviant cell behavior, that cell becomes a likely candidate to overvoltage during high power charging events. Cells with reduced capacity or high internal impedance tend to have large voltage swings when charging and discharging. For HEV applications, it is necessary to cell balance lithium chemistry because of this overvoltage potential.

For EV applications, cell balancing is desirable to obtain maximum usable capacity from the battery pack. During charging, an out-of-balance cell may prematurely approach the end-of-charge voltage (typically 4.1 to 4.3

volts/cell) and trigger the charger to turn off. Cell balancing is useful to control the higher voltage cells until the rest of the cells can catch up. In this way, the charger is not turned off until the cells simultaneously reach the end-of-charge voltage.

END-OF-CHARGE CELL BALANCING METHODS

Typically, cell-balancing methods employed during and at end-of-charging are useful only for electric vehicle purposes. This is because electric vehicle batteries are generally fully charged between each use cycle. Hybrid electric vehicle batteries may or may not be maintained fully charged, resulting in unpredictable end-of-charge conditions to enact the balancing mechanism.

Hybrid vehicle batteries also require both high power charge (regenerative braking) and discharge (launch assist or boost) capabilities. For this reason, their batteries are usually maintained at a SOC that can discharge the required power but still have enough headroom to accept the necessary regenerative power. To fully charge the HEV battery for cell balancing would diminish charge acceptance capability (regenerative braking).

CHARGE SHUNTING

The charge-shunting cell balancing method selectively shunts the charging current around each cell as they become fully charged (Figure 1). This method is most efficiently employed on systems with known charge rates. The shunt resistor R is sized to shunt exactly the charging current I when the fully charged cell voltage V is reached. If the charging current decreases, resistor R will discharge the shunted cell. To avoid extremely large power dissipations due to R , this method is best used with stepped-current chargers with a small end-of-charge current.

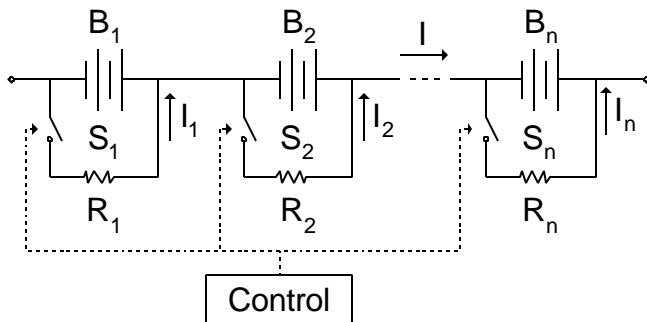

Figure 1. Charge Shunting

Disadvantages of the charge shunting method are the requirement for large power dissipating resistors, high current switches, and thermal management requirements. This method is best suited for systems that are charged often with small charge currents.

ACTIVE CELL BALANCING METHODS

Active cell balancing methods employ an active charge-shuttling element or voltage or current converters to move energy from one cell to another. These devices can be either analog or digitally controlled. The two major classifications of active cell balancing methods are charge shuttling and energy converting.

CHARGE SHUTTLING

Charge shuttling cell balancing mechanisms consist of a device that removes charge from a selected cell, stores that charge, and then delivers it to another cell. There are several embodiments of charge shuttling schemes, the most notable being a 'flying capacitor' (Figure 2).

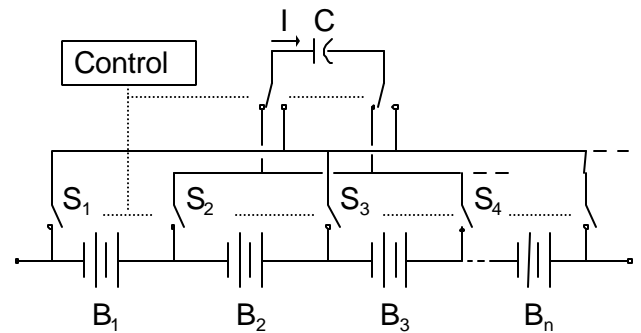

Figure 2. Flying Capacitor Charge Shuttling Method

The control electronics close the proper switches to charge capacitor C across cell B_1 . Once the capacitor is charged, the switches are opened. The switches are then closed to connect capacitor C across cell B_2 . The capacitor then delivers charge to B_2 based on the differential of voltage between B_1 and B_2 (Eq.1).

$$Charge ? \frac{1}{2} CV_{B_1}^2 ? \frac{1}{2} CV_{B_2}^2$$

The capacitor is then connected in the same manner across $B_3, B_4, \dots, B_n, B_1, \dots$. The highest charged cells will charge C and the lowest charged cells will take charge from C . In this way, the charge of the most charged cells are distributed to the least charged cells. The only electronic controls needed for this method is a fixed switching sequence to open and close the proper switches.

A variation on the 'flying capacitor' method is intelligently select which cells to balance. In this way, the capacitor can be charged from the highest cell and selectively discharged to the lowest cell. This method can dramatically reduce the time to charge balance the cells, especially if the highest and lowest charged cells are on the opposite ends of the pack. Additional controls are necessary to detect and select the target cells.

This method requires a large number of switches ($n+5$) rated at the peak charging current for C . For an ideal system (no ESR in the capacitor or switching losses) with a very large cell imbalance ($B_n = 3.0V$, $B_m = 4.0V$), a flying capacitor could balance these cells at an initial rate of 1Ahr per hour per 1000uF of capacitance switching at 1kHz with an average switch current of 1A. Figuring in the capacitor ESR and switching losses dramatically increases the system's time constant for charging and discharging, effectively reducing actual balancing current by at least an order of magnitude and increasing the peak switch current. The larger the capacitor used, the longer it will take to transfer a usable charge and the clock rate will have to be decreased and the peak switch current will increase. A large (100Ahr) battery pack would require a charge shuttling device with a very large capacitor with extremely large switch currents. A significant amount of energy is dissipated as resistive heating in the switches and capacitor. A large portion of balancing is simply achieved by dissipating the charge from the higher charged cells up as heat.

Another charge shuttling method shares a 'flying capacitor' for every two battery cells (Figure 3). The capacitor constantly switches between the two cells, thereby swapping charge from the higher charged cell to the lower charged cell. Each capacitor only needs simple controls to activate the switches.

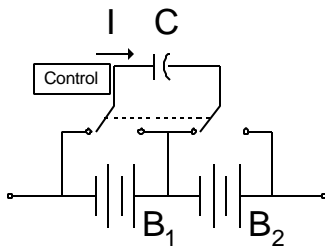

Figure 3. Charge Shuttling Between Two Cells

Several charge shuttling blocks can be cascaded for higher voltage packs (Figure 4). Because cells $B_2 \dots B_{n-1}$ share flying capacitors with their two neighboring cells, charge can travel from one end of the cell string to the other. This method would take a large amount of time to transport charge from high cells to low cells if they are on the opposite ends of the pack because the charge would have to travel through every cell with time and efficiency penalties. This method has a packaging advantage: for every two cells, the control circuitry, power supply and capacitor can be packaged in a single unit powered from the cells they are balancing. Units can be added as cell count is increased.

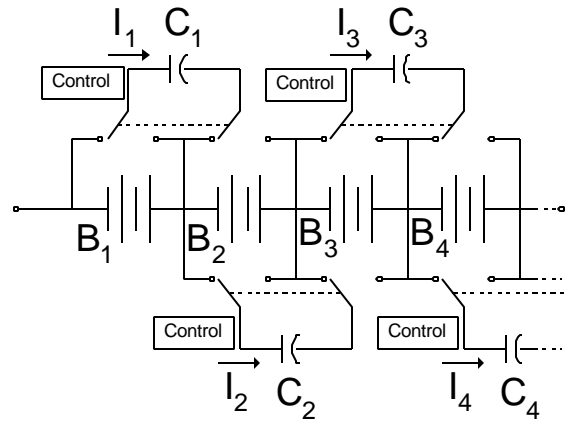

Figure 4. Charge Shuttling with Several Cells

Charge shuttling techniques are of limited usefulness for HEV applications. Lithium chemistries offer a relatively flat open cell terminal voltage across a broad range of SOC from 40%-80% (Figure 5). A cell at a high SOC does not have a significantly large ΔV from a low SOC cell, unless one of those cells are on a voltage 'knee' over 90% SOC or below 20% SOC. HEV batteries operate in the mid-SOC range, and this is where the cell-to-cell voltage differentials are the smallest, thus limiting the usefulness of charge shuttling techniques.

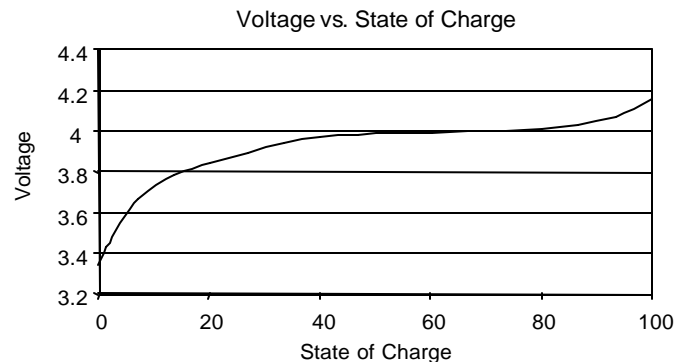

Figure 5. Open Cell Voltage of Lithium Polymer Battery

Charge shuttling techniques are useful for EV applications. Because an EV can be routinely fully charged, the voltage differential between a fully charged cell and a lesser-charged cell is greater near the ends of the voltage curve (Figure 5). This increases the effectiveness of the technique.

ENERGY CONVERTERS

Cell balancing utilizing energy conversion devices employ inductors or transformers to move energy from a cell or group of cells to another cell or group of cells. Two active energy converter methods are the switched transformer and the shared transformer.

The switched transformer method shares the same switching topology as the flying capacitor method (Figure

6). Current I is taken from the entire pack and is switched into transformer T . The transformer output is rectified through diode D and delivered into cell B_n , which is determined by the setting of switches S . Electronic control is required to select the target cell and set switches S .

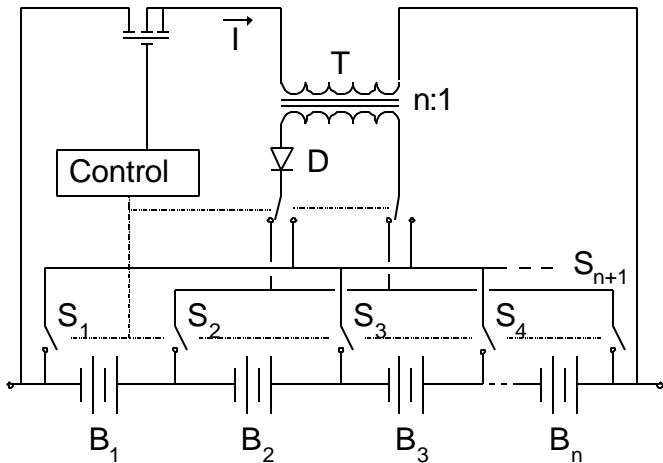

Figure 6. Switched Transformer

This method can rapidly balance low cells at the cost of removing energy from the entire pack. Disadvantages include high complexity, high parts count in terms of control, magnetics, and switches, and low efficiency due to switching losses and magnetics losses.

A shared transformer has a single magnetic core with secondary taps for each cell (Figure 7). Current I from the cell stack is switched into the transformer primary and induces currents in each of the secondaries. The secondary with the least reactance (due to a low terminal voltage on B_n) will have the most induced current. In this way, each cell receives charging current inversely proportional its relative SOC.

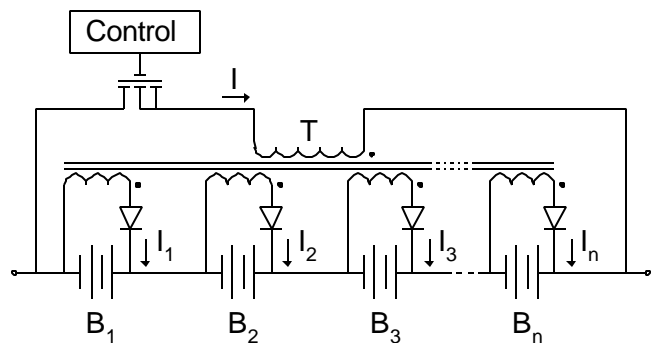

Figure 7. Shared Transformer

The only active component in the shared transformer is the switching transistor for the transformer primary. No closed-loop controls are required. The shared transformer can rapidly balance a multicell pack with minimal losses. Disadvantages of this cell balancing method includes complex magnetics and high parts count due to each

secondary's rectifier. The balancing circuit would have to be designed for the maximum expected number of cells; additional secondary taps could not be easily added.

Several transformers can be used with the same result by coupling the primary windings instead of coupling via a single magnetic core (Figure 8). The benefit of this method is each cell can have its own magnetic core, thus allowing additional cells to be added to the string without altering the host controller.

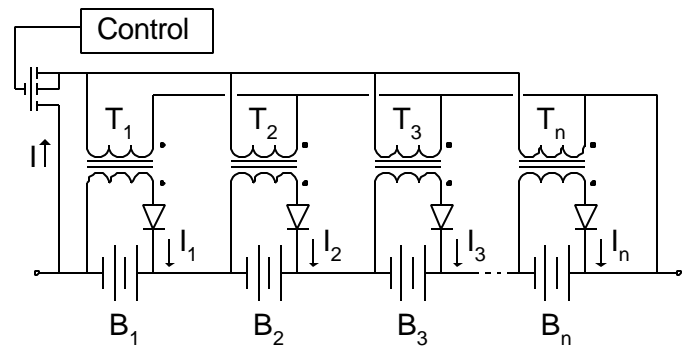

Figure 8. Multiple Transformer

The shared transformer method is suitable for both EV and HEV applications. If current I is designed to be small ($< 100\text{mA/Ahr}$ capacity), the device could operate continuously at a higher efficiency than any of the other active methods.

PASSIVE CELL BALANCING METHODS

DISSIPATIVE RESISTORS

The dissipative method shunts selected cells with high value resistors to remove charge from the highest cells until they match the charge of the lowest cells (Figure 9). This circuit is the simplest and cheapest cell balancing implementation. If the resistor value is chosen so that I is small ($< 10\text{mA/Ahr}$ capacity), the physical resistor size and switch rating can be small. A 10mA/Ahr resistor could balance severely high cells at a rate of 1% per hour. If operated continuously, such a technique could drain the entire battery pack in a few days.

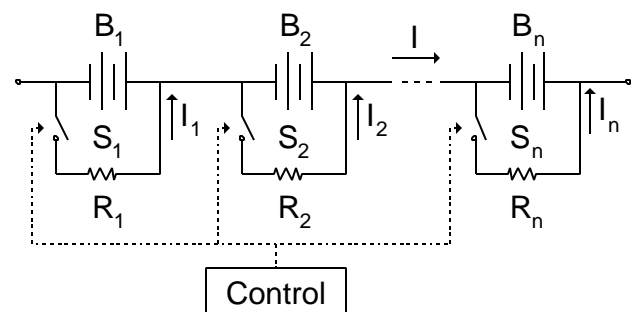

Figure 9. Dissipative Method

The dissipative cell balancing method can be operated continuously, with the resistors turning on and off as required. The effectiveness of the dissipative technique can be improved by the application of adaptive and learning control algorithms.

The dissipative technique is suitable for HEV applications. Advantages are low cost and low complexity. Disadvantages are high energy losses. For EV applications, a 10mA/Ahr resistor could specify a 1A resistor current for a 100Ahr battery pack, meaning a 4W resistor per lithium cell (4V/cell). Such large values could result in a costly design with thermal management requirements.

CONCLUSIONS

Electric vehicle applications can benefit from cell-balancing devices, especially for lithium-based battery chemistries. Since battery pack charging is limited by any one single cell reaching its end-of-charge voltage (4.1 V to 4.3 V), it is useful to control high voltage cells until the lower voltage cells catch up. This way, each cell can be charged to its end-of-charge voltage.

Several cell-balancing methods are suitable for EV applications. Charge shunting methods work well but are limited by the amount of current that must be dissipated. The shared transformer method is applicable, but it is costly in terms of magnetics and parts count. The dissipative method is applicable, and is the most cost effective. Charge shuttling methods would be prohibitively expensive due to the switches required to handle the large peak capacitor charging currents.

Hybrid electric vehicle applications typically feature regenerative braking, battery charging and electric motoring. These features put high demands on the battery pack for both charging and discharging. The battery pack is usually not kept in a fully charged condition; rather it is marginally charged, leaving room at the top for charge acceptance. Thus, charge shunting is not an applicable solution.

Since some HEV designs feature battery packs significantly smaller than their EV counterparts, charge shuttling methods become more attractive with smaller peak switch currents. However, the amount of energy dissipated in capacitor ESR and switching losses may not justify the increased complexity and expense. The dissipative method is effective without the complexity and expense. However, the algorithm development is significantly more involved.

REFERENCES

- [1] N. Furukawa et al, "EV 24h Travel Distance Record Challenge," the 17th International Electric Vehicle Symposium (EVS-17), Montreal, Canada, 2000
- [2] Ph. Blanchard, D. Cesbron, G. Rigobert and G. Sarre, "PERFORMANCE OF SAFT LI-ION BATTERIES FOR ELECTRIC VEHICLES," the 17th International Electric Vehicle Symposium (EVS-17), Montreal, Canada, 2000
- [3] M. Okada, H. Yasuda, M. Yamachi, E. Yagasaki, and S. Hashizume, "Porous Polymer Electrolyte Li Ion Battery with Superior Performance," Electric Vehicle Symposium 16 (EVS16), 1999
- [4] Segawa, M., S. Hitomi, H. Yasuda, M. Yamachi, "Effects of Porous Polymer Electrolyte on Electrochemical Characteristics for LiNi_{1-x}CoxO₂/C System Lithium Ion Cell for Electric Vehicles," the 17th International Electric Vehicle Symposium (EVS-17), Montreal, Canada, 2000
- [5] H. Horiba, K. Hironaka, T. Matsumura, T. Kai, M. Koseki and Y. Muranaka, "Manganese Type Lithium Ion Battery for PEV and HEV Use," the 17th International Electric Vehicle Symposium (EVS-17), Montreal, Canada, 2000
- [6] Keyser, M., A. Pesaran, M. Mihalic, "Charging Algorithms for Increasing Lead Acid Battery Cycle Life for Electric Vehicles," the 17th International Electric Vehicle Symposium (EVS-17), Montreal, Canada, 2000
- [7] E. Sexton, "Improved Charge Algorithms for Valve Regulated Lead Acid Batteries," IEEE 00TH8490, in *Proceedings of the 15th Annual Battery Conference on Applications and Advances*, Long Beach, California, January 11-14, 1999, 211-216.
- [8] Dennis Corrigan, et al., "Ovonic Nickel-Metal Hydride Electric Vehicle Batteries", the 12th International Electric Vehicle Symposium (EVS-12), Anaheim, CA, Dec., 1994
- [9] W. Josefowitz, D. Macerata, H. Mettlach, D. Porcellato, N. Farin, J. Hansson, "EV Energy Bench Testing - European Testing Report," the 17th International Electric Vehicle Symposium (EVS-17), Montreal, Canada, 2000