

# A Review of Common Problems in Design and Installation of Water Spray Cooling and Low Expansion Foam System to Protect Storage Tanks Containing Hydrocarbons Against Fires

**A Technical Report**

*Iraj Alimohammadi<sup>1</sup>, Farshad Nourai<sup>2</sup>, Mohammad Javad Daryalaal<sup>3</sup>, Amir Masood Ghasemi\*<sup>4</sup>*

1) Department of Occupational Health Engineering, School of Public Health, Iran University of Medical Sciences, Occupational Health Research Center, Tehran, Iran

2) Aftab Imen Parto Consulting Engineers Ltd, Tehran, Iran

3) Subsidiary HSE Department at Iranian Oil Company, Tehran, Iran

4) Department of Occupational Health Engineering, School of Public Health, Tehran University of Medical Sciences, Tehran, Iran

\* Author For Corresponding: [journalqasemi@gmail.com](mailto:journalqasemi@gmail.com)

Received: 10 Mar. 2015 , Revised: 20 July. 2015, Accepted: 25 Aug. 2015

## ABSTRACT

Tank fires are rare but carry significant potential risk to life and property. For this reason fire protection of tanks is critical. Fixed Low expansion foam and water spray cooling systems are one of the most effective and economical ways to reduce damages to a tank from fire. Such systems are currently installed in many companies but are not effective enough and require involvement of firefighters which in turn threaten their lives. This paper studies in a systematic way the problems of foam and cooling systems currently installed in a few domestic companies which operate storage tanks with focus on floating and fixed roof atmospheric tanks containing hydrocarbons and offers possible solutions for more efficient installation, design and operation of such systems.

**Key words:** Storage Tank, Cooling System, Fire Protection, Spray System, Spray System Design, Tank Fire, Problems, Foam System

## INTRODUCTION

Storage tank is a familiar part of industrial landscape. They are used to store bulk materials. Tanks are also constructed and utilized where there is a pause or unequal consumption /production rates between different processes [1]. In almost all cases, the risk factor associated with storage tanks is substantial because of the relatively large quantities of fuels that are stored in one location. Fire protection principles and designs have been incorporated into national codes and standards and adopted by legislative bodies throughout the world. Many industries have generated additional practices that are more conservative than those required by the codes [2-4]. Fire protection reduces the damages to the tank and could mitigate the consequences [5-7].

The most common types of fire protection for storage tanks [8] are low expansion foam system for extinguishment and water spray system for cooling the tank. The cooling system provides protection against internal fires and radiant heat from external fires [9-11]. The radiant heat can be reduced by increasing distance but this is not always possible [12-14] and hence cooling systems are used [4]. The mentioned systems are very popular due to the low

cost of installation and ease of operation as well as the high level of protection and reliability they provide. Numerous tank constructors install such systems as a standard safety feature of tanks at the request of operators.

As more experience is gained by installing and testing new systems the known problems are designed out. This article is written to carefully study problems in foam and cooling systems currently installed and is intended to help adopt better practices and apply corrective solutions in design, construction and installation of such systems.

For this purpose problems in foam and cooling systems are divided into three major categories:

1. Problems associated with the tank
2. Problems associated with the cooling system
3. Problems associated with the foam system

### **PROBLEMS ASSOCIATED WITH THE TANK**

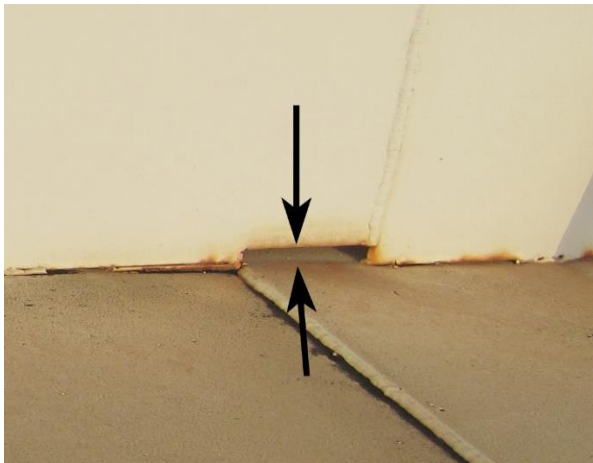
The design of tank components and piping system and their relative positions and orientation are important in overall system effectiveness. Meeting the requirements of codes and standards helps achieve a more efficient system.

### **Tank design problems related to foam system**

Problems that are associated with the tank in relation to foam system are described below:

1. Drainage Slots: nonstandard drainage slots at the bottom of the foam dam drain more foam solution than enters the rim seal area. The area of the drainage slots is specified in NFPA 11 as being  $278 \text{ mm}^2$  for every square meter of the dammed area. Drain slot height is restricted to 9.5mm [15]. In many tanks, the slot area is much more and causes excessive foam drainage from dammed area. This in turn causes no foam to reach the areas of foam dam not directly above the discharge device.

2.-Foam Dam Fastening Method: Fastening of dam plates to roof is very important. If fastening is not carried out properly more drainage area will be available and no foam build up occurs. To solve this problem foam dam plates shall be fastened to roof plates. So as to make a leak proof joint [15]. For foam dams fastened by nuts and bolts the gap between plates of foam dam or foam dam plates and roof plates is another place for excessive foam drainage. Welding is the most reliable method of fastening foam dam plates and use of nuts and bolts is highly prohibited due to inadequacy in sealing the foam dam.



**Fig. 1:** Non-standard Drain Slots



**Fig. 2:** Excessive Foam Drainage from under the Foam Dam Due to Non-standard Slot Size



**Fig.3:** Excessive Foam Drainage from Foam Dam Causes Localized Foam Application



**Fig. 4:** Foam Dam Fastening Using Nuts and Bolts

3- Detrimental Modifications to Foam Dam: in some tanks the vent or other tank components are located near the foam dam and the dam is cut or modified in a way that affects foam build up in the rim seal area (Fig. 5). To solve this problem with the foam dam is run around the component just the way such method is applied for guide and anti-rotation poles (Fig. 6 and Fig. 7). In a few cases, the foam dam height is reduced in some places by cutting the dam plate. This must be avoided due to foam loss over the dam and inadequate foam coverage over the secondary seal (Fig. 8).

4- Non-standard Foam Dam Dimensions: NFPA 11 standard specifies that foam dam shall be a minimum of 305mm high and its height shall be a minimum of 51mm higher than any metal secondary seal [15]. In many tanks foam dam height does not satisfy the

standard specifications and dam height in the rim seal area is not enough to ensure the necessary foam height and extinguish the fire (Fig. 9). The width of foam dam is also restricted to a maximum of 0.6 m from a tank shell which is not observed in some tanks (Fig. 10) [15].



Fig. 5: Detrimental Foam Dam Modifications



Fig. 6: Tank Components Excluded from Dammed Area



Fig. 7: Tank Components Included in Dammed Area

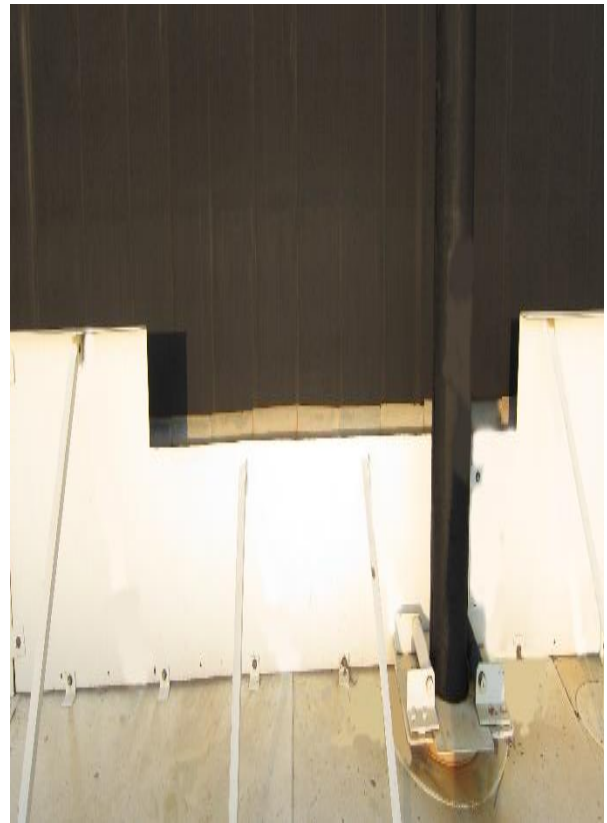


Fig. 8: Foam Dam Localized Height Modification





**Fig. 9:** Inappropriate Foam Dam Height



**Fig. 10:** Inappropriate Foam Dam Width

5-Foam Blockage inside Dammed Area: foam dam design around guide and anti-rotation poles and other tank components located in or near rim seal area is important because of the need for flow of foam within rim seal area between two adjacent discharge devices. In some tanks, the foam dam is so designed

that the flow of foam is blocked by tank components (Fig. 11). To solve this problem foam dam plates are so shaped as to keep the same distance from tank components as from the tank shell (Fig. 12). This causes the foam to flow easily past them and reach farther areas.



**Fig. 11:** Foam Blockage by Guide Pole Due to Poor Design of Foam Dam



**Fig. 12:** Good Design of Foam Dam around Guide Pole

### *Tank design problems for cooling system compatibility*

1-Water Curtain Blockage by Support Members: use of triangular support members under the top walkway of the tank hinders the water curtain ejecting from spray nozzles (Fig. 13) [16]. Dry areas in the form of strips form where the curtain is blocked and the strip continues down to the below stiffening ring or to the bottom of the tank if no wind girders exist below. To solve this problem, it is best to use slender members to support the top walkway (Fig. 14). For previously installed members the triangular support plate can be cut and an angle member should be added to provide support for the outer edge of the walk way (hatched area of Fig. 15 is needed to be cut). Triangular support plates for lower wind girders rarely pose a problem but the same remedy can be applied as well just in case.



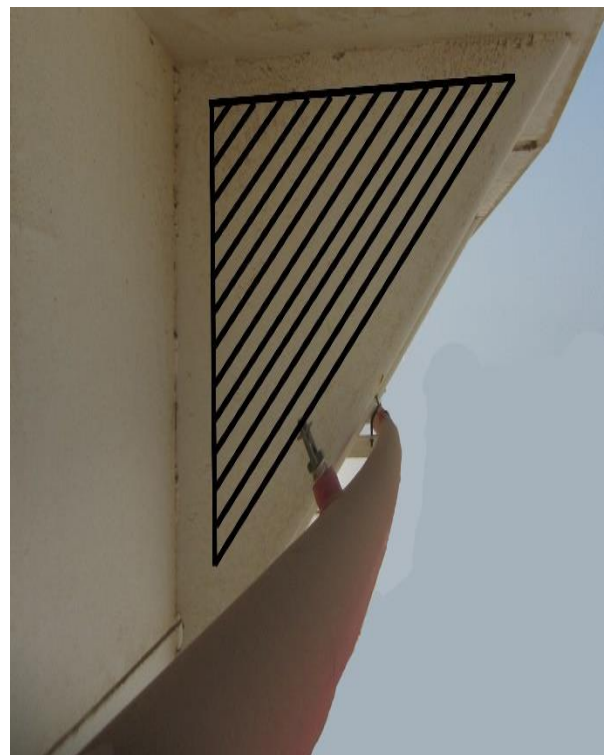
**Fig. 13:** Water Curtain Blockage by Triangular Support Members

2-Water Film Blockage by Stairway: stairways which are attached to the shell disrupt the water film and the shell area below the stairway is left dry (Fig. 16, Fig. 17). One way to solve this problem is to completely separate the staircase separated from the tank and construct it as a self-standing structure next to the tank (Fig. 18). The other way is to insert a space between the tank and the spiral stairway and support

the whole stairway by means of a few brackets on the shell (Fig. 19, Fig. 20). This allows the flow of water down the shell and past the stairway so no dry area forms under it.



**Fig. 14:** Slender Support Member for Walkway



**Fig. 15:** Triangular Support Member Modification



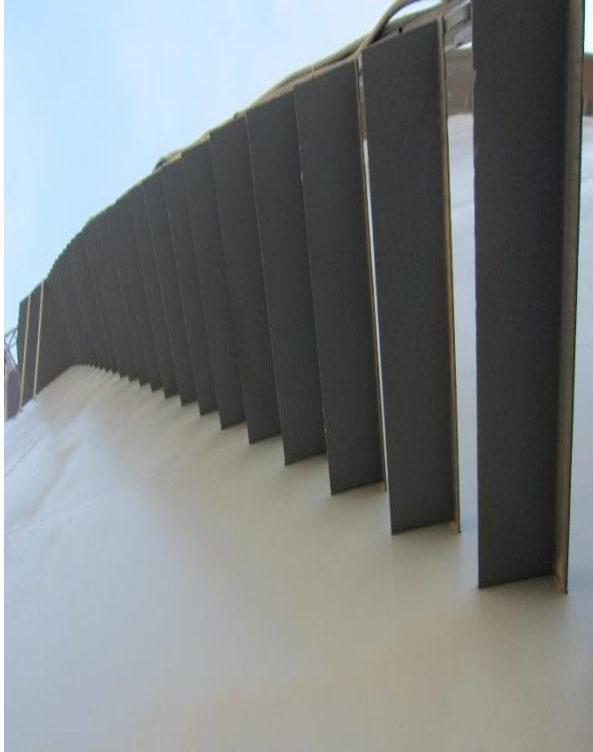


Fig. 16: Spiral Stairway with Steps Attached to Tank Shell



Fig. 17: Spiral Stairway with Steps Attached to Tank Shell

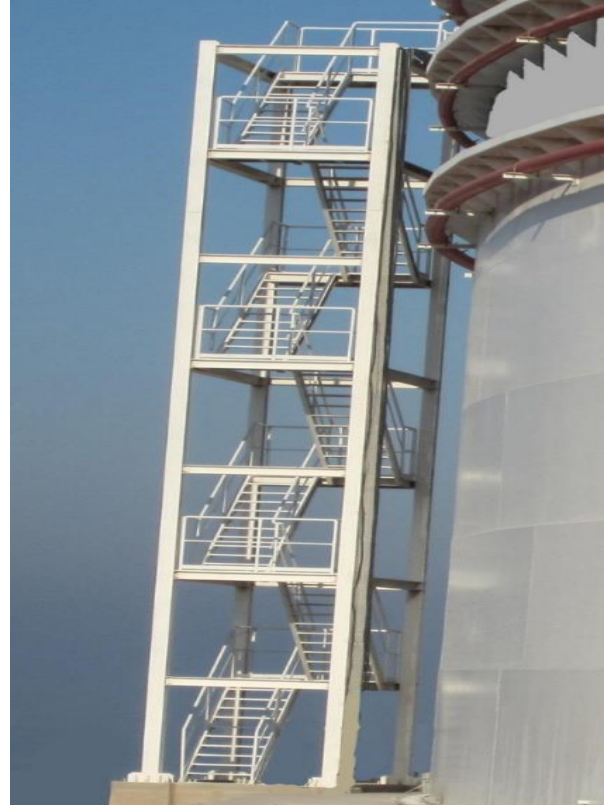


Fig. 18: Staircase Structure Constructed Next to Tank

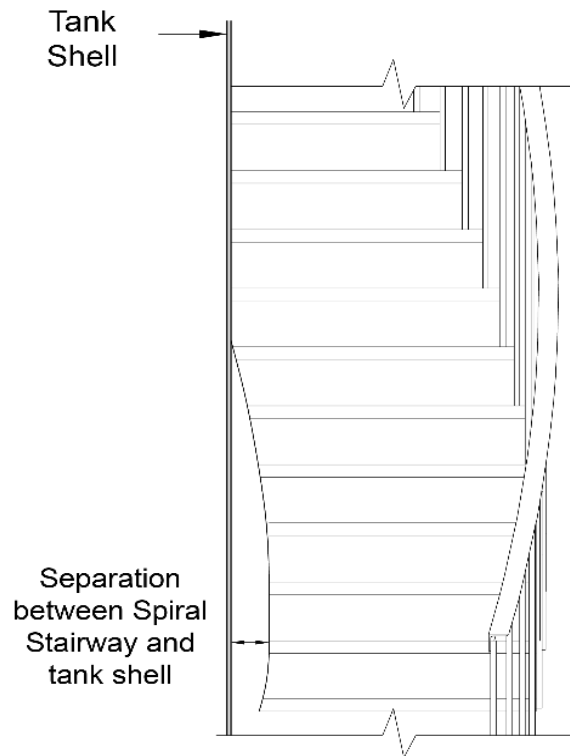


Fig. 19: Spiral Stairway Separated from the Tank Shell



**Fig. 20:** Spiral Stairway Separated from Tank Shell

#### **PROBLEMS ASSOCIATED WITH THE COOLING SYSTEM**

1. Faulty or No Hydraulic Calculations: some systems are installed without any hydraulic calculations and merely an array of piping is set up on the tank shell. Such systems are not fully operable even in high pressures mostly because the pipe sizes are not large enough to deliver the required or designed water flow rate from spray nozzles [17]. Pipe sizing shall be carried out to give a minimum pressure drop along the pipe run between the closest and the farthest nozzle. Excessive pipe size reduction usually causes pressure drop and adversely affects water spray pattern and characteristics [18].

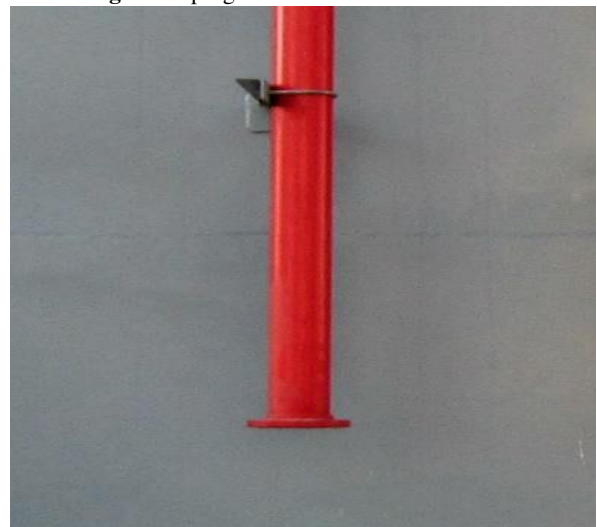
2. Location of Fire Department Connection: in some tanks the riser pipe is terminated at tank bottom which requires entering the diked area of a tank (Fig. 21). To solve this problem, the piping is required to be extended to the dike wall so that running the system is possible without entering the diked area. In some tanks the fire department connections are not installed meaning the whole system is not operable (Fig. 22).

3. Inappropriate Nozzle Selection: the selection of nozzles affects the efficiency, the level of protection of the cooling system offers and also the amount of water wastage [16,19]. The type of nozzle usually used for cooling a vertical surface is flat fan nozzle. For some tanks medium velocity nozzle [20] with cone shaped spray pattern is used which wastes considerable amount of water (Fig. 23). Wastage of

water minimizes if the nozzle is installed horizontally so that the cone is normal to the tank surface. For some nozzles, the discharge angle of water spray is 180 or more. Such nozzles are used as water curtain and are not appropriate for cooling vertical surfaces because of high wastage. Although NFPA 15 standard requires manufacturers to mark flow and pressure characteristics on spray nozzle body, some spray nozzles used in cooling systems bear no marking [15]. It is found in some cases that the flow rate of spray nozzles is not according to mark for nozzles. In a few cases, the right type of nozzle is not selected and the flow characteristics of nozzles installed on the cooling system are not according to hydraulic design of the system.



**Fig. 21:** Piping Terminated at Tank Bottom

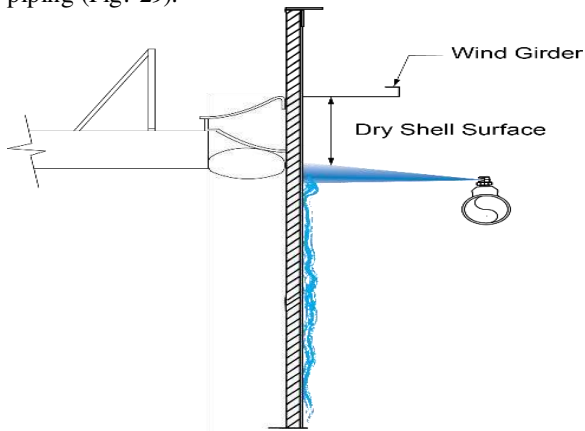


**Fig. 22:** Cooling System with No Fire Department Connections

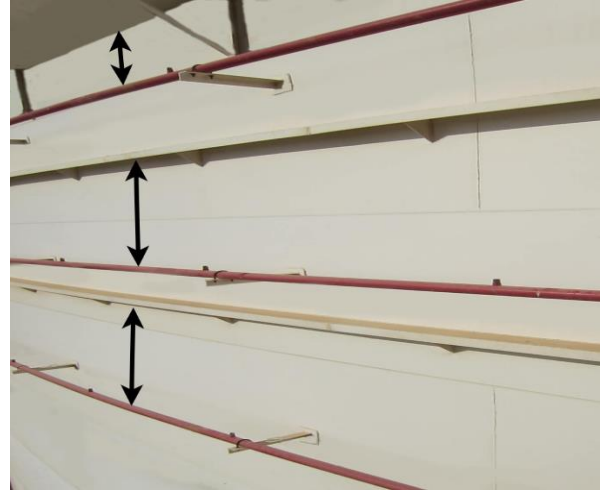


**Fig. 23:** Inappropriate Spray Nozzle - Full Cone Medium Velocity Nozzle

4-Inappropriate Water Ring Main Position: the location of the ring main relative to tank protrudances and the deflection of spray nozzles from vertical is vital to achieve full coverage and avoid dry areas. In some tanks the ring main is installed far below the wind girder so the part of the tank shell above the ring main and below the wind girder remains dry (Fig. 24 and Fig. 25). Installation of ring mains close to tank components results in plugging of outlets or cutting of wind girder support to allow for nozzle installation (Fig. 26 and Fig. 27). Spray pattern for such nozzles is also distorted and partly blocked. In a few cases, the water ring main is not installed for cooling the area of the shell between two wind girders (Fig. 28). In some designs, the nozzle is located in 6 o'clock position of the ring main pipe. This aggravates the problem of incomplete wetting of the shell area above the ring main and below the wind girder and is not recommended. It is worth mentioning that this design ensures better drainage and hence limited water accumulation occurs in the piping (Fig. 29).



**Fig. 24:** Schematic of Dry Shell Surface



**Fig. 25:** Dry Shell Surface above Water Spray Cooling Ring Main



**Fig. 26:** Cutting Wind Girder Support to Allow Installation of Spray Nozzle



**Fig. 27:** Blockage of Outlets by Tank Appurtenances





**Fig. 28:** Providing No Cooling Ring above Wind girder

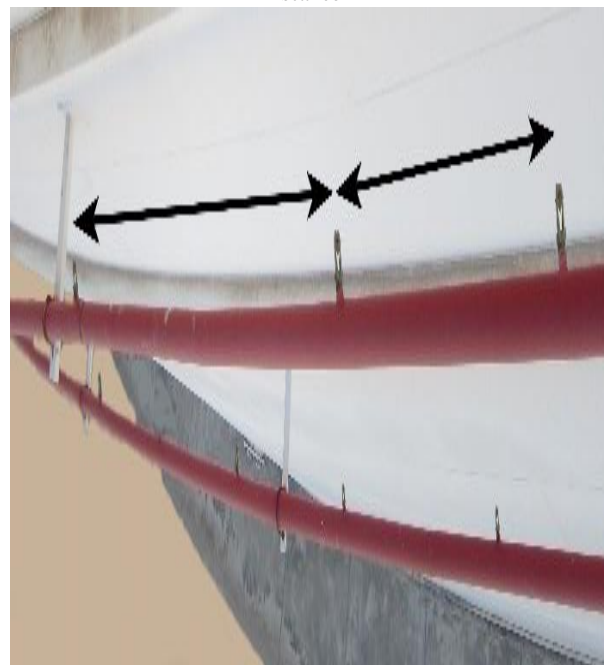


**Fig. 29:** Water Spray Nozzles Installed in 6 O'clock Position of Ring Main

5-Incomplete Nozzle Water Curtain Overlap: in order to avoid dry areas water curtain of nozzles is required to overlap. For some cooling systems which use two half rings to cover the circumference of a tank, the water curtains of terminal nozzles on the half rings do not overlap mostly because of great distance between the ends of the two rings or inappropriate nozzle position there and a dry strip forms as a result (Fig. 30). In some case the spray nozzles are not installed at regular intervals or the distance between outlets is greater than the recommended separation of nozzles by the manufacturer (Fig. 31).



**Fig. 30:** Dry Strip Due to Inadequate Nozzle Separation Distance



**Fig. 31:** Nozzles Installed at Irregular Intervals

6-Cooling System of Fixed Roof Tanks: cooling of the roof of fixed roof tanks is important because of the higher incident radiation level [21]. In some fixed roof tanks cooling of the roof is neglected (Fig. 32). Total exposure protection for fixed roof tanks includes spraying the shell and roof by water (Fig. 33). The piping for the cooling of the roof and shell of some fixed roof tanks are not separated (Fig. 34). As the roof of fixed roof tank is attached to the shell by frangible weld and because the roof and shell cooling system piping is not separated, the mentioned cooling system is rendered useless upon an internal explosion in the tank. So the cooling systems for the roof and shell are required to be fed from two valved separate lines (Fig. 35).



**Fig. 32:** Fixed Roof Tank with No Roof Protection



**Fig 33:** Cooling System for Shell and Roof of a Fixed Roof Tank



**Fig 34:** Connected Roof and Shell Water Spray Cooling System



**Fig. 35:** Separated Roof and Shell Water Spray Cooling System

7-No Provision for Flushing: in some cooling systems the end of ring main is capped and permanently closed so flushing the piping is not possible (Fig. 36). Use of a flanged end which is blinded (Fig. 37) is one way to solve the problem but the better way is to use a valve with an equal bore at the end of the ring main (Fig. 37). If the valve is positioned so as to be accessible from the emergency ladder or stairway of the tank, flushing the system is carried out without the need for lifting equipment.



**Fig. 36:** Ring Main with End Cap

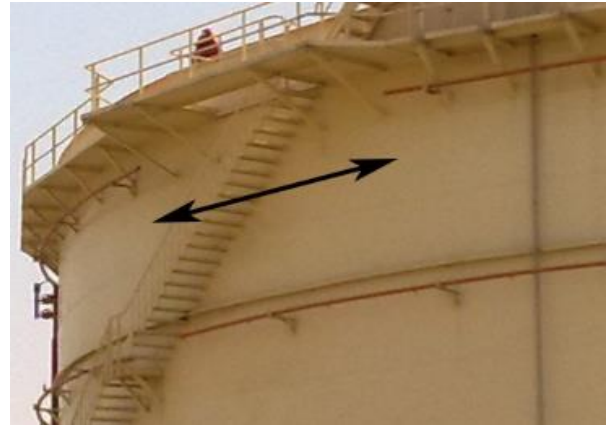


**Fig. 37:** Ring Main with Flanged End

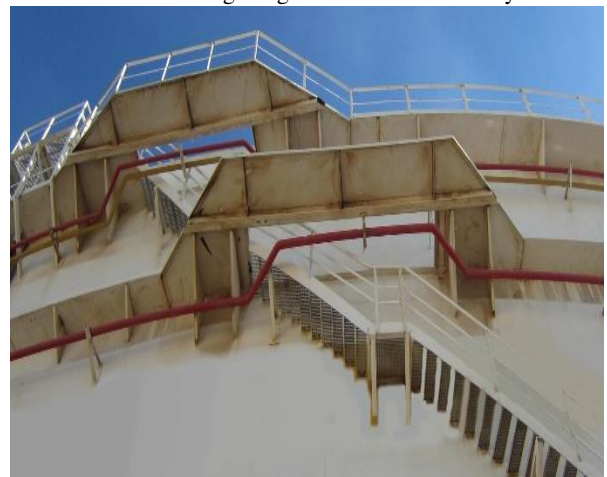


**Fig. 38:** Ring Main with a Valve at the End

8-Dry Shell Surface above Stairway and Top Walkway: in some tanks the cooling of the shell is not carried above the staircase because the piping is terminated at the stairway (Fig. 39). To leave no dry spots on the shell at this place, it is required to run the pipe around the stairway (Fig. 40). In most cooling system designs the shell of the tank above the walkway is not sprayed by water. Due to higher levels of radiation in this location the installation of a cooling system is deemed necessary.



**Fig. 39:** Dry Strips Above and Below the Stairway Due to Lack of Cooling Ring Main Around Stairway



**Fig. 40:** Cooling Piping Around the Stairway

9-Pressure Gauge: it is required by NFPA 15 to install a pressure gauge at the location of the most remote nozzle [16]. The gauge gives the status of the system and its operability. This requirement is not observed in most cases.

10-Use of Strainers: it is required by NFPA 15 standard to install strainers in the main pipeline of water spray system utilizing nozzles with waterways smaller than 9.5mm [16]. In some systems strainers are not installed. To reduce maintenance of such systems it is necessary to use strainers with appropriate perforation size in the main pipeline.

#### **PROBLEMS ASSOCIATED WITH THE FOAM SYSTEM**

Type of foam system usually used for protection of storage tanks is the low expansion foam system. By nature, the foam system is important and its operation is required to be optimum. The problems associated with this system are listed below:

1. Faulty or No Hydraulic Calculations: the hydraulics of foam system directly affects its foam generation and performance. In some tanks, the foam system is installed without any hydraulic calculations. The uniform pressure along the ring



main is vital. Most manufacturers set their device's working pressure at 7 bars. As far as foam generation is concerned pressures around 7 bars are preferred. Speed of fluid in piping is also important since the time for foam to reach the discharge devices depend on it: durations under 2.5 up to 3 minutes for foam solution to reach the tank is preferred. The total foam and discharge rate from devices need to conform or surpass the NFPA 11 recommended value [15]. In some tanks of the foam pourer capacity is not suitable for the tank. If the discharge rate is higher than is required more intense logistics are needed and resources are wasted [22]. If the rate is lower the probability of extinguishment of fire is lower. The protection against full surface fire for large diameter floating roof tanks is not provided but it is recommended to install such systems for smaller tanks.

2. Location of Fire Department Connection: the foam system feeder pipe is terminated at tank bottom which requires entering the diked area in order to operate the system (Fig. 41-a). The piping is required to be extended so that feeding the system is done without anyone entering the diked area (Fig. 41-b) [15]. In some cases the fire department connections are not installed (Fig. 42).

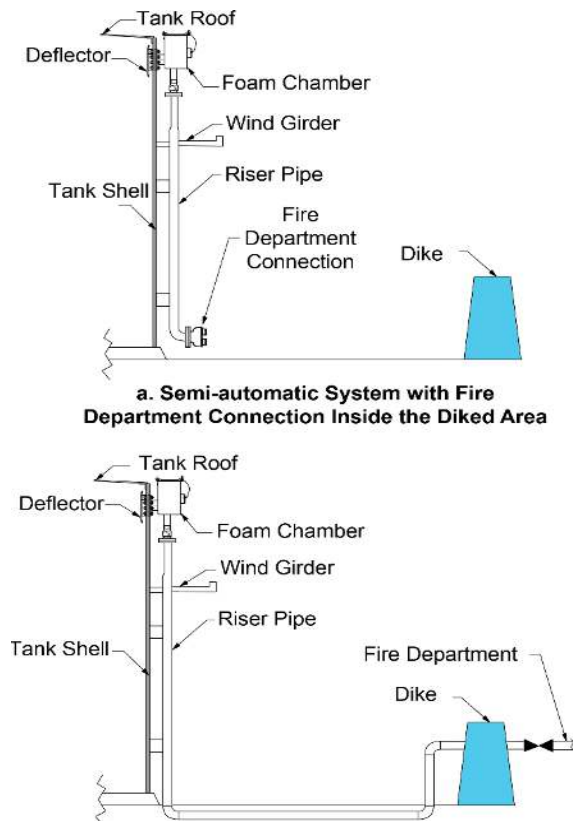


Fig. 41: Fire Department Connection Position



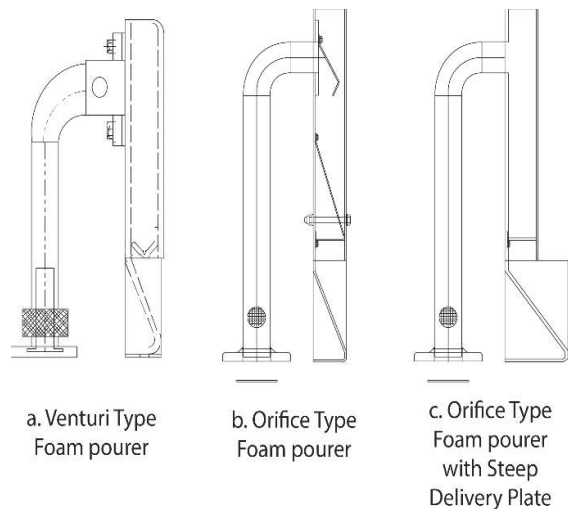
Fig. 42: Foam System with No Fire Department Connections

3-Foam Discharge Devices Design: the foam pourer design is of high importance. In some cases, the generated foam by a foam pourer manufactured by one of domestic companies is thrown away from the device so most of foam ends outside the foam dam and is wasted (Fig. 43).

The quality of generated foam is also very important. The aeration of foam solution and foam generation in some foam makers is carried out by an orifice plate whereas in other types a venturi is used for foam making (Fig. 44). Site tests of these two types of foam pourers proved the venturi type performs better.



Fig. 43: Throwing of Foam Stream by Foam Pourer



**Fig. 44:** Foam Pourer Types

**4-Foam Discharge Devices Installation:** In some tanks foam pourers are located right above the overflow windows of the tank and most of generated foam exits the tank and is wasted (Fig. 45).

NFPA 11 specifies the maximum distance between foam pourers as 24.4 m for tanks with 60cm wide foam dams [15]. In some instances, this distance is not observed due to inadequate number of foam pourers or in order to avoid positioning the foam pourers above overflow windows.

The positioning of foam pourers near the guide and anti-rotation pole is of high importance. Although the minimum distance of 12.2 m is met if requirements of NFPA 11 standard are observed, the distance is preferred to be minimal since these areas are most prone to fire and are also used as a station for fighting tank fires.

In some tanks the foam pourer is not fixed at the top angle of the tank so the generated foam does not adhere to the inner wall of the tank and some is wasted (Fig. 46). The likelihood of generated foam to be affected by wind or the device to break down under wind induced vibrations is higher.

It is highly important to install the foam pourer so the front edge of the device is on the edge of the tank. This ensures the generated foam to run down the inner wall of the tank without any throwing of foam. This installation feature is not observed in some tanks (Fig. 47). The main reason for this problem to occur is that the distance between the center of foam ring main and the inner wall of the tank is not equal to the distance between the center of inlet pipe of foam pourer and the front edge of the device (Fig. 48). This distance needs to be determined during the design phase. It is required to ensure a uniform distance between the center of the pipe and the inner tank wall during construction and installation (Fig. 48 - c).

In some tanks the ring main is installed on the top angle and foam pourers are located just inside the tank (Fig. 49). This is the extreme case of the problem discussed in the previous paragraph. The foam produced does not run down the inner wall and falls freely. The wastage in this case is very high and foam stream is adversely affected by winds.

In some cases, the foam chamber is attached to the roof of a fixed roof tank (Fig. 50 and Fig. 51). Since the roof of fixed roof tanks is designed to separate from the shell the whole foam system is rendered inoperable in case of an explosion [22].

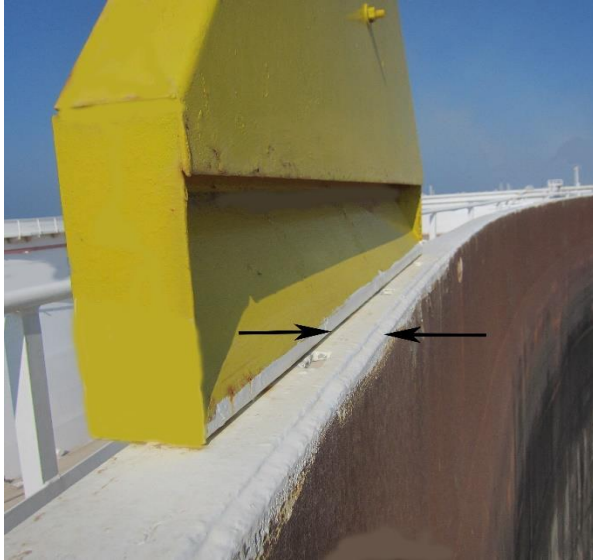
In some tanks the farthest foam pourer and its branch pipe is not close to the end of foam solution ring main and a dead area forms which causes corrosion and possible full bore clogging. It is best to locate the farthest foam pourer as close as possible to the end of the ring main so that the system can be flushed without opening any flanged joint.



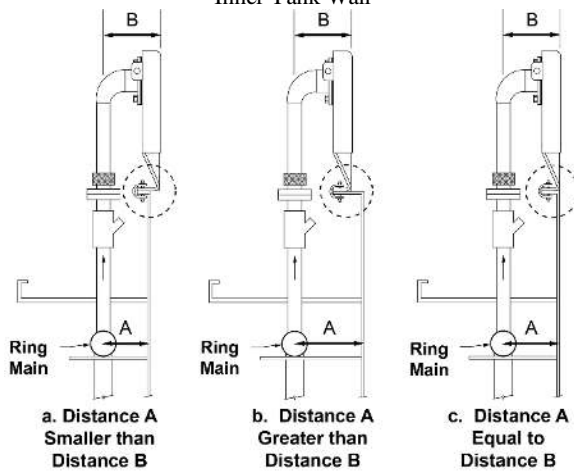
**Fig. 45:** Positioning of Foam Pourer Above Overflow Slots



**Fig. 46:** Foam Pourer Not Fixed to Top Angle



**Fig. 47:** Foam Pouwer Positioned with Indentation from Inner Tank Wall



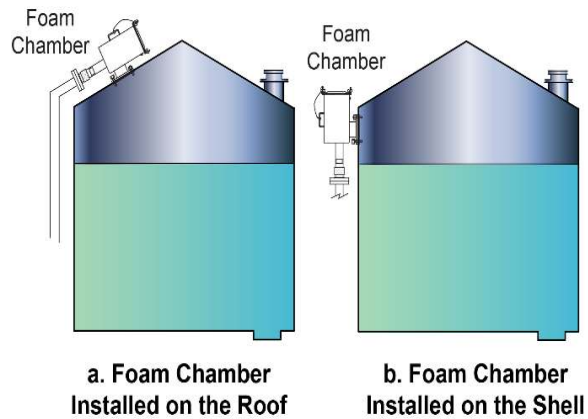
**Fig. 48:** Foam Pouwer Installaton on Top Angle



**Fig. 49:** Foam Pouwer Sticking inside the Tank

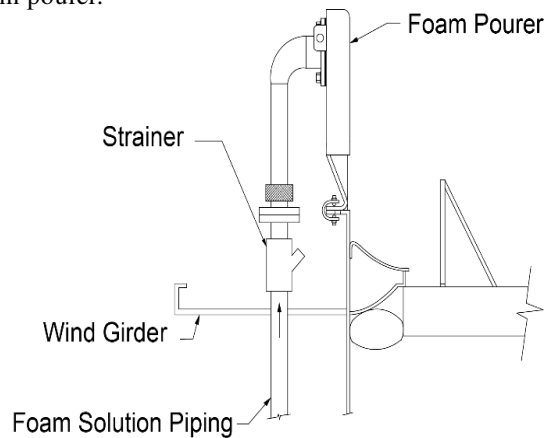


**Fig 50:** Installation of Foam Pouwer on the Roof of Fixed Roof Tanks



**Fig. 51:** Foam Chamber Installation for Fixed Roof Tanks

5-Use of Strainers: strainers are commonly not used upstream of foam pouwers but it's necessary since strainers prevent clogging the foam pouwer venturi or orifice plate and the maintenance of strainers is much simpler than foam pouwer. It is recommended to use a strainer upstream of each foam pouwer.



**Fig. 52:** Strainer Upstream of Foam Pouwer



6-Ring Main Position: foam ring main for some tanks is placed above the walkway (Fig. 53 and Fig. 54-a). This type of installation limits the vital space available around top periphery of the tank and also the pipe support for the ring main acts as an obstruction and frequently causes tripping and injury to foot. The better design is to install the main ring below the walk way ( Fig. 54-b).



Fig. 53: Foam Solution Ring Main Above Walkway

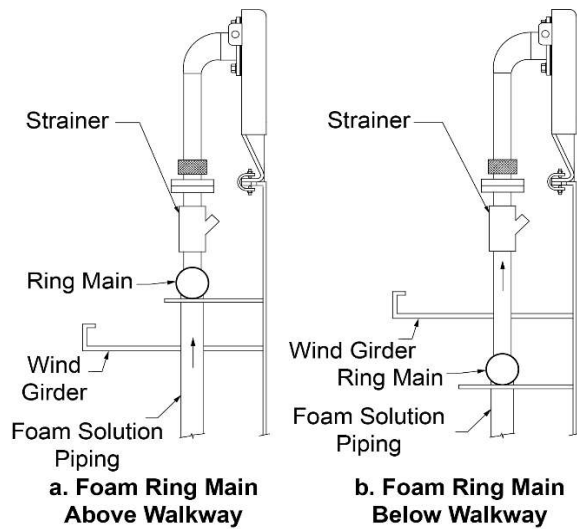


Fig. 54: Foam Ring Main Position

7- Unequal Flange Sizes: in some systems the branch pipes feeding the foam pourers from the ring main terminates in a flange with a different size from the foam pourer inlet flange (Fig. 55). This problem is usually solved by flange bolt hole modifications. To solve this problem, it is required to change the flange

and pipe size of the branch to conform to inlet flange of the foam discharge device.



Fig. 55: Incompatible Ring Main Branch Pipe and Foam Pourer Flange Sizes

8-Pressure Gauge: in some foam systems pressure gauge or taps are not provided. Pressure indicating devices is important since foam making process is highly pressure dependent. It is necessary to provide pressure gauges at closest and farthest points of the foam solution ring main to feeder pipe in order to verify correct operation of the foam system during tests and in fire situations (Fig. 56) [15].



Fig. 56: Tap for Pressure Gauge

9-Linear Heat Detector Placement: in automatic foam systems a sensing element called linear heat detector is used to actuate the system. It is necessary to install linear heat detectors as close as possible to the source of fire [22]. In some cases, they are attached to foam damplate which causes a long delay in fire detection due to greater distance to the source of fire. The best place to install the detector is on the weather shield of floating roof tanks (Fig. 57).

In some automatic system design one strand of linear heat detector is placed which increases the chance of

false alarm and system actuation. To make the system more reliable it is recommended to use two linear heat detectors (Fig. 57) and define the logic based on pre-alarm and alarm states.

Since the linear heat detector is placed right above the rim seal of the tank and this area is classified as zone 0 the use of current limiting devices known as barriers is mandatory. This important feature was neglected in a few designs.



**Fig. 57:** Linear Heat Detector

10-Foam Handline: a handline is a hose stream mainly used for small roof fires and supplements the primary protection [15]. The connection is valved and shall be provided at the top rim of the tank (Fig. 58). This connection provides for fighting small fires on the roof and rim seal area. This connection is not considered for various tanks.



**Fig 58:** Foam Handline

11-Provision for Flushing: in some systems the end of the foam ring main pipe is permanently closed and flushing of piping is not possible (Fig. 59) [15]. Due to high risk of clogging it is necessary to flush the system periodically so use of flanged end connections is recommended (Fig. 60).



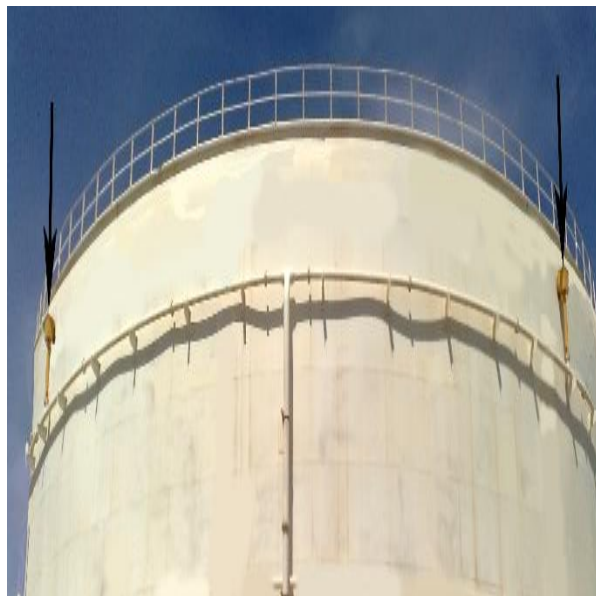
**Fig. 59:** Foam Ring Main with End Cap



**Fig. 60:** Foam Ring Main with Flanged End

12-Foam System for Fixed Roof Tanks: use of ring main for distribution of foam solution to foam chambers for protection of fixed roof tanks containing flammable liquids [12] is not allowed

[Fig. 61) [15]. The permissible design is to use separate valved piping for every chamber.



**Fig. 61:** Installation of Foam Chamber on a Header for a Tank Containing Flammable Liquid

## DISCUSSION

Water spray cooling and low expansion foam systems are not complex systems but ignoring simple features in their installation or design could render the whole system inefficient or fatally inoperable. Problems such as “non-standard foam drainage slots”, “inappropriate foam dam fastening”, “detrimental foam dam modifications”, “non-standard foam dam dimensions”, “foam flow blockage inside dammed area”, “inappropriate cooling ring main position”, “incomplete water spray nozzle overlap”, “inappropriate foam discharge device installation” and “linear heat detector position” are mainly installation and construction problems which are due to lack of supervision and/or knowledge of supervisor. Other problems like “water curtain blockage by support member”, “water film blockage by spiral stairway”, “faulty or no hydraulic calculations for foam and water spray system”, “inappropriate water spray nozzle selection”, “using a single riser pipe for cooling the roof and shell of fixed roof tanks”, “no provisions for flushing for foam and cooling system”, “dry shell areas due to lack of water film”, “not considering pressure gauge for foam and cooling system”, “inappropriate foam pourer design”, “use of strainers for foam and cooling system”, “foam ring main position”, “unequal flange sizes in foam system”, “lack of foam handline at top rim of the tank”, “use of foam ring main instead of separate valved lines for fire protection of fixed roof tanks containing flammable liquids” are primarily

design problems and are required to be solved in designing phase. The solutions recommended for each problem in the body of the article is based on cost and feasibility. The designer is required to build such features into the design of foam and water spray cooling system and also guide the installer to observe them.

## CONCLUSION

Most of studied problems in this article make the system inefficient whereas few make it totally inoperable: installing a foam pourer above the overflow window causes high wastage while using a single riser pipe for cooling the roof and shell of a fixed roof storage tank renders the whole system inoperable in case of an internal explosion in the tank. The study of foam systems and their associated problems shows that inefficiency in such systems is potentially more risky. This in part is due to the nature of foam system purpose and sensitivity of foam making process. Therefore its design, construction and installation requires greater attention. Finally to make progressive improvements, it is recommended to continuously gather and share knowledge on the newer problems as more foam and water spray cooling systems are installed and tested.

## ETHICAL ISSUES

The authors declare they observed and comply with ethical policies of the journal.

## COMPETING INTERESTS

The author(s) declare that they have no competing interests.

## AUTHOR'S CONTRIBUTION

The corresponding author has been involved in conception of the idea, acquisition, analysis and interpretation of data and drafting the manuscript. The third author made great contribution to the gathering and interpretation of data. The first and second authors revised the manuscript for important intellectual content and gave final approval of the version to be published.

## ACKNOWLEDGEMENT

We would like to acknowledge with appreciation the support of Sajad Abbasali and Mohammad Reza Kazemi.

## REFERENCES

- [1] Mannan, S. Lees' Loss Prevention in the Process Industries: Hazard Identification, Assessment and Control. Elsevier Science & Technology Books. 2004.



- [2] Persson, H, Lonnermark A., Tank Fires: Review of Fire Incidents 1951-2003. BRANDFORSK Project 513-021. 2004. SP Sveriges Provnings- och Forskningsinstitut.
- [3] API RP 2021A - Interim Study—Prevention and Suppression of Fires in Large Aboveground Atmospheric Storage Tanks. American Petroleum Institute. 1998.
- [4] Wells, G.L., Major Hazards and Their Management. Institution of Chemical Engineers, Rugby, UK. 1997.
- [5] OGP - Risk Assessment Data Directory - Storage incident frequencies. 2010, . Report No. 434-3. 2010, Available from: <http://www.ogp.org.uk/pubs/434-03.pdf>
- [6] SFPE handbook of fire protection engineering, third edition. National Fire Protection Association Society of Fire Protection Engineer, 2002.
- [7] Mansour, K. Fires in Large Atmospheric Storage Tanks and Their Effect on Adjacent Tanks, in Chemical Engineering. PhD thesis. Loughborough University. 2012.
- [8] API RP 2021 - Management of Atmospheric Storage Tank Fires. ( a technical rule) American Petroleum Institute. 2001, Availale from: <http://www.beuth.de/en/technical-rule/api-rp-2021/52283564>.
- [9] IP19 - The Institute of Petroleum: Fire Precautions at Petroleum Refineries and Bulk Storage Installations, Part 19 of the Institute of Petroleum Model Code of Safe Practice in the Petroleum Industry. Wiley, Institute of Petroleum; 1994.
- [10] Zalosh, R.G. Industrial Fire Protection Engineering. Wiley. 2003.
- [11] API 2030 - Guidelines for Application of Water Spray Systems for Fire Protection in the Petroleum Industry. American Petroleum Institute. 2005.
- [12] NFPA 30 - Flammable and Combustible Liquids Code. National Fire Protection Association. 2010.
- [13] HSG 176 : The Storage of Flammable Liquids in Tanks. HSE Books. 1998.
- [14] Lev Y, Strachan D.C. A study of cooling water requirements for the protection of metal surfaces against thermal radiation. Fire Technology. 1989; 25(3):. 213-229.
- [15] NFPA 11 - Standard for Low-, Medium-, and High-expansion Foam. National Fire Protection Association. 2005.
- [16] NFPA 15 - Standard for Water Spray Fixed Systems for Fire Protection. National Fire Protection Association. 2007.
- [17] Liu B, Fang Ye, Kaixun Wu, Mingyang W, Ming Z. The Cooling Water Intensity Design of Crude Oil Tanks Based on Standard Analysis and New Calculation Model. ICPTT. 2012; 675-84.
- [18] PNR, Spray Nozzles and Assembly Fittings, PNR, Editor. PNR.
- [19] IPS-E-SF-220 - Engineering Standard for Fire Water Distribution and Storage Facilities. Iranian Petroleum Ministry. 1993.
- [20] Rules for Water Spray Systems. Tariff Advisory Committee. 1998.
- [21] DEP 80.47.10.31-Gen. - Active Fire Protection Systems and Equipment for Onshore Facilities. SHELL. 1999.
- [22] BP Process Safety Series: Liquid Hydrocarbon Storage Tank Fires: Prevention and Response : a Collection of Booklets Describing Hazards and how to Manage Them. Institution of Chemical Engineers BP. 2005.