

A Review of Control Methods on Suppression of 2ω Ripple for Single-Phase Quasi-Z-Source Inverter

SEYFETTIN VADI¹, RAMAZAN BAYINDIR², (Senior Member, IEEE),
AND EKLAS HOSSAIN³, (Senior Member, IEEE)

¹Department of Electronics and Automation, Vocational School of Technical Sciences, Gazi University, 6170 Ankara, Turkey

²Department of Electrical and Electronics Engineering, Faculty of Technology, Gazi University, 6170 Ankara, Turkey

³Department of Electrical Engineering and Renewable Energy, Oregon Renewable Energy Center (OREC), Oregon Institute of Technology, Klamath Falls, OR 97601, USA

Corresponding author: Eklas Hossain (eklas.hossain@oit.edu)

ABSTRACT One of the disadvantages of the charging systems and voltage regulation systems in alternative energy systems is that when the direct current (DC)/alternative current (AC) or AC/DC conversion is made from the energy source, the energy flow at 2ω frequency between the direct current side and the alternative current side causes ripples in the DC, inductors, and capacitors. The ripples that occur in 2ω frequency increase the harmonic distortion and reduce the efficiency in the photovoltaic energy system. For addressing this problem, different control methods are evaluated in this paper for the elimination of ripples that occur at 2ω frequency, both on the perspective of DC control side and AC control side with a thorough comparative analysis with existing results in the literature. In the present study, the model of Single-Phase Quasi-Z Source (QZS) inverter and closed-loop control methods of the inverter are examined and compared with pulse width modulation (PWM) methods. In addition, the control methods are used to eliminate the ripples at 2ω frequency in the use of inverters, and the advantages and disadvantages of these methods are presented.

INDEX TERMS QZS inverter, suppression of 2ω ripple, control methods, pulse width modulation.

I. INTRODUCTION

With the environmental pollution stemming from fossil fuels and increased energy demand in recent years, the importance of distributed generation and renewable energy sources is increasing. After the widespread employment of renewable energy sources along with the development both in the smart grid and micro-grid structures, the studies on controlling inverter topologies are gradually being underscored. The DC/AC or AC/DC converter topologies are used widely especially in solar energy systems, due to their capability of handling wide range voltages [1]. However, the conventional converter topologies face some serious problems which need to be addressed with an efficient solution [2]. For instance, ripples occur in converter topologies at 2ω frequency causes a sudden increment in the harmonic level and decreases system efficiency. As the aftermath of ripples, the passive circuit elements and the DC windings are heated, the inverter

output voltage is distorted, and current ripples occur at low frequency at the DC side [3]. In addition, it also increases harmonic distortions and reduces the efficiency in photovoltaic energy system because it affects the monitoring of the maximum power points in such systems. In recent years, Single-Phase Quasi-Z Source (QZS) inverters are preferred because of their advantages of working in one stage, having few elements, continuous current input, and a common DC link. The number of active switches is reduced in QZS inverters compared to traditional inverters, which perform DC to AC conversion in one stage via the shoot-through modulation method. In addition, the dead time event, which occurs during the switching, is also eliminated in this respect. Due to high reliability, low harmonic levels in the output, and wide winding voltage range QZS inverters can be proved more advantageous [4], [5]. QZS inverters are used widely as modules in systems generating electricity from solar energy, in alternative current motor drives, in electric vehicles, and in cascaded inverters [6]–[9]. However, a detailed study is required to propose an efficient control method for QZS,

The associate editor coordinating the review of this manuscript and approving it for publication was N. Prabaharan¹.

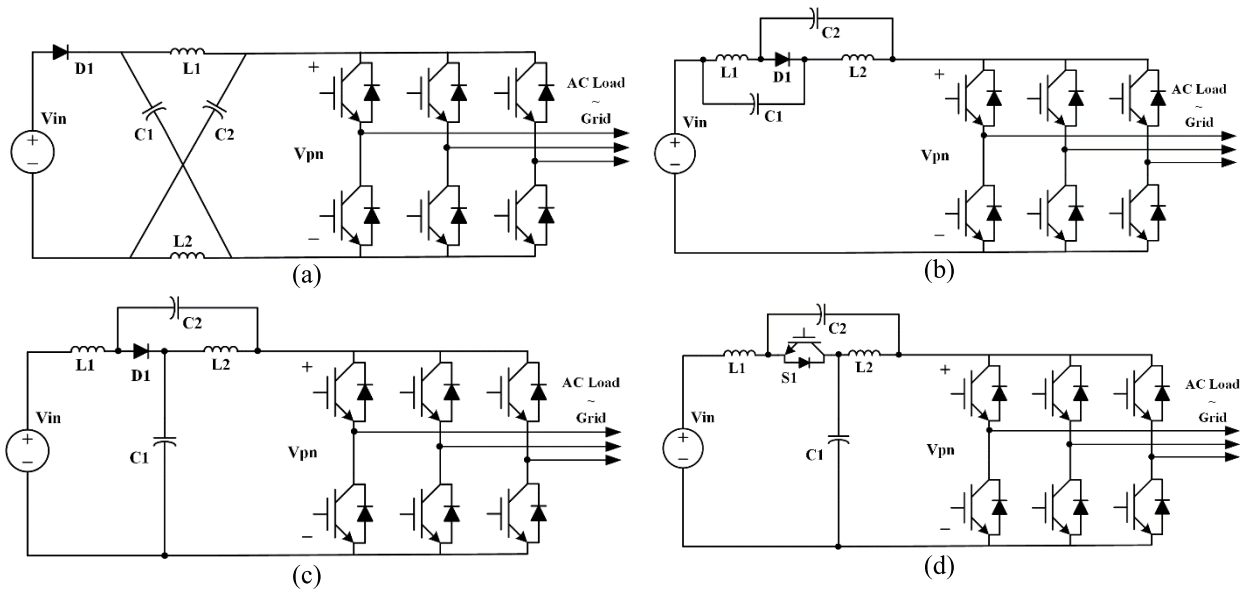

FIGURE 1. The circuit diagram of voltage-fed ZSI/QZS inverter topologies: (a) ZSI, (b) With non-continuous input voltage QZS inverter (c) With continuous input voltage QZS inverter (d) Bi-directional QZS inverter.

which needs to be further extended to analyze a suitable option for eliminating ripples at 2ω frequency. The contribution of this paper is basically focused on the topology of QZS inverter along with its mathematical modeling. Further, different control methods have been explained with the intention of finding out the viable control method for a certain application. This paper also demonstrates the impacts of different control methods for the elimination of ripples at 2ω frequency carried out in the literature and draws out a better comparative analysis which in turn proposes a better control method for suppressing the negative effects caused by the ripples in the perspective of algorithm used at both AC and DC side.

The rest of the paper is arranged as follows: Section II describes the QZS inverter topology and the mathematical model of QZS inverter is explained in Section III of this study. In Section IV, the pulse-width modulation control methods are explained for the QZS inverters. The methods used to eliminate the ripples at 2ω frequency are compared and explained in Section V. The results and detailed discussion regarding QZS are illustrated in Section VI. Finally, the paper is concluded in Section VII with a conclusion.

II. QZS INVERTER TOPOLOGY

The basis of QZS inverter is developed by improvising Z source (ZS) inverter with the intention of compensating its disadvantages [10], [11]. ZS inverter possesses the ability to convert DC to AC along with boosting up or down the voltage in a single stage [12], [13]. However, due to their characteristic of drawing up non-continuous current from the input source, they comparatively impose higher stress than QZS inverters [14]. QZS inverters have the feature that eliminates this weakness of ZS inverters and is enabled to increase and turn the voltage from direct current to alternating current

in one stage [1], [2], [15]–[17]. Moreover, the QZS inverter model is preferred because of its wide range of source voltage and fewer circuit components requirements [18]–[21]. In Fig. 1(a), the topology of the traditional voltage-fed ZS inverter is presented. Voltage source QZS inverter that has non-continuous input current are shown in Fig. 1(b), those with continuous input current are shown in Fig. 1(c), and the two-way indicator that replaces the diode (D1) with a switch (S1) is shown in Fig. 1(d). The switch (S1) utilized in Fig. 1(d) permits conduction in both ways, whereas signal blocking is unidirectional. As shown in Fig. 2, the QZS inverter topology creates shoot-through mode by triggering the lower and upper switches of the phase to increase the DC input voltage and to achieve the desired output voltage. The inverter behaves as a boost converter in shoot-through mode and acts as an inverter in non-shoot-through mode.

The inverter also reduces the voltage stress on the switches because it draws continuous current due to the L1 inductor. For this reason, it also reduces the capacity of the capacitor that is attached to the output of the solar panels [16], [22]. In traditional voltage source inverters, shoot-through mode is not used since it creates a short-circuit phenomenon in the voltage source, which may cause severe effects for the entire device. In the QZS inverter module, the operation is altered by connecting the LC and diode to the inverter bridge for providing protection from short-circuit [23]. Shoot-through mode increases the DC link voltage in the QZS inverter [24]. This feature protects the circuit effectively and increases the reliability of the circuit [25].

Feedback control compares the inverter output parameters such as voltage, current and DC link voltage with the reference parameters to produce a reference signal for the PWM control method [26], [27]. Control also constitutes

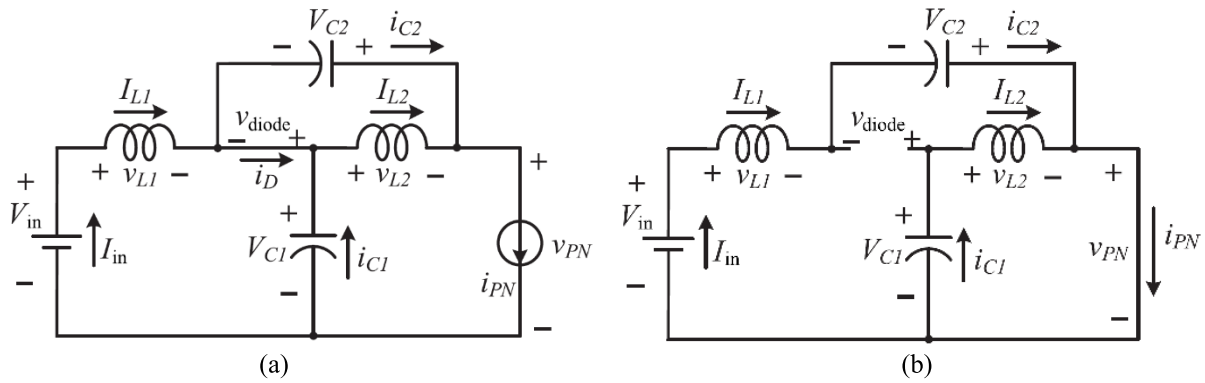

FIGURE 2. QZS inverter equality circuit (a) Non-shoot-through status (b) Shoot-through status.

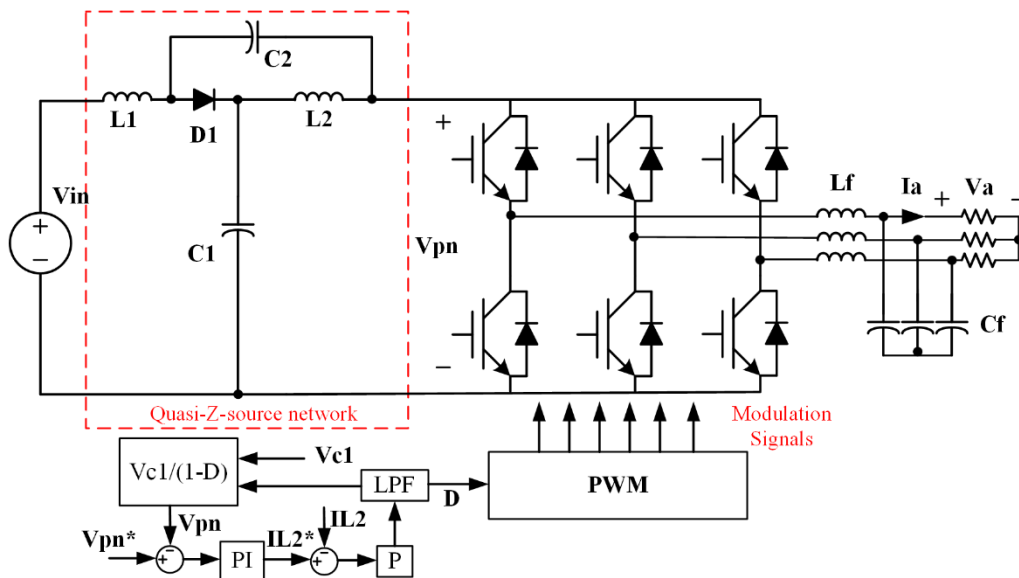

FIGURE 3. Circuit and block diagram to represent the DC side control of the QZS inverter to increase the DC voltage.

the reference value of the shoot-through from the duty cycle. This reference and the shoot-through signal generate the necessary signal for the switching of IGBTs. There are two parts to the feedback control of the QZS inverter: the first one is the control of the DC side to increase the DC voltage in the entry, and the other one is the control of the AC side where the increased DC voltage is converted to AC [25]. As seen in Fig. 3, the DC link voltage is increased by adjusting the shoot-through duty ratio (D) [28]. For this reason, the inverter output voltage increases via the DC link voltage. It is used for closed-loop feedback control with capacitor voltage (V_{C1}) [29]. The block diagram for controlling the AC side of the QZS inverter is given in Fig. 4. According to the block diagram, the DQ control method is used to control the AC side of the inverter. This method is used to convert the signals from the rotating area to the fixed plane because control is easier on a fixed plane where the network signal must be monitored with phase-locked loop (PLL) [30]–[32].

When the use of QZS inverter topology was investigated in the literature, it was determined that different additions were made to the inverter model for different purposes. For example, Jasem et al. conducted a simulation study and carried out an application for battery storage systems working in parallel with the QZS inverter in a micro-grid. The battery groups feed the load in the island mode operation of the micro-grid, and if the inverter is in shoot-through mode, power is shared at different voltage and current rates between the battery groups. The control of the unbalanced loads is ensured by sharing the current among the battery groups and by adjusting the inverter modulation index and shoot-through ratio. In this way, the harmonic level of the system is reduced to 1% [33].

A new type of topology is formed according to the connection of the battery groups to the topology. Since battery groups are used frequently for storage in photovoltaic energy sources, Dongsan et al. studied the simulation of the QZS inverter with battery for photovoltaic energy sources.

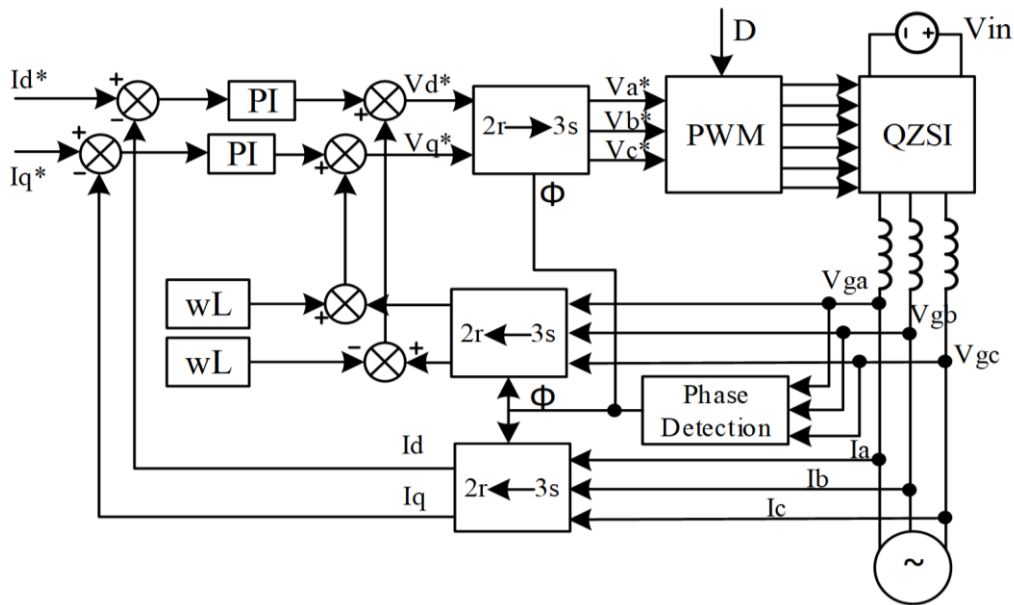

FIGURE 4. Block diagram of AC side Control of the QZS inverter to convert DC to AC.

The battery was connected parallel to one of the capacitors in the inverter. In this way, the fluctuations in both the energy that is supplied to the network and the photovoltaic energy were corrected. The control of the power flow of the photovoltaic panels was achieved via the maximum power point tracking (MPPT) algorithm that is employed on the DC side [34]. QZS inverter design is made for each parallel branch to use the proposed topology in solar fields, and cascaded multi-level inverter design is also made [35]. Umarani et al. performed the modeling and control of the cascaded multi-level inverter by using the QZS inverter for network-interactive photovoltaic energy. In this way, low-level harmonic distortion and high gain and reliability are obtained for photovoltaic systems. The ripple at 2ω frequency was minimized by calculating the size of the L and C passive elements with a formula. The MPPT algorithm was employed for DC side control, and the open loop control method was used for AC side control [36].

The QZS inverter is preferred in motor drivers because of its advantages over other topologies in present times [37], [38]. Especially its high performance under load is another reason for preference. Ping et al. proposed a model-predictive control method to decrease the thermal stress that occurs on the switches in the motor driver's structure that is designed with QZS inverter topology. The accuracy of this proposed method was proven by comparing the simulation and application of this proposed method, and it was found that the thermal stress in normal conditions was decreased 10 times [39]. In recent years, QZS inverters are preferred because of their advantages of working in one stage, having few elements, continuous current input, and a common DC link. The author controlled both the AC and DC sides of the inverter. The sliding mode control (SMC), which is

preferred to regulate the capacitor voltage on the DC side, enabled the system to respond quickly and dynamically in case of change in the input voltage and output load [40]–[42]. By comparing the Proportional Integral (PI) Control and the SMC Control, it was determined that the dynamic response of the PI control was slower. On the AC side, on the other hand, control was achieved with the current control algorithm [43], [44].

The LCL filters are preferred to correct the oscillations in the output voltage on the AC side and to ensure network connectivity when DC/AC conversion is made in QZS inverters [45]. The authors used the SMC algorithm on both the DC and AC sides and the LCL filter to minimize the 2ω ripples. They lowered the harmonic level to 1% with the help of the control algorithms [46]. In another study, the PI control algorithm was used to keep the V_{C1} capacitor voltage constant in the DC side control of the QZS inverter. The inverter fixed the DC 160V input voltage to the reference DC 250 V level at 10 kHz switching frequency. The DC link voltage was measured as 340V. The PI control parameters were determined according to the Routh-Hurwitz stability criterion, and it was determined that the inverter was stable according to the specified parameters by creating Bode response. The multi-loop Proportional Resonant (PR) control algorithm, which performs stable operation in alternative current and which is easy to control, was preferred in the AC side control of the inverter. The external voltage cycle produces reference current for the internal current loop (PR control). As a result of the study, the 3rd, 5th, 7th, and 9th harmonics were suppressed. It was ensured that the output voltage is sinusoidal for linear and nonlinear loads. In addition, high system stability level and rapid dynamic system response were also achieved. The harmonic level was found to be 1.15% [47].

QZS inverters are also used as multi-level inverters by attaching them to cascades with their powerful boost capabilities [48], [49]. Since there are no transformers in the cascade-attached H-bridge topology structure, it is also defined as the Photovoltaic inverter topology. The authors achieved an independent DC link voltage in their study by connecting QZS inverter to each solar panel. The phase shift PWM was used as the PWM control method. Unlike other multi-level inverter models, this control method decreased the current distortion connected to the network by creating a balanced DC link voltage [50].

III. MATHEMATICAL MODEL OF THE QZS INVERTER

In non-shoot through and shoot-through state, the equality circuit of the QZS inverter is given in Fig. 2. Mathematical equations were created for both working states according to the equality circuit [34], [36], [39], [43], [46]. For non-shoot-through status, inductor voltages (V_{L1} and V_{L2}), DC link voltage (V_{pn}), and diode voltage (V_D) were calculated as follows.

$$V_{L1} = V_{in} - V_{c1}, V_{L2} = -V_{c2} \quad (1)$$

$$V_{pn} = V_{c1} - V_{L2} = V_{C1} + V_{C2}, \quad V_D = 0 \quad (2)$$

Here, V_{C1} and V_{C2} are voltages across capacitor C_1 and C_2 respectively and V_{in} represents the input voltage. For shoot-through status, the mathematical equations were obtained by short-circuiting the inverter model. In this respect, inductor voltages (V_{L1} and V_{L2}), DC link voltage (V_{pn}) and diode voltage (V_D) are calculated as follows.

$$V_{L1} = V_{C2} + V_{in}, \quad V_{L2} = V_{C1} \quad (3)$$

$$V_{pn} = 0, \quad V_D = V_{C1} + V_{C2} \quad (4)$$

The equations of the average voltage of the capacitors during a switching period in a stable state are given below.

$$V_{C1} = \frac{T_1}{T_1 - T_o} * V_{in} \quad (5)$$

$$V_{C2} = \frac{T_o}{T_1 - T_o} * V_{in} \quad (6)$$

T_o refers to the duration of the shoot-through state, T_1 refers to the duration of the non-shoot-through state, and V_{in} refers to the DC input voltage. The DC link voltage of the inverter is calculated as follows.

$$V_{pn} = V_{C1} + V_{C2} = \frac{T}{T_1 - T_o} * V_{in} = B * V_{in} \quad (7)$$

T represents the switching period ($T_o + T_1$) of the QZS inverter, and B represents the boost parameter of the inverter. The average current values of the L_1 and L_2 inductor (I_{L1} and I_{L2} respectively) are calculated by using the system power.

$$I_{L1} = I_{L2} = I_{in} = \frac{P}{V_{in}} \quad (8)$$

The capacitor currents are calculated based on the Currents Law as follows.

$$I_{C1} = I_{C2} = I_{pn} - I_{L1} \quad (9)$$

The voltage gain (G) of the inverter, on the other hand, is calculated with the equation given below. M refers to the modulation index, V_{in} refers to the phase voltage of AC.

$$G = \frac{V_{in}}{0.5 * V_{pn}} = M * B \quad (10)$$

IV. REVIEW OF PWM CONTROL METHODS FOR QZS INVERTER

There are four classical carrier-based PWM methods for QZS inverter: Simple Boost Control (SBC) [2], Maximum Boost Control (MBC) [47], Maximum Constant Boost Control (MCBC) [50], and Modified Space Vector PWM (MSPWM) [51]. A new PWM method is produced by adding different shoot-through references to the traditional carrier-based PWM methods [52].

In the SBC Method, as seen in Fig. 5, two big straight lines that are equal to or bigger than the maximum value of the three-phase reference are used to control the shoot-through duty ratio in the traditional sinusoidal PWM. When the triangle waveform is bigger than the upper line (V_p) or when it is smaller than the lower line (V_n), the circuit starts the shoot-through mode. Aside from this, the SBC Method works as carrier-based traditional DGM. Although the operation of this method is simple, the voltage stress is high on the switches [53], [54]. Decreasing the voltage stress under the desired voltage gain is more important than controlling the QZS inverter [55]. This is achieved by keeping the duty ratio as wide as possible. The MBC Control method turns all the traditional zero states into shoot-through states. In Fig. 6, when the triangular carrier wave is bigger than the maximum value of the reference V_a , V_b , and V_c , or when it is smaller than the minimum value of the references, the circuit switches

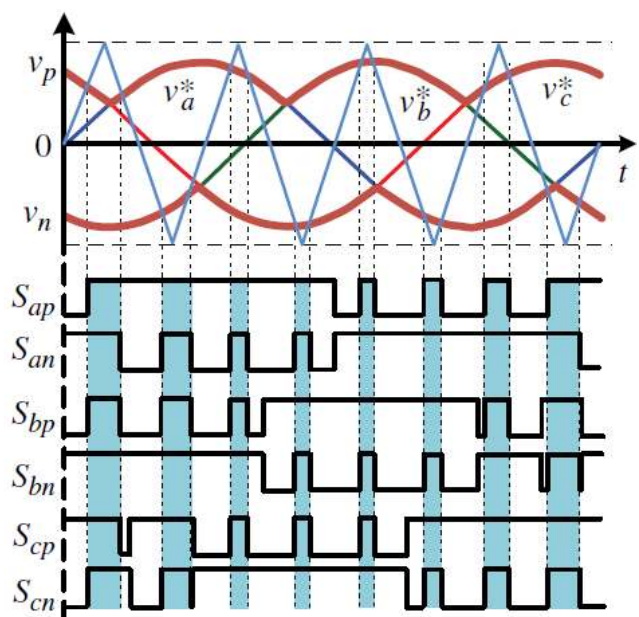

FIGURE 5. The waveform of the switching signals in Simple Boost Control.

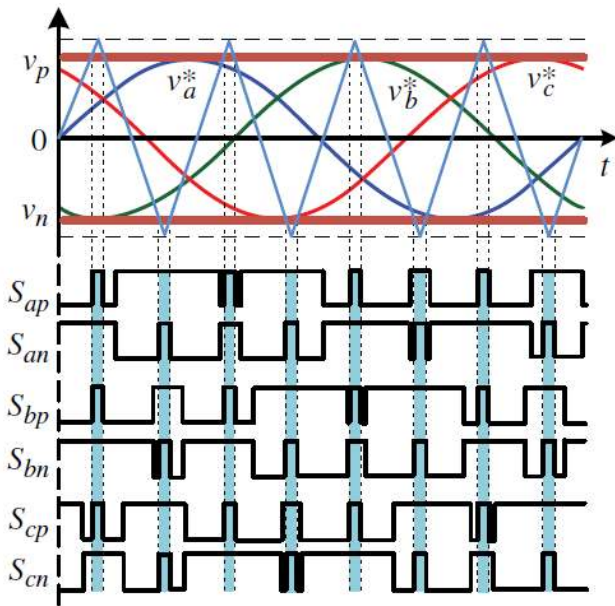

FIGURE 6. The waveform of the switching signals in Maximum Boost Control.

to shoot-through state. Shoot-through duty ratio changes the output frequency six times. The ripples in the duty ratio will also cause ripples in the inductor current and condenser voltage. When the output frequency is very low, the capacity of the passive circuit elements will increase. For this reason, the MBC method is recommended for applications that have constant and high output frequencies [56], [57]. Keeping the shoot-through duty ratio constant is always important to decrease the size and cost. Meanwhile, a maximum voltage increase is needed for any modulation index to decrease the voltage stress between the switches. The MCBC method achieves maximum voltage gain while it keeps the shoot-through duty ratio constant at all times [58]. The waveform of the maximum constant shoot-through boost control is seen in Fig. 7. Two straight lines control the V_p and V_n shoot-through control time [59], [60]. The best way to decrease the switching loss is the Space Vector PWM method. In each sector in the traditional Space Vector PWM method, as seen in Fig. 8, only one switch is changed in every range from left to right (0 to 1 or 1 to 0). The traditional SVPWM method is not applied directly to the QZS inverter. Modified SVPWM that is suitable for QZS inverter is created as the shoot-through status time by taking the zero vector time as the references.

The traditional SPWM and MSVPWM methods are given in Fig. 9. The Space Vector PWM (SVPWM) method is widely used in industrial practice because of its low harmonic level, efficiency at high voltages, and the highest modulation index [61], [62]. Unlike the traditional SVPWM, Modified Space Vector Modulation (MSVM) includes T_1 , T_2 and T_z time intervals as well as T_0 shoot-through time to increase the DC link voltage of the inverter. Shoot-through (ST) states indicate each phase in the $T_0/6$ time frame at zero voltage

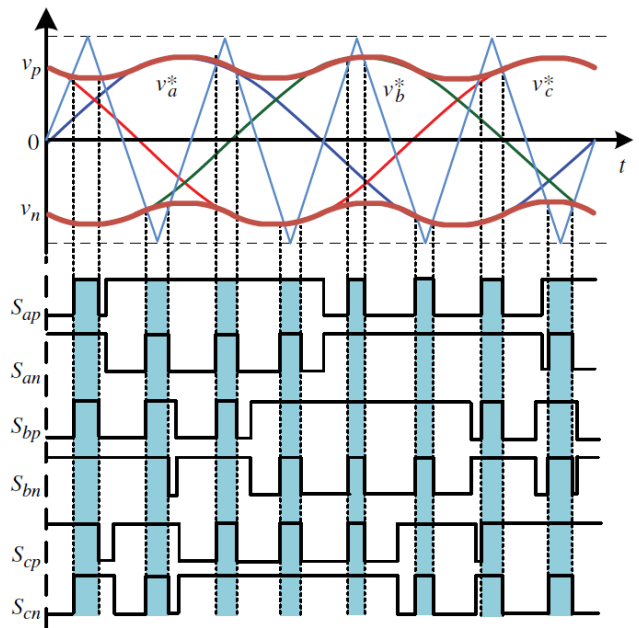

FIGURE 7. The waveform of the switching signals in Maximum Constant Shoot-through Boost Control.

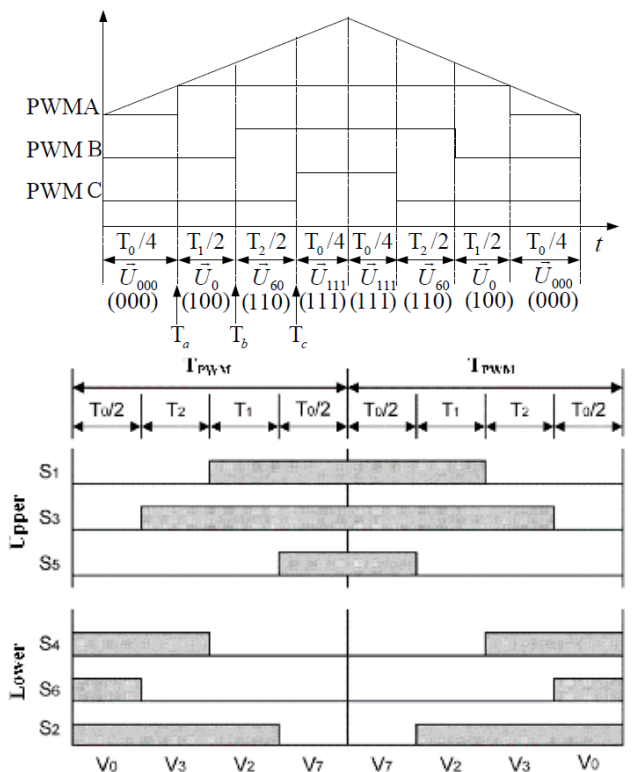

FIGURE 8. Switching Status of Traditional Space Vector PWM Method.

period (T_z). The zero voltage-time is decreased to create ST time, and T_1 and T_2 are not changed. In this way, the ST duration does not affect the PWM Control of the inverter, and T_z limits the zero state time [63], [64].

TABLE 1. Summary of different st boost control method expressions.

ST Control Methods	SBC	MBC	MCBC	MSVPWM
D_o	$1 - M$	$\frac{2\pi - 3\sqrt{3}M}{2\pi}$	$\frac{2 - \sqrt{3}M}{2}$	$\frac{3}{4} \cdot \frac{2\pi - 3\sqrt{3}M}{2\pi}$
B	$\frac{1}{2M - 1}$	$\frac{\pi}{3\sqrt{3}M - \pi}$	$\frac{1}{\sqrt{3}M - 1}$	$\frac{4\pi}{9\sqrt{3}M - 2\pi}$
G	$\frac{M}{2M - 1}$	$\frac{\pi M}{3\sqrt{3}M - \pi}$	$\frac{M}{\sqrt{3}M - 1}$	$\frac{4\pi M}{9\sqrt{3}M - 2\pi}$
M_{max}	$\frac{G}{2G - 1}$	$\frac{\pi G}{3\sqrt{3}G - \pi}$	$\frac{G}{\sqrt{3}G - 1}$	$\frac{2\pi G}{9\sqrt{3}G - 4\pi}$
V_s	$(2G - 1)V_{in}$	$\frac{3\sqrt{3}G - \pi}{\pi} V_{in}$	$(\sqrt{3}G - 1)V_{in}$	$\frac{(9\sqrt{3}G - 4\pi)}{2\pi} V_{in}$

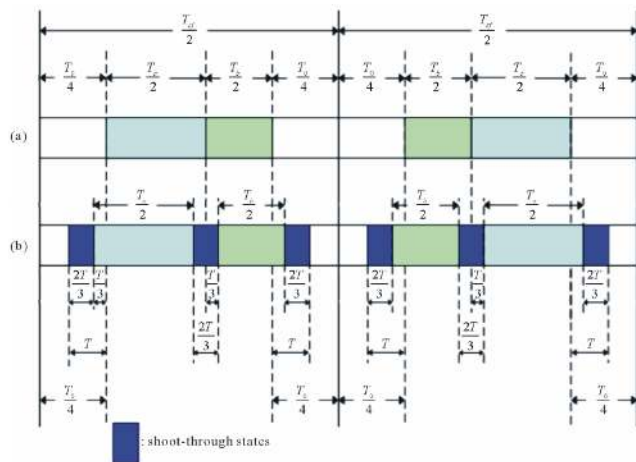

FIGURE 9. Switching signal of a) Traditional SPWM b) MSVPWM method waveform for the determination of the switching status of the inverter.

The shoot-through task ratio (D_0), boost rate (B), maximum shoot-through duty ratio (D_{max}), maximum voltage gain (G_{max}), maximum voltage stress (V_s) parameters are given for different shoot-through control methods in Table 1. In this respect, comparisons of the control method parameters are also seen [65]. The PWM methods are needed for the operation of the QZS inverters and converters [66]–[68]. The SVPWM and MBPWM shoot-through control methods have the highest maximum shoot-through ratios and voltage stresses. In addition, although the SVPWM method has the highest boost factor, its maximum voltage gain is constant [65], [69].

Input voltage (V_{in}), capacitor voltage (V_c) or DC link voltage are used as the reference to keep the DC link voltage or to create a shoot-through task ratio. The reference values

are controlled with the difference that is obtained by making comparisons with the measured values or with error PI. The I_L coil current that is obtained from the result of the PI control is controlled by comparing it with the measured I_L current with PI, and as a result of this, the shoot-through duty ratio (D) is created. Fig. 10 shows a summary of the single-loop control method. A feedback system is created with a linear method and with two nested controls [70]. In non-linear control methods input voltage (V_{in}), capacitor voltage (V_c) or DC link voltage are used as control variables, as shown in Fig. 11. These variables are controlled with Fuzzy Logic Controller, Sliding Mode Controller, Artificial Intelligence or Model-predictive methods to determine the shoot-through duty ratio [60]–[62]. The single-loop control method of the shoot-through duty ratio is given in Fig. 12. Although the command signal is the shoot-through duty ratio (D) for single-loop control, it is the inductor current for double-loop control. (I_L^*) The DC link voltage of the QZS inverter is in the form of square-wave because of the zero conditions of the shoot-through; and therefore, the measurements might be incorrect [71]. Extra sampling circuits are needed for correct measurements; however, additional circuits will also cause hardware complexity [72]. The capacitor voltages are used indirectly to control DC link voltage in QZS inverter. DC link voltage is affected directly by the changes in the DC input voltage in the single-loop control method [18], [73]. The dual-loop control method with shoot-through control with the duty ratio performs the control process as the internal and external loop, as shown in Fig. 13 [74]. The determination of DC link voltage and rapid response are ensured in the internal loop with the coil current and capacitor voltage P (Proportional) control. In the outer loop, on the other hand, the PI control method is used to enhance the stability [75].

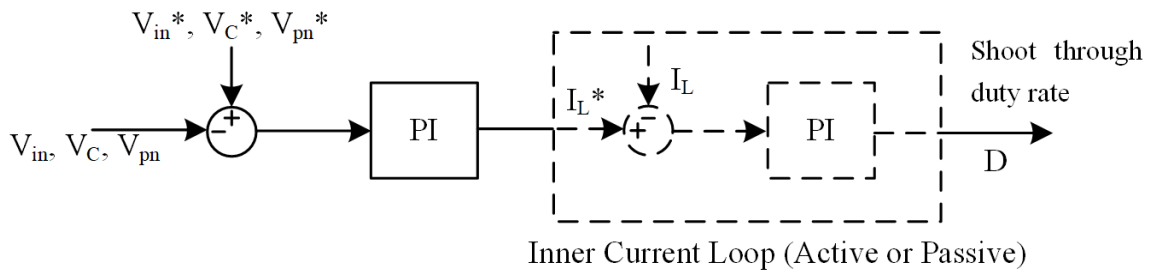

FIGURE 10. Control of the shoot-through duty ratio of the QZS inverter with PI algorithm.

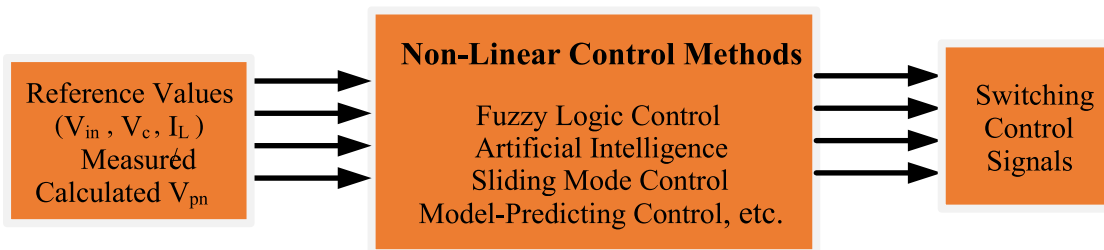

FIGURE 11. Non-linear control methods from reference voltage values with Shoot-through Control duty ratio.

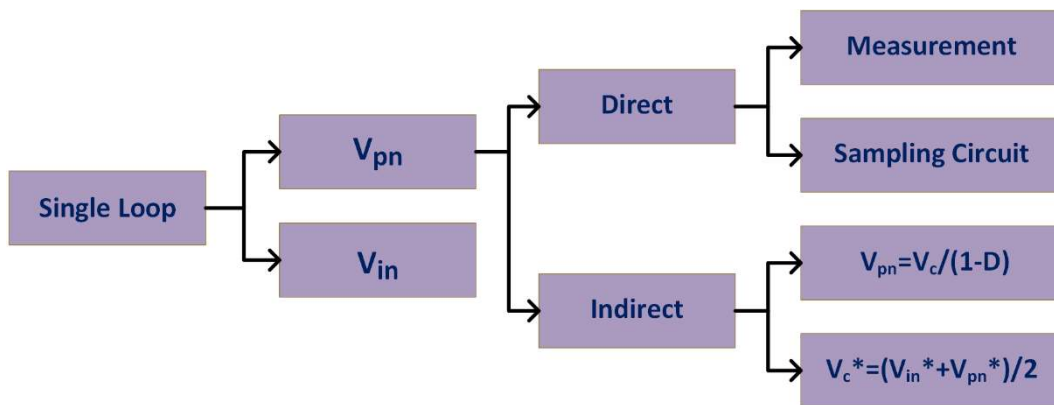

FIGURE 12. Block diagram to represent single-loop control method of the Shoot through duty ratio.

V. ELIMINATION OF RIPPLES AT 2ω FREQUENCY

At present, the disadvantages of charging and voltage regulation in alternative energy systems are that a separate DC/AC or AC/DC conversion is applied to each energy source, as shown in Fig. 14. These topologies create problems such as harmonic distortions, 2ω frequency ripples, poor voltage and current signal quality because they are used in high power and distinct input voltages. Studies in the literature provide several methods to address these disadvantages. According to the literature review, there are two methods to minimize ripples. The first one is adding additional keys to the existing topology, and the second one is to use control methods. However, it is seen that methods using control algorithms provide minimum cost and maximum efficiency.

Compared to the conventional methods, control algorithms are more effective and have low costs. Control algorithms

are used in all inverter and converter models no matter what their power electronics topologies are. It is used widely on the DC side of QZS inverter topology to eliminate or minimize 2ω frequency ripples [73]. In the control where there is no control algorithm, in other words, in passive control—extra inductor and capacitor groups are needed to suppress the low-frequency voltage ripples in the coil current and the ripples that occur at the DC side of the QZS inverter. Furthermore, these capacitors and inductor groups are more preferred in fixed power applications because their sizes vary in proportion to the power of the system. The capacitors at 2ω frequency in the energy flow between the DC and AC side, and the voltage ripples on DC link and the current ripple on the inductors heat the passive circuit elements, cause disruptions in the output voltage and decrease the efficiency in photovoltaic systems in single-phase inverter

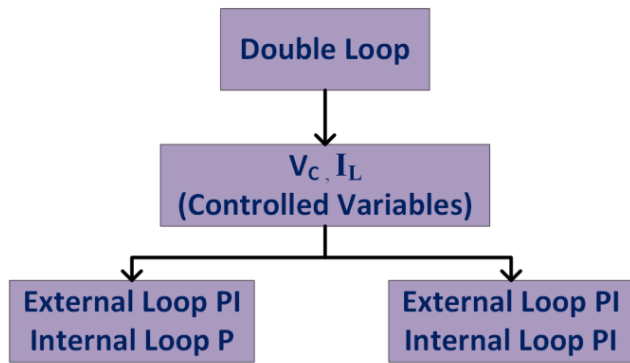

FIGURE 13. Classification of the double-loop control method with a shoot-through control duty ratio, showing two different external and internal loop.

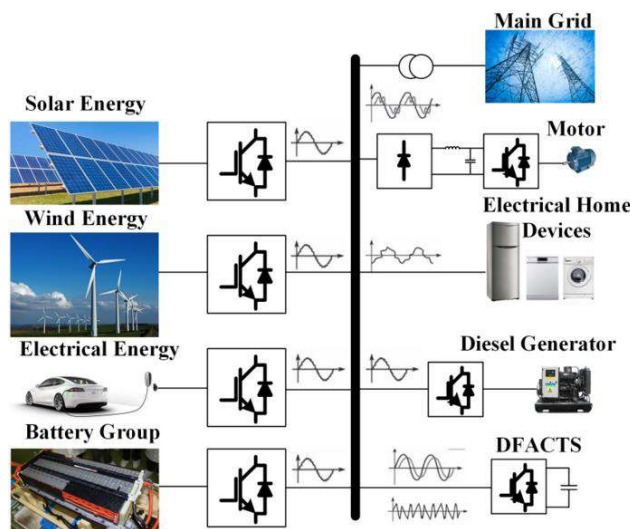

FIGURE 14. Block diagram of the topologies used in Alternative Energy Sources (left), connected to the main grid (right) through corresponding power electronics devices.

systems [76], [77]. For this reason, the 2ω ripples on the DC side must be eliminated or decreased. The simplest method to eliminate or decrease these ripples is to increase the inductor and capacitor values used in the topology [43].

Another method was proposed as a parameter design method with a dynamic photo-voltaic panel and terminal capacitors. However, these methods cause large volume and weight, together with high costs, and decrease the efficiency and reliability of the system because of their large-valued capacitors and inductors [16]. One of the methods that are employed to eliminate the ripples at 2ω frequency is the Active Power Filter method, which is preferred widely in QZS inverters to suppress the ripples in the current and voltage on the DC side [78]. In such inverters, there is an additional arm that consists of switches to activate or disable the filter circuit. In this way, the ripples in the capacitor voltage and in the inductor current on the DC side are decreased. The disadvantage of using the Active Power Filter is that the cost is high, and control is complex because of the extra circuit [79]. It is recommended in the feedback control methods to

control the ripples at 2ω frequency. To do this, the current and voltage ripples at 2ω frequency in the inductor current on the DC side with the low-pass filter were used as the reference to create the shoot-through signal [80], [81]. Another method that is employed to suppress 2ω ripples is forward control methods. In these methods, 2ω current in DC link is observed to follow the output current of the inverter [82]. Furthermore, Virtual Active Power technology is another viable option, which will increase the cost because it will require a filter or a sensor to capture the 2ω ripple component. For this reason, the relation between the 2ω ripple on the DC side, the change in the shoot-through duty ratio, and the 2ω ripples must also be suppressed without hardware.

Decreasing the modulation rate of the QZS inverter also effectively decreases the ripples on the DC side of the inverter. However, decreasing the modulation rate and increasing the shoot-through duty ratio increases the harmonic distortion in the output voltage of the inverter and the losses in the switching elements [57]. When the studies in the literature were reviewed, it was seen that there are modified new modulation methods. Different from the traditional modulation method, the shoot-through control line is modified on a 2ω component line [83]. In this respect, a new double switching frequency modulation method has been created by combining the low-frequency sinusoidal PWM and the high-frequency PWM. With this method, the relation between the shoot-through duty loop and the inverter modulation index is eliminated [84]. In addition to the use of the New Space Vector Modulation Method, the shoot-through time interval is designed according to the active and passive status of the switches to reduce the ripples in the coil current [85], [86]. In [87], the limited control-cluster model minimized the 2ω ripples in the DC side with the predictive control algorithm. In [88], a current control-based model is proposed for the ripples in the inductor and capacitor voltages on the DC side. This approach decreases the ripples in the coil current on the DC side for the QZS inverter with a single-phase, grid-connected with LCL filter and with active suppressing and constant virtual time.

The fluctuations in the 2ω frequency occur due to the imbalances in the power flow between DC and AC in DC-AC or AC-DC converters. This fluctuation occurs both in the traditional inverter models and in the QZS inverter model. In the traditional method, large-value DC link capacitors are employed to suppress this fluctuation. In their study, the authors used an Active Power Decoupling Control method by adding an extra arm to the existing single-phase QZS inverter topology. An AC capacitor and the high-frequency coil are connected in this arm. In this way, they established a second AC power line to eliminate the fluctuations. The ripples in the current and voltage on the DC side were decreased by 70% [89]. B. Ge et al. conducted a simulation and experimental study by using the method of suppressing current fluctuations to minimize the current and voltage fluctuations at 2ω frequency that is caused by the DC side of the single-phase QZS inverter system. They reported

that the results were consistent by comparing the results of both studies. The capacity and inductance sizes that were employed in the topology were minimized via preferred control method. In addition, it was also seen that the control method eliminated the ripples in the inductor current at 2ω frequency and decreased the voltage ripples that occurred in the DC link at the same frequency. The verification of the theoretical analyses, simulations, and the results obtained from experimental studies were carried out in [90]. In another study, the ripples at 2ω frequency, which caused the power imbalance between AC and DC in the inverter, were suppressed by using the Power Decoupling Control Method. The ripples in the DC link voltage were decreased by more than 50%. In the simulated study, the capacitor and inductor capacities were decreased by 1/100 by controlling the ripples [91].

In the present study, by minimizing the ripples at 2ω frequency with the recommended control algorithm without employing any passive circuit or switching elements, the system efficiency was increased. The DC side of the inverter was realized by employing the PI Control Method, and the AC side by using the SMC method. The efficiency of the system was calculated to be 90% with the control method. With the help of the SMC on the AC side, the stable state error was eliminated [92]. The ripples at 2ω frequency on the DC side can be eliminated by adding additional filters to the inverter structure. The authors proposed a single-phase QZS inverter model that was combined with an active filter to avoid the ripples at 2ω frequency in their study. They conducted the analysis of the inverter, its parameter design, topology and modeling of the active filter in their study. As a result of their study, the ripples in the current and voltage signals were eliminated, and the system efficiency was increased to 90.49% [93]. The authors applied a model-predictive control method to the QZS inverter model with active power filters in their study and eliminated the ripples at 2ω frequency. They created a new topology by adding an active power filter to the single-phase system. Most of the fluctuations at 2ω frequency that occurs on the DC side was suppressed with an active power filter that was attached to the AC side [94]. The authors reduced the ripples at 2ω frequency in the photovoltaic systems between DC input and AC output by using film converters in their study. They obtained both experimental and practical results by using MPPT on the DC side and PI and PR control methods on the AC side [95]. In their study, the authors proposed a new modulation strategy by using Ripple Vector Cancellation method to eliminate the ripples on the current at 2ω frequency coil and on the voltage on the capacitor. This modulation method works according to the principle of measuring the change ratio at the shoot-through duty ratio at 2ω frequency and adding this changing ratio to the fixed shoot-through duty ratio. This method was compared with the traditional modulation method. In this respect, the current ripple at 2ω frequency on the DC side decreased to 1.69% from 40.15%, and the voltage ripple at the same frequency decreased to 7.75% from 9.40%. In addition,

there are significant decreases in capacitor and coil sizes compared to the traditional modulation method [96].

The studies in the literature conducted with QZS inverter topology to suppress or minimize the current and voltage fluctuations at 2ω frequency are summarized in Table 2. As it may be seen in this table, the inverter is used with a single-phase network in an interactive manner in general. It is seen that the modulation index is selected between 0.0 and 0.8. A direct current source is preferred as the input source of the inverter. The voltage of the source is between $40 V_{DC}$ and $200 V_{DC}$. In addition, solar panels are also used as the source of input in the inverter. In general, the switching frequency of the topology was preferred as 10 kHz, and the SPWM Method was used as the PWM method. The SPWM Method is more preferred because it is simple and easy when compared to the other PWM methods [97]. The control methods, which are used as the method of eliminating or minimizing the fluctuations at 2ω frequency, and the effect of these methods on the current and voltage fluctuations are given in Table 1. The control method, which eliminates this negative effect, is the most successful one. The simulations and applications of the inverter model are given comparatively in studies. In this way, the theory of the system in the simulation environment and its work in actual application settings are given together to show the consistency of the study.

VI. RESULTS AND DISCUSSIONS

In this current study, the QZS inverter topology, which has the ability to decrease/increase voltage in one stage and convert voltage from direct current to alternating current, was examined. Since this topology is derived from ZSI topology, a new topology has been created with the positive attributes of Z-source inverter topology by eliminating or improving its negative aspects. ZSI topology has several drawbacks such as being insufficient in providing constant current in a photovoltaic system, lacking weld voltage in a wide range, having more circuit components, and high source stress. QZS inverter topology has high reliability and can lower or raise the voltage in one stage with the continuous input current. It performs converter and inverter operation with fewer circuit elements compared to the other topologies that are employed in the literature. QZS inverters have a reduced number of active switches when compared to traditional inverters, and perform DC-AC conversion in one stage via the shoot-through modulation method. In addition, the dead time that is created during switching disappears. It is used widely in photovoltaic energy systems because it provides continuous current.

The disadvantage of QZS inverter is the ripples in the current at 2ω frequency coil on the DC side and the voltage fluctuations in the capacitor. This negative situation causes that the harmonic level and stress are increased on the switches. In addition, disruptions occur in the DC link voltage and inverter output voltage. Additional hardware structure or control methods are employed to eliminate the negative aspects of the QZS inverter. Extra inductor and capacitor

TABLE 2. Summary of the studies in the literature to suppress the current and voltage fluctuations at 2ω frequency.

Topology	Working Mode	Modulation	V_{DC}	Switching Frequency	PWM Method	Control Method	Working Type	Explanation	Ref.
Quasi-Z Source Inverter	Single-Phase- Network Interaction	-	40 V - Solar Panel	-	SPWM	Active Power Decoupling Method	Simulation and Application	The ripples at 2ω frequency that occurred in entry voltage were eliminated by 70%, and the capacity was decreased on the DC side by 87.5%.	[89]
Quasi-Z Source Inverter	Three-Phase Island mode	0.6	85 V - Voltage Source	10 kHz	SPWM	Current Ripple Decoupling Control	Simulation and Application	The ripples at 2ω frequency that occurred in coil current were eliminated, and the voltage ripples on DC link was 5%.	[90]
Quasi-Z Source Inverter	Single-Phase - Network Interaction	0.8	80 V - Voltage Source	10 kHz	SPWM	Automatic Power Decoupling Control Method	Simulation	The ripples at 2ω frequency and the ripples in the DC link voltage were decreased by more than 50% by using the Power Decoupling Control Method.	[91]
Quasi-Z-Source NPC Inverter	Single-Phase - Network Interaction	-	200 V - Voltage Source	2.5 kHz	SPWM	PI and Sliding Mode Control	Simulation and Application	The DC tars of the inverter were achieved with PI Control Method and the AC side was carried out by using the Sliding Mode Control Method. The efficiency of the system was measured to be 90% with the Control Method.	[92]
Quasi-Z-Source	Single-Phase - Network Interaction	0.6	85 V - Voltage Source	10 kHz	SPWM	Power Decoupling Control Method	Simulation		[93]

TABLE 2. (Continued) Summary of the studies in the literature to suppress the current and voltage fluctuations at 2ω frequency.

Quasi-Z-Source	Single-Phase - Network Interaction	0.6	85 V - Voltage Source	10 kHz	SPWM	Model-Predictive Control Method	Simulation	The coil and capacitor values decreased at a rate of 92.2% and 88.6%, respectively.	[94]
Quasi-Z-Source	Single-Phase - Network Interaction	0.6	140 V - PV	10 kHz	SPWM	PI and Model-Predictive Control Method	Simulation and Application	Capacity was decreased with the help of the control method, and 2uF was used instead of the 200uF capacitor. The efficiency of the system was increased by 70%.	[95]
Quasi-Z-Source Inverter	Single-phase - Island mode	0.7	60 V - Voltage Source	10 kHz	Ripple Vector Cancellation-based Modulation Method	Ripple Vector Cancellation Method	Simulation and Application	With the help of the preferred method, the ripples at 2ω frequency in the coil current on the DC side were minimized, and the voltage ripples at 2ω frequency were not affected much.	[96]

groups are required in the additional equipment structure. This method, which is used as passive control is more preferred in fixed power applications because the sizes of the capacitors and coil groups vary in proportion to the power of the system. However, the sizes of the capacitors and coil groups, which increase according to the power of the system, increase the cost of the system and the complexity of the control and the inverter size. In the Active Control Method, which uses the additional equipment structure, there is an additional arm that consists of switches to activate or deactivate the capacitors and inductor components. In addition to the negative aspects of the switch-free control, the harmonic level is increasing because of the increase in the number of the keys, and the difficulty of the system control is increasing.

Control methods that are employed to minimize or eliminate the fluctuations at 2ω frequency without using passive circuit or switching elements in QZS inverter are less cost-effective compared to hardware control methods, and give the system the ability to be dynamic and have a smaller size. Although the current fluctuation suppression method

eliminates the ripples at 2ω frequency of the coil current, it decreases the voltage ripples that occur in the DC link at the same frequency. The Power Decoupling Control method reduced the ripples in DC link voltage by more than 50% and decreased the capacitor and coil capacities by 1/100. In the control carried out at the DC side of the inverter with PI Control Method and the AC side with the SMC method, the efficiency of the system was increased to 90%, and the stable state error was eliminated via the SMC on the AC side. In the control that was carried out with the Model-Predicted Control Method and Active Power Filter together, it was ensured that the ripples at 2ω frequency were eliminated. It is seen that the Active Power Filter, which is connected to the AC side, eliminated most of the ripples. The Ripple Vector Cancellation Control method, on the other hand, decreased the current ripples at 2ω frequency on the DC side to 1.69% from 40.15% and decreased the voltage ripples at the same frequency to 7.75% from 9.40%. In addition, it significantly reduced the size of the capacitor and the coil when compared to the Traditional Modulation Method.

Although the operation of the SBC switching method is simple, the voltage stress is high on the switches. In the MBC switching method, on the other hand, the ripples in the duty ratio will also cause ripples in the coil current and capacitor voltage. When the output frequency is too low, the capacity of the passive circuit elements will increase. For this reason, the MBC method is recommended for applications that have constant and high output frequencies. The MBBC method keeps the shoot-through duty ratio constant at all times and achieves maximum voltage gain. The space vector PWM method is used widely in industrial practice because of its low harmonic level, efficiency at high voltages, and the highest modulation index. However, the SVPWM method is not applied to the QZS inverter directly. It is necessary that QZS inverter appropriately-modified SVPWM is created taking the zero vector time as the reference. The SVPWM method has the highest maximum shoot-through ratio and voltage stress like the MBPWM method. In the Single-Loop Control method, the DC link voltage is directly affected by the changes in the DC input voltage [98], [99]. In this way, because of the zero states of shoot-through, it has a square-wave shape, and the measurement can be incorrect. An extra sampling circuit is needed to measure the DC link voltage accurately. However, increasing the number of circuits will make control more complex. In the double-loop, the DC-link voltage and system stability are high due to the PI control method in the internal and external loops. When the literatures were reviewed, it was determined that the use of Active Control method, Algorithm Control or hybrid algorithms on the DC and AC side were recommended to minimize the fluctuations at 2ω frequency in QZS inverter. In this method, the distortions on the output of the inverter and in the DC link will be corrected. Keeping the shoot-through duty ratio constant is always important to reduce the size and cost. It is also important to select the modulation index as a large value to reduce the voltage stress between the switches [100]. High shoot-through duty ratio will ensure that the DC link voltage is high; and therefore, the inverter output voltage will also be high. For this reason, an appropriate PWM Method must be selected.

VII. CONCLUSION

This paper has presented the topology of QZS inverter with corresponding mathematical modeling and has explained the related advantages along with some challenges regarding the effect of ripples generated at 2ω frequency. The challenge has been considered as major motivation for performing this research. Different control methods have been evaluated in this research to determine the most appropriate solution. The impacts of different control methods and as well as their effects on ripples and different switching models have been studied meticulously. A detail comparative analysis has been drawn to propose the most viable option of control methods for suppressing ripples at 2ω frequency. For certain applications, the analysis of this study can be used fruitfully as it covers all possible positive and negative effects introduced

by different control methods to utilize QZS inverter more significantly than ever. The efficacy of different control algorithms has been presented on the basis of their performances on reducing ripples, harmonic levels and voltage gain. It is clearly depicted from this research that, QZS inverter can be utilized profoundly for addressing all negative effects introduced by conventional converters and can become state-of-the-art to be implemented in renewable power systems as well as in diverged applications.

REFERENCES

- [1] Y. Li, J. Anderson, F. Z. Peng, and D. Liu, "Quasi-Z-Source inverter for photovoltaic power generation systems," in *Proc. 24th Annu. IEEE Appl. Power Electron. Conf. Expo.*, Feb. 2009, pp. 918–924.
- [2] J. Anderson and F. Z. Peng, "A class of quasi-Z-source inverters," in *Proc. IEEE Ind. Appl. Soc. Annu. Meeting*, Oct. 2008, pp. 1–7.
- [3] Q.-C. Zhong, W.-L. Ming, X. Cao, and M. Krstic, "Control of ripple eliminators to improve the power quality of DC systems and reduce the usage of electrolytic capacitors," *IEEE Access*, vol. 4, pp. 2177–2187, 2016, doi: [10.1109/ACCESS.2016.2561269](https://doi.org/10.1109/ACCESS.2016.2561269).
- [4] A. Lashab, D. Sera, and J. M. Guerrero, "A low-computational high-performance model predictive control of single phase battery assisted quasi Z-source PV inverters," in *Proc. 10th Int. Conf. Power Electron. ECCE Asia (ICPE-ECCE Asia)*, 2019, pp. 1873–1878.
- [5] Y. R. Kaffle, S. U. Hasan, and G. E. Town, "Quasi-Z-source based bidirectional DC-DC converter and its control strategy," *Chin. J. Electr. Eng.*, vol. 5, no. 1, pp. 1–9, Mar. 2019, doi: [10.23919/CJEE.2019.000001](https://doi.org/10.23919/CJEE.2019.000001).
- [6] A. Battiston, E.-H. Miliani, S. Pierfederici, and F. Meibody-Tabar, "Efficiency improvement of a Quasi-Z-Source inverter-fed permanent-magnet synchronous machine-based electric vehicle," *IEEE Trans. Transport. Electrific.*, vol. 2, no. 1, pp. 14–23, Mar. 2016, doi: [10.1109/TTE.2016.2519349](https://doi.org/10.1109/TTE.2016.2519349).
- [7] Y. Chen, W. Jiang, Y. Zheng, and G. He, "EMI suppression of high-frequency isolated quasi Z-source inverter based on multi-scroll chaotic PWM modulation," *IEEE Access*, vol. 7, pp. 146198–146208, 2019, doi: [10.1109/ACCESS.2019.2946233](https://doi.org/10.1109/ACCESS.2019.2946233).
- [8] R. A. Guisso, A. M. S. S. Andrade, H. L. Hey, and M. L. da S. Martins, "Grid-tied single source quasi-Z-source cascaded multilevel inverter for PV applications," *Electron. Lett.*, vol. 55, no. 6, pp. 342–343, Mar. 2019.
- [9] S. Hu, Z. Liang, D. Fan, and X. He, "Hybrid ultracapacitor-battery energy storage system based on quasi-Z-source topology and enhanced frequency dividing coordinated control for EV," *IEEE Trans. Power Electron.*, vol. 31, no. 11, pp. 7598–7610, Nov. 2016, doi: [10.1109/TPEL.2016.2518749](https://doi.org/10.1109/TPEL.2016.2518749).
- [10] A. Ahmad, V. K. Bussa, R. K. Singh, and R. Mahanty, "Switched-boost-modified Z-source inverter topologies with improved voltage gain capability," *IEEE J. Emerg. Sel. Topics Power Electron.*, vol. 6, no. 4, pp. 2227–2244, Dec. 2018.
- [11] V. Jagan, J. Kotturu, and S. Das, "Enhanced-boost quasi-Z-source inverters with two-switched impedance networks," *IEEE Trans. Ind. Electron.*, vol. 64, no. 9, pp. 6885–6897, Sep. 2017, doi: [10.1109/TIE.2017.2688964](https://doi.org/10.1109/TIE.2017.2688964).
- [12] S. A. Singh, G. Carli, N. A. Azeez, and S. S. Williamson, "Modeling, design, control, and implementation of a modified Z-source integrated PV/grid/EV DC charger/inverter," *IEEE Trans. Ind. Electron.*, vol. 65, no. 6, pp. 5213–5220, Jun. 2018, doi: [10.1109/TIE.2017.2784396](https://doi.org/10.1109/TIE.2017.2784396).
- [13] T. Li and Q. Cheng, "A comparative study of Z-source inverter and enhanced topologies," *China Electrotech. Soc. Trans. Electr. Mach. Syst.*, vol. 2, no. 3, pp. 284–288, Sep. 2018, doi: [10.30941/CESTEMS.2018.00035](https://doi.org/10.30941/CESTEMS.2018.00035).
- [14] X. Zhu, B. Zhang, and D. Qiu, "A new nonisolated quasi-Z-source inverter with high voltage gain," *IEEE J. Emerg. Sel. Topics Power Electron.*, vol. 7, no. 3, pp. 2012–2028, Sep. 2019, doi: [10.1109/JESTPE.2018.2873805](https://doi.org/10.1109/JESTPE.2018.2873805).
- [15] M. K. Kazimierczuk, "Small-signal modeling of open-loop PWM Z-source converter by circuit-averaging technique," *IEEE Trans. Power Electron.*, vol. 28, no. 3, pp. 1286–1296, Mar. 2013.
- [16] Y. Li, S. Jiang, J. G. Cintron-Rivera, and F. Z. Peng, "Modeling and control of quasi-Z-source inverter for distributed generation applications," *IEEE Trans. Ind. Electron.*, vol. 60, no. 4, pp. 1532–1541, Apr. 2013.

- [17] M. M. Haji-Esmaili, E. Babaei, and M. Sabahi, "High step-up quasi-Z source DC-DC converter," *IEEE Trans. Power Electron.*, vol. 33, no. 12, pp. 10563–10571, Dec. 2018, doi: [10.1109/TPEL.2018.2810884](https://doi.org/10.1109/TPEL.2018.2810884).
- [18] Y. Liu, B. Ge, F. J. T. E. Ferreira, A. T. de Almeida, and H. Abu-Rub, "Modeling and SVPWM control of quasi-Z-source inverter," in *Proc. 11th Int. Conf. Electr. Power Quality Utilisation*, Oct. 2011, pp. 1–7.
- [19] Y. P. Siwakoti, F. Z. Peng, F. Blaabjerg, P. C. Loh, and G. E. Town, "Impedance-source networks for electric power conversion part I: A topological review," *IEEE Trans. Power Electron.*, vol. 30, no. 2, pp. 699–716, Feb. 2015.
- [20] Y. Liu, H. Abu-Rub, B. Ge, F. Blaabjerg, O. Ellabban, and P. C. Loh, *Impedance Source Power Electronic Converters*. Hoboken, NJ, USA: Wiley, 2016.
- [21] S. Dong and Q. Zhang, "CCM and DCM analysis of ASC-qZSIs," *IET Power Electron.*, vol. 12, no. 8, pp. 2049–2057, Jul. 2019, doi: [10.1049/iet-pel.2018.6049](https://doi.org/10.1049/iet-pel.2018.6049).
- [22] D. Sun, B. Ge, W. Liang, H. Abu-Rub, and F. Z. Peng, "An energy stored quasi-Z-source cascade multilevel inverter-based photovoltaic power generation system," *IEEE Trans. Ind. Electron.*, vol. 62, no. 9, pp. 5458–5467, Sep. 2015.
- [23] J. Cuenot, S. Zaim, B. Nahid-Mobarakeh, S. Pierfederici, E. Monmasson, R. Meuret, and F. Meibody-Tabar, "Overall size optimization of a high-speed starter using a Quasi-Z-Source inverter," *IEEE Trans. Transport. Electrification*, vol. 3, no. 4, pp. 891–900, Dec. 2017, doi: [10.1109/TTE.2017.2738022](https://doi.org/10.1109/TTE.2017.2738022).
- [24] K. H. Law, "An effective voltage controller for quasi-Z-source inverter-based STATCOM with constant DC-link voltage," *IEEE Trans. Power Electron.*, vol. 33, no. 9, pp. 8137–8150, Sep. 2018, doi: [10.1109/TPEL.2017.2772309](https://doi.org/10.1109/TPEL.2017.2772309).
- [25] Y. Liu, B. Ge, H. Abu-Rub, H. Sun, F. Z. Peng, and Y. Xue, "Model predictive direct power control for active power decoupled single-phase quasi-Z-source inverter," *IEEE Trans. Ind. Informat.*, vol. 12, no. 4, pp. 1550–1559, Aug. 2016.
- [26] A. Vazquez Sieber, H. Haimovich, and M. E. Romero, "Control-oriented modelling and adaptive control of a single-phase quasi-Z-source inverter," in *Proc. 39th Annu. Conf. IEEE Ind. Electron. Soc. (IECON)*, Nov. 2013, pp. 572–577, doi: [10.1109/IECON.2013.6699198](https://doi.org/10.1109/IECON.2013.6699198).
- [27] J. Wang, C. Zhang, S. Li, J. Yang, and Q. Li, "Finite-time output feedback control for PWM-based DC-DC buck power converters of current sensorless mode," *IEEE Trans. Control Syst. Technol.*, vol. 25, no. 4, pp. 1359–1371, Jul. 2017, doi: [10.1109/TCST.2016.2613966](https://doi.org/10.1109/TCST.2016.2613966).
- [28] T. Kayiranga, H. Li, X. Lin, Y. Shi, and H. Li, "Abnormal operation state analysis and control of asymmetric impedance network-based quasi-Z-source PV inverter (AIN-qZSI)," *IEEE Trans. Power Electron.*, vol. 31, no. 11, pp. 7642–7650, Nov. 2016, doi: [10.1109/TPEL.2016.2515995](https://doi.org/10.1109/TPEL.2016.2515995).
- [29] R. CHENG, G. ZHAO, and T. GUO, "State feedback control strategy of Z-source inverter," *Electr. Mach. Control*, vol. 5, no. 13, pp. 673–678, 2009.
- [30] M. von Zimmermann, M. Lechler, and B. Piepenbreier, "Z-source drive inverter using modified SVPWM for low output voltage and regenerating operation," in *Proc. 13th Eur. Conf. Power Electron. Appl.*, 2009, pp. 1–10.
- [31] L. Tingyuan, Z. Jianyong, and Y. Jun, "Study on a modified space vector PWM technique based on Z-source inverter," *Telecom Power Technol.*, vol. 26, no. 5, pp. 1–5, 2009.
- [32] Y. Li, F. Z. Peng, J. G. Cintron-Rivera, and S. Jiang, "Controller design for quasi-Z-source inverter in photovoltaic systems," in *Proc. IEEE Energy Convers. Congr. Expo.*, Sep. 2010, pp. 3187–3194.
- [33] J. Khajepour, M. Hamzeh, K. Sheshyekani, and E. Afjei, "Modeling and control of quasi Z-source inverters for parallel operation of battery energy storage systems: Application to microgrids," *Electr. Power Syst. Res.*, vol. 125, pp. 164–173, Aug. 2015.
- [34] D. Sun, B. Ge, D. Bi, and F. Z. Peng, "Analysis and control of quasi-Z source inverter with battery for grid-connected PV system," *Int. J. Electr. Power Energy Syst.*, vol. 46, pp. 234–240, Mar. 2013.
- [35] M.-K. Nguyen, Y.-C. Lim, and S.-J. Park, "A comparison between single-phase quasi-Z-source and quasi-switched boost inverters," *IEEE Trans. Ind. Electron.*, vol. 62, no. 10, pp. 6336–6344, Oct. 2015, doi: [10.1109/TIE.2015.2424201](https://doi.org/10.1109/TIE.2015.2424201).
- [36] D. Umarani and R. Seyezhai, "Modeling and control of quasi-Z-source cascaded H-bridge multilevel inverter for grid connected photovoltaic systems," *Energy Procedia*, vol. 90, pp. 250–259, Dec. 2016.
- [37] F. Yi and W. Cai, "A quasi-Z-source integrated multiport power converter as switched reluctance motor drives for capacitance reduction and wide-speed-range operation," *IEEE Trans. Power Electron.*, vol. 31, no. 11, pp. 7661–7676, Nov. 2016, doi: [10.1109/TPEL.2016.2521351](https://doi.org/10.1109/TPEL.2016.2521351).
- [38] Q. Lei, D. Cao, and F. Zheng Peng, "Novel loss and harmonic minimized vector modulation for a current-fed quasi-Z-source inverter in HEV motor drive application," *IEEE Trans. Power Electron.*, vol. 29, no. 3, pp. 1344–1357, Mar. 2014, doi: [10.1109/TPEL.2013.2260173](https://doi.org/10.1109/TPEL.2013.2260173).
- [39] P. Liu, H. Wang, Y. Liu, and F. Blaabjerg, "Thermal stress reduction of quasi-Z source inverter drive by model predictive control," *Microelectron. Rel.*, vols. 88–90, pp. 1247–1250, Sep. 2018.
- [40] F. Bagheri, H. Komurcugil, O. Kukrer, N. Guler, and S. Bayhan, "Multi-input multi-output based sliding-mode controller for single-phase quasi-Z-source inverters," *IEEE Trans. Ind. Electron.*, p. 1, 2019.
- [41] M. A. Qureshi, I. Ahmad, and M. F. Munir, "Double integral sliding mode control of continuous gain four quadrant quasi-Z-source converter," *IEEE Access*, vol. 6, pp. 77785–77795, 2018, doi: [10.1109/ACCESS.2018.2884092](https://doi.org/10.1109/ACCESS.2018.2884092).
- [42] V. Utkin, "Discussion aspects of high-order sliding mode control," *IEEE Trans. Autom. Control*, vol. 61, no. 3, pp. 829–833, Mar. 2016, doi: [10.1109/TAC.2015.2450571](https://doi.org/10.1109/TAC.2015.2450571).
- [43] U. K. Shinde, S. G. Kadwane, S. P. Gawande, M. J. B. Reddy, and D. K. Mohanta, "Sliding mode control of single-phase grid-connected quasi-Z-source inverter," *IEEE Access*, vol. 5, pp. 10232–10240, 2017.
- [44] C. Restrepo, T. Konjedic, F. Flores-Bahamonde, E. Vidal-Idiarte, J. Calvente, and R. Giral, "Multisampled digital average current controls of the versatile buck-boost converter," *IEEE J. Emerg. Sel. Topics Power Electron.*, vol. 7, no. 2, pp. 879–890, Jun. 2019, doi: [10.1109/JESTPE.2018.2888980](https://doi.org/10.1109/JESTPE.2018.2888980).
- [45] Y. Shi, T. Kayiranga, Y. Li, and H. Li, "Exploring the LCL characteristics in GaN-based single-L quasi-Z-source grid-tied inverters," *IEEE Trans. Ind. Electron.*, vol. 64, no. 10, pp. 7758–7768, Oct. 2017, doi: [10.1109/TIE.2017.2694379](https://doi.org/10.1109/TIE.2017.2694379).
- [46] F. Bagheri, H. Komurcugil, and O. Kukrer, "Modified MIMO sliding-mode controller with constant switching frequency for grid-connected LCL-filtered quasi-Z-source inverter," in *Proc. 44th Annu. Conf. IEEE Ind. Electron. Soc. (IECON)*, Oct. 2018, pp. 3889–3894.
- [47] A. Ayad, M. Hashem, C. Hackl, and R. Kennel, "Proportional-resonant controller design for quasi-Z-source inverters with LC filters," in *Proc. 42nd Annu. Conf. IEEE Ind. Electron. Soc. (IECON)*, Oct. 2016, pp. 3558–3563.
- [48] F. A. Khera, C. Klumpner, and P. W. Wheeler, "New modulation scheme for bidirectional qZS modular multi-level converters," *J. Eng.*, vol. 2019, no. 17, pp. 3836–3841, Jun. 2019, doi: [10.1049/joe.2018.8020](https://doi.org/10.1049/joe.2018.8020).
- [49] W. Liang, Y. Liu, B. Ge, and X. Wang, "DC-link voltage balance control strategy based on multidimensional modulation technique for quasi-Z-source cascaded multilevel inverter photovoltaic power system," *IEEE Trans. Ind. Informat.*, vol. 14, no. 11, pp. 4905–4915, Nov. 2018, doi: [10.1109/TII.2018.2863692](https://doi.org/10.1109/TII.2018.2863692).
- [50] L. Yi, Q. Gui, and Z. Wang, "A novel quasi-Z source cascaded multilevel photovoltaic power system applied to smart microgrid," in *Proc. 10th Asia-Pacific Power Energy Eng. Conf. (APPEEC)*, Jun. 2018, pp. 34–42.
- [51] W. Liang, B. Ge, Y. Liu, H. Abu-Rub, R. S. Balog, and Y. Xue, "Modeling, analysis, and impedance design of battery energy stored single-phase quasi-Z source photovoltaic inverter system," in *Proc. IEEE Energy Convers. Congr. Expo. (ECCE)*, Milwaukee, WI, USA, 2016, pp. 1–6.
- [52] C. Roncero-Clemente, E. Romero-Cadaval, M. Ruiz-Cortes, and O. Husev, "Carrier level-shifted based control method for the PWM 3L-T-Type qZS inverter with capacitor imbalance compensation," *IEEE Trans. Ind. Electron.*, vol. 65, no. 10, pp. 8297–8306, Oct. 2018, doi: [10.1109/TIE.2018.2814020](https://doi.org/10.1109/TIE.2018.2814020).
- [53] H. Zhang, Y. Liu, D. Sun, B. Ge, H. Abu-Rub, and F. Z. Peng, "A hybrid modulation method for single-phase quasi-Z source inverter," in *Proc. IEEE Energy Convers. Congr. Expo. (ECCE)*, Sep. 2014, pp. 4444–4449.
- [54] M. Abbasi, A. H. Eslahchi, and M. Mardaneh, "Two symmetric extended-boost embedded switched-inductor quasi-Z-source inverter with reduced ripple continuous input current," *IEEE Trans. Ind. Electron.*, vol. 65, no. 6, pp. 5096–5104, Jun. 2018, doi: [10.1109/TIE.2017.2779433](https://doi.org/10.1109/TIE.2017.2779433).
- [55] E. S. Asl, E. Babaei, and M. Sabahi, "High voltage gain half-bridge quasi-switched boost inverter with reduced voltage stress on capacitors," *IET Power Electron.*, vol. 10, no. 9, pp. 1095–1108, Jul. 2017, doi: [10.1049/iet-pel.2016.0291](https://doi.org/10.1049/iet-pel.2016.0291).
- [56] Y. Liu, B. Ge, H. Abu-Rub, and F. Z. Peng, "An effective control method for quasi-Z-source cascade multilevel inverter-based grid-tie single-phase photovoltaic power system," *IEEE Trans. Ind. Informat.*, vol. 10, no. 1, pp. 399–407, Feb. 2014.

- [57] D. Sun, B. Ge, X. Yan, D. Bi, H. Zhang, Y. Liu, H. Abu-Rub, L. Ben-Brahim, and F. Z. Peng, "Modeling, impedance design, and efficiency analysis of quasi-Z source module in cascaded multilevel photovoltaic power system," *IEEE Trans. Ind. Electron.*, vol. 61, no. 11, pp. 6108–6117, Nov. 2014.
- [58] J. Khajesalehi, K. Sheshyekani, E. Afjei, and M. Hamzeh, "Maximum constant boost approach for controlling quasi-Z-source-based interlinking converters in hybrid AC–DC microgrids," *IET Gener. Transmiss. Distrib.*, vol. 10, no. 4, pp. 938–948, Mar. 2016, doi: [10.1049/iet-gtd.2015.0607](https://doi.org/10.1049/iet-gtd.2015.0607).
- [59] Y. Liu, B. Ge, H. Abu-Rub, and H. Sun, "Hybrid pulsewidth modulated single-phase quasi-Z-source grid-tie photovoltaic power system," *IEEE Trans. Ind. Informat.*, vol. 12, no. 2, pp. 621–632, Apr. 2016.
- [60] Q. Lei, F. Z. Peng, and B. Ge, "Pulse-width-amplitude-modulated voltage-fed quasi-Z-source direct matrix converter with maximum constant boost," in *Proc. 27th Annu. IEEE Appl. Power Electron. Conf. Expo. (APEC)*, Feb. 2012, pp. 641–646.
- [61] A. Abdelhakim, P. Davari, F. Blaabjerg, and P. Mattavelli, "Switching loss reduction in the three-phase quasi-Z-source inverters utilizing modified space vector modulation strategies," *IEEE Trans. Power Electron.*, vol. 33, no. 5, pp. 4045–4060, May 2018, doi: [10.1109/TPEL.2017.2721402](https://doi.org/10.1109/TPEL.2017.2721402).
- [62] V. Hari and G. Narayanan, "Space-vector-based hybrid PWM technique to reduce peak-to-peak torque ripple in induction motor drives," *IEEE Trans. Ind. Appl.*, vol. 52, no. 2, pp. 1489–1499, Mar. 2016, doi: [10.1109/TIA.2015.2487442](https://doi.org/10.1109/TIA.2015.2487442).
- [63] Y. Liu, H. Abu-Rub, and B. Ge, "Z-source/quasi-Z-source inverters: Derived networks, modulations, controls, and emerging applications to photovoltaic conversion," *IEEE Ind. Electron. Mag.*, vol. 8, no. 4, pp. 32–44, Dec. 2014.
- [64] Y. Liu, H. Abu-Rub, B. Ge, and F. Z. Peng, "Phase-shifted pulse-width-amplitude modulation for quasi-Z-source cascade multilevel inverter-based photovoltaic power system," *IET Power Electron.*, vol. 7, no. 6, pp. 1444–1456, Jun. 2014.
- [65] H. Rostami and D. A. Khaburi, "Voltage gain comparison of different control methods of the Z-source inverter," in *Proc. Int. Conf. Electr. Electron. Eng. (ELECO)*, Nov. 2009, pp. 1-268–I-272.
- [66] T.-D. Duong, M.-K. Nguyen, Y.-C. Lim, J.-H. Choi, and D. M. Vilathgamuwa, "SiC-based active quasi-Z-source inverter with improved PWM control strategy," *IET Power Electron.*, vol. 12, no. 14, pp. 3810–3821, Nov. 2019.
- [67] Y. Zhang, D. Xu, C. Yan, and S. Zou, "Hybrid PWM scheme for the grid inverter," *IEEE J. Emerg. Sel. Topics Power Electron.*, vol. 3, no. 4, pp. 1151–1159, Dec. 2015, doi: [10.1109/JESTPE.2015.2451159](https://doi.org/10.1109/JESTPE.2015.2451159).
- [68] S.-J. Chee, S. Ko, H.-S. Kim, and S.-K. Sul, "Common-mode voltage reduction of three-level four-leg PWM converter," *IEEE Trans. Ind. Appl.*, vol. 51, no. 5, pp. 4006–4016, Sep. 2015, doi: [10.1109/TIA.2015.2422771](https://doi.org/10.1109/TIA.2015.2422771).
- [69] L. Gu and K. Jin, "A three-phase isolated bidirectional AC/DC converter and its modified SVPWM algorithm," *IEEE Trans. Power Electron.*, vol. 30, no. 10, pp. 5458–5468, Oct. 2015, doi: [10.1109/TPEL.2014.2378274](https://doi.org/10.1109/TPEL.2014.2378274).
- [70] O. Husev, S. Stepenko, C. Roncero-Clemente, E. Romero-Cadaval, and D. Vinnikov, "Single phase three-level quasi-z-source inverter with a new boost modulation technique," in *Proc. 38th Annu. Conf. IEEE Ind. Electron. Soc. (IECON)*, Oct. 2012, pp. 5852–5857.
- [71] Y. Zhou, Q. Wu, Z. Li, and F. Hong, "Research on a time-variant shoot-through modulation strategy for quasi-Z-source inverter," *IEEE Trans. Power Electron.*, vol. 33, no. 11, pp. 9104–9109, Nov. 2018, doi: [10.1109/TPEL.2018.2815033](https://doi.org/10.1109/TPEL.2018.2815033).
- [72] S. Xiao, X. Gu, Z. Wang, T. Shi, and C. Xia, "A novel variable DC-link voltage control method for PMSM driven by a quasi-Z-source inverter," *IEEE Trans. Power Electron.*, vol. 35, no. 4, pp. 3878–3890, Apr. 2020, doi: [10.1109/TPEL.2019.2936267](https://doi.org/10.1109/TPEL.2019.2936267).
- [73] Y. Liu, B. Ge, H. Abu-Rub, and F. Z. Peng, "Overview of space vector modulations for three-phase Z-source/quasi-Z-source inverters," *IEEE Trans. Power Electron.*, vol. 29, no. 4, pp. 2098–2108, Apr. 2014.
- [74] Y.-X. Dai, H. Wang, and G.-Q. Zeng, "Double closed-loop PI control of three-phase inverters by binary-coded extremal optimization," *IEEE Access*, vol. 4, pp. 7621–7632, 2016, doi: [10.1109/ACCESS.2016.2619691](https://doi.org/10.1109/ACCESS.2016.2619691).
- [75] N. K. Godavarthi, P. S. R. Lakshmi, and V. T. S. Devi, "Comparative analysis of PWM methods of quasi Z source inverter," in *Proc. Int. Conf. Renew. Energy Sustain. Energy (ICRESE)*, Dec. 2013, pp. 86–90.
- [76] A.-V. Ho, T.-W. Chun, and H.-G. Kim, "Extended boost active-switched-capacitor/switched-inductor quasi-Z-source inverters," *IEEE Trans. Power Electron.*, vol. 30, no. 10, pp. 5681–5690, Oct. 2015.
- [77] X. Zhu, B. Zhang, and D. Qiu, "A high boost active switched quasi-Z-source inverter with low input current ripple," *IEEE Trans. Ind. Informat.*, vol. 15, no. 9, pp. 5341–5354, Sep. 2019, doi: [10.1109/TII.2019.2899937](https://doi.org/10.1109/TII.2019.2899937).
- [78] T. Na, Q. Zhang, J. Tang, and J. Wang, "Active power filter for single-phase quasi-Z-source integrated on-board charger," *CPSS Trans. Power Electron. Appl.*, vol. 3, no. 3, pp. 197–201, Sep. 2018, doi: [10.24295/CPSSSTPEA.2018.00019](https://doi.org/10.24295/CPSSSTPEA.2018.00019).
- [79] H. Abu-Rub, A. Iqbal, S. Moin Ahmed, F. Z. Peng, Y. Li, and G. Baoming, "Quasi-Z-source inverter-based photovoltaic generation system with maximum power tracking control using ANFIS," *IEEE Trans. Sustain. Energy*, vol. 4, no. 1, pp. 11–20, Jan. 2013.
- [80] M. Mosa, H. Abu-Rub, and J. Rodríguez, "High performance predictive control applied to three phase grid connected Quasi-Z-Source inverter," in *Proc. 39th Annu. Conf. IEEE Ind. Electron. Soc. (IECON)*, Nov. 2013, pp. 5812–5817.
- [81] J. Liu, S. Jiang, D. Cao, and F. Z. Peng, "A digital current control of quasi-Z-source inverter with battery," *IEEE Trans. Ind. Informat.*, vol. 9, no. 2, pp. 928–937, May 2013.
- [82] G.-R. Zhu, H. Wang, B. Liang, S.-C. Tan, and J. Jiang, "Enhanced single-phase full-bridge inverter with minimal low-frequency current ripple," *IEEE Trans. Ind. Electron.*, vol. 63, no. 2, pp. 937–943, Feb. 2016.
- [83] Y. Liu, B. Ge, H. Abu-Rub, and D. Sun, "Comprehensive modeling of single-phase quasi-Z-source photovoltaic inverter to investigate low-frequency voltage and current ripple," *IEEE Trans. Ind. Electron.*, vol. 62, no. 7, pp. 4194–4202, Jul. 2015.
- [84] W. Liang, Y. Liu, B. Ge, H. Abu-Rub, R. S. Balog, and Y. Xue, "Double-line-frequency ripple model, analysis, and impedance design for energy-stored single-phase quasi-Z-source photovoltaic system," *IEEE Trans. Ind. Electron.*, vol. 65, no. 4, pp. 3198–3209, Apr. 2018.
- [85] B. Ge, "An active filter method to eliminate DC-side low-frequency power for a single-phase quasi-Z-source inverter," *IEEE Trans. Ind. Electron.*, vol. 63, no. 8, pp. 4838–4848, Aug. 2016.
- [86] B. Ge, Y. Liu, H. Abu-Rub, R. S. Balog, F. Z. Peng, S. McConnell, and X. Li, "Current ripple damping control to minimize impedance network for single-phase quasi-Z source inverter system," *IEEE Trans. Ind. Informat.*, vol. 12, no. 3, pp. 1043–1054, Jun. 2016.
- [87] Y. Zhou, H. Li, and H. Li, "A single-phase PV quasi-Z-source inverter with reduced capacitance using modified modulation and double-frequency ripple suppression control," *IEEE Trans. Power Electron.*, vol. 31, no. 3, pp. 2166–2173, Mar. 2016.
- [88] R. Y. Wei, Y. F. Tang, S. J. Wang, and Z. Y. Li, "A ripple suppression strategy based on virtual self-injection APF for quasi-Z source inverter," *IOP Conf. Earth Environ. Sci.*, vol. 188, Oct. 2018, Art. no. 012065.
- [89] M.-K. Nguyen and Y.-O. Choi, "Maximum boost control method for single-phase quasi-switched-boost and quasi-Z-source inverters," *Energies*, vol. 10, no. 4, p. 553, Apr. 2017.
- [90] Y. Yu, Q. Zhang, B. Liang, and S. Cui, "Single-phase Z-source inverter: Analysis and low-frequency harmonics elimination pulse width modulation," in *Proc. IEEE Energy Convers. Congr. Expo.*, Sep. 2011, pp. 2260–2267.
- [91] M. Mohammadi, J. S. Moghani, and J. Milimonfared, "A novel dual switching frequency modulation for Z-source and quasi-Z-source inverters," *IEEE Trans. Ind. Electron.*, vol. 65, no. 6, pp. 5167–5176, Jun. 2018.
- [92] Y. He, Y. Xu, and J. Chen, "New space vector modulation strategies to reduce inductor current ripple of Z-source inverter," *IEEE Trans. Power Electron.*, vol. 33, no. 3, pp. 2643–2654, Mar. 2018.
- [93] Y. Tang, S. Xie, and J. Ding, "Pulsewidth modulation of Z-source inverters with minimum inductor current ripple," *IEEE Trans. Ind. Electron.*, vol. 61, no. 1, pp. 98–106, Jan. 2014.
- [94] S. Bayhan, M. Trabelsi, H. Abu-Rub, and M. Malinowski, "Finite-control-set model-predictive control for a quasi-Z-source four-leg inverter under unbalanced load condition," *IEEE Trans. Ind. Electron.*, vol. 64, no. 4, pp. 2560–2569, Apr. 2017.
- [95] H. Komurcugil, S. Bayhan, F. Bagheri, O. Kukrer, and H. Abu-Rub, "Model-based current control for single-phase grid-tied quasi-Z-source inverters with virtual time constant," *IEEE Trans. Ind. Electron.*, vol. 65, no. 10, pp. 8277–8286, Oct. 2018.
- [96] Y. Li, W. Gao, J. Li, R. Zhang, and F. Fang, "Double line frequency ripple cancelling for single-phase quasi-Z-source inverter," in *Proc. IEEE Energy Convers. Congr. Expo. (ECCE)*, Sep. 2016, pp. 1–6.
- [97] J. Lamb and B. Mirafzal, "An adaptive SVPWM technique for cascaded multilevel converters with time-variant DC sources," *IEEE Trans. Ind. Appl.*, vol. 52, no. 5, pp. 4146–4155, Sep. 2016, doi: [10.1109/TIA.2016.2573755](https://doi.org/10.1109/TIA.2016.2573755).

- [98] X. Li, P. Lin, Y. Tang, and K. Wang, "Stability design of single-loop voltage control with enhanced dynamic for voltage-source converters with a low LC-resonant-frequency," *IEEE Trans. Power Electron.*, vol. 33, no. 11, pp. 9937–9951, Nov. 2018, doi: [10.1109/TPEL.2018.2794066](https://doi.org/10.1109/TPEL.2018.2794066).
- [99] D. Pan, X. Ruan, X. Wang, F. Blaabjerg, X. Wang, and Q. Zhou, "A highly robust single-loop current control scheme for grid-connected inverter with an improved LCCL filter configuration," *IEEE Trans. Power Electron.*, vol. 33, no. 10, pp. 8474–8487, Oct. 2018, doi: [10.1109/TPEL.2017.2783301](https://doi.org/10.1109/TPEL.2017.2783301).
- [100] M.-K. Nguyen and Y.-O. Choi, "PWM control scheme for Quasi-Switched-Boost inverter to improve modulation index," *IEEE Trans. Power Electron.*, vol. 33, no. 5, pp. 4037–4044, May 2018, doi: [10.1109/TPEL.2017.2717487](https://doi.org/10.1109/TPEL.2017.2717487).



SEYFETTIN VADI received the master's degree from the Gazi University Institute of Science, in 2013, where he is currently pursuing the Ph.D. degree. He is also working as a Lecturer with the Department of Electronics and Automation, Vocational School of Technical Science, Gazi University, Ankara. He has participated in scientific meeting in Istanbul on the implementation of a PLC and OPC-based SC Motor Control Laboratory. His has published articles are scanned by SCI, SCI-EXP, SSCI, AHCI, and other noteworthy indices. His areas of interest include automation systems, SCADA systems, micro networks, energy monitoring and control systems, reactive power compensation, software development, databases, microcontrollers, and robotic systems.



RAMAZAN BAYINDIR (Senior Member, IEEE) received the bachelor's degree from the Electrical Education Department, Gazi University, in 1992, and the M.Sc. and Ph.D. degrees from the Institute of Science and Technology, Gazi University, in 1998 and in 2002, respectively. He worked as a Research Assistant and an Assistance Professor with the Electrical Education Department, Gazi University. He became an Associate Professor at the Electrical and Electronics Engineering Department, Gazi University, where he is currently working as a Professor. He has published journal and conference papers on renewable energy sources, microgrids, distributed generation, smart grid applications, and industrial automation. His main expertise fields include renewable energy sources, microgrids, distributed generation, smart grid applications, and industrial automation with programmable logic controller (PLC). He has

been the Program Chair to the annual conference of the International Conference on Renewable Energy Research and Applications (ICRERA 2012-2017), 16th International Power Electronics and Motion Control Conference and Exposition (PEMC 2014), and International Conference on Power Engineering, Energy and Electrical Drives (POWERENG 2013) conference. He has served as a Guest Editor for some SCI-indexed reputable journals. He also is an Editor of the *Journal of Science and Technology: PART C*. He has also served as a Reviewer to many high-ranked scientific journals. Some international (EU) projects are 2007 and 2013 Transfer of Innovation and Partnership Project Programs. He has some key qualifications, such as education and curriculum design and development on different fields, vocational and technical education, designing, organization and planning the international level projects, educational and vocational training material development.



EKLAS HOSSAIN (Senior Member, IEEE) received the B.S. degree in electrical and electronic engineering from the Khulna University of Engineering and Technology, Bangladesh, in 2006, the M.S. degree in mechatronics and robotics engineering from the International Islamic University of Malaysia, Malaysia, in 2010, and the Ph.D. degree from the College of Engineering and Applied Science, University of Wisconsin Milwaukee (UWM).

He has been involved with several research projects on renewable energy and grid tied microgrid system at Oregon Tech, as an Assistant Professor with the Department of Electrical Engineering and Renewable Energy, since 2015. He is currently working as an Associate Researcher with the Oregon Renewable Energy Center (OREC). He is also a registered Professional Engineer (PE) of Oregon, USA. He is also the Certified Energy Manager (CEM) and a Renewable Energy Professional (REP). He has also been working in the area of distributed power systems and renewable energy integration, for last ten years. He has published a number of research articles and posters in this field. His research interests include modeling, analysis, design, and control of power electronic devices, energy storage systems, renewable energy sources, integration of distributed generation systems, microgrid and smart grid applications, robotics, and advanced control systems. He is a Senior Member of the Association of Energy Engineers (AEE). He is also the winner of the Rising Faculty Scholar Award, in 2019, from the Oregon Institute of Technology for his outstanding contribution in teaching. He is also serving as an Associate Editor for IEEE Access. He, with his dedicated research team, is looking forward to explore methods to make the electric power systems more sustainable, cost-effective, and secure through extensive research and analysis on energy storage, microgrid systems, and renewable energy sources.

...