

A Review of Crane Safety in the Construction Industry

Richard L. Neitzel, Noah S. Seixas, and Kyle K. Ren

University of Washington, Department of Environmental Health, Seattle, Washington

The complex, dynamic, and continually changing nature of construction work has been recognized as an important contributor to the high rates of injuries and fatalities in the industry. Cranes are a central component of many construction operations and are associated with a large fraction of construction deaths; in fact, estimates suggest that cranes are involved in up to one-third of all construction and maintenance fatalities. Safety and health professionals serving the construction industry need adequate training and knowledge regarding available crane safety devices and procedures so that they may insure these techniques are effectively utilized during construction operations. This paper reviews available information on crane-related injuries, currently available safety devices, and commonly used crane safety procedures. Recommendations for improved crane injury prevention and future crane safety research are given.

Keywords Crane Safety, Crane-Related Injuries and Deaths, Mobile Cranes, Tower Cranes, Construction Industry, Safety Procedures and Mechanisms

The construction industry involves complex and dynamic work environments that present new hazards to workers on a daily, or even hourly, basis. As a result of the complicated and constantly changing nature of construction work, the construction industry has very high injury and fatality rates compared to other U.S. industries.⁽¹⁾ While there are a number of causal factors behind these high accident rates, many construction injuries and fatalities can be attributed to one ubiquitous piece of equipment: the crane. Cranes, which come in numerous configurations and are a critical component of most construction work, contribute to as many as one-third of all construction and maintenance fatalities and injuries resulting in permanent disability.⁽²⁾

Construction work differs from other industries in that workers are continuously confronted with new challenges and dangers as their work progresses. In a typical industrial setting, workers

are exposed to the same environment and hazards every day. In contrast, a construction worker may work for more than five different employers in one year at a dozen or more different sites. As every construction site progresses, new hazards and risks develop. An individual site may feature a number of very different environments; for example, new construction activities may occur adjacent to demolition activities. Cranes add yet another dimension to this complex environment, carrying loads over, into, and around the workers' environment.

In this article, we review crane-related injury data, methods for reducing the severity and number of crane accidents, and opportunities for future crane safety research and activities.

CRANE DESIGN AND USE

An incredible variety of cranes have been designed since the introduction of high-strength steels in the 1950s.⁽³⁾ The proliferation of cranes in construction is impressive, with approximately 125,000 cranes operating among all sectors of the United States construction industry.⁽⁴⁾ Large construction projects can feature as many as 150 cranes, as demonstrated at the Boston Central Artery/Tunnel.⁽⁵⁾ There are two basic construction crane designs, mobile and tower, each of which can be found in literally hundreds of different configurations. For example, mobile cranes can have telescoping or lattice booms and may ride on rubber tires or tracks. Lattice (cage-type) mobile crane booms can be moved in nearly any direction and may be lengthened or shortened by adding or removing boom sections; extensions, called jibs, are often added to lattice booms resulting in total boom/jib lengths exceeding 500 ft.⁽³⁾ Boom angles on lattice boom cranes are controlled by cables wound onto motor-driven drums. Telescoping booms consist of several nested closed-tube sections that are extended or retracted by a hydraulic cylinder; boom angles are controlled using one or more hydraulic cylinders located between the boom base and the crane turntable.⁽⁶⁾ Mobile boom cranes range in size from small, highly mobile cherry pickers, with lift capacities of 15 to 80 tons, to larger models with lift capacities of up to 1,000 tons and total boom lengths up to 600 ft.⁽⁷⁾ Mobile cranes may also be fitted with a

tower attachment. Figure 1 illustrates several common styles of tower and mobile cranes.

Tower cranes can be located internal or external to a building, may or may not feature a climbing section in their support structure that allows elevation gain as the building under construction increases in height, and may have a fixed horizontal (“hammerhead”) boom with a trolley-mounted hoist, or a moveable, variably angled-above-horizontal (“luffing”) boom with a rigged tip.⁽³⁾ As with mobile cranes, lift capacity and size of tower cranes varies substantially (according to load weight and hoist distance from center of gravity), with tower heights over 200 ft, boom lengths ranging from 50 to more than 250 ft, and load capacities from 0.5 to more than 22 tons.

Given the size and power of available cranes, the potential for loss of property and life at sites or operations utilizing cranes without proper planning and safety procedures is tremendous. A typical large urban commercial construction site might feature two tower cranes and a mobile crane, all working simultaneously to move materials around a highly congested, vertically oriented site. These cranes are normally operated by an operating engineer working with a rigger (who rigs and guides loads) and possibly a signalman (who guides loads). Truck-mounted cranes will visit the site frequently to deliver materials; these cranes are usually operated by the truck’s driver, who may not be adequately trained on proper crane operation. Crane operators lift and carry unfamiliar and often unstable loads over and

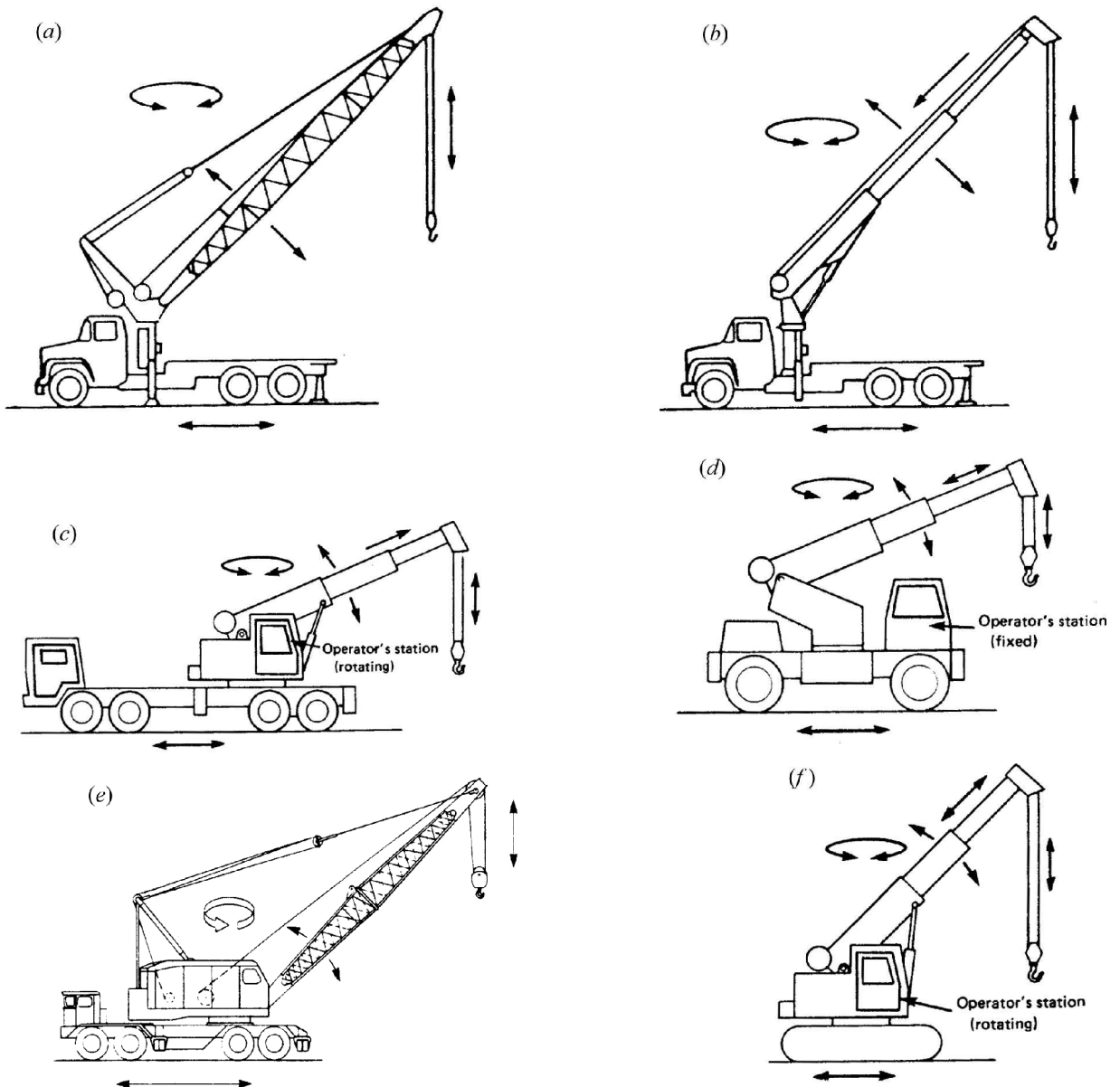

FIGURE 1a-f.
(Continued on next page)

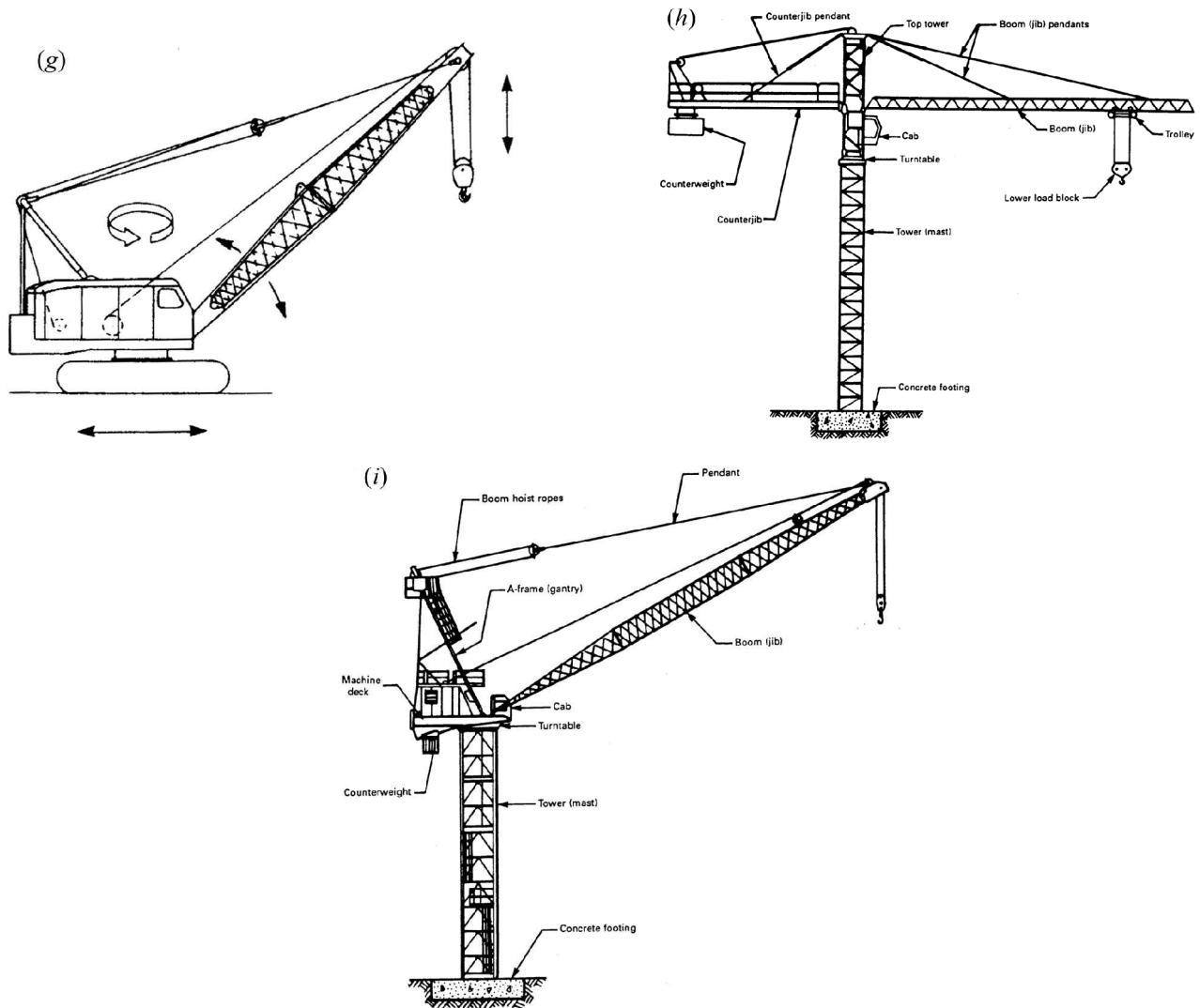

FIGURE 1g-i (Continued).

Tower and mobile crane examples. Reprinted from ASME B30.3-1996 and B30.5-1994, by permission of the American Society of Mechanical Engineers. All rights reserved.

around large numbers of construction workers, often depositing loads in very close proximity to incognizant workers involved in activities totally unrelated to the crane, and sometimes under circumstances where the load is not within sight of the operator. A tipped, dropped, or mishandled load can directly injure workers or even potentially upset a critical section of the construction project, possibly resulting in the collapse of the structure. This risk of loss is not limited only to those directly involved in construction operations, as evidenced by several recent crane accidents,⁽⁸⁾ in which pedestrians were killed.

Construction cranes differ from industrial cranes in that each lift typically involves a load with unique properties and characteristics. As a result, every lift has the potential to modify the crane's maneuverability, stability, and load capacity. These alterations in performance require operators to be keenly aware of a crane's handling properties and limitations. Surprisingly,

there is currently no universally accepted certification or licensing of crane operators, who are often the most highly trained and highly paid nonmanagement personnel on construction sites.⁽⁶⁾ There are an estimated 45,000 full-time mobile and tower crane operators in the United States, based on current census data⁽⁹⁾ (this number includes, but is not limited to, the construction industry).

CRANE INJURY STATISTICS

The confusion created by a transient workforce employed on multiple complex and constantly evolving construction sites near heavy equipment and cranes certainly contributes to the high number of construction injuries and fatalities. Cranes are complex machines that many individuals are peripherally aware of but few have experience operating or rigging.

Despite high rates of fatalities and injuries, Veazie et al.⁽¹⁰⁾ found a paucity of epidemiological research in the construction industry. Even fewer studies have focused specifically on the etiology of crane-related incidents, which account for the greatest number of fatalities among all causes within the construction industry.⁽¹¹⁾ For example, a 1987 U.S. Bureau of Labor Statistics data set containing injury information reported by 23 states showed over 1,000 construction injuries involving cranes and hoisting equipment,⁽⁸⁾ but had no specific information about the activities or actions leading to these injuries. A British study found that cranes are involved in 17% of all construction fatalities in that nation,⁽¹²⁾ but again did not identify causal factors or environments.

Although the majority (87%) of crane-related deaths occur among workers other than crane operators, the number of operator fatalities—while low when considered in terms of absolute numbers—is tremendous when the relatively small population of operators is considered. A recent report on crane and hoist safety in the United States calculated a death rate of 1.4 deaths per 1,000 operators over a 45-year working lifetime.⁽⁸⁾ Although this mortality rate indicates that crane operators are clearly at risk, the fact that operators comprised only 13% of all victims in crane-related construction deaths in an Occupational Safety and Health Administration (OSHA) investigation of 502 crane-related deaths⁽¹³⁾ indicates that crane safety research must focus on risk factors for both crane operators and those working near the crane. Overall, cranes were associated with 306 construction fatalities (16.1% of all construction fatalities) between 1980–1992; that corresponds to an incidence rate of 0.34 deaths per 100,000 workers.⁽¹¹⁾ This figure is much smaller than that provided by MacCollum, who suggests that as many as 33% of construction casualties are related to cranes.⁽²⁾ However, MacCollum includes both fatalities and permanent disabilities in his estimate. Rates for non-operators cannot be calculated because there are no exposure data available to even estimate the number of workers at risk (it is extremely difficult to precisely define what factors are needed to constitute worker exposure to a crane). This lack of exposure data is an ongoing problem in statistically assessing the true extent of the hazards presented by cranes and the risk associated with working near cranes.

The 1996 OSHA study of 502 crane-related fatalities identified the leading causes of death as electrocution (39%), crane assembly/dismantling (12%), boom buckling/collapse (8%), crane upset/overturn (7%), rigging failure (7%), overloading (4%), and struck by moving load (4%).⁽¹³⁾ Other causes of fatalities included two-blocking, killer hooks, and hoist limitations (See Appendix A failure descriptions). These findings agree with other studies, which have also reported electrocutions as the leading cause of fatality.^(2,14) A 1995 NIOSH alert also cited OSHA statistics indicating that 65% of work-related electrocutions (377 deaths) occurred in the construction industry, and that, of those, 30% (113 deaths) involved cranes.⁽¹⁵⁾ A 1996 review of OSHA reports found that 108 of 284 (38%) heavy-equipment-related construction electrocutions were caused

by cranes.⁽¹⁴⁾ Each year between 1980 and 1989 an average of 15 electrocutions were identified by OSHA as being caused by crane contact with energized powerlines; more than half of these crane-related deaths occurred in construction.⁽¹⁶⁾ A New Jersey study found 5 of 27 construction electrocutions involved transmission of current through some part of a crane.⁽¹⁷⁾ Clearly, operating cranes near live power lines is a potentially deadly activity, and improved mechanisms of avoiding this potential hazard are needed.

Different types of cranes are associated with different kinds of accidents, and also varying severity. For example, the 1997 Suruda study⁽¹³⁾ found that 93% of all crane deaths associated with assembly or dismantling of cranes involved lattice-boom cranes (deaths typically occurred when booms supported only by the hoist line fell, crushing workers below), while only 7% of assembly/dismantling deaths were associated with tower cranes. Other common causes of death during assembly/dismantling of all types of cranes include insufficient working facilities, unsafe ropes and anchorages, and weather conditions.⁽¹⁸⁾ The National Safety Council (NSC) has attributed 90% of mobile crane accidents to “operator error,”⁽⁷⁾ though no definition of operator error is provided. Other factors associated with mobile crane accidents include support failure (30%), failure to use outriggers (20%), crane failure (10–20%), and rigging failure (4–15%).⁽⁷⁾

MODES OF CRANE FAILURE

Cranes can fail, sometimes catastrophically, in a number of different ways. One generally accepted list of 13 failure modes in cranes was put forth by David MacCollum in 1980⁽¹⁹⁾ (Appendix A). These modes are: overloading, side pull, outrigger failure, hoist limitations, two-blocking, killer hooks, boom buckling, upset/overturn, unintentional turntable turning, oversteer/crabbing, control confusion, access/egress, and unintentional power line contact. Other modes which have been identified include improper assembly/dismantling, rigging failure/fall of load or lifting tackle, being struck by a moving load, and being struck by the crane itself.⁽¹³⁾

CRANE SAFETY STANDARDS

The U.S. Occupational Safety and Health Administration has promulgated construction crane safety standards in volume 29 of the Code of Federal Regulations, Section 1926. Some U.S. states have separate crane safety standards that are at least as effective as OSHA's regulations. In general, these regulations reference American National Standards Institute (ANSI)/American Society of Mechanical Engineers (ASME) standards B-30.1 through B-30.6. These voluntary standards were updated in the late 1980s and early 1990s; however, the regulatory standards generally reference the versions published in the late 1960s. Two ANSI/ASME standards delineate safe operation and maintenance practices for construction cranes: B-30.3-Construction Tower Cranes, and B-30.5-Mobile and Locomotive Cranes. The multitude of diverse and technically complicated crane designs, combined

with the complexity of current regulatory and voluntary crane safety standards, means that construction employers and regulatory enforcement agencies need to employ one or more qualified full-time crane safety specialists to insure adequate knowledge of the complexities of crane design and operation.

CRANE SAFETY EQUIPMENT

A number of safety devices have been developed which, if properly utilized, could reduce the number of crane-related injuries and fatalities; however, the extent of their utilization is not known. These safety devices can be grouped into five broad categories: anti-current, anti-upset, operator and rigger protection, anti-collision, and other.

Anti-Current Devices

Anti-current devices prevent the transmission of electrical current from energized power lines to crane components in contact with the lines, or to personnel in contact with the crane. These devices include insulated boom cages, insulated lines or links, and insulated barriers. Proximity or current warning devices are also included in this category; these do not interrupt the transmission of electricity, but rather prevent crane contact with energized structures completely.

An insulated boom cage is a skeletal framework of electrically nonconductive material mounted on the rigged tip of a boom to prevent the conductive metal boom framework from contacting an energized power line and creating a ground fault circuit.⁽²⁰⁾ The skeletal nature of these devices cannot ensure that no power line contact will occur, and instead only lessens the chances of such an event. Also, if the cage is installed improperly, a ground fault is still possible.

Insulated lines or links are inserted between a crane's hook and the lifted load, preventing a current from flowing down the hoist line, and therefore protect individuals guiding the hoisted load. The load itself will not become energized, but the hoist line (above the link) and crane will, since they are not protected from the current and are in the ground fault circuit. Testing has shown these links to be highly effective, even when contaminated with mud and other substances,⁽²⁾ although contamination does cause some breakdown in their insulating properties.⁽²¹⁾

Insulating barriers (which are not attached to equipment or machines) may also be used when work is performed near energized power lines. These barriers are designed to prevent physical contact with lines and may be made of hard rubber where brush (rather than direct) contact is likely. Where the possibility of direct contact is more than minimal, ASTM recommends plastic barriers. Barriers are a poor substitute for de-energizing lines, as crane performance characteristics are such that they are almost always able to overwhelm a barrier.

Proximity warning/current detector devices detect the presence of an electrical field and give a warning signal to the operator. The devices, which cost approximately \$2000, are low frequency radio receivers that detect 60 Hz radiation.⁽²¹⁾ Crane operators may benefit from this alarm, but may also eventually

use the warning to determine the distance between the boom and power line, and fail to allow a safety margin for overrun or sway of the crane's boom.⁽²²⁾ In addition, there is some evidence that the devices are highly sensitive to orientation and are ineffective in the presence of multiple power lines.⁽²¹⁾ However, proximity alarms can be very effective in mobile crane pick-and-carry operations, where the operator may be briefly unaware of the presence of power lines in the boom path during travel due to the necessary focus on the load, not the boom tip.⁽²³⁾ Proximity warnings need not be complex electronic devices; one simple warning in cases where long-term crane activity is expected is a flagged line strung adjacent to power lines to provide a visual indicator of the line. While these devices provide a secondary means of preventing cranes from becoming energized, and should be used whenever feasible, they must not be used as a primary method for avoiding power lines.

Because none of these protective devices is fail-safe, none of them may be used as a replacement for de-energizing or removing power lines in areas in which construction cranes are operating. As standard practice, all power lines should be considered energized until the owner of the line or the electric company confirms the status of the line as de-energized. The utility and reliability of anti-current devices has been questioned,⁽¹³⁾ and all anti-current devices should be considered redundant safety measures, secondary to a visual inspection for power lines.

Anti-Upset Devices

Anti-upset devices prevent a crane from overturning or tipping, and therefore protect against the resulting support or chassis hardware failure. Anti-upset devices are critical, as the difference between the rated capacity of a crane and its actual tipping load (the margin of safety) is typically between 15% and 25%, depending on the type of crane.⁽²³⁾ The rate of crane upsets is about one per every 10,000 hours of operation (or once per 5 years of full-time use); about 75% of upsets are the result of circumstances related to operator error (i.e. fail to use outriggers). Approximately 3% of upsets result in fatalities, and about 8% result in lost-time injuries.⁽²³⁾ Anti-upset devices include levels and boom angle indicators, load charts/monitors and load moment indicators, all of which feed information to the operator to assist in allow safe operation, and outriggers, boom stops, anti-two-block mechanisms, wind sensors, and brakes, which insure crane stability.

Crane cabs should be equipped with spirit levels to insure that operators can gauge the levelness of the crane in all four directions.⁽²³⁾ Levels also reduce the likelihood of side pull forces on the boom. Boom angle indicators are required on all mobile cranes, but should not be relied on for accuracy, since they read the angle at the base of the boom and therefore do not account for outer section deflection, which may give up to a 2 degree reading error.⁽²⁴⁾

Electronic monitors are available that, when attached to load sensors such as load pins, tension links, dynamometers, hydraulic pressure sensors, or instrumented sheaves,⁽²⁵⁾ display

the weight of a lifted load in absolute terms and as a percentage of the crane's rated lift capacity. These monitors may feature alarms that sound under some conditions, including when an overload or slack line is detected, and may even actively prevent a lift from exceeding allowable parameters. ANSI recommends load monitors on all new cranes with capacities over 3 tons.

Every mobile crane must have a capacity plate located within clear view of the operator's controls that shows safe load capacities for all possible boom angles and radii from the turntable. A gravity-operated boom angle indicator that visually depicts the current angle of the boom should also be present.⁽⁷⁾ The capacity plate chart requires the operator to combine boom angle with load radius (boom length) and outrigger information to yield a safe load capacity. This information may be incorporated into a load moment indicator (LMI), which combines information on load and boom angle electronically (reducing the mental burden on the operator) and provides the crane operator with a warning signal if the load moment required to upset the crane is approached or exceeded.⁽²⁶⁾ Cranes are more prone to upset in certain situations, due to factors such as degree of rotation over the side of the chassis, length of the boom and boom angle, weight of the lifted load, and effective use of outriggers. An LMI can provide a real-time indication of the status of many of these variables. Newer LMIs can prevent a crane from exceeding its performance envelope; these LMIs are called Load Moment Limiters.⁽²³⁾ Outriggers are considered part of the counterweight on the load charts of new mobile rubber-tired cranes, and separate load charts are provided for traveling lifts without the use of outriggers.⁽⁷⁾ Outriggers are only effective when used on solid ground, so heavy reinforcing materials such as timber should be used when ground stability is at all in doubt. Mobile crawler cranes spread their weight over a larger area of ground and do not require outriggers, but may have extendable crawlers to increase ground surface area. Interlocks designed to prevent loads from swinging over the side of the crane without outrigger deployment are available and should be installed on mobile rubber-tired cranes not accompanied by specifications for allowable lifts made on rubber.

Boom stops are used to prevent the boom from being raised to an angle that might allow the lifted load to contact the underside of the boom. If load-boom contact occurs, the boom's structural integrity may be compromised, and a subsequent lift may end in a dropped load or failed boom. Electrical interlock boom stop systems are available that actively prevent boom movement above 86°. An alternative boom stop system involves the use of energy-absorbing, spring-loaded or hydraulic "shocks," which stabilize boom movement.^(23,27) Boom stops are necessary on lattice-boom cranes, which can go "over the top" and fall over the backside of the crane chassis if lifted too high.^(6,27) Positive boom stops should be present on all mobile cranes.

Due to their height, tower cranes are often subjected to stronger winds than are encountered at ground level—the wind velocity differential may exceed 100 mph.⁽³⁾ When not in use, rotation brakes should set in low winds; however, when winds

reach a certain critical level (which varies by model), the crane should be allowed to weathervane, which reduces the amount of torque applied to the tower.^(2,27) Wind sensors allow real-time monitoring of conditions; however, weather forecasts must be considered for periods when the crane will be unmanned. Tower cranes should have slewing (rotating) brakes capable of preventing boom rotation and of stopping a loaded boom; furthermore, these brakes should require no further attention from the crane's operator once applied. Tower crane trolley brakes should also be capable of stopping and holding a moving, loaded trolley (again, with no further attention needed once applied). All tower crane brakes should set automatically in the event of power failure, and maximum wind velocities in which tower cranes may be erected or raised must be specified, with erection prohibited in winds exceeding those velocities without manufacturer approval.

Anti-two-blocking devices are limit switches which prevent the lower load block, or hook assembly, from coming into contact with the upper load block, or boom point sheave assembly. These devices are not traditionally considered anti-upset mechanisms; however, by preventing boom damage or failure, they do, in effect, provide anti-upset protection. If the upper and lower blocks do come into contact, the hoist line can break, releasing the suspended load. ANSI recommends that the use of anti-two-blocking devices, or systems which stop hoisting action before two-blocking damage occurs, should be considered a damage-prevention measure only.

Operator and Rigger Protection Mechanisms

Operator and rigger protection mechanisms reduce the possibility of human factors related crane failures in which the crane's operator or nearby personnel are injured as a result of crane chassis, rigging, or electrical failures. Cab reinforcement is one approach to reducing the likelihood of the operator being injured or killed if an object strikes the crane's cab. It is not necessarily an appropriate strategy for tower cranes, where the operator is far above the ground and, generally, the load; however, for mobile cranes it can be crucial. Strengthening the control cab of a mobile crane (*vis-à-vis* the Rollover Protection Systems required on heavy equipment) can prevent the cab from being crushed or deformed in the event that it contacts a lifted load. All crane cabs should be equipped with distortion-free safety (impact-resistant) glass, and should also have windshield wipers for foul-weather visibility. While recommended by some regulatory agencies,⁽²⁸⁾ rigid bumpers attached to the crane's superstructure to keep the rigger out of the danger zone between the crane and its load are not an acceptable barricade substitute in the United States.

Anti-Collision Devices

Anti-collision devices are intended to eliminate the possibility of crane chassis and human factors failures resulting from the movement of cranes or other vehicles, such as aircraft. Fixed tower cranes operating in or near airfield flight paths are

commonly equipped with standard red flashing strobe lights akin to those found on tall permanent structures. These lights, when activated and properly maintained, reduce the risk of aircraft-crane collisions.

One device which serves both an anti-collision and anti-current function consists of a nonconductive line strung alongside power cables and fitted with high visibility flags.

The National Safety Council recommends that traveling tower cranes (erected on a rail-mounted undercarriage) be equipped with an audible warning device that sounds continuously during crane travel. A rotating or strobe light should also be used to alert nearby personnel of crane movement, particularly in noisy environments where audible warnings may not be heard.⁽⁷⁾ Tower cranes mounted on rail tracks should be equipped with limit switches that limit the travel of the crane on the track, and that track ends also should be equipped with stops or buffers.

At least one manufacturer offers an anti-collision device for tower cranes working in tandem. This device consists of a radar slaved to a motion-cut mechanism which will halt crane motion upon sensing potential interference from the other crane.⁽²⁵⁾

Other

Several devices are available that may reduce the possibility of rigging failures. For example, all hooks used in crane operations on construction sites should have safety latches. These latches secure load straps or chains within the throat of the hook and prevent them from slipping off the hook unexpectedly. Safety latches should be heavy enough to prevent them from being damaged easily, and they should be double-locking. Over 100 positive-action hook safety latches have been patented, and many are commercially available.⁽²³⁾ A properly designed and maintained hook safety latch will prevent a dropped load or crane upset from sudden boom movement by not allowing a moving load to escape the hook. Well-designed hooks feature a vertical pivot, which insures that the hook throat always faces horizontally and never vertically (which could place the entire load weight squarely on the safety latch and induce failure). Hooks with missing, damaged, or defective throat latches are sometimes called "killer hooks."⁽²³⁾

Climbing tower cranes should have overpressure relief valves, direct-read pressure gauges, and pilot-operated hydraulic check valves installed to prevent the climbing jack from retracting should a hydraulic line or fitting fail. Limit switches should be installed which prevent tower cranes from lifting loads greater than 110% of the maximum rated load, and tower cranes should be fitted with trolley buffers (analogous to limit switches) at both ends of travel.

Load drum rotation indicators transmit to the operator a tactile, audible, or visible signal indicating that the load cable or rope is in motion. This signal allows the operator to focus on the load itself, rather than having to watch the nearest portion of rope or cable for motion, and therefore protects the rigger and crane itself from contact with an unexpected moving load.⁽²⁵⁾

CRANE SAFETY PROCEDURES

Procedures have been developed which can further enhance the safety of crane operations. These procedures can be divided into five categories: training, certification, maintenance/inspection, communication, and electrical procedures. One of the most important and obvious crane safety procedures is that all lifts should be conducted so that, if an equipment failure were to occur, no personnel would be injured by a dropped load;⁽⁷⁾ therefore, all workers must be kept clear of loads about to be lifted or suspended loads.

Training

Training is intended to reduce or eliminate the possibility of human-factors-related crane failure and to involve personnel in the selection and use of safety devices. In the United States, the NSC specifies the following minimum qualifications for a crane operator: that they meet the legal age for crane operation in the area the crane will be operated; that they speak and understand written English; that they pass a physical examination, including visual depth perception; that they have adequate understanding of the crane they are operating; and that they can demonstrate satisfactory skill in operating the crane.⁽⁷⁾ David MacCollum, a recognized authority on crane safety, has suggested additional qualifications, including emotional stability, freedom from habitual drug usage, freedom from seizures or other loss of physical control, and that candidates provide a list of previous injuries or property damage resulting from their own equipment operation.⁽²³⁾ In addition to minimum qualifications, operators should also receive formal classroom training from qualified, competent instructors to insure sufficient crane knowledge, and should consider certification (see next page).

Electrocutions are a hazard not only to the crane operator but also to individuals in contact with the crane or load. MacCollum⁽²⁾ found that eight out of 10 electrocutions were to people guiding the load at the time of power line contact. Clearly, riggers and signalmen are at risk while working with crane loads. Riggers should always utilize taglines (lines used to guide a lifted load into place). In addition to providing load placement control, tag lines help ensure that a lifted load will not swing into the boom, which can cause boom failure.⁽²³⁾ Riggers should be trained to identify hazardous conditions in crane rigging, such as wire rope deformation, strain, binding, or kinking. OSHA and ANSI have published regulations for inspecting wire rope used for rigging, and specify minimal acceptable rope criteria including rope diameter and deformation. OSHA requires inspection of machinery and other equipment (including wire ropes) by a competent person before each use, and rigging equipment should be inspected prior to use on each shift and as necessary during its use to ensure that it is safe. Defective rigging equipment must be immediately removed from service. Riggers and signalmen are a critical part of crane operations, and they need to receive training similar to that provided to operators.

It is imperative (and required by OSHA and ANSI) that crane maintenance personnel be properly trained to work on

the specific pieces of equipment they are responsible for maintaining. In addition to insuring proper function and structural integrity of equipment, maintenance personnel must understand how individual components interact with the entire crane, and what deleterious effects can result from their improper performance. An aggressive routine of scheduled and preventive maintenance and repair must include all mechanical, electrical, and hydraulic systems, in addition to crane structures or areas exposed to high mechanical stresses.⁽⁶⁾

Certification

There is currently no federal U.S. standard requiring construction crane operators to be licensed or certified. Some states and cities, however, have instituted certification or licensing requirements, including California, Massachusetts, New York, Oregon, and the cities of Los Angeles, Chicago, Washington DC, and others.⁽²³⁾ Also, several organizations, including the National Commission for the Certification of Crane Operators (NCCCO) (started by the Specialized Carriers & Riggers Association and International Union of Operating Engineers) and the North American Crane Bureau Group (NACB), are developing private certifications. Other organizations, including the Society of Automotive Engineers, the Construction Industry Manufacturers Association, and the American Petroleum Institute, have made specific recommendations pertaining to crane operators.⁽²⁵⁾ The NCCCO has phased in a practical examination as part of their crane certification, which includes written and medical tests and the ability to document at least 1,000 hours of crane-related experience in the five years prior to the test. A core competence test and three specialty tests are available: one specific to lattice-boom cranes, one for telescopic boom cranes with capacities <17.5 tons, and one for telescopic boom cranes with capacities >17.5 tons.⁽²⁹⁾ The Canadian province of Ontario instituted a certification program in 1979 that has apparently resulted in fewer crane-related accidents and injuries in the construction industry, although the mechanism of this reduction has not been demonstrated. From 1978, the year in which the certification program went into effect, to 1995, the construction crane fatality rate decreased from 3.59 per year to 1.40 per year, providing some evidence that certification helps prevent catastrophic accidents.^(23,30) While certification is currently not mandatory for the majority of crane operators in the United States and Canada, it seems likely that if one or more certifications become popular among crane operators or companies utilizing cranes, more operators will need to become certified in order to get or keep employment. NACB claims to have administered over 400,000 operator evaluations since 1987.⁽³¹⁾

The International Union of Operating Engineers (IUOE), which represents 270,000 U.S. operating engineers,⁽³²⁾ including a large number of crane operators, began promoting the concept of crane operator certification in the 1970s, and has recently issued a formal resolution supporting certification.⁽³³⁾ On February 26, 1999, the IUOE, as a charter member of the NCCCO, was a signatory in a voluntary agreement with OSHA in which

OSHA agreed to recognize certifications awarded by the NCCCO. This agreement does not involve formal legal recognition of the certification, but signifies that the NCCCO certification will be considered an indicator of professional competence⁽³⁴⁾ (personal communications with Joe Brady, IUOE Director of Communications). This voluntary agreement may represent an important first step towards the implementation of a regulatory recognition and requirement of crane operator certification.

Regardless of the form of, or agency administering, crane operator certification, certain aspects of crane operation must be considered. Certifications must be specific to types and models of cranes, must cover a specifically defined range of duties, must involve an applied skill test in addition to a written knowledge test, must have an integral and defined skill level, must be renewable and revocable, and must involve a medical examination.^(23,35)

OSHA requires that cranes be inspected annually by a competent person or private agency recognized by the U.S. Department of Labor. OSHA also requires that a competent person be responsible for inspecting crane equipment prior to and during use to insure safe operation, and that any deficiencies be corrected before continued use. The more comprehensive approach taken by some states requires that mobile cranes be certified annually, and that tower cranes be certified each time they are erected, even if they are only moved to a new location within a site.

Installation/Removal/Inspections

Tower cranes should be erected, raised, and dismantled under the immediate supervision of a competent person, and a professional engineer should certify that the crane foundations and underlying soil are adequate support for the crane's maximum overturning movement. Tower cranes should be able to rotate 360° without striking any object or structure; otherwise, they should be fitted with limit switches to reduce their range of rotation, or equipped with direct voice communications so a signalperson may notify the operator of objects in the crane's swing radius. New construction projects, including buildings and foundations, should be evaluated for their ability to withstand torque and pressure loading created by tower cranes prior to installation. Workers are frequently injured while dismantling lattice boom cranes by improperly supported booms that collapse after their retaining pins are removed. Workers should never work under improperly supported loads, such as a crane boom suspended only by its hoist line.

Few construction contractors own and operate a fleet of tower cranes; most are rented and operated by in-house or contracted personnel. For this reason, inspections before the initial operation of any tower crane, and throughout the use of the crane, are essential.⁽⁷⁾ Employers are responsible for maintaining records of inspection dates and results for all pieces of hoisting equipment; these records should be kept permanently. One important inspection that must be done is of the connection between a crane superstructure's turntable and the vehicle or structure below. If

this connection fails, the superstructure will undock (fall) from the carrier.⁽²³⁾

Communication

Communication provides an effective means for avoiding crane chassis or electrical failure due to accidental contact with nearby structures. Radio or other voice communication is critical for tower cranes, the crane type where the operator is most likely to be unable to see the load (i.e. during blind lifts and on very large cranes) and therefore forced to rely on riggers and signalmen.⁽⁶⁾ Tower and mobile cranes operated in such a way as to prohibit visual signal communication should be equipped with electrical or voice communication systems.

In addition to voice communication systems, hand signals are an excellent method for communicating with crane operators.⁽⁷⁾ A set of one- and two-handed signals is presented in the ANSI/ASME B30.x standards, and is required during crane operations by OSHA. An illustration of these signals needs to be posted on-site.

Electrical Procedures

Electrical safety procedures reduce the risk of electrical crane failure. In many documented crane-related electrocutions the procedures below are not followed.⁽¹⁵⁾ Where it is difficult for the crane operator to maintain safe clearance visually, OSHA requires that a person be designated to observe power line clearance and to give immediate warning when the crane approaches the safe clearance limits. OSHA further requires de-energized powerlines be visibly grounded at the point of work.

OSHA specifies that for construction work around lines rated 50 kV or below, the minimum clearance between the lines and any part of the crane or load must be 10 ft; for lines above 50 kV, the minimum clearance must be least 10 ft plus 0.4 inch for each kilovolt above 50, or twice the length of the line insulator (but never less than 10 ft). ANSI recommendations are more protective, requiring a minimum clearance of 10 ft, with an additional 5 ft clearance for every additional 150 kV of line energy up to 750 kV, and an additional 10 ft clearance for voltages between 750–1000 kV. Special precautions must be taken during crane operations near transmitter towers to dissipate any induced current, as crane booms or materials being handled may act like antennas and pick up electrical charges from nearby communications equipment.⁽²⁷⁾

CRANE SAFETY RESPONSIBILITY

There are numerous different parties with responsibility for safe crane operations: crane manufacturers, crane rental companies, contractors and subcontractors, crane operators, riggers and signalmen,⁽²⁰⁾ crane associations, and standard-making organizations.

Crane manufacturers must design cranes capable of being safely operated by an adequately trained crane operator, that meet all applicable safety and design standards, that are easily maintained, and that address typical human factors problem

areas such as control design. One effective way to do this is to insure that crane controls are relatively uniform in appearance and operation; this can significantly reduce potential operator confusion. The Construction Safety Association of Ontario and other organizations have recommended in the past that crane controls be designed in accordance with SAE standard 1983; however, this standard is now nearly 20 years old and outdated.^(25,27) Manufacturers should also actively monitor the field performance of their cranes, and maintenance/spare part requests to assess whether any design aspect might be contributing to product failures or problems.

Crane rental companies need to provide equipment that meets appropriate standards and is well maintained. The records surrounding each crane (serial number, parts manual, maintenance schedule, modifications, etc.), must be maintained for the lifetime of the crane.⁽²³⁾

Although crane equipment is usually leased from a third party, the employer renting the equipment has the responsibility to ensure the crane is in proper operating condition. Therefore, construction contractors and subcontractors need to have effective crane safety inspection procedures in place and must notify the crane rental company and manufacturer when problems are identified. In addition, all levels of contractor management in companies utilizing cranes must be committed to safe crane operations and must follow safe lifting guidelines at all times, despite timeline pressures, which may encourage companies to limit the use of safe procedures.

Crane operators have the most direct influence on how safely cranes are operated. It is the responsibility of crane operators to restrict their operations to cranes with which they have attained technical and performance proficiency. An operator must never operate a crane in conditions that could compromise proper operation or mechanical integrity of the crane.

Associations of companies, labor, vendors, and individuals involved closely with crane operations provide an excellent forum for information exchange, training, and problem-solving. The Washington Crane Safety Association (WCSA) is one exemplary program initiated by the Washington Department of Labor and Industries after an accident in which three construction workers were killed by a crane collapse during repairs on Seattle's Kingdome stadium. WCSA has members from most of the Washington companies that own or operate cranes.

Standard-making organizations may be either regulatory or voluntary. These two types of organizations have different roles: regulatory agencies are responsible for promulgating and enforcing safety standards that typically involve minimum requirements for safe crane operations; conversely, voluntary standard-making organizations often design and promote standards that go far beyond minimum requirements.

SOLUTIONS AND OPPORTUNITIES

Cranes are an integral part of most construction projects, which, when properly operated, contribute substantially to the efficient progress of work, but which also have the potential

to cause enormous loss of life and property. There are a large number of safety devices and procedures designed to reduce the potential for crane accidents; however, the number of injuries and fatalities associated with cranes remains high. There are a few possible reasons for this.

The first reason is the inherent complexity of the design and operation of construction cranes. A crane operator controlling a 200-ton load at the end of a 180-foot latticework boom must constantly monitor a vast number of operational parameters. Despite the presence of computerized crane sensors and radio contact with riggers and signalmen, it may be nearly impossible for any operator to attend to all the potential hazards involved in a crane lift. In-depth review of all aspects of construction crane operations by competent and qualified crane experts may provide further information on, and possible solutions to, ongoing crane hazards that contribute to injuries and fatalities. These solutions may take the form of enhanced safety procedures and would also likely include re-engineering and improvement of the safety systems designed to prevent crane accidents. Given the numerous design and operational factors that can contribute to crane failure, any engineering efforts must take into account human factors interactions in addition to raw equipment performance. However, the development and implementation of additional active systems that prevent cranes from exceeding their safe performance envelope could potentially result in significant decreases in the number and severity of crane accidents by minimizing the opportunity for human-factors-related errors.

Another very important factor in crane safety, separate from equipment and procedural issues, is the competence and skill of the crane's operators and related personnel, such as riggers and signalmen. Mandatory certification of crane operators is very controversial, due to the large number of uncertified operators currently working in the industry. Although the recent certification recognition agreement between the NCCCO and OSHA is an important first step toward a formal certification procedure, it remains to be seen whether individual crane operators and crane employers will recognize the value of certification and choose to seek certified status. Despite the absence of a universally recognized certification process, operators and associated personnel nevertheless require adequate initial training specific to the types and models of cranes they are likely to operate, and retraining and repeated performance-based evaluations are essential to maintain a high level of skill and proficiency in the construction crane operator population.

Although an array of safety devices and procedures is currently available to crane users, the extent to which these mechanisms are utilized is unknown. Additional study is required to evaluate the use and effectiveness of these safety strategies in order to identify and correct deficiencies and reduce the number of construction injuries and illnesses resulting from working around cranes. Future research must take into account the interaction of a number of factors related to crane safety, including design and engineering, operator training, safety equip-

ment and procedures, and regulations. The high rates of construction injuries and fatalities associated with cranes clearly indicate that current safety procedures and devices are not completely effective in preventing accidents. Unfortunately, data are not available to evaluate the extent to which accidents result from failures in recommended processes or flawed procedures and/or equipment. Attributing the majority of crane failures to operator error is a tempting way to avoid in-depth examination of the fundamental causes of accidents; it also ensures that these failures will continue to occur. Only with additional research can the true sources of these accidents be identified and corrected.

In addition to further review of crane safety systems design, increased training requirements, and frequent inspection by crane specialists, future research needs to address the magnitude of the crane injury problem. Epidemiologic data are particularly difficult to obtain given the problem of defining worker "exposure" to crane systems. Studies using case-control or case-control/crossover designs may provide new insights into important risk factors for crane-related injuries or deaths, as well as other construction industry problems. More effective surveillance systems are also required to identify the frequency with which cranes and other mobile equipment are associated with the toll of construction industry injuries.

ACKNOWLEDGMENTS

The authors wish to thank Mike Beus at the National Institute for Occupational Safety and Health Spokane Research Center for his support of this publication, and Janice Camp of the University of Washington Department of Environmental Health, and Rick Gleason of Prezant Associates, Inc., in Seattle, WA, for reviewing the publication.

REFERENCES

1. Rivara, F.P.; Alexander, B.H.: *Occupational Injuries in Clinical, Occupational, and Environmental Medicine*. Saunders, Philadelphia (1994).
2. MacCollum, D.V.: *Crane Hazards and Their Prevention*. American Society of Safety Engineers, Des Plaines, IL (1993).
3. Shapiro, L.K.; Shapiro, H.I.: *Construction Cranes*. *Scientific American* 258:72-79 (1988).
4. OSHA Website: *Census of Fatal Occupational Injuries 1994-95* (<http://www.osha.gov/oshstats/bls/pdfs/cftb0056.pdf>), visited May 18, 1999.
5. Coutts, N.G.B. (ed.): *Real Power Lifting at Boston's "Big Dig."* *The International Operating Engineer*. Dec 1998-Jan 1999, 141:24.
6. Cerny and Ivey Engineers, Inc. *Web Site. Crane Safety Newsletter, Volume 41* (<http://www.mindspring.com/~cieinc/newslett.htm>), 1999.
7. National Safety Council. *Accident Prevention Manual for Business and Industry: Engineering and Technology*. 10th ed. National Safety Council: U.S.A. (1992).
8. OSHA Strategic Plan FY1997-FY2000, *Crane and Hoist Safety*, 1996.

9. Bureau of Labor Statistics Web Site. 1998-99 Occupational Outlook Handbook: Material Moving Equipment Operators (<http://stats.bls.gov/oco/ocos243.htm>), visited May 16, 1998.
10. Veazie, M.A.; Landen, D.D.; Bender, T.R.; Amandus, H.E.: Epidemiologic Research on the Etiology of Injuries at Work. *Ann Rev Public Health* 15:203-221 (1994).
11. Pratt, S.G.; Kisner, S.M.; Moore, P.H.: Machinery-Related Fatalities in the Construction Industry. *Am J Ind Med* 32:42-50 (1997).
12. Health and Safety Executive. One Hundred Fatal Accidents in Construction. Her Majesty's Stationary Office: London, England (1978).
13. Suruda, A.; Egger, M.; Liu, D.: Crane-Related Deaths in the U.S. Construction Industry 1984-94. The Center to Protect Workers' Rights (Report No. D2-97) (1997).
14. Hinze, J.; Bren, D.: Analysis of Fatalities and Injuries Due to Powerline Contacts. *Journal of Construction Engineering and Management* 122(2):177-182, June (1996).
15. National Institute for Occupational Safety and Health (NIOSH). NIOSH Alert: Preventing Electrocutions of Crane Operators and Crew Members Working Near Overhead Power Lines. 1995 (DHHS/NIOSH Publication No. 95-108).
16. National Institute for Occupational Safety and Health (NIOSH). Fatal Injuries to Workers in the United States 1980-1989: A Decade of Surveillance, (DHHS/NIOSH Publication No. 93-108) (1993).
17. Sorock, G.S.; Hagen Smith, E.; Goldoft, M.: Fatal Occupational Injuries in the New Jersey Construction Industry, *J Occ Med* 35:916-921 (1993).
18. Hakkinen, K.: Crane Accidents and Their Prevention. *J Occup Accidents* 1:353-361 (1978).
19. MacCollum, D.V.: Critical Hazard Analysis of Crane Design. *Professional Safety* 24:31-36 (1980).
20. Jarasunas, E.K.: Crane Hazard Prevention. *Hazard Prevention*, March-April, 9-11 (1987).
21. Suruda, A.: Electrocution at Work. *Prof Safety* 27-32, July 1988.
22. Janicak, C.A.: Occupational Fatalities Caused by Contact with Overhead Power Lines in the Construction Industry. *J Occ Env Med* 39:328-332 (1997).
23. MacCollum, D.V.: *Construction Safety Planning*. Van Nostrand Reinhold: New York (1995).
24. St. Paul Fire and Marine Insurance Company. Mobile Crane Program: 4-Hour Training Course.
25. Brauer, R.L.: *Safety and Health for Engineers*. Van Nostrand Reinhold: New York (1990).
26. Dickie, D. (ed.): *Crane Handbook*. Construction Safety Association of Ontario. Toronto, Ontario, Canada. October 1975.
27. Worksafe Western Australia Web Site. Tractor Cranes: Safe Handling of Loads (<http://www.safetyline.wa.gov.au/PageBin/mechhazd0014.htm>). Oct 1, 1995.
28. Sale, Dwight B. (Ed.): *Crane Safety on Construction Sites*. Task Committee on Crane Safety on Construction Sites, Construction Division of the American Society of Civil Engineers. United States (1998).
29. Professional Safety. Crane Operator Commission Develops Practical New Exam. *Prof Safety* 44(4):13 (April 1999).
30. National Commission for the Certification of Crane Operators. Pamphlet: Crane Operator Certification: Answers to Your Questions (1996).
31. North American Crane Bureau Group, Inc. Web Site. Why Certify? (<http://www.cranesafe.com/certific.htm>) (1999). Visited February 8, 2000.
32. Stern, F.; Haring-Sweeney, M.: Proportionate Mortality Among Unionized Construction Operating Engineers. *Am J Ind Med* 32:51-65 (1997).
33. International Union of Operating Engineers. Occupational Safety and Health Resolution No. 7: Crane Operator Certification. 35th General Convention of the International Union of Operating Engineers, Lake Buena Vista, FL, April 27, 1998.
34. Coutts, N.G.B. (ed.): Crane Operator Certification Agreement Signed. *The International Operating Engineer*. February-March 1999, 142:2.
35. Washington State Crane Safety Association. Training and Seminar Committee: Recommended Guideline for the Qualification and Training of Mobile and Locomotive Crane Operators in the State of Washington. October 3, 1997.

APPENDIX A

Overloading—Combination of boom length, angle, and lifted load that exceeds the rated capacity and safety margin of a crane and results in a crane upset

Side Pull—Lateral boom loading encountered when a load is turned or lifted can buckle the boom

Outrigger Failure—Outriggers fail to keep crane stabilized, or are never deployed to begin with

Hoist Limitations—Hoist line parts while being reeled in or suspending a load

Two-Blocking—Load is lifted too high and the hook block strikes the boom tip

Killer Hooks—Worn hook fails and drops a load unexpectedly

Boom Buckling—Boom deformation due to suddenly applied strains (i.e. abrupt release of a load, raising the boom beyond a safe angle, boom striking a structure), or compromise during shipping

Upset/Overturn—Due mainly to operator failure to extend outriggers, although also possible while moving a load on unstable/uneven terrain

Unintentional Turntable Turning—Load is lifted without operator locking cab onto chassis

Oversteer/Crabbing—Can occur in some rough terrain cranes where rear wheel steering can be engaged accidentally, resulting in an unexpected halving of the crane's turning radius

Control Confusion—Can occur due to lack of control standardization among different crane makes and models, or insufficient distance and illogical placement of controls

Access/Egress—Footholds allowing operators to access the cab are frequently located in areas where hydraulic leaks occur, resulting in slippery footrests and subsequent falls

Unintentional Power Line Contact—Accidental contact between line and boom or crane chassis

Improper Assembly/Dismantling—Workers can become trapped between crane sections or fall from heights while installing crane components

- Rigging Failure/Fall of Load or Lifting Tackle/Rope or Fitting Failure*—May be due to poor rigging practices or failed rigging materials
- Being Struck by Moving Load*—Crane operators and nearby personnel struck by loads in transit
- Being Struck by Crane Itself*—Personnel working near cranes can be struck by the crane’s superstructure, boom, or vehicular chassis
- Unstable Ground Support/Non-Leveled Cranes*—Unleveled cranes are prone to tipping with, and sometimes even without, a lifted load
- Lifting Unknown Loads*—Can result in crane upset or boom failure
- Signaling or Rigging Errors*—Signaling errors may result in misguided crane movements and crane/object contact, while rigging errors can result in a dropped load or boom failure