

A Review of Power Quality Conditioners for Different Power Quality Issues

Rana Urvesh Rameshbhai
*Phd Scholar, Electrical
Engineering*
Gujarat Technological University
Ahmedabad , India
urvesh.rana@gmail.com

Bohra Shabbir Saleh
Electrical epartment
Sarvajanik College of Engineering
and Technology, Surat, India
shabbir.bohra@sctet.ac.in

Abstract— In today's scenario, due to proliferation and increasing use of power electronic devices, in power distribution system has been experiencing number of power quality problems like harmonics, voltage sag, voltage swell, etc. to great extent. To mitigate these power quality problems many devices like active power filter, dynamic voltage restorer (DVR), D-STATCOM, unified power quality conditioner (UPQC) are used. In this paper suitability of different devices for different power quality issues are shown.

Keywords — Harmonics, Power Quality, Voltage Sag, Voltage Swell, Active Power Filter (APF) etc.

I. INTRODUCTION

Power Quality is a broader term and encompasses set of electrical properties which is responsible for the proper function of the electrical system. The poor power quality refers to the deviation in supply parameters (voltage and frequency) from the ideal or prescribed limits. Thus, poor power quality includes voltage sag, voltage swell, frequency variations, transients, harmonics, flicker, imbalance in the three phases, interruption of supply, etc.[1]

To address the power quality problems, many corrective actions are to be taken by the utility as well as by the consumers, especially industrial consumers. Traditionally, passive LC filters were used to limit the injection of harmonics into the utility. These filters are now being replaced by the advanced power electronics compensator known as active power filters in the modern electrical power system. Out of the various active power filter configurations (series, shunt and hybrid), shunt active power filter (SAPF) is quite popular to eliminate harmonics locally at the load side making the utility free of harmonics. Unlike passive LC filters, which are simple in design, inexpensive, larger in volume and bulky, tuned to particular frequency; the APFs are complex and expensive;

however, relatively compact, quick, free from problem of resonance, and adaptive in nature. And hence, it can compensate various harmonics caused different types of non-linear loads.[1]

APF Technology is now effective for providing compensation for harmonics, reactive power and other issues in AC system. APF is also used to eliminate voltage harmonics,

To suppress voltage flicker and to improve voltage balance in three phase system. An objective is to achieve depending upon the control strategy and configuration which have to be appropriately suitable.[1]

II. CONFIGURATION

APF can be classified based on different types like its converter, topology, control strategy being adopted, selection of component and other essential additional features:

A. Converter Based

There are two types of converters being used in active filter. PWM inverter is used in this topology. It behaves as a non sinusoidal current source to meet harmonic current due to non linear load.

The PWM converter is responsible for power processing and the active filter controller is signal processing unit . Figure 1 the basic configuration of shunt active filter use for the compensating of harmonics

Figure 2 shows block diagram of series active filter. It is connected before load in series with ac mains to eliminating voltage harmonics and to balance and regulate voltage of line. It has been used to reduce negative sequence voltage. It can be installed by electric utilities to compensate voltage harmonics[1].

Figure 3 shows hybrid filter which is combination of active and passive filter. In hybrid filter LC passive filter is used to eliminate lower order harmonics. Hybrid filter is classified in four categories: (i) shunt active filter with series passive filter (ii) series active filter with shunt passive filter (iii) series active filter with series passive filter (iv) shunt active filter with shunt passive filter [1].

The first type is suitable for voltage source type of loads. Series active filter provides isolation between source and shunt passive filter by restricting all the load current flowing into the passive filter. The disadvantage of this method is that series active filter is connected between supply and load through series transformer, which requires great protection so cost of protection is high.

In second type, active filter increases the performance of shunt passive filter. In this type protection and control is easy rating of active filter is low because of series connection with passive filter. The drawback of this type is that reactive power control and thus is less preferred.

Shunt hybrid filter operates as current source and harmonic sink. Shunt active filter eliminates lower order harmonics like 5th and 7th while shunt passive filter eliminates high order harmonics like 11th, 13th etc. and thus shunt hybrid filter is effective solution to eliminate load current harmonics as it is able to remove low order as well as high order harmonics.

Passive filter is used to eliminate particular order harmonics and active filter controller consists of control circuit. So, the rating of inverter is reduced. The inductor, L is

produce by nonlinear load. It consists of voltage source inverter with the PWM current control. Active filter controller consist the current control algorithm.[1][2][3]

The PWM converter operates at high switching frequency. The DC link capacitor and IGBT with anti-parallel diode form the voltage source inverter. The firing pulses of VSI are generated from PWM control. The Active shunt filter continuously senses the load current I_L , and calculate the instantaneous current I_c to take corrective action.

B. Topology Based

APF can be classified based on topology used as a series or shunt active filter and unified power quality conditioner. The careful amalgamation of active filter and passive filter is known as hybrid filter which is mostly used to eliminate current harmonics, facilities reactive power compensation (an excellent example is D-STATCOM) and balancing unbalanced current

used to reduce di/dt ratio across switches in inverter. The active filter controller produces control signal. This control signal is compared with carrier wave in PWM to produce gate pulses. These gate pulses are released to the inverter.

C. Control Strategy Based

Control strategy plays a vital role in performance of active filter technology. Control methods of active filter in time domain are instantaneous derivation of compensating command in form of either voltage or current at point of common coupling. Conventionally, instantaneous power $p-q$ theory, reference frame theory, sliding mode control [2] or fuzzy logic controller are used to implement control strategy of an active filter.

The instantaneous power theory ($p-q$ theory) was proposed by Hirofumi Akagi. in 1983. The $p-q$ theory is based on conversion of $a-b-c$ coordinate into $\alpha-\beta-0$ coordinates and $\alpha-\beta-0$ coordinates into $a-b-c$ coordinates, known as Clark's transformation and inverse transformation, respectively. The constant power compensation control strategy for a shunt active filter was the first strategy for a shunt active filter. It was the first strategy developed based on the $p-q$ theory, and was first introduced by H. Akagi in 1983 [1]. In terms of real and imaginary power in order to draw constant instantaneous

power from the source, the shunt active filter should be installed as close vicinity as possible to the non-linear load and should compensate the oscillating real power of the load.

Here, an assumption of a three phase system without neutral wire is being considered and therefore the zero sequence power is zero[1][3][4].

If the shunt active filter compensates the oscillating real power and imaginary power of the load, it guarantees that only a constant real power is drawn from the power system. Therefore constant instantaneous power control strategy provides optimal compensation from a power flow, even under non-sinusoidal or unbalanced system voltages[4][9].

Hysteresis current control technique is basically an instantaneous feedback current control method of PWM, where the actual current continually tracks the command current within a hysteresis band. In active power filter, hysteresis current control (HCC) method is used to generate switching pulses to drive the six switches of three phase voltage source inverter. In this technique the actual output currents of active filters are compared with the reference current. If the difference between actual current and reference current exceeds the upper hysteresis band limit than upper switch becomes on and lower switch is turned off and if the difference between actual current and reference current exceeds the lower hysteresis band limit than upper switch goes off and lower switch is turned on.[1][5][6][7]

Fuzzy system is based on fuzzy set theory and associated techniques are proposed by Zadeh. Fuzzy inference is the

process of formulating the mapping from a given input to an output using FL. The mapping then provides a basis input-output for making decisions. The process of fuzzy inference involves Membership function, logical operators, and *IF-THEN* rules. The function that defines how each element is mapped to the degree of membership is called Membership function. Fuzzy system has four components they are Fuzzification, fuzzy rule, inference engine, and De-fuzzification. Fuzzification is a process that converts numerical measurements into fuzzy sets. The fuzzy rule is generated by the training algorithms via input-output data pairs and the rules are expressed in the *IF THEN* form reasoning[13][14].

D. Generating Firing Pulses for APF

To generate gate signals for AF based on the derived compensating quantity. Hysteresis band control, PWM voltage control or PWM current control are used to generate firing pulses for active filter. Generally sinusoidal pulse width modulation technique is widely used to generate gate pulses for power circuit for AF [10][11].

Unified power quality conditioner, which is combination of active shunt filter and active series filter shown in figure 4. DC link capacitor is shared between series and shunt active filter. It is used to mitigate current and voltage harmonics as well. It can balance and regulate voltage and eliminate negative sequence current. Its main drawbacks are its size, cost and control complexity [1] [12][13][14][15][16].

E. Figures and Tables

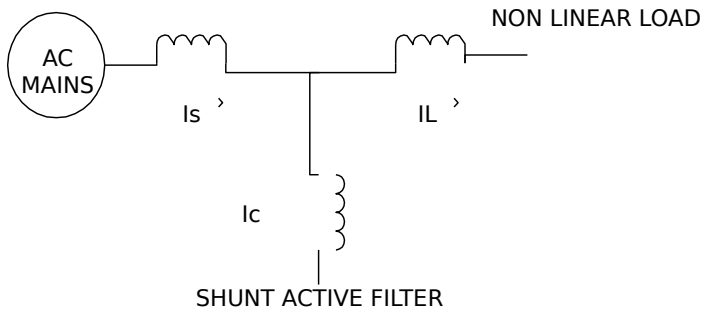

Fig. 1 Shunt Active Filter

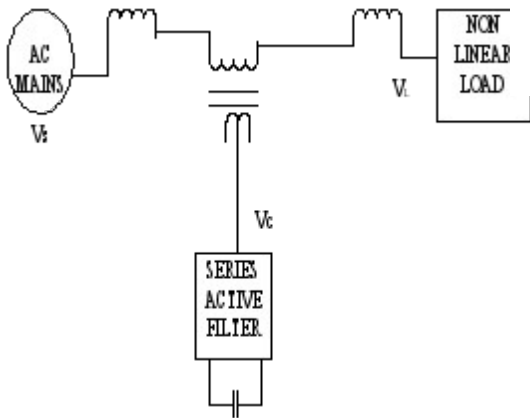

Fig. 2 Series Active Filter (APF)

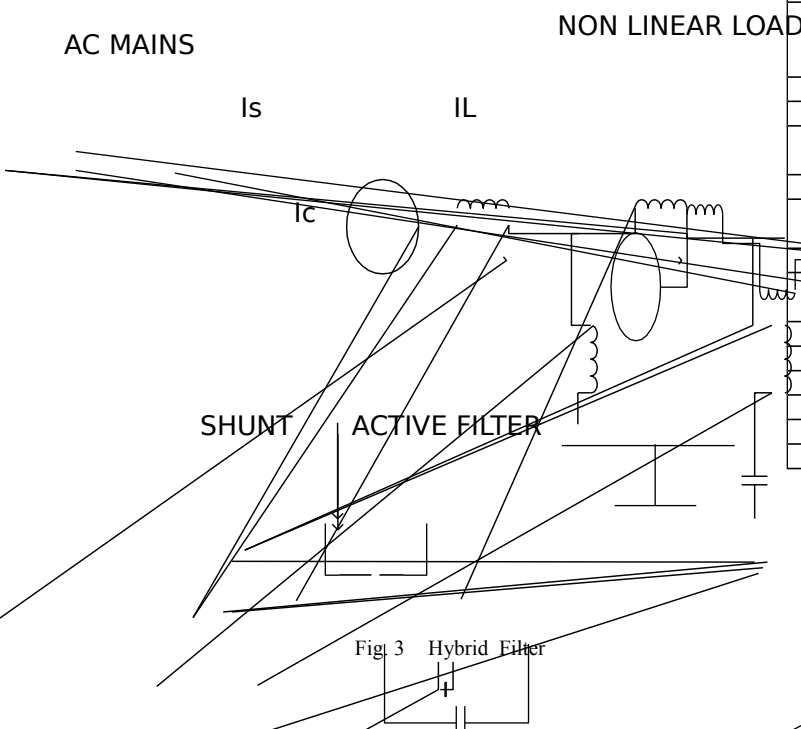

Fig. 3 Hybrid Filter

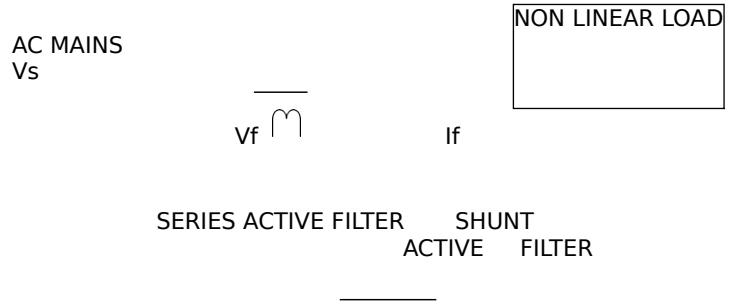

Fig. 4 Unified Power Quality Conditioner (UPQC)

TABLE I. POWER QUALITY PROBLEMS AND THEIR PREFERABLE SOLUTIONS

Sr. No	Power Quality Issues	Series Active Filter (DVR)	Shunt Active Filter DSTATCOM	Hybrid Filter (Active Series + Passive filter)	Hybrid Filter (Active Shunt + Passive filter)	UPQC
1	Current Harmonics		***	*	***	**
2	Reactive Power		***		**	**
3	Load Balancing		*			*
4	Neutral Current		**	*		*
5	Voltage harmonics	***		***	*	**
6	Voltage Regulation	***		**		**
7	Voltage Balancing	***		**		*
8	Voltage Flicker	**	***		*	*
9	Voltage Sag and Swell	***		*		*
10	(1 + 2)		***		***	***
11	(1 + 2 + 3)		**		**	**
12	(1 + 2 + 3 + 4)		**	*	**	**
13		**	*	**	*	**
14	(5 + 6 + 8)	**	*	*	*	*
15	(1 + 5)	*	*	*	*	***
16	(1 + 2 + 5 + 6)	*	**	*	*	**
17	(6 + 7)	**		**		*
18	(2 + 3)		*		*	*
19	(2 + 3 + 4)		*		*	*
20	(1 + 2 + 7)	*	**	*	**	**
21	(1 + 3)		**		**	**
22	(1 + 4 + 7)	*	*	*	*	*

Note: more the number of * better its suitability

CONCLUSION

This paper explains types, suitable, efficient active power filter, hybrid filter, unified power quality conditioners, etc. Table-I mentions suitable power quality devices for different power quality issues. Role of active power filter is multifaceted, *i.e.* suitable for harmonic mitigation, reactive power compensation, eliminate negative sequence current. Series active filter- dynamic voltage restorer or DVR is most suitable in voltage sag and voltage swell problem and also for voltage quality mitigation. Unified power quality conditioner is most suitable for most of power quality issues but its drawbacks are its complexity and higher cost[1].

ACKNOWLEDGMENT

I would like to express my appreciation towards my parent institute, Parul Institute of Technology (PIT), for providing all kind of technical and nontechnical support for my research work. Special thanks is needed for the Department of Electrical Engineering, PIT that has provided me the moral support.

REFERENCES

- [1] Hirofumi Akagi , Edson Hirokazu Watanabe , Mauricio Aredas “Instantaneous Power Theory and Applications to Power Conditioning” IEEE Press, John and Willey and Sons Publication.
- [2] Rudranarayan Senapati, Rajesh Kumar Sahoo, Sonakshi Pradhan, Rajendra Narayan Senapati, “Sinusoidal Current Control Strategy for 3-Phase Shunt Active Filter in Grid-tied PV System,” International Conference on Energy, Communication, Data Analytics and Soft Computing (ICECDS-2017), 978-1-5386-1887-5/17/\$31.00 ©2017 IEEE , Page : 1272-1277
- [3] A. Elallali* , A. Abouloifa. C. Taghzaoui, Y. Mchaouar, A. Hamdoun, I. Lachkar,” Nonlinear Control of a Single Phase Shunt Active Filter Connected Photovoltaic Systems via Sliding Mode” 2018 5th International Conference on Electrical and Electronics Engineering, 978-1-5386-6392-9/18/\$31.00 ©2018 IEEE, Page : 56-61
- [4] Ms.Priyanka S. Salunkhe, Prof.Mrs. Shruti Gaur , Prof. Mr. M.R. Hans “Implementation Of Shunt Active Power Filter to Mitigate Harmonics,” 2nd International Conference on Communication and Electronics Systems (ICES 2017) ISBN:978-1-5090-5013-0, Page : 814-818.
- [5] Anand Panchbhai, Shreya Parmar, Nikunj Prajapati “Shunt Active Filter for Harmonic And Reactive Power Compensation Using p-q Theory,” 2017 International Conference on Power and Embedded Drive Control (ICPEDC) , 978-1-5090-4679-9/17/\$31.00 c 2017 IEEE , Page :260-264
- [6] J Femila Roseline, Nikhil Kumar Sahoo, Ayush Abhinav “Implementation of Fuzzy Logic in shunt Active Power Filter for Renewable Power Generation System,” 2016 Second International Conference on Science Technology Engineering and Management (ICONSTEM) , 978-1-5090-1706-5/16/\$31.00 ©2016 IEEE, Page : 451-456
- [7] Unnikrishnan S, Prof. Biji G, “Hybrid Series Active Power Filter for Mitigating Power Quality Problems,” International Conference on Energy, Communication, Data Analytics and Soft Computing (ICECDS-2017), 978-1-5386-1887-5/17/\$31.00 2017 IEEE , Page :811-816
- [8] Manitha P.V, Raji S, Manjula G. Nair , “Performance Analysis of Different Control Algorithms for Series Active Filter”, [2015 IEEE International Conference on Electrical, Computer and Communication Technologies \(ICECCT\)](#), 978-1-4799-6085-9/15/\$31.00 ©2015 .
- [9] Amarjeet kumar, A.A. Bhole,” Design of Hybrid Filter for Elimination of Current Harmonics “ , 2017 2nd IEEE International Conference On Recent Trends in Electronics Information & Communication Technology (RTEICT), May 19-20, 2017, India , 978-1-5090-3704- 9/17/\$31.00 © 2017 IEEE , Page :1337-1343.
- [10] Asim Abdullah, Gyan Ranjan Biswal, Amit Kumar Roy,” Modeling and Control of Hybrid Power Filter using p-q Theory”, 1st IEEE International Conference on Power Electronics, Intelligent Control and Energy Systems (ICPEICES-2016), 978-1-4673-8587-9/16/\$31.00 ©2016 IEEE , Page : 1-6.
- [11] Soumya Ranjan Das, Prakash. K. Ray, Asit Mohanty, Enhancement of Power Quality Disturbances using Hybrid Power Filters “ , 2017 International Conference on circuits Power and Computing Technologies [ICCPCT] , 978-1- 5090-4967- 7/17/\$31.00 © 2017 IEEE
- [12] Saurabh S.Jadhao, Gajanan P. Ratnaparkhi , Dr. G.M.Dhole, Dr. S.R. Paraskar,” Voltage Quality Enhancement using Unified Power Quality Conditioner (UPQC) “,International Conference on Energy, Communication, Data Analytics and Soft Computing (ICECDS-2017) , 978-1-5386-1887-5/17/\$31.00 ©2017 IEEE , Page :3270-3274
- [13] Satyanarayana Vanapalli, M. Venu Gopala Rao, S. Prabhkar Karthikeyan , “Performance Analysis of Unified Power Quality Conditioner Controlled with ANN and Fuzzy Logic based Control approaches” , 2017 IEEE Region 10 Conference (TENCON), Malaysia, November 5-8, 2017 , 978-1-5090-1134-6/17/\$31.00 ©2017 IEEE , Page : 1337-1342.
- [14] Anupam Kumar , Dr. A.H.Bhat , Shubhendra Pratap Singh , “Performance Evaluation of Fuzzy Logic Controlled Voltage Source Inverter Based Unified Power Quality Conditioner for Mitigation of Voltage and Current Harmonics”, 2016 Intl. Conference on Advances in Computing, Communications and Informatics (ICACCI), Sept. 21-24, 2016, Jaipur, India , 978-1-5090-2029-4/16/\$31.00 @2016 IEEE , Page : 1799-1804.
- [15] Monika Deshpande , Tanuja Date , “Unified Power Quality Conditioner for Three phase Four Wire Distribution System” , IEEE Sponsored 2nd International Conference on Innovations in Information Embedded and Communication Systems ICIECS’15 , 978-1-4799-6818-3/15/\$31.00 © 2015 IEEE .
- [16] Arpit Agrawal , Pramod Agarwal , Premalata Jena , “Compensation of Voltage flicker using Unified Power Quality Conditioner (UPQC) “ , 2014 IEEE International Conference on Power Electronics, Drives and Energy Systems (PEDES) , 978-1-4799-6373-7/14/\$31.00 ©2014 IEEE