

**CASE FILE  
COPY**

**N 7 1 - 3 3 2 4 8**

**NASA TM X- 67900**

**NASA TECHNICAL  
MEMORANDUM**

**NASA TM X- 67900**

**A REVIEW OF SURFACE SEGREGATION, ADHESION AND FRICTION  
STUDIES PERFORMED ON COPPER-ALUMINUM,  
COPPER-TIN AND IRON-ALUMINUM ALLOYS**

by John Ferrante and Donald H. Buckley  
Lewis Research Center  
Cleveland, Ohio

**TECHNICAL PAPER** proposed for presentation at  
Lubrication Conference sponsored by the American Society of Lubrication  
Engineers and the American Society of Mechanical Engineers  
Pittsburgh, Pennsylvania, October 5-7, 1971

A REVIEW OF SURFACE SEGREGATION, ADHESION AND FRICTION  
STUDIES PERFORMED ON COPPER-ALUMINUM,  
COPPER-TIN AND IRON-ALUMINUM ALLOYS

by John Ferrante and Donald H. Buckley

Lewis Research Center  
National Aeronautics and Space Administration  
Cleveland, Ohio

ABSTRACT

E-6385  
A review of the results of Auger emission spectroscopy, low energy electron diffraction, adhesion and friction experiments on a number of alloys is presented (1). The alloys discussed are single crystals oriented in the (111) direction, of Cu-10 a/o Al, Cu-5 a/o Al, Cu-1 a/o Al, Cu-1 a/o SN and a polycrystalline sample of Fe-10 a/o Al. In all cases the minor constituent segregated at the surface in quantities much higher than the bulk concentration producing markedly altered adhesion and friction behavior. The observations in these studies indicate that bulk compositions should not be assumed to hold in experiments involving surfaces.

INTRODUCTION

Many friction, wear and lubrication studies are performed on materials which are either alloys or have relatively high bulk concentrations of contaminants such as carbon. The assumption is often made that bulk properties reflect surface effects. In the past ten years, the ability to characterize surfaces has advanced greatly. LEED (low energy electron diffraction) (1) has been used to examine changes in the surface structure of single crystals. AES (Auger emission

spectroscopy) (Refs. 2 and 3) has been used to determine surface composition both qualitatively and quantitatively. The ability now exists to examine to what degree bulk composition reflects surface structure and composition.

The present paper reviews results observed by Buckley and Ferrante (4, 5, 6, 7) on several alloys systems - single crystals of Cu-1 a/o Al, Cu-5 a/o Al, Cu-10 a/o Al, Cu-1 a/o Sn and polycrystalline Fe-10 a/o Al. Since some of these results are not in the open literature or are directed towards readers not in the friction and wear field, the objective of this review is to summarize these papers for researchers in friction and wear. AES, LEED, adhesion and friction experiments were performed on these samples combined with sputtering studies. The results of the studies demonstrate that bulk conditions do not reflect surface conditions, in that in each case the minor constituent segregated at the surface. In addition, friction and adhesion data indicate effects that are much larger than would be expected from bulk concentrations. A model for surface segregation mechanisms is also discussed (6, 8).

#### MATERIALS USED IN THE STUDIES

The copper-aluminum (4, 5, 6) crystals studied were cylinders varying from 0.6 to 0.8 cm both in radius and height. The copper-tin crystals were rectangular prisms 1.2×0.85×0.5 cm. Both were oriented in the (111) direction. The copper-aluminum crystals were substitutional solid solutions having 1, 5, and 10 a/o aluminum in copper. The copper-tin crystal was a solid solution with 1 a/o tin in copper. The crystals,

triple-zone refined, contained no more than 10 ppm impurities. Pure aluminum and copper crystals were used as standards for the AES studies. The crystals were polished to 600 grit on metallurgical papers and then electropolished in orthophosphoric acid.

The iron-aluminum alloys studied (7) were polycrystalline solid solutions made by vacuum melting from 99.99 percent iron and 99.99 percent aluminum. The Fe alloys were machined into discs and pins used in the friction experiments. These samples were given a final polish with alumina in water.

A disc of iron -10 a/o aluminum was used for the AES studies. This sample was electropolished in orthophosphoric acid before mounting in the vacuum system. High purity research grade argon was used for sputtering the crystals.

#### DESCRIPTION OF APPARATUS

The apparatus used for the AES-LEED and Adhesion studies is shown in Fig. 1. The specimen studied could be rotated  $360^{\circ}$  allowing AES, LEED, and adhesive contact analyses as well as ion bombardment cleaning. The vacuum system consisted of sorption pumps, an ion pump and a sublimation pump, which enabled obtaining system pressures of  $2 \times 10^{-10}$  torr when data were taken.

Friction experiments on the iron-aluminum alloys were performed in the rider-disc apparatus shown in Fig. 2 (7). Riders and discs were formed from the same material. The plexiglass box containing the friction apparatus was continuously purged at a positive pressure with dry argon.

## SUMMARY OF EXPERIMENTAL PROCEDURES USED IN OBTAINING RESULTS

The surfaces of all samples used in the AES-LEED studies were cleaned by first outgassing at 500<sup>o</sup> C until the system pressure reached the 10<sup>-10</sup> torr range and then by alternately sputtering and heating until the principal impurity peaks—carbon, sulfur, and oxygen—were removed from the AES spectrum. Sputtering for cleaning was performed with 600 ev argon ions at an approximate current density of 5×10<sup>-6</sup> amps/cm<sup>2</sup>. Fig. 3 shows the results of sputtering on surface cleaning. Note that the principle contaminant peaks of carbon, oxygen, and sulfur could be reduced considerably by sputtering.

In order to demonstrate surface segregation, the same procedure was used for all of the alloys. The alloys were first sputtered for long times removing many layers. Following sputtering, an AES trace was taken. The crystals were then heated at temperatures ranging from 100<sup>o</sup> C to 700<sup>o</sup> C and following heating the crystals were allowed to cool to room temperature. AES traces were then taken in regions which displayed the peaks of interest. A typical example of these measurements is shown in Fig. 4 for the copper-10 a/o aluminum alloy. The Aluminum Auger peak in this figure increased greatly relative to the copper Auger peak, indicating an increase of Aluminum in the region of the surface. LEED patterns were observed for these alloys at each step in the processing.

In addition, attempts were made to determine concentration versus depth for the copper-10 a/o aluminum alloy. The depth of increased concentration at the surface was estimated using the sputtering yield (number of atoms removed/incident ion) given by Langfried and

Wehner (9) for 400 ev argon ions (5, 6).

The adhesion experiments were performed by making contacts between the crystal of interest and a gold crystal oriented in the (111) direction mounted on the pivot arm shown in Fig. 1. For the copper-aluminum alloys (4, 5, 6) the crystals were first cleaned. Then, the amount of force necessary to break the bond resulting from a 20 mg load was determined. With the copper-1 a/o tin alloy the amount of force necessary to break the bond formed was determined following sputtering and following heating. The copper-tin results are new and do not appear in the cited references.

Friction coefficients (7) were determined for the iron-10 a/o aluminum alloy and pure iron with the rider disk apparatus, shown in Fig. 2. The experiments were performed with varying percentages of stearic acid in hexadecane as a lubricant. The load used was 250 g and the sliding velocity was 3.8 cm/sec.

## DISCUSSION OF RESULTS

### A. Surface Segregation

The results of the surface segregation studies are shown in Table I for all of the alloy systems studied. The alloys all show surface concentrations much higher than bulk concentration. Surface segregation occurred readily at 200<sup>o</sup> C in the copper systems. The iron system was checked only at 500<sup>o</sup> C, but it should behave similarly at 200<sup>o</sup> C. In interpreting these results, several assumptions were made. First, after sputtering and removing many layers (> 1350) the peak to peak amplitude of the minor constituent Auger peak is assumed

to reflect bulk concentration. Wehner (10) points out that this is a reasonable assumption. The peak to peak amplitude of the minor constituent Auger peak after heating is assumed to be linearly related to the post-sputtering amplitude (5, 6). This gave a means of calibrating concentration in the surface region. A discussion of the use of Auger spectroscopy for quantitative analysis can be found in the literature (2, 3).

LEED gave an independent means for checking surface changes. Fig. 5 gives LEED patterns and their interpretation for the copper-aluminum system. The Cu-1 a/o Al crystal (not shown) had no additional spots in its pattern. The Cu-5 a/o Al crystal had faint extra spots indicating a partially formed layer (11). The copper 1 percent-Sn crystal gave the same LEED pattern as the higher concentration Co-Al crystals. LEED patterns give the correct symmetrics for a surface, but distances appear as reciprocals.

Interpretation of the LEED pattern's (Fig. 6(c)) in terms of the true crystal structure suggests the minor constituent popping out onto the surface and diffusing to preferred locations on the surface. The LEED results agree with the AES results for surface coverage with the Cu-10 a/o Al sample. Assuming only two layers are being sampled by AES (2) following segregation and only one layer before, LEED observations would predict a concentration of 0.33 for the top layer and 0.1 for the next layer giving a total of 4.3 times which agrees well with the maximum coverage observed by AES. The copper-1 a/o tin crystal had the same LEED pattern with well-defined spots. Since the iron sample was polycrystalline, no well-defined LEED pattern could be

discerned. The results of controlled sputtering studies (6) on the Cu-10 at/o Al crystals also set two layers as an upper bound on the region of increased concentration.

Figure 6 shows the results of sputtering, heating to the indicated temperature for 30 minutes, and then cooling to room temperature and taking an Auger trace on the copper-aluminum alloys. Two features can be observed in these curves: first that the surface concentration depends on bulk concentration and second that the concentration saturates with temperature.

These and the previous observations lead to an interpretation of the results as equilibrium segregation at the surface. An analogy between surface segregation and grain boundary segregation (5, 6, 8) can be readily made. As McClean (8) describes for the grain boundary case, when the solute atom is large compared to the space available in the solvent, lattice strain results. This strain can be relieved by having the solvent occupy a less strained position in the grain boundary or on the surface in this case. In addition, there is another contribution to reducing the energy from valence interactions with the excess electronic charge in the grain boundary or on the surface. It should be pointed out that segregation of the minor component is the equilibrium condition, i. e., the condition of lowest free energy, and should be expected as the normal state of the surface. Sputtering in the experiments creates a nonequilibrium condition. However, at room temperature, diffusion is slow and consequently the approach to equilibrium is slow. Heating allows the surface to approach equilibrium rapidly. Heating and stresses (8) experienced in friction experiments



could also act as mechanisms promoting the rapid approach to equilibrium. McClean has an expression based on a statistical thermodynamic argument that describes the equilibrium grain boundary or surface concentration as a function of bulk concentration, temperature, and retrieval energy.

$$C_d = \frac{C_o e^{Q/RT}}{1 - C_o + C_o e^{Q/RT}} \quad (1)$$

where  $C_d$  is the fractional grain boundary or surface concentration of the solute.

$C_o$  is the fractional bulk concentration of the solute

$Q$  is the retrieval energy gained by segregation

$R$  is the gas constant, and

$T$  is the temperature.

The data shown in Fig. 6 is interpreted (5, 6) as representing the room temperature equilibrium concentrations. The saturation at high  $T$  reflects the fact that for  $T > 300^\circ \text{C}$ ,  $C_d \approx C_o$  and consequently no change is observed in what is precipitated onto the surface in the cooling process by heating to higher temperatures. The  $Q$  calculated for the three copper-aluminum samples (  $1150 \pm 300$  cal/mole for Cu-1 a/o Al,  $1020 \pm 290$  cal/mole for 5 a/o Al and  $1190 \pm 450$  cal/mole for 10 a/o Al ) are in reasonable agreement with each other. These values are smaller than the strain energy in the bulk (6) but this is to be expected. The aluminum in iron and the copper-tin samples show much higher surface concentrations than copper-aluminum. This result might be expected on the basis of this model since the Cu-Sn and the

Fe-Al misfits are larger and bulk elastic properties are different from Cu-Al and consequently a higher strain energy and hence higher surface concentration for a given temperature might be expected.

An important point to be made from the results of these studies is that in performing adhesion and friction experiments, surface conditions may vary radically from bulk concentration, since most materials used are either alloys or have bulk contaminants such as carbon or sulfur. In addition surface chemistry may be radically affected by these surface conditions and surface reaction may not be at all what would be expected if bulk concentrations are assumed.

## B. Adhesion and Friction Experiments

I. Adhesion Experiments - Fig. 7 summarizes the results of adhesion experiments on a set of copper-aluminum alloys and a copper-tin alloy with a gold (111) single crystal. In the case of copper-aluminum it is evident that small percentages of aluminum in these alloys radically affects the adhesive properties as compared with pure copper; in fact, the bonding force rapidly approaches that observed with pure aluminum-gold.

For the copper-tin specimen (Fig. 8), a somewhat different experiment was performed. The adhesive behavior following sputtering and following heating was observed. As can be seen, following heating the adhesive bonding force is reduced.

This behavior can readily be explained by use of the results of the surface segregation experiments. As shown there, the solute is popping out onto the surface and presenting a substantially different surface to

the gold crystal. One would a priori expect that the affects on adhesion would only reflect bulk concentration if surface segregation did not occur. Large changes in surface properties with adsorption are well known. For example, the work function of tungsten (12) changes radically with cesium adsorption. At 0.7 monolayer the work function drops from 5 ev to 1.47 ev. At one monolayer it is 2.18 ev approximately the work function of pure cesium. Therefore it is not surprising that if indeed the solute atom were popping out onto the surface, large changes in adhesive behavior would be expected.

II. Friction Experiments - Friction experiments (7) showed that surface segregation has practical relevance. Buckley (7) performed friction experiments on a number of polycrystalline iron-aluminum alloys. The results on Fe-10 a/o aluminum upon which AES surface segregation experiments were performed are presented as typical examples of the results. Fig. 8 shows the variation of friction coefficient for a surface lubricated with hexadecane containing varying percentage of stearic acid. The dry friction coefficients (7) are much higher than for pure iron as would be expected from both AES results on iron-aluminum and the adhesive behavior. The lubricated friction behavior with stearic acid present also varied greatly from pure iron indicating that changes in surface chemistry occurred with the Fe-10 a/o Al alloy.

Therefore, even in the friction process where the surface layer could be worn away surface segregation can be occurring to replenish the worn layer and producing marked changes. As stated earlier lattice stress along with thermal effects could be sufficient to promote surface segregation.

### CONCLUDING OBSERVATIONS

This review indicates that several major conclusions relevant to friction and wear can be drawn.

Alteration in both adhesive and friction properties of alloys or materials containing contaminants may occur much in excess of what would be expected on the basis of bulk concentration. This effect has been seen with copper-aluminum, copper-tin, and iron-aluminum alloys. AES and LEED can be used to supplement experimental observation in practical friction studies and aid in the interpretation of results. AES and LEED have shown that conclusions based only on bulk composition of materials can lead to a misinterpretation of experimental results.

## REFERENCES

1. Lander, J. J., "Low-Energy Electron Diffraction and Surface Structural Chemistry," Progress in Solid State Chemistry, Vol. 2, H. Reiss, ed., Pergamon Press, 1965, pp. 26-116.
2. Palmberg, P. W. and Rhodin, T. N., "Auger Electron Spectroscopy of fcc Metal Surfaces," Journal of Applied Physics, Vol. 39, No. 5, Apr. 1968, pp. 2425-2432.
3. Musket, R. G. and Ferrante, J., "Auger Electron Spectroscopy Study of Oxygen Adsorption on W(110)," Journal of Vacuum Science and Technology, Vol. 7, No. 1, Jan./Feb. 1970, pp. 14-17.
4. Buckley, D. H., "Effect of Various Properties of FCC Metals on Their Adhesion as Studied with LEED," Journal of Adhesion, Vol. 1, Oct. 1969, pp. 264-281.
5. Ferrante, J. and Buckley, D. H., "Auger Electron Spectroscopy Study of Surface Segregation in Copper-Aluminum Alloys," TN D-6095, 1970, NASA, Cleveland, Ohio.
6. Ferrante, J.: An Auger Electron Spectroscopy and LEED Study of Equilibrium Surface Segregation in Copper-Aluminum Alloys, to be published in Acta Metallurgica.
7. Buckley, D. H., "Influence of Aluminum on Friction and Wear of Iron-Aluminum Alloys Dry and Lubricated," TN D-6359, 1971, NASA, Cleveland, Ohio.
8. McClean, D., Grain Boundaries in Metals, Clarendon Press, Oxford, 1957.

9. Langfried, N. and Wehner, G. K., "Sputtering Yields of Metals for  $\text{Ar}^+$  and  $\text{Ne}^+$  Ions with Energies from 50 to 600 ev," Journal of Applied Physics, Vol. 32, No. 3, Mar. 1961, pp. 365-369.
10. Wehner, G., "Sputtering," International Science and Technology, No. 81, Sept. 1968, pp. 32-39.
11. Germer, L. H. and May, J. W., "Diffraction Study of Oxygen Adsorption on a (110) Tungsten Face," Surface Science, Vol. 4, 1966, pp. 452-470.
12. Swanson, L. W. and Strayer, R. W., "Field-Electron-Microscopy Studies of Cesium Layers on Various Refractory Metals: Work Function Change," Journal of Chemical Physics, Vol. 48, No. 6, Mar. 15, 1968, pp. 2421-2442.

Table I. - Maximum Coverage of Minor Constituent on Alloy Surfaces

Alloy	Ratio of surface concentration to bulk concentration	Atomic size from lattice nearest neighbor distance
Cu-1 a/o Al	6.5	Cu - 2.556 Angstrom - f. c. c.
Cu-5 a/o Al	4.5	Al - 2.862 - f. c. c.
Cu-10 a/o Al	3.1	Sn - 3.022 - Tetragonal
Cu-1 a/o Sn	15.0±2	Fe - 2.481 - b. c. c.
Fe-10 a/o Al	8.0	

Note: Atomic size gives a rough measure of the amount that the alloy atom strains the parent lattice.

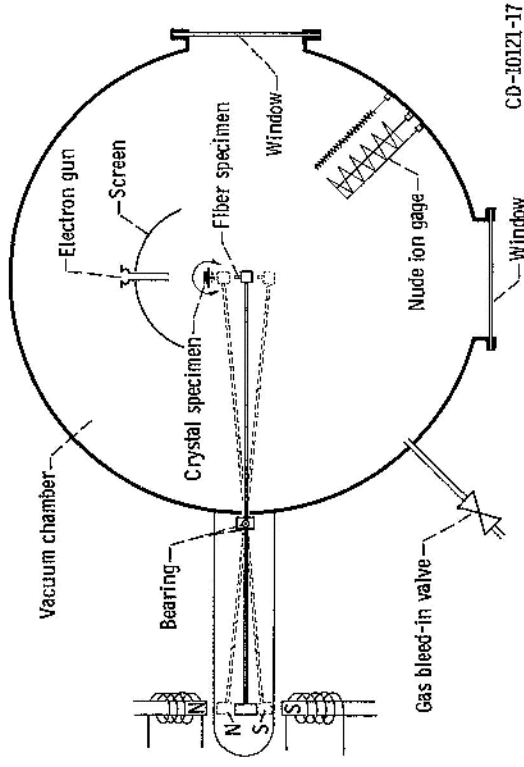

CD-10121-17

Figure 1 - Low energy electron diffraction LEED adhesion apparatus.

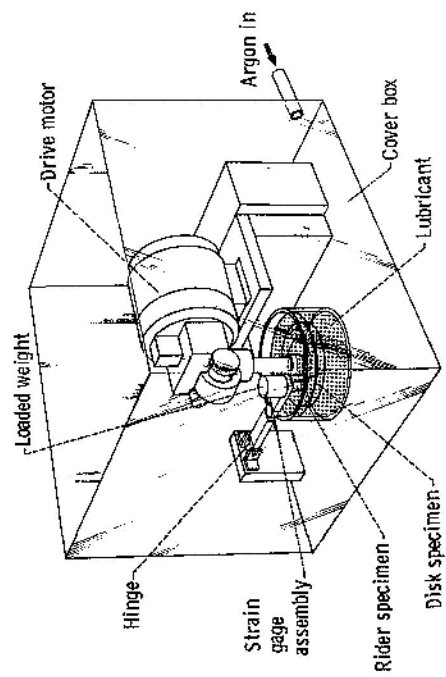

CD-10695-15

Figure 2 - Sketch of friction apparatus.

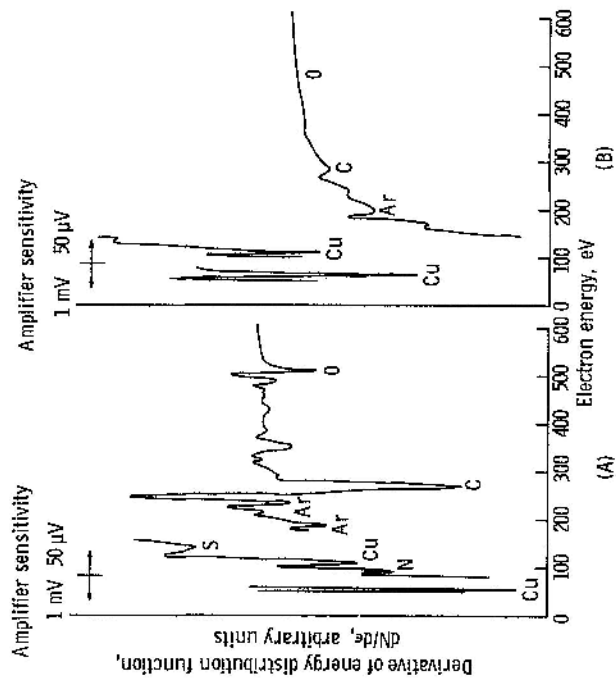
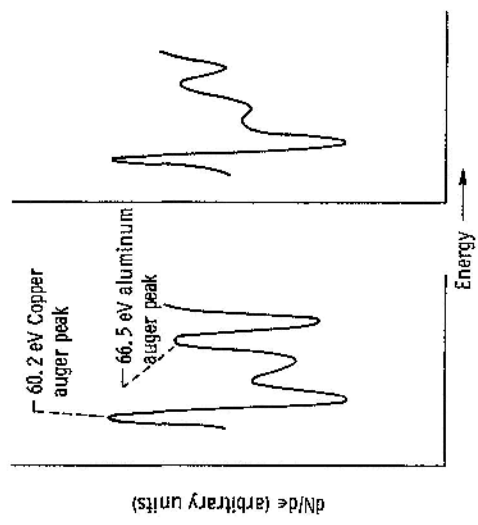

Figure 3 - Derivative of secondary electron energy distribution function showing effects of sputter cleaning.



(a) Crystal heated for 3 - 5 hours at 600 C following sputtering for 17 hours.  
 (b) Crystal sputtered for 500 seconds at 400 eV beam energy and  $5 \times 10^{-7}$  amp/cm<sup>2</sup> current density.

Figure 4 - Effects of heating then sputtering on copper and aluminum Auger peaks.



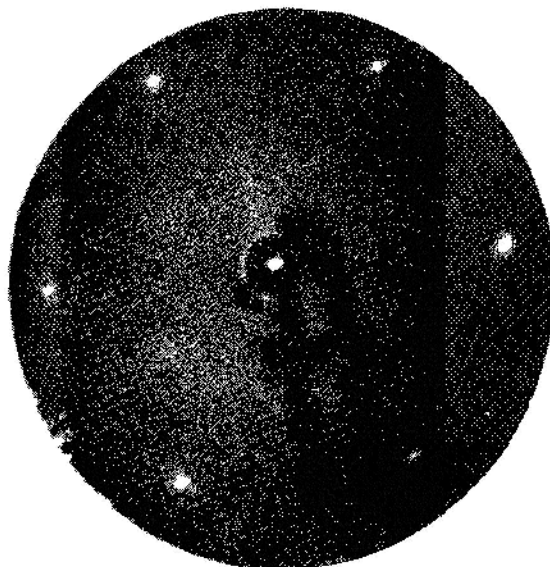

(a) Copper-5 a/o aluminum, beam energy = 100 eV.

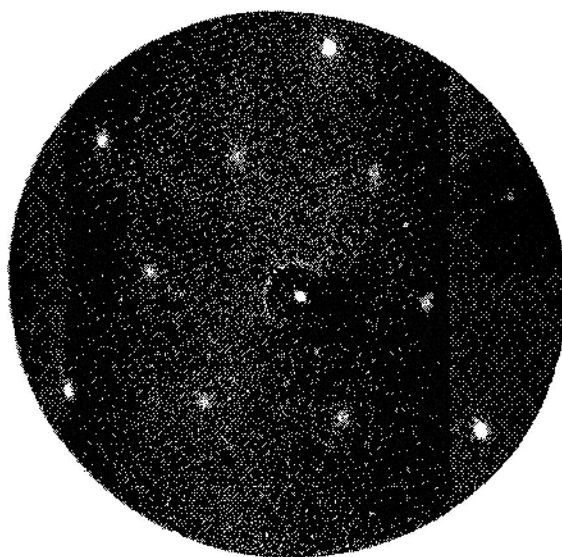

C-70-2672

(b) Copper-10 a/o aluminum, beam energy = 114 eV.

Figure 5. - LEED patterns and interpretations for copper-aluminum alloys.

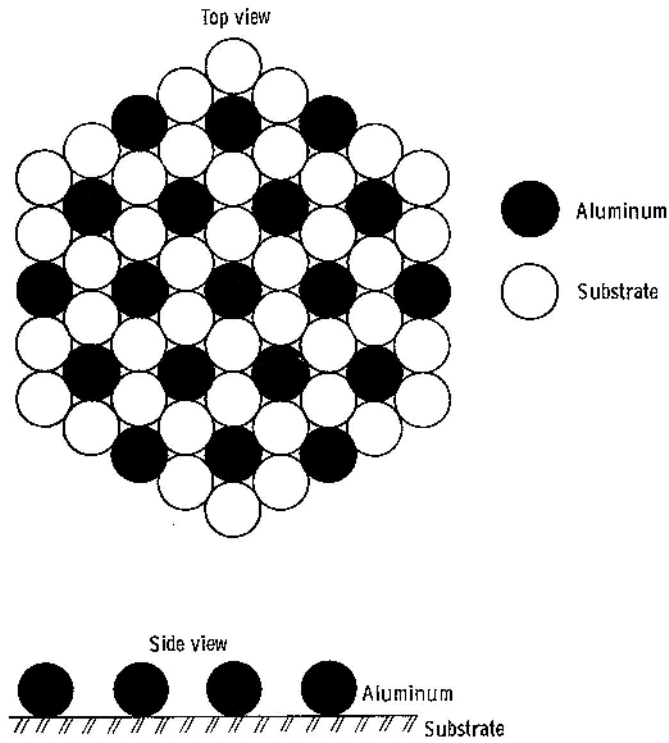

(c) Possible direct lattice structure observed for LEED pattern  $R30^\circ$  ( $2 \times 2$ ) structure showing  $1/3$  monolayer coverage.

Figure 5. - Concluded.

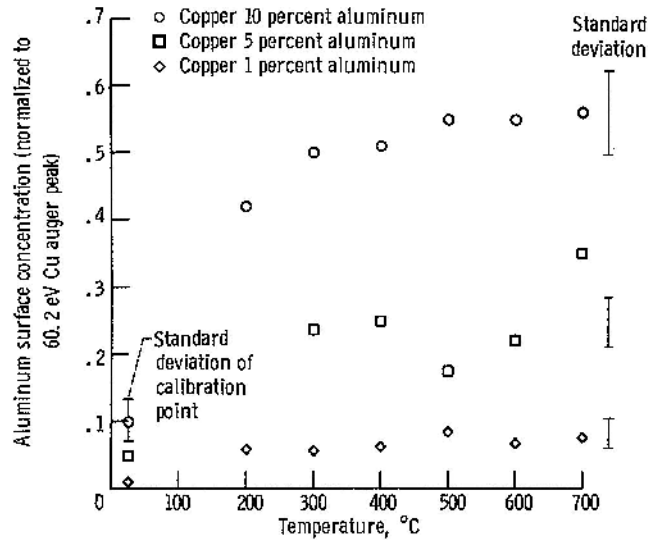

Figure 6. - Increase of aluminum surface concentration for Cu-1, 5, and 10 a/o aluminum alloys. For each point the crystal was sputtered, heated for 30 minutes, then allowed to cool to room temperature.

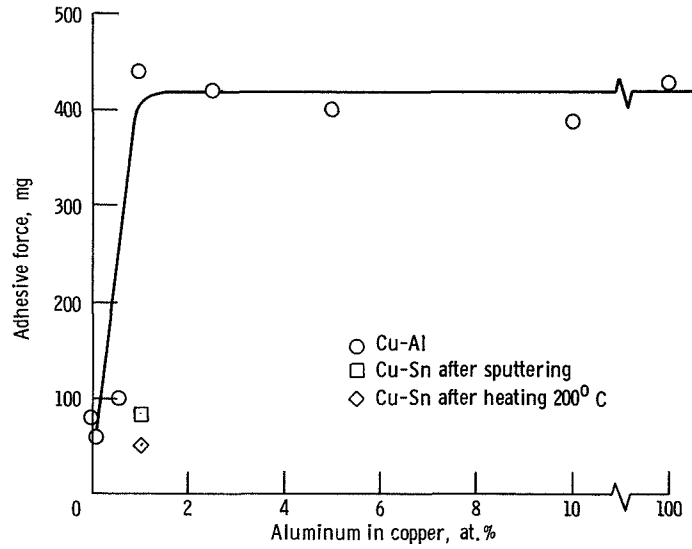

Figure 7. - Adhesive force of (111) gold to (111) surface of copper and copper alloys as a function of bulk concentration.

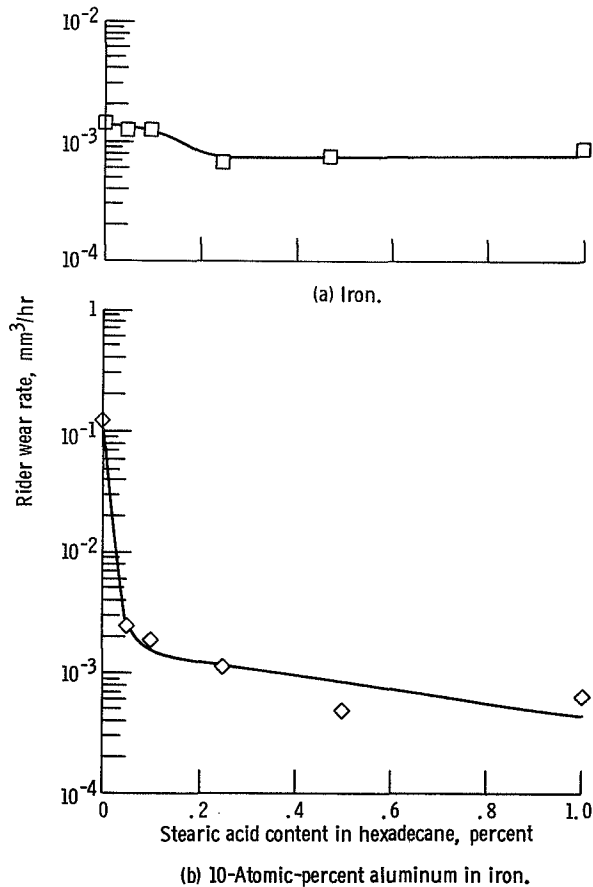

Figure 8. - Effect of stearic acid concentration in hexadecane for iron and iron 10 a/o aluminum, sliding velocity 3.8 cm/sec, load 250 g.