



International Journal of  
**Medicinal Chemistry & Analysis**

[www.ijmca.com](http://www.ijmca.com)

e ISSN 2249 - 7587

Print ISSN 2249 - 7595

## A REVIEW ON BASIC CHROMATOGRAPHIC TECHNIQUES

**\*M. Surendra, T. Yugandharudu, T. Viswasanthi**

Nirmala College of Pharmacy, Buddayapalle (P), Kadapa - 516002, Andhra Pradesh, India.

### ABSTRACT

This article presents a review of basic chromatographic techniques applied to the determination of various pharmaceuticals is discussed. It describes about various Chromatographic techniques and its usage. Also it briefly describes about the instruments, methods used in it. Chromatographic separations can be carried out using a variety of supports, including immobilized silica on glass plates (thin layer chromatography), volatile gases (gas chromatography), paper (paper chromatography), and liquids which may incorporate hydrophilic, insoluble molecules (liquid chromatography).

**Keywords:** Chromatography, HPLC, TLC, GC, Method development, Validation.

### INTRODUCTION

Chromatography is the science which studies the separation of molecules based on differences in their structure and/or composition. In general, chromatography involves moving a preparation of the materials to be separated - the "test preparation" - over a stationary support. The molecules in the test preparation will have different interactions with the stationary support leading to separation of similar molecules. Test molecules which display tighter interactions with the support will tend to move more slowly through the support than those molecules with weaker interactions. In this way, different types of molecules can be separated from each other as they move over the support material [1].

Chromatographic separations can be carried out using a variety of supports, including immobilized silica on glass plates (thin layer chromatography), volatile gases (gas chromatography), paper (paper chromatography), and liquids which may incorporate hydrophilic, insoluble molecules (liquid chromatography).

### Chromatography and Biotechnology

This discussion of chromatography will focus on the separation of proteins into relatively homogeneous groups because proteins are often the target molecules

which must be purified for use as "biopharmaceuticals" or medicines. It is important to remember, however, that chromatography can also be applied to the separation of other important molecules including nucleic acids, carbohydrates, fats, vitamins, and more.

One of the important goals of biotechnology is the production of the therapeutic molecules known as "biopharmaceuticals," or medicines [2]. There are a number of steps that researchers go through to reach this goal:

- identification of a "target protein" which may have therapeutic value
- identification of the "target gene" -- the gene responsible for encoding the target protein
- isolation of the target gene
- insertion of the target gene into a host cell (such as E. coli) which will both grow well, and continue to produce the protein product encoded for by the target gene
- separation of the target protein from the many other host cell proteins
- large scale production of the target protein under controlled manufacturing conditions
- large scale testing for efficacy as a medicine marketing of a new medicine

- Many different disciplines, including microbiology, molecular biology, chemistry, and others, are required to complete the steps listed above to bring a protein from the "scientifically interesting" state to that of a full-fledged drug to be used in treating a specific disease. This discussion will focus on the work and tools of the chromatographer.

Chromatographers use many different types of chromatographic techniques in biotechnology as they bring a molecule from the initial identification stage to the stage of a becoming a marketed product. The most commonly used of these techniques is liquid chromatography, which is used to separate the target molecule from undesired contaminants (usually host-related), as well as to analyze the final product for the requisite purity established with governmental regulatory groups (such as the FDA) [3].

#### **Some examples of liquid chromatographic techniques are described below:**

##### **Ion-Exchange Chromatography**

Proteins are made up of twenty common amino acids. Some of these amino acids possess side groups ("R" groups) which are either positively or negatively charged. A comparison of the overall number of positive and negative charges will give a clue as to the nature of the protein. If the protein has more positive charges than negative charges, it is said to be a basic protein. If the negative charges are greater than the positive charges, the protein is acidic. When the protein contains a predominance of ionic charges, it can be bound to a support that carries the opposite charge. A basic protein, which is positively charged, will bind to a support which is negatively charged. An acidic protein, which is negatively charged, will bind to a positive support. The use of ion-exchange chromatography, then, allows molecules to be separated based upon their charge. Families of molecules (acidic, basic and neutrals) can be easily separated by this technique. This is perhaps the most frequently used chromatographic technique used for protein purification [4].

##### **Hydrophobic Interaction Chromatography ("HIC")**

Not all of the common amino acids found in proteins are charged molecules. There are some amino acids that contain hydrocarbon side-chains which are not charged and therefore cannot be purified by the same principles involved in ion-exchange chromatography. These hydrophobic ("water-hating") amino acids are usually buried away in the inside of the protein as it folds into its biologically active conformation. However, there is usually some distribution of these hydrophobic residues on the surface of the molecule. Since most of the hydrophobic groups are not on the surface, the use of HIC allows a much greater selectivity than is observed for ion-exchange chromatography. These hydrophobic amino

acids can bind on a support which contains immobilized hydrophobic groups [5]. It should be noted that these HIC supports work by a "clustering" effect; no covalent or ionic bonds are formed or shared when these molecules associate.

##### **Gel-Filtration Chromatography**

This technique separates proteins based on size and shape. The supports for gel-filtration chromatography are beads which contain holes, called "pores," of given sizes. Larger molecules, which can't penetrate the pores, move around the beads and migrate through the spaces which separate the beads faster than the smaller molecules, which may penetrate the pores. This is the only chromatographic technique which does not involve binding of the protein to a support.

##### **Affinity Chromatography**

This is the most powerful technique available to the chromatographer. It is the only technique which can potentially allow a one-step purification of the target molecule. In order to work, a specific ligand (a molecule which recognizes the target protein) must be immobilized on a support in such a way that allows it to bind to the target molecule. A classic example of this would be the use of an immobilized protein to capture its receptor (the reverse would also work). This technique has the potential to be used for the purification of any protein, provided that a specific ligand is available. Ligand availability and the cost of the specialized media are usually prohibitive at large-scale [6].

##### **Types of Chromatography**

###### **Adsorption Chromatography**

Adsorption chromatography is probably one of the oldest types of chromatography around. It utilizes a mobile liquid or gaseous phase that is adsorbed onto the surface of a stationary solid phase. The equilibration between the mobile and stationary phase accounts for the separation of different solutes (Fig 1).

###### **Partition Chromatography**

This form of chromatography is based on a thin film formed on the surface of a solid support by a liquid stationary phase. Solute equilibrates between the mobile phase and the stationary liquid (Fig 2).

###### **Ion Exchange Chromatography**

In this type of chromatography, the use of a resin (the stationary solid phase) is used to covalently attach anions or cations onto it. Solute ions of the opposite charge in the mobile liquid phase are attracted to the resin by electrostatic forces (Fig 3).

###### **Molecular Exclusion Chromatography**

Also known as gel permeation or gel filtration, this type of chromatography lacks an attractive interaction between the stationary phase and solute. The liquid or gaseous phase passes through a porous gel which separates the molecules according to its size. The pores are normally small and exclude the larger solute molecules, but allow smaller molecules to enter the gel, causing them to flow through a larger volume. This causes the larger molecules to pass through the column at a faster rate than the smaller ones (Fig 4).

### **Affinity Chromatography**

This is the most selective type of chromatography employed. It utilizes the specific interaction between one kind of solute molecule and a second molecule that is immobilized on a stationary phase. For example, the immobilized molecule may be an antibody to some specific protein. When solute containing a mixture of proteins is passed by this molecule, only the specific protein is reacted to this antibody, binding it to the stationary phase. This protein is later extracted by changing the ionic strength or pH (Fig 5).

## **PAPER CHROMATOGRAPHY**

### **Advantages of Paper Chromatography**

Why use paper chromatography? In a nutshell, this analytical method is quick to perform and easy to master. With a correctly chosen mobile phase (chromatographic solvent), an analyst can rapidly determine the number of constituents of a mixture sample. Sometimes, paper chromatography even allows one to positively identify these constituents. Another advantage of this method is that it requires a relatively small sample and is very inexpensive - a big plus in today's cost-conscious world.

### **Disadvantages of Paper Chromatography**

Like all analytical methods, paper chromatography has its limitations. Some mixtures are very difficult to separate by paper chromatography; and any species that is not coloured is difficult to observe on the chromatogram. Also, paper chromatography is solely an analytical method, not a preparative one. Because the sample size is so small, it is difficult to perform further analysis after the sample's contents have been chromatographically separated. This is in contrast to methods such as column chromatography, which are frequently used to preparatively separate larger amounts of mixtures. Lastly, paper chromatography can only be used in qualitative analysis [7]. It is not possible to extract meaningful information about the quantitative content of a mixture from a paper chromatogram.

### **The Mobile and Stationary Phase in Paper Chromatography**

Like all chromatographic methods, paper chromatography is based upon differences in physical properties among the constituents of the mixture that is being analyzed. These differences play themselves out as the mixture is allowed to interact with the two chromatographic phases: the mobile phase and the stationary phase.

The stationary phase in paper chromatography is made up of a combination of the paper's cellulose fibers and associated water molecules. The cellulose fibers are highly polar chains of covalently joined sugar molecules. Their many OH groups allow for extensive hydrogen bonding to free water molecules. Thus, the paper chromatography stationary phase is a very polar matrix of cellulose and bound water [8].

The segment in brackets repeats many times in the chain. Note the many oxygen atoms and hydroxyl groups, which are capable of hydrogen bonding.

The mobile phase in paper chromatography is simply whichever solvent is used to elute, or develop the chromatographic plate. In most cases, this solvent is water, although sometimes various alcohols are used. The solvent travels through the fibers by capillary action, thereby carrying the sample with it.

The separation in paper chromatography is achieved because the components of the mixture being separated are different from each other in polarity and hydrogen bonding ability. The more polar/better hydrogen bonding components of the mixture adsorb more strongly to the cellulose/water stationary phase, and are thus carried more slowly through the stationary phase. By contrast, the less polar components or those less capable of hydrogen bonding are less strongly adsorbed onto the cellulose/water matrix and travel faster through the stationary phase. Even a small difference in polarity or hydrogen bonding ability is sufficient to produce an observable separation [9].

### **Proper Experimental Technique**

Before starting any paper chromatography experiment, be sure that your hands are clean and dry. Contamination from your hands, including the natural oils on your skin, can interfere with the chromatographic process. Try to minimize contact with the stationary phase, and try to only hold it by the edges. Obtain a long strip of filter paper, and draw a line in pencil across it, widthwise, 1 cm away from one of the ends. To spot your sample onto the filter paper (the chromatographic plate or stationary phase), dip a toothpick or a capillary pipet into a concentrated beverage sample and then lightly touch it to the middle of the pencil line that you have drawn. If your

beverage is too dilute, concentrate it by boiling in a hot water bath. You may need to repeat this process several times before spotting is complete. The spot should be brightly coloured but small in diameter.

To set up the chromatographic chamber, take a clean beaker and lay a wooden stick across the top. Carefully hang the paper over the wooden stick by creasing it appropriately. The edge with the spot should be hanging about a half centimeter above the bottom of the beaker. Mark this level approximately on the outside of the beaker. Once you are satisfied with the set-up, remove the filter paper from the beaker. Pour your mobile phase (salt water) into the beaker so that it is just barely over your mark on the beaker. It is very important that the water level is lower than your spot.

To start the development, gently lower the stick with the hanging filter paper until the bottom end is suspended in the mobile phase. Try to insert the paper at a 90 degree angle to the water – this will make the solvent front and your spots travel in a straight line. You will see something like the following:

Once the wooden stick is seated, cover the beaker with a watch glass to maintain solvent-vapour equilibrium. Open the beaker and remove the watch glass when you observe a clear separation of spots, or are satisfied that your sample is not a mixture of components. Remove the filter paper from the mobile phase and allow it to hang dry.

### Interpreting Results

For the purposes of your food dye experiment, your paper chromatogram will tell you whether your beverage sample contains more than one food dye, the colour of the component dyes, and their relative polarities (as observed from the distance that the spots have traveled up the chromatogram). Paper chromatography will let you make preliminary colour identifications qualitatively. You can confirm the precise identity of your food dyes by matching absorbance spectra from colorimetry experiments.

Most paper chromatography experiments actually do allow you to attempt to identify the components of a mixture, with reasonably accurate results. You will not do this in your experiment because of time constraints, and because of a complication caused by the high sugar content of your beverages.

In most other paper chromatography experiments, however, such identifications are possible. These are based on two properties of a substance making up a spot. One is its colour - something that you *will* be able to observe in your food dye experiment. The other property is called the retention factor, or  $R_f$ . You will not be measuring this property in your experiment this year. The content below this point is optional reading for your

enrichment. Labs in organic courses do require you to master this concept.

The retention factor is a number between 0 and 1, which is characteristic of every substance, and, very importantly, of both the mobile phase and the stationary phase. For example, the  $R_f$  of erythrosine in a paper/salt water system will not necessarily be the same as that of erythrosine in a paper/ethyl alcohol system. Thus, in order to compare  $R_f$ s from different experiments, it is imperative that the same mobile phase and stationary phase be used in each.

The retention factor is calculated as follows. A paper chromatography experiment is run until the solvent front (the top edge of the mobile phase traveling through the stationary phase) is approximately 1-1.5 cm from the top edge of the paper. At that point, the development is rapidly halted and the final position of the solvent front is marked. The paper is allowed to dry, and a number of distance measurements are taken. For each spot in the developed chromatogram, its distance from the starting line is measured. The distance that the solvent front has moved beyond the starting line is also recorded. These measurements are shown in the diagram below.

Here, X is the distance traveled by the blue spot from the starting line, Y is the distance traveled by the red spot from the starting line, and Z is the distance traveled by the solvent front beyond the starting line.

The  $R_f$  of the blue spot is  $X / Z$ , while the  $R_f$  of the red spot is  $Y / Z$ . The  $R_f$  is therefore a unitless ratio of distances measured from the chromatographic plate.

While the  $R_f$  does depend on the chromatographic system, its key useful feature is that it is independent of the dimensions of the chromatographic plate. Only the ratio of the distances matters in determining the retention factor, and not their absolute magnitudes. Therefore,  $R_f$  measurements obtained from chromatographic plates of the same size can be reliably compared - the only necessary condition is that the material making up the plates and the solvent used to develop the plates must be the same.

With this understanding of the retention factor, we can now turn to its application in identifying substances. For example, you are trying to identify the colouring agents present in a purple solution. You analyze a concentrated sample of the solution by paper chromatography and find that the purple spot separates into a red and blue spot, with respective retention factors of 0.82 and 0.40.

You have three red and two blue dye samples that you believe may be present in your unknown sample. Running paper chromatography on your red dye samples, on separate plates or in parallel on one plate, yields  $R_f$

values of 0.25, 0.42, and 0.83 for the red samples. By matching the colour of the samples and the  $R_f$  values, you can be quite confident that the red sample with the retention factor of 0.83 is the one that is present in your unknown. Performing an analogous set of experiments on the suspected blue constituents, you obtain retention factors of 0.60 and 0.45 for the blue spots. By a similar process of reasoning, the dye with the  $R_f$  value of 0.45 is very likely to be the blue constituent of your unknown mixture. As you may have noticed,  $R_f$  values, like other measurements, are susceptible to experimental error. The reliability of the identification depends upon how precisely the retention factors match.

Using the principles of chemistry that underlie chromatography, explain why  $R_f$  values obtained from one chromatographic system (i.e. paper/salt water) are not compatible with those obtained from a different system (i.e. paper/isopropyl alcohol).

For a different perspective, the process that has just been described is diagrammed below.

### THIN LAYER CHROMATOGRAPHY

Chromatographic separations take advantage of the fact that different substances are partitioned differently between two phases, a mobile phase and a stationary phase. You have already had some experience with gas chromatography where the mobile phase is an inert gas, usually helium, and the stationary phase is a high boiling liquid coating adsorbed on the surface of a granular solid in a column. In thin layer chromatography, or TLC, the mobile phase is a liquid and the stationary phase is a solid adsorbent.

The principle of separation is adsorption. One or more compounds are spotted on a thin layer of adsorbent coated on a chromatographic plate. The mobile phase solvent flows through because of capillary action. The component with more affinity towards the stationary phase travels slower. The component with lesser affinity towards the stationary phase travels faster.

#### Theory of Thin Layer Chromatography

In thin layer chromatography, a solid phase, the adsorbent, is coated onto a solid support as a thin layer (about 0.25 mm thick). In many cases, a small amount of a binder such as plaster of Paris is mixed with the adsorbent to facilitate the coating. Many different solid supports are employed, including thin sheets of glass, plastic, and aluminum. The mixture (A plus B) to be separated is dissolved in a solvent and the resulting solution is spotted onto the thin layer plate near the bottom. A solvent, or mixture of solvents, called the eluant, is allowed to flow up the plate by capillary action. At all times, the solid will adsorb a certain fraction of each component of the mixture and the remainder will be in solution. Any one molecule will spend part of the time sitting still on the adsorbent

with the remainder moving up the plate with the solvent. A substance that is strongly adsorbed (say, A) will have a greater fraction of its molecules adsorbed at any one time, and thus any one molecule of A will spend more time sitting still and less time moving. In contrast, a weakly adsorbed substance (B) will have a smaller fraction of its molecules adsorbed at any one time, and hence any one molecule of B will spend less time sitting and more time moving. Thus, the more weakly a substance is adsorbed, the farther up the plate it will move. The more strongly a substance is adsorbed, the closer it will stay near the origin [10].

Several factors determine the efficiency of a chromatographic separation. The adsorbent should show a maximum of selectivity toward the substances being separated so that the differences in rate of elution will be large. For the separation of any given mixture, some adsorbents may be too strongly adsorbing or too weakly adsorbing. Table 1 lists a number of adsorbents in order of adsorptive power.

The eluting solvent should also show a maximum of selectivity in its ability to dissolve or desorb the substances being separated. The fact that one substance is relatively soluble in a solvent can result in its being eluted faster than another substance. However, a more important property of the solvent is its ability to be itself adsorbed on the adsorbent. If the solvent is more strongly adsorbed than the substances being separated, it can take their place on the adsorbent and all the substances will flow together. If the solvent is less strongly adsorbed than any of the components of the mixture, its contribution to different rates of elution will be only through its difference in solvent power toward them. If, however, it is more, strongly adsorbed than some components of the mixture and less strongly than others, it will greatly speed the elution of those substances that it can replace on the adsorbent, without speeding the elution of the others.

Table 2 lists a number of common solvents in approximate order of increasing adsorbability, and hence in order of increasing eluting power. The order is only approximate since it depends upon the nature of the adsorbent. Mixtures of solvents can be used, and, since increasing eluting power results mostly from preferential adsorption of the solvent, addition of only a little (0.5-2%, by volume) of a more strongly adsorbed solvent will result in a large increase in the eluting power. Because water is among the most strongly adsorbed solvents, the presence of a little water in a solvent can greatly increase its eluting power. For this reason, solvents to be used in chromatography should be quite dry [11]. The particular combination of adsorbent and eluting solvent that will result in the acceptable separation of a particular mixture can be determined only by trial.

If the substances in the mixture differ greatly in adsorbability, it will be much easier to separate them. Often, when this is so, a succession of solvents of increasing eluting power is used. One substance may be eluted easily while the other stays at the top of the column, and then the other can be eluted with a solvent of greater eluting power. Table 3 indicates an approximate order of adsorbability by functional group.

### Technique of Thin-layer Chromatography

The sample is applied to the layer of adsorbent, near one edge, as a small spot of a solution. After the solvent has evaporated, the adsorbent-coated sheet is propped more or less vertically in a closed container, with the edge to which the spot was applied down. The spot on the thin layer plate must be positioned above the level of the solvent in the container. If it is below the level of the solvent, the spot will be washed off the plate into the developing solvent. The solvent, which is in the bottom of the container, creeps up the layer of adsorbent, passes over the spot, and, as it continues up, effects a separation of the materials in the spot ("develops" the chromatogram). When the solvent front has nearly reached nearly the top of the adsorbent, the thin layer plate is removed from the container (Fig 10).

Since the amount of adsorbent involved is relatively small, and the ratio of adsorbent to sample must be high, the amount of sample must be very small, usually much less than a milligram. For this reason, thin-layer chromatography (TLC) is usually used as an analytical technique rather than a preparative method. With thicker layers (about 2 mm) and large plates with a number of spots or a stripe of sample, it can be used as a preparative method. The separated substances are recovered by scraping the adsorbent off the plate (or cutting out the spots if the supporting material can be cut) and extracting the substance from the adsorbent.

Because the distance traveled by a substance relative to the distance traveled by the solvent front depends upon the molecular structure of the substance, TLC can be used to identify substances as well as to separate them. The relationship between the distance traveled by the solvent [12] front and the substance is usually expressed as the  $R_f$  value:

$$R_f \text{ Value} = \frac{\text{distance traveled by substance}}{\text{distance traveled by solvent front}}$$

The  $R_f$  values are strongly dependent upon the nature of the adsorbent and solvent. Therefore, experimental  $R_f$  values and literature values do not often agree very well. In order to determine whether an unknown substance is the same as a substance of known structure, it is necessary to run the two substances side by side in the same chromatogram, preferably at the same concentration.

### Detecting Agents

Two Types:

- a. Non Specific Methods
- b. Specific Methods

#### Non Specific Methods

Where the number of spots can be detected but not exact nature or type compound

Example:

- Iodine Chamber Method
- Sulphuric Acid spray reagent
- UV chamber for fluorescent compounds
- Using fluorescent stationary phase.

#### Specific Methods

Specific spray reagents or detecting agents or visualizing agents are used to find out the nature of compounds or for identification purpose.

Example:

- Ferric chloride – for Phenolic compounds and tannins
- Ninhydrin in acetone – for amino acids
- Dragendorff's reagent – for alkaloids
- 3,5 – Dinitro benzoic acid – for cardiac glycosides
- 2,4 – Dinitrophenyl hydrazine – for aldehydes and ketones.

### Application of the Sample

The sample to be separated is generally applied as a small spot (1 to 2 mm diameters) of solution about 1 cm from the end of the plate opposite the handle. The addition may be made with a micropipet prepared by heating and drawing out a melting point capillary. As small a sample as possible should be used, since this will minimize tailing and overlap of spots; the lower limit is the ability to visualize the spots in the developed chromatogram. If the sample solution is very dilute, make several small applications in the same place, allowing the solvent to evaporate between additions [13]. Do not disturb the adsorbent when you make the spots, since this will result in an uneven flow of the solvent. The starting position can be indicated by making a small mark near the edge of the plate.

### Development of thin layer plates

The chamber used for development of the chromatogram (Figure 11) can be as simple as a beaker covered with a watch glass, or a cork-stoppered bottle. The developing solvent (an acceptable solvent or mixture of solvents must be determined by trial) is poured into the container to a depth of a few millimeters. The spotted plate is then placed in the container, spotted end down; the solvent level must be below the spots (see figure below). The solvent will then slowly rise in the adsorbent by capillary action [14].

In order to get reproducible results, the atmosphere in the development chamber must be saturated with the solvent. This can be accomplished by sloshing the solvent around in the container before any plates have been added. The atmosphere in the chamber is then kept saturated by keeping the container closed all the time except for the brief moment during which a plate is added or removed.

### Visualization

When the solvent front has moved to within about 1 cm of the top end of the adsorbent (after 15 to 45 minutes), the plate should be removed from the developing chamber, the position of the solvent front marked, and the solvent allowed to evaporate. If the components of the sample are colored, they can be observed directly. If not, they can sometimes be visualized by shining ultraviolet light on the plate (Fig 12) or by allowing the plate to stand for a few minutes in a closed container in which the atmosphere is saturated with iodine vapor. Sometimes the spots can be visualized by spraying the plate with a reagent that will react with one or more of the components of the sample [15].

### General preparation of materials

- The thin layer chromatography plates are commercial pre-prepared ones with a silica gel layer on a glass, plastic, or aluminum backing. Use the wide plates for spotting several compounds on the same plate. This allows for more precise comparison of the behavior of the compounds.
- The samples are spotted on the thin layer plates using fine capillaries drawn from melting point capillaries. You will need to draw several spotters. Your teaching assistant will demonstrate the technique (mystical art?) of drawing capillaries.
- Samples for spotting are prepared by dissolving approximately 0.1 g (the amount on the tip of a spatula) of the compound in less than 0.5 mL of a solvent (ethyl acetate, dichloromethane, or ether work well).
- When spotting samples on the TLC plates, it is a good idea to check if enough samples have been spotted on the plate. Allow the solvent to evaporate and then place the plate under a short wavelength ultraviolet lamp. A purple spot on a background of green should be clearly visible. If the spot is faint or no spot is apparent, more samples will have to be applied to the plate.
- The chromatograms are developed in a 150-mL beaker or jar containing the developing solvent. The beaker is covered with a small watch glass. A wick made from a folded strip of filter paper is used to keep the atmosphere in the beaker saturated with solvent vapor.
- When the plates are removed from the developing solvent, the position of the solvent front is marked, and the solvent is allowed to evaporate. The positions of the spots

are determined by placing the plates under a short wavelength ultraviolet lamp. The silica gel is mixed with an inorganic phosphor which fluoresces green in the UV light. Where there are compounds on the plates, the fluorescence is quenched and a dark purple spot appears.

## GAS CHROMATOGRAPHY

### Introduction

The key parts of a gas chromatograph include: a source of gas as the mobile phase, an inlet to deliver sample to a column, the column where separations occur, an oven as a thermostat for the column, a detector to register the presence of a chemical in the column effluent, and a data system to record and display the chromatogram. In addition, some facility is needed so that temperatures of various components can be accurately known and controlled. These parts of a gas chromatograph have been unchanged in function or purpose for over the last 40 years although technology has been ever improving in design, materials, and methodology. In particular, analog electronics for control of temperature zones and data acquisition were replaced with digital electronics and interfaced with computers in the 1970s and 1980s. The arrangement of these components is shown in a block diagram in Figure 1 and this arrangement is common to virtually all gas chromatographs regardless of age, model or manufacturer. A modern gas chromatograph is shown in Figure 2. In the discussion below, the general function of each component is provided with comments on the status of the technology. Most descriptions of GC will include a cursory description of instrumentation; few will provide a detailed treatment of the instrumentation or technical details. Some of the best discussions of hardware can be found in publications released by instrument manufacturers. Unfortunately, these may not be found routinely in libraries but the reward for efforts to obtain them is found in the useful details for optimizing an analysis or practical help for maintaining the instrument. The column may arguably be considered the key component of a gas chromatograph and accordingly has been treated separately under another heading. However, the total variance of a separation ( $s_T$ ) will conform to principles of error propagation and be a sum of variances from the injector ( $s_I$ ), column ( $s_C$ ), detector ( $s_D$ ), and data system ( $s_{DS}$ ), i.e.  $s_T^2 = s_I^2 + s_C^2 + s_D^2 + s_{DS}^2$ . Thus, each of these components contributes to the overall efficiency of a GC separation and merits individual attention [16].

### Carrier Gas

The carrier gas or mobile phase in GC is an essential, but limiting, facet in separations. Carrier gas is the means to move constituents of a sample through the column and yet the choice of possible gases is restricted. Moreover, the carrier gas has properties that sometimes can complicate an analysis. Unlike liquid chromatography (where a wide selection of mobile phase compositions

may be possible), very little can be gained in separations through altering the mobile phase composition to influence the partition coefficient ( $k$ ) or separation factor ( $\alpha$ ) in GC.

### Selection of Gases

The choice of a practical carrier gas is simple: nitrogen or helium. Air may be used as a carrier gas under certain conditions with portable or on-site chromatographs but this is uncommon with laboratory-scale instruments. The choice of nitrogen or helium is made, in part, on the principles of separation and, in part, on economics:  $\approx$  \$20 for a nitrogen cylinder versus  $\approx$  \$50 for a helium cylinder. However, the selection is more complex than the prices of gas cylinders alone. Column efficiency in GC contains a term for contributions to longitudinal broadening in the carrier gas and this is given by the  $D_g$  term in the van Deemter equation.<sup>3/</sup> This term is proportional to the square root of molar mass for the carrier gas, and nitrogen or argon would be preferred over helium based on  $D_g$  only. This effect can be seen in Figure 3, where nitrogen provides better performance than helium and has the lower contribution to plate height. However, the shape of the curve for height equivalent to a theoretical plate (HETP) versus flow rate (as linear velocity) for helium shows a reasonably good efficiency at high flow rates (HETP is equal to  $L/N$ , where  $L$  is the column length and  $N$  is the number of theoretical plates in a column.) In contrast, the van Deemter curve for nitrogen is comparatively narrow. Consequently, a GC separation using nitrogen at 10  $\text{cm}^1$  can be accomplished with comparable separating efficiency using helium at 50–60  $\text{cm}^1$ . The practical consequence of this is that costs for using helium, on a per sample basis, might be lower than those for nitrogen when the speed of analysis is factored into the calculations.

### Control of Flow

One difficulty in GC is the compressibility of the carrier gas and subsequent influence on separating performance. This was recognized in the first paper on GC where correction factors for gas flow rates were described. The implications for isothermal methods are significant but will be critical with temperature programmed GC when column temperatures may span 200 °C or more. When temperature is increased for a column with constant pressure on the inlet, the average flow rate in the column will decrease owing to increased viscosity of the gas/mobile phase in a proportional but nonlinear manner. Under such conditions, flow rates may slow at high temperature and both separation speed and efficiency may suffer. Flow may be kept constant through mass flow meters that have inlet and outlet orifices, adjustable based upon pressure differences. Constant flow can be delivered across a range of pressure drops that may arise due to changes in temperature but cannot compensate for changes in barometric pressure. An advance in instrumentation

during the past decade has been the commercialization of flow programming so that flows may be made highly reproducible [17].

### Gas Sources and Purity

A common gas source for nitrogen or helium is the pressurized cylinder or bottled gas supply, readily supplied as a steel tank with a two-stage pressure regulator. This is still a common gas source though gas generators for nitrogen (air and hydrogen too) can be commercially competitive with bottled gas and have advantages in safety. Regardless of the gas source, special attention must be given to the purity of tubing used to connect the source and the gas chromatograph and to impurities in the gas supply. Most columns do not tolerate moisture and oxygen well when operated at temperatures over 100 °C. Best results for column longevity and chromatographic reproducibility occur when the carrier gas is cleaned over molecular sieve beds (to reduce moisture). In addition, specialized traps can be purchased to reduce or remove hydrocarbons and oxygen in the carrier gas.

### Sample Inlets

The chromatographic process begins when sample is introduced into the column, ideally without disrupting flows in the column. The chromatographic results will be reproducible inasmuch as this is accomplished with a minimum of change in pressure or flow of the carrier gas or mobile phase. Also, the injection step establishes the initial (and best possible) peak width for the GC measurement. Thus, delivery of sample into the column should be controlled, reproducible, and rapid.

### Syringes and Switching Valves

A common method for placing samples on a GC column is to use the microliter syringe with a needle to penetrate a plastic membrane. In this method a gas-tight seal is maintained and sample is deposited into a heated zone. If liquid or solid, sample is volatilized and swept to the column and this can be accomplished by manual injections in  $\approx$  1 s. Syringe injection is a convenient and generally effective method though the thermoplastic septum develops leaks after repeated injections. Fatigue of the plastic septum limits the number of injections to  $\approx$  30 before the septum must be replaced. A second difficulty arises with impurities from off-gassing or decomposition of the septum and these are seen as so called ghost peaks or peaks in control blanks. Advances with capillary columns introduced unprecedented precision and accuracy to GC measurements and limitations with syringes became apparent. Discrimination toward high boiling point components was seen with syringe injections and techniques to remedy the failings have been developed. Sometimes thermal volatilization may lead to decomposition of samples so efforts to remove the



discrimination and decomposition motivated the use of so-called on-column injections where sample is deposited directly from the syringe into the column. Another complication with syringe injections is the introduction of particulate and reactive materials into columns. Protection is afforded by pre columns. Further information on syringe injections and the range of options for injection methods can be found in excellent reference sources. Gas samples can be injected into the column using gas-tight syringes or using rotary gas switching valves that offer enormous flexibility for GC instruments. Precision gas switching valves allow a gas sample to be measured with a precise volume and introduced into carrier gas flow without interrupting column flow. Sample is loaded into a loop and then, with a change in the valve position, is swept into the column under flow of the gas source. Heated switching valves such as those made by VICI, Inc. are also useful in the analysis of sorbent traps. When traps are heated and switched in-series with the analytical column, constituents will be thermally desorbed for GC separations. Switching valves can be automated via electronic actuators and can be incorporated into purge-and-trap methods that are useful for characterizing aqueous samples for volatile organic constituents.

### Pyrolysis

Another inlet option which is now routine in certain specific applications of material sciences is that of sample pyrolysis where solid samples are rapidly heated to a point of thermal decomposition in a reproducible manner. At temperatures in excess of 600 °C, substances such as natural or synthetic polymers thermally decompose to small molecular weight, stable substances that provide a chromatographic profile which is unique to certain materials [18]. Such an injector enlarges the application of GC to solid samples that would not normally be considered suitable for GC characterization, and pyrolysis methods have become standardized for some applications such as assaying plastics. Attachments to inlets are commercially available and serve to extend GC in forensic and industrial applications, as shown in Table 1.

## OVENS

### Conventional Designs

Liquids or solids must be converted to vapor state and maintained as a vapor throughout the GC separation. Therefore, most gas chromatographs are equipped with ovens to keep the column at temperatures from 40 to 350 °C. Exceptions are those chromatographs that are used in separating simple gases such as light hydrocarbons or permanent gases. Early gas chromatographs were equipped with isothermal ovens. Today, temperature programmed ovens allow separations of chemicals spanning a range of vapor pressures in a single analysis. Conventional ovens, unchanged in decades, consist of a

resistive wire coil that radiates into the inner volume of the oven. Heat from the resistive wire source is spread, ideally in an even manner, throughout the oven volume using a fan attached to an electric motor. A thermistor or thermocouple inside the oven is part of regulating the oven temperature via the amount of heat released by the heating element. This is controlled by the power delivered to the element and a feedback circuit to control and program the oven temperature. Efforts to create isothermal conditions, i.e. no thermal gradients inside the oven volume, are essential for reproducible chromatography and are criteria in evaluating good oven designs. Gradients in excess of a few degrees between various regions of an oven are practical in the best of oven designs and can be more than a few degrees in poorly designed ovens. One of the only systematic evaluations of GC ovens was given by Welsh and his discussion provides measures for characterizing GC ovens.

### Other Designs for Control of Column Temperature

Several alternatives to conventional ovens have been devised and may be especially helpful for short columns or instances where little space is available for a bulky, heated air oven. Two approaches have been used and include small thermal ovens and innovative column heating arrangements. Column heating based on resistive heating is compact, uses minimal power, and can decrease analysis times. These methods are based upon application of heat directly to the column or a base upon which the column is crafted or attached. The approach is unlikely to become a laboratory standard but is being explored for use in miniature or portable gas chromatographs.

### Columns

Column is one of the important part of GC which decides the separation efficiency. Columns are made up of glass or stainless steel. Stainless steel columns have the advantage of long life and can be easily handled without the fear of fragility. Glass columns have the advantage that they are inert and do not react the any kind of sample. The great disadvantages are that are highly fragile and are difficult to handle [19]. Columns can be classified

#### A. Depending on its use

**i. Analytical Column:** Analytical columns have a length of 1-1.5 meters and an outer diameter of 3-6 mm. they are packed columns and are made up of glass or stainless steel. Only small quantity of samples can be loaded on to the column.

**ii. Preparative column:** Preparative columns are larger when compared to analytical columns since large amount of sample has to be loaded. They have a length of 3 – 6 meters and outside diameter of 6-9mm.

## B. Depending on its nature

**i. Packed column:** Column are available in packed manner commercially and hence are called as packed columns. Different columns ranging from low polar nature to high polar nature are available. Examples of such columns, operating temperature.

**ii. Open tubular column or capillary column or Golay column:** They are made up of long capillary tubing of 30-90 meters in length and have uniform and narrow internal diameter of 0.025 – 0.075 cm. These are made up of stainless steel and are in the form of a coil. These columns offer least resistance to the flow of carrier gas and hence they are more efficient than packed column which offer more resistance to the flow of carrier gas. But the disadvantages are that more samples cannot be loaded.

**iii. SCOT columns (Support Coated Open Tubular Column):** This is an improved version of Golay or capillary columns. As Golay or capillary columns have small sample capacity, they can be modified into SCOT columns. These columns are also having low resistance to the flow of carrier gas but offer the advantages of more sample load or capacity.

## Detectors

Effluent from the column enters a detector where the composition of the carrier gas stream is characterized through one of several possible chemical or physical properties of molecules. The mainstays in GC have been the flame ionization detector (FID), the thermal conductivity detector (TCD) and the electron capture detector (ECD). Other commercially available detectors include the photoionization detector (PID), the nitrogen-phosphorus detector and the atomic emission detector, though these have been less prevalent historically than the FID, TCD, and ECD. Other detectors have been introduced through the years but have never become widely used in GC methods. The FID relies upon the formation of gaseous ions from organic molecules combusted in a hydrogen-air flame; the TCD is based upon changes in the heat absorbing properties of the gas effluent when the carrier gas is altered with analyte; the ECD response is governed by the ability of some molecules to attract and remove thermalized electrons. Despite long-standing conventions for the design and operation of these detectors, advances still occur.

Examples of evolutionary changes include the small FID designs and designs where gas mixing is arranged to provide optimum response. A recurring theme in advances in ECD [20] has been a nonradioactive alternative to the normal source, 10mCi of  $^{63}\text{Ni}$ . Despite promising discoveries, the radioactive source is still the favored choice. The applications of ECD illustrate the advantages of selective detectors where analyte can be

found in the presence of potentially interfering matrix.

Examples where the ECD was chosen to detect a specific chemical family over interfering backgrounds include: halocarbons in air for oceanographic tracer studies; chlorobutanol in mouse tissues and fluids; organochlorine compounds in milk products; Pesticides and other organochlorides in water. Organochlorine pesticides in edible oils and fats. In the last two decades, inexpensive mass spectrometers or mass-selective detectors (MSDs) have dramatically transformed the practice of GC. Once the purview of laboratories able to sustain the high cost of mass spectrometers and the high level of maintenance, instrument manufacturers made mass spectrometers both robust and in expensive. This development, when combined with the appreciation that analytical confidence is highest with a mass spectrometer as the detector, has resulted in a near general availability of gas chromatography/mass spectrometry (GC/MS) instrumentation. In a GC/MS analysis, a mass spectrum can be obtained continuously at fixed intervals of  $\sim 0.1$  s throughout the analysis. Consequently, a mass spectrum can be obtained for each chromatographic peak and the shoulders and baselines in the chromatogram. No other detector can provide the richness of information available in such results. Detection limits can be enhanced through the use of single ion monitoring where the mass spectrometer is used for detecting the intensity of one or a few ions. This can provide the specificity of a mass spectral pattern for response without losses in detection limit associated with scanning over unused  $m/z$  space. One revolution in the past decade has been the application of powerful desktop computers to control instrumentation and especially to control data acquisition and handling.

## Miniaturized, High-Speed, and Portable Gas Chromatographs

One area of GC that has shown vibrancy with advances during the 1990s is that of small, fast, and portable GC instruments. Though process gas chromatographs were amongst the first sophisticated analyzers placed into industrial on-site measurements, the subject has taken new significance following the burgeoning environmental movement. Making measurements where a sample is located rather than relocating samples to a centralized laboratory underlies this trend. Recently, a new journal has appeared to support these efforts, *Field Analytical Chemistry and Technology*, which includes portable GC advances.

In high-speed GC, retention times can be pushed under a few minutes or seconds with short, narrow bore columns or high flow rates. Part of the challenge in fast GC is the compressibility of the carrier gas and the necessary speed (low time constants) for subcomponents such as injectors and detectors for high-speed separations.

### Instrument Designs

An example of the size possible for small gas chromatographs is an ultimate miniature gas chromatograph created using silicon micromachining and integrated circuit processing techniques. This GC analyzer contains a 0.9m long \_ 300 mmwide\_10 mm high rectangular column coated with a 0.2-mm thick liquid phase. The injector is a 10-mm-long sampling loop with the same cross-section as the column. Dual detectors based upon a coated chemiresistor and on thermal conductivity are used. The complete system is packaged in less than 23 cm<sup>2</sup> and is 2.5mm high. Although limited in scope to the detection of ammonia and nitrogen dioxide, this miniature chromatograph offers exciting possibilities for future field instruments. One trade-off for high-speed GC is the loss of capacity due to the smaller diameter and shorter columns. Application of packed capillary columns in high-speed GC has been shown to improve capacity and selectivity. While obtaining high-speed separation for light hydrocarbons. An alternative is the multicapillary column which improved capacity while maintaining the efficiency obtained with small internal diameter columns. Injection techniques for high-speed GC must provide narrow bandwidths due to fast analysis time requirements without compromises in resolution. One means to accomplish this is through cryogenic inlets which provide narrow bandwidths and in some instances injection times can be shorter than 10ms.

### High Performance Liquid Chromatography

Drug manufacturing control requires high level and intensive analytical and chemical support of all stages to ensure the drug's quality and safety [1]. The pharmacopeia constitutes a collection of recommended procedures for analysis and specifications for the determination of pharmaceutical substances, excipients, and dosage forms that is intended to serve as source material for reference or adaptation by anyone wishing to fulfill pharmaceutical requirements. The most important analytical technique used during the various steps of drug development and manufacturing is the separation technique: High Performance Liquid Chromatography (HPLC).

The key to a proper HPLC system operation is knowledge of the principles of the chromatographic process, as well as understanding the reasons behind the choice of the components of the chromatographic systems such as column, mobile phase and detectors. A high pressure pump is required to force the mobile phase through the column at typical flow rates of 0.5-2 ml/min. The sample to be separated is introduced into the mobile phase by injection device, manual or automatic, prior to the column. The detector usually contains low volume cell through which the mobile phase passes carrying the sample components eluting from the column. There are

books describing the practicality of HPLC operation. It is expected of any proper HPLC system that is used in the pharmaceutical laboratories to produce highly accurate and precise results, due to health related issues of improper measurements. Every HPLC system must be qualified to comply with the strict demands from health authorities for high quantitative performance [21].

Quality standards in pharmaceuticals require that all instruments should be adequately designed, maintained, calibrated, and tested. The approach that has been adopted in the environment of the analytical instrument has become known as the "Four Qs": design qualification (DQ), installation qualification (IQ), operational qualification (OQ), and performance qualification (PQ). Design qualification is performed at the vendor's site, and it is representative of the way an instrument is developed and produced, usually governed by International Organization for Standardization (ISO) criteria.

The installation qualification (IQ) process can be divided into two steps: *pre-installation* and *physical installation*. During pre-installation, all information relevant to the proper installation, operation, and maintenance of the instrument is checked. Workers confirm the site requirements and the receipt of all of the parts, pieces, and manuals necessary to perform the installation of the specific HPLC unit. During physical installation, serial numbers are recorded and all fluidic, electrical, and communication connections are made for system components. Documentation describing how the instrument was installed, who performed the installation, and other various details are archived.

The operational qualification process ensures that the separate modules of a system (pump, injector, and detector) are operating according to the defined specifications such as accuracy, linearity, and precision. Specific tests are performed to verify parameters such as detector wavelength accuracy, flow rate, or injector precision.

The performance qualification (PQ) step verifies system performance as a whole. Performance qualification testing is conducted under real operating conditions in the analytical laboratory that is going to be using the instrument. In practice, sometimes operational and performance qualification blend together, particularly for linearity and precision (repeatability) tests, which can be conducted more easily at the system level.

### Modes of HPLC

There are various modes of operation of HPLC. The mechanism of interaction of the solutes with the stationary phases determines the classification of the mode of liquid chromatography.

Table 3 summarizes the variety of modes of liquid chromatography, of which Reversed Phase stands out as the most widely used mode in HPLC, therefore, the discussion will elaborate on this mode.

### Reversed Phase

Reversed phase liquid chromatography (RPLC) is considered as the method of choice for the analysis of pharmaceutical compounds for several reasons, such as its compatibility with aqueous and organic solutions as well as with different detection systems and its high consistency and repeatability. Sensitive and accurate RPLC analysis, whether in the pharmaceutical or bioanalytical field, necessitates the use of stationary phases which give symmetrical and efficient peaks. Therefore, manufacturers of stationary phases are continuously improving and introducing new RPLC products, and the selection of various types of reversed phase stationary phases is high. The needs for consistency as well as the globalization of the pharmaceutical companies require that the methods will be transferred from site to site, using either the same column brands or their equivalents. Therefore, an extensive categorization or characterization of the rich selection of stationary phases has been done in recent years (14-21).

The stationary phase in the Reversed Phase chromatographic columns is a hydrophobic support that is consisted mainly of porous particles of silica gel in various shapes (spheric or irregular) at various diameters (1.8, 3, 5, 7, 10  $\mu\text{m}$  etc.) at various pore sizes (such as 60, 100, 120, 300). The surface of these particles is covered with various chemical entities, such as various hydrocarbons (C1, C6, C4, C8, C18, etc) as can be seen in Figure 2. There are also hydrophobic polymeric supports that are used as stationary phases when there is an extreme pH in the mobile phase. In most methods used currently to separate medicinal materials, C18 columns are used, which sometimes are called ODS (octadecylsilane) or RP-18.

The more hydrophobic are the sample components the longer they stay in the column thus they are separated. The mobile phases are mixtures of water and organic polar solvents mostly methanol and acetonitrile. These mixtures contain frequently additives such as acetate, phosphate, citrate, and/or ion-pairing substances, which are surface active substances such as alkylamines as ion-pairing of anions or alkylsulfonates, ion-pairing of cations. The purpose of using such additives is to enhance efficiency and/or selectivity of the separation, mostly due to control of their retention.

The parameters that govern the retention in Reversed Phase systems are the following:

- A. The chemical nature of the stationary phase surface
- B. The type of solvents that compose the mobile phase and their ratio

C. The pH and ionic strength and additives of the mobile phase

When the effect of these parameters on the retention of the solutes is understood it is possible to manipulate them to enhance selectivity.

#### A. The chemical nature of the stationary phase

The surface of the stationary phase is described in Figure 2. The chemical nature is determined by the size and chemistry of hydrocarbon bonded on the silica gel surface, its bonding density (units of  $\mu\text{mole}/\text{m}^2$ ), and the purity and quality of the silica gel support. As a rule, the more carbons in a bonded hydrocarbon the more it retains organic solutes (as long as similar % coverage is compared). The higher the bonding density the longer the organic solutes are retained. A column is considered relatively hydrophobic if its bonding density exceeds 3  $\mu\text{mole}/\text{m}^2$ .

Very important modifiers of the stationary phase's surface are surface-active substances used as mobile phase's additives, acting as ion-pair reagents. These are substances such as tri-ethylamine or tetrabutylamine or hexyl, heptyl, octyl sulfonate. They are distributed between the mobile phase and the hydrophobic surface and cover it with either positive (alkylamines) or negative (alkylsulfonates) charges. This change of the surface into charged surface affects the retention significantly, especially on charged species in the sample.

#### B. Composition of the mobile phase

As a rule, the weakest solvent in Reversed Phase is the most polar one, water. The other polar organic solvents are considered stronger solvents, where the order of solvent strength follows more or less their dielectric properties, or polarity. The less polar the solvent added to the mobile phase, the stronger it gets, shortening the retention times.

#### PH and ionic strength of the mobile phase

When the samples contain solutes of ionizable functional groups, such as amines, carboxyls, phosphates, phosphonates, sulfates and sulfonates, it is possible to control their ionization degree with the help of buffers in the mobile phase. As a rule, the change of an ionizable molecule to an ion makes it more polar and less available to the stationary phase. For example, increasing the pH of the mobile phase above 4-5, which is the typical pKa of carboxyl groups, reduces the retention of carboxyl containing compounds. On the other hand, substances that contain amines whose pKa is around 8 will retain longer when the pH will be above 8. In most of the traditional silica-gel based stationary phases it is not possible to increase the mobile phase's pH above 8 due to hydrolysis of the silica gel. During the 2000s there have been developed extended pH stationary phases.

## Detectors

Detectors used depend upon the property of the compounds to be separated. Different detectors available are

**a. UV Detector:** This detector is based upon the light absorption characteristics of the sample. Two types of this detector are available. One is the fixed wavelength detector which operates at 254 nm where most drug compounds absorb. The other is the variable wavelength detector which can be operated from 190nm to 600nm.

**b. Refractive Index Detector:** This is a non specific or universal detector. This is not much used for analytical applications because of low sensitivity and specificity.

**c. Fluorimetric detector:** This detector is based on the fluorescent radiation emitted by some class of compounds. The excitation wavelength and emission wavelength can be selected for each compound. This detector has more specificity and sensitivity. The disadvantage is that some compounds are not fluorescent.

**d. Conductivity detector:** Based upon electrical conductivity, the response is recorded. This detector is used when the sample has conducting ions like anions and cations

**e. Amperometric detector:** This detector is based on the reduction or oxidation of the compounds when a potential is applied. The diffusion current recorded is proportional to the concentration of the compound eluted. This is applicable when compounds have functional groups which can be either oxidised or reduced. This is a highly sensitive detector.

## The Role of HPLC in Drug Analysis

The most characteristic feature of the development in the methodology of pharmaceutical and biomedical analysis during the past 25 years is that HPLC became undoubtedly the most important analytical method for identification and quantification of drugs, either in their active pharmaceutical ingredient or in their formulations during the process of their discovery, development and manufacturing.

Drug development starts with the discovery of a molecule with a therapeutic value. This can be done by high throughput screening during which separations by fast or ultra-fast HPLC are performed. At the discovery stage there can be also characterizing synthetic or natural products. Drug metabolism and pharmacokinetics (DMPK) is the step where the candidate compounds for drug are tested for their metabolism and pharmacokinetics. The studies involve use of LC-MS or LC-MS/MS.

The next stage is the development stage, where HPLC is used to characterize products of the chemical synthesis, by analyzing the active pharmaceutical ingredients (API), their impurities and/or degradation

products generated by accelerated aging. The development of formulation requires also studies of the dissolution properties of solid dosage forms as well as assays of the pharmaceutical formulations. Method for the verification of system's cleanliness during the manufacturing process are developed and used at this stage. All the HPLC methods that have been finalized at the developmental stage are validated and transferred to the manufacturing laboratories for a quality control analysis.

## Method Validation

All HPLC methods used for the development of pharmaceuticals and for the determination of their quality have to be validated. In cases whereby methods from the Pharmacopoeia's are used, it is not necessary to evaluate their suitability, provided that the analyses are conducted strictly according to the methods' intended use. In most other cases, especially in cases of modification of the drug composition, the scheme of synthesis or the analytical procedure, it is necessary to re-evaluate the suitability of the HPLC method to its new intended use.

The parameters tested throughout the method validation as defined by the ICH, USP and FDA and other health organizations are the following: Specificity or selectivity, precision (repeatability, intermediate precision, reproducibility or ruggedness), accuracy or trueness or bias, linearity range, limit of detection, limit of quantitation and robustness.

The terms *selectivity* and *specificity* are often used interchangeably. The USP monograph defines selectivity of an analytical method as its ability to measure accurately an analyte in the presence of interference, such as synthetic precursors, excipients, enantiomers and known (or likely) degradation products that might be present in the sample matrix. A method whose selectivity is verified is a "Stability Indicating Method", for details please see section 3.3.

**Precision** of a method is measured by injecting a series of standards and measuring the variability of the quantitative results. The measured standard deviation can be subdivided into three categories: repeatability, intermediate precision, and reproducibility (or ruggedness):

- Repeatability is obtained when one operator using one system over a relatively short time-span carries out the analysis in one laboratory. At least 5 or 6 determinations of three different matrices at two or three different concentrations should be done and the relative standard deviation calculated.
- Intermediate precision is a term that has been defined by ICH as the long-term variability of the measurement process and is determined by comparing the results of a method run within a single laboratory over a number of weeks. A method's intermediate precision may reflect

discrepancies in results obtained by different operators, from different instruments, with standards and reagents from different suppliers, with columns from different batches or a combination of these. Objective of intermediate precision validation is to verify that in the same laboratory the method will provide the same results once the development phase is over.

- Reproducibility (or reggedness), as defined by ICH represents the precision obtained between laboratories. The objective is to verify that the method will provide the same results in different laboratories, preparing it for the transfer to other sites.

#### Typical variations affecting a method's reproducibility are

- Differences in room temperature and humidity;
- Operators with different experience and thoroughness;
- Equipment with different characteristics, such as delay volume of an HPLC system or injection modes;
- Variations in material and instrument conditions, for example different protocols of the mobile phases preparation; changes in composition, pH, flow rate of mobile phase;
- Equipment and consumables of different ages;
- Columns from different suppliers or different batches;
- Solvents, reagents and other material with different quality

**Accuracy** of an analytical method is the extent to which test results are close to their true value. It is measured from the result of a quantitative determination of a well characterized known sample. The amount measured is compared to the known amount.

**Linearity** of an analytical method is determined by a series of three to six injections of five or more standards whose concentration's span is 80-120 percent of the expected concentration range. The response should be proportional to the concentrations of the analytes, directly or by means of a well-defined mathematical calculation. A linear

#### Examples:

Drug	Mobile Phase	Detecting Agent
Gentamycin	Chloroform : Methanol : Ammonia : Water (10:5:3:2)	Ninhydrin in pyridine – acetone mixture
Vancomycin	t-Amyl alcohol : Acetone: Water (2:1:2)	Nutrient Agar Containing Bacillus Subtilis.

- Analysis of Metabolites of Drug in Blood, urine etc.

#### Thin Layer Chromatography

- Identification of Drugs

Drug	Stationary Phase	Mobile Phase	Detecting Agent
Aminocaproic acid	Silica Gel G	Alcohol:H <sub>2</sub> O:NH <sub>3</sub> (25:3:4)	Ninhydrin in alcohol and pyridine
Ampicillin for oral suspension	Cellulose M.N – 300	Citric acid: Butyl alcohol (5:1)	Starch iodide reagent

regression equation, applied to the results, should have an intercept not significantly different from zero. If a significant non-zero intercept is obtained, it should be demonstrated that there is no effect on the accuracy of the method. The range of concentrations that an analytical method can be implemented on is the interval between the upper and lower levels (including these levels) that have been demonstrated to have the appropriate precision, accuracy and linearity. The range is normally expressed in the same units of the test results (e.g. percentage, parts per million) obtained by the analytical method.

**Limit of detection:** It is the lowest concentration of analyte in a sample that can be detected but not necessarily quantified. In chromatography the detection limit is the injected amount that results in a peak height of at least twice or three times as high as the baseline noise level.

**Limit of quantitation:** It is the minimum injected amount that gives precise measurements. In chromatography it typically requires peak heights of 10 to 20 times higher than baseline noise at precision of <10-15% RSD between results..

**Robustness** of analytical method is a measure of its capacity to remain unaffected by small but deliberate variations in method parameters and provides an indication of its reliability during normal usage.

Once validated, the methods are ready for transfer to the manufacturing quality control laboratories. Method transfer is the last stage of the validation, whereby results are tested on both the development and the manufacturing sites. Technology transfer is especially important in the era of increasing globalization of the pharmaceutical companies.

#### Applications

##### Paper Chromatography

- Separation of mixtures of drugs.
- Identification of drugs.

**Gas Chromatography**

- Checking the purity of a compound
- Presence of impurities
- Determination of mixture of drugs

- Checking the purity of a compound
- Presence of impurities
- Biopharmaceutical and Pharmacokinetic studies
- Stability studies.

**High Performance Liquid Chromatography****Table.1 Chromatographic adsorbents**

Most Strongly Adsorbent	Alumina	Al <sub>2</sub> O <sub>3</sub>
	Charcoal	C
	Florisil	MgO/SiO <sub>2</sub> (anhydrous)
	Silicagel G	silicagel + CaSO <sub>4</sub> in 1:2

**Table. 2 Eluting solvents for chromatography**

Least Eluting Power (alumina as adsorbent)	Petroleum ether (hexane; pentane)
	Cyclohexane
	Carbon tetrachloride
	Benzene
	Dichloromethane
	Chloroform
	Ether (anhydrous)
	Ethyl acetate (anhydrous)
	Acetone (anhydrous)
	Ethanol
	Methanol
	Water
	Pyridine
Greatest Eluting Power (alumina as adsorbent)	Organic acids

**Table.3 Adsorbability of organic compounds by functional group**

Least Strongly Adsorbed	Saturated hydrocarbons; alkyl halides
	Unsaturated hydrocarbons; alkenyl halides
	Aromatic hydrocarbons; aryl halides
	Polyhalogenated hydrocarbons
	Ethers
	Esters
	Aldehydes and ketones
	Alcohols
Most Strongly Adsorbed	Acids and bases (amines)

**Table 1. Examples of applications of pyrolysis GC**

Example
Lignin by pyrolysis methylation
Synthetic polymers
Fast GC
Bibliography
Rosin glycerin esters in paper
Chlorinated polyethylene structure
Coating materials: bibliography
Proteinaceous binders in paints

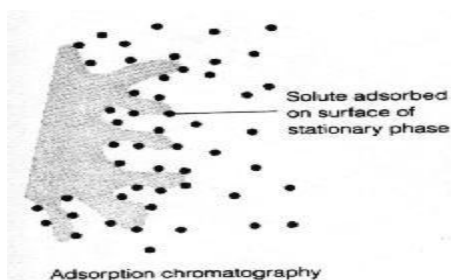
**Table 2. Examples of applications of SPME methods with GC analyses**

Example
Dimethyl sulfide in beer
Diacetyl in wine
Organochlorine compounds in water
Wine headspace compounds
Ecstasy and amphetamine in confiscated samples
Parathion in biological samples
Trimethylamine in urine
Volatile compounds in sunflower oil

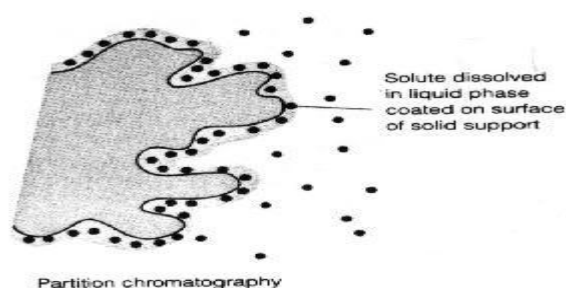
**Table 3. Summarizes the variety of modes of liquid chromatography**

Mode	Normal Phase	Reversed Phase	Ion exchange	Chiral	Affinity	Size Exclusion
Stationary Phases chemistry	Polar-hydrophilic	Non-polar-lipophilic	Ion-bonding	Chiral recognition	Bioaffinity	Sieving by size
Typical Stationary Phases	Silica, Alumina	Alkylated silica, mostly C18	Ionic functional groups on silica or polymer	Chiral groups on silica surfaces	Either substrates or biomolecules,	Gel type polymers
Typical mobile phase	Hexane; isopropanol; methylene chloride	Water; methanol; acetonitril; buffers; ion pairing agents	Water; buffers; acid; base	Two modes: aqueous and non-aqueous	Water; buffers	Two modes: aqueous and non-aqueous
Typical solutes	Fatty and oily	Almost all organic compounds	Any ion-charged compounds	Enantiomers small and large molecules	Biomolecules or their substrates	Polymers: synthetic or biological

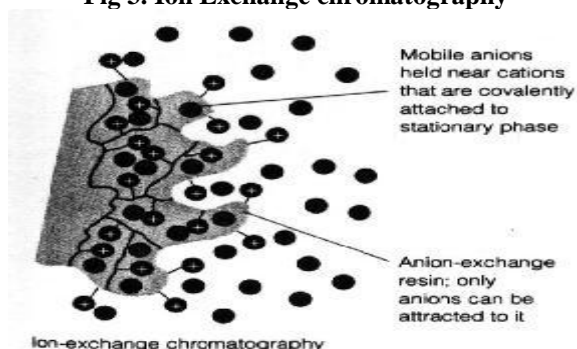
**Fig 1. Adsorption chromatography**



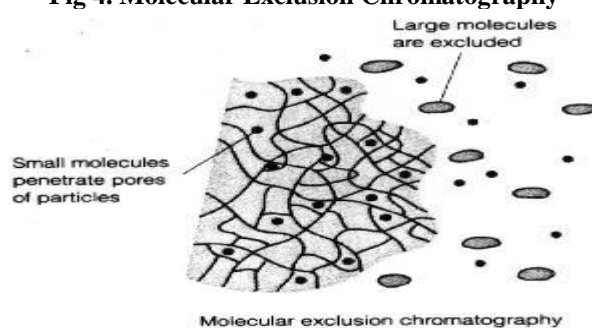
**Fig 2. Partition chromatography**



**Fig 3. Ion Exchange chromatography**

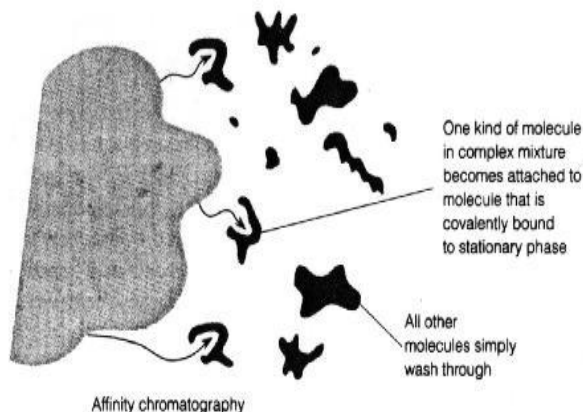


**Fig 4. Molecular Exclusion Chromatography**

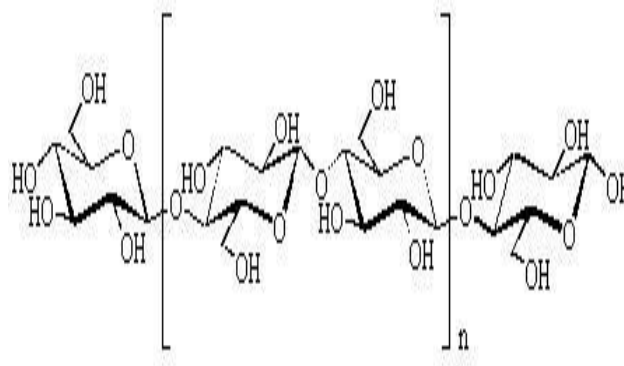




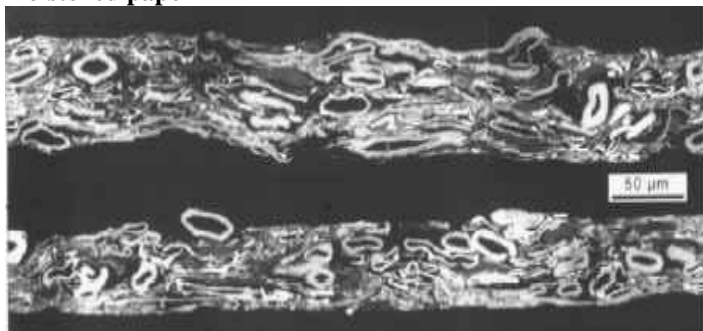
**Fig 5. Affinity Chromatography**



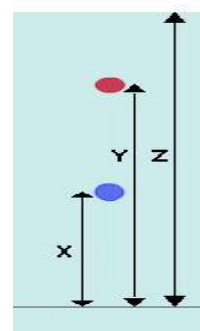
**Fig 6. The molecular structure of cellulose**



**Fig 7. A scanning electron micrograph of a cross section of moistened paper**



**Fig 8. R<sub>f</sub> Measurement**



**Fig 9. R<sub>f</sub> Measurement for a different perspective**

	<p>First, we perform chromatographic analysis on your unknown sample. We calculate the R<sub>f</sub> values of spot components in unknown.</p> <p>Here, we have a red spot with R<sub>f</sub> of 0.82 and a blue spot with R<sub>f</sub> of 0.40.</p>
	<p>We have three red dyes of known identity that may be in the unknown. In a separate experiment, we perform paper chromatography on all three simultaneously, by spotting them side by side on the plate. We get R<sub>f</sub> values, left to right, of 0.25, 0.42, and 0.83.</p> <p>By matching colours and R<sub>f</sub> values, we identify the middle dye spot as the one present in the unknown.</p>

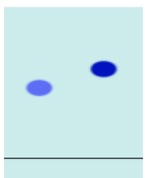
	<p>Repeating a similar experiment on the two known possible blue dye components, we obtain <math>R_f</math> values of 0.45 and 0.60 for the left and right spots, respectively.</p> <p>By matching colours and <math>R_f</math> values, we identify the left dye spot as the one present in the unknown.</p>
-----------------------------------------------------------------------------------	--------------------------------------------------------------------------------------------------------------------------------------------------------------------------------------------------------------------------------------------------------------------------------------------------------------

Fig 10. Position of the spot on a thin layer plate

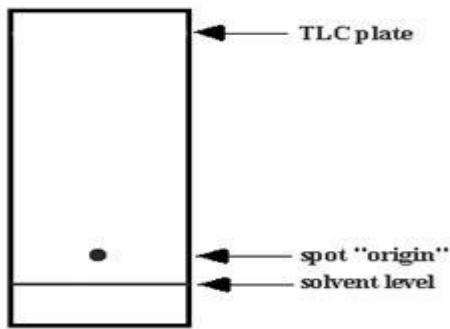


Fig 11. TLC plate showing distances traveled by the spot and the solvent

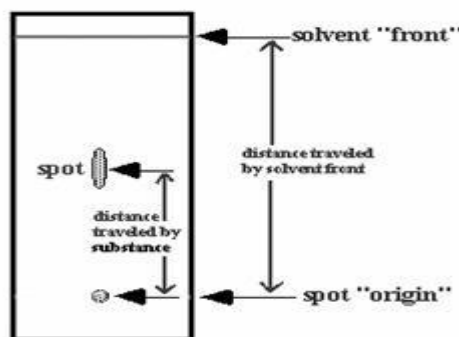


Fig 11. Developing chamber for thin layer chromatogram

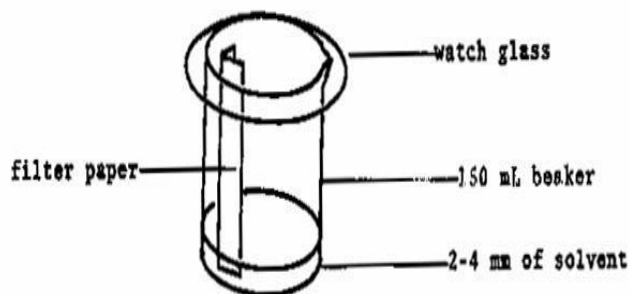


Fig 12. Two ways of using UV light to visualize the spots

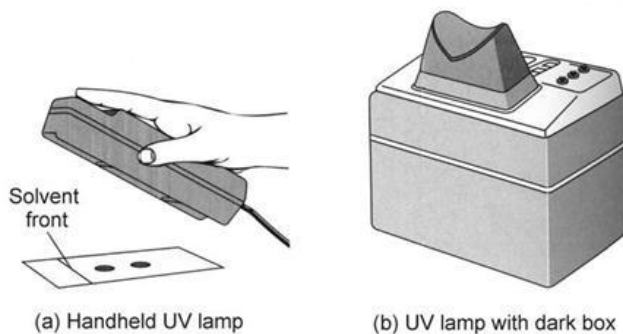


Fig 13. Modern Gas Chromatography



Fig 14. Flow diagram of Gas Chromatograph

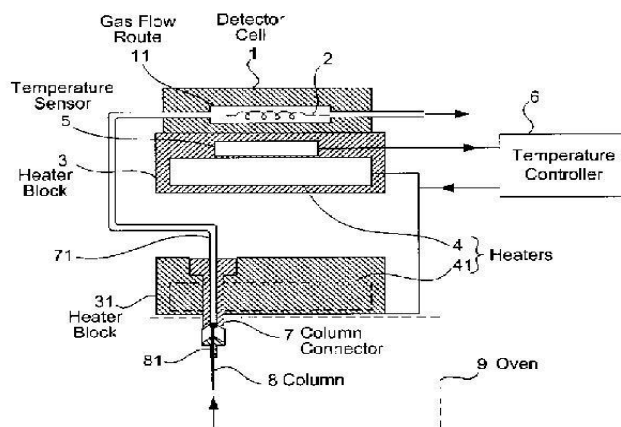
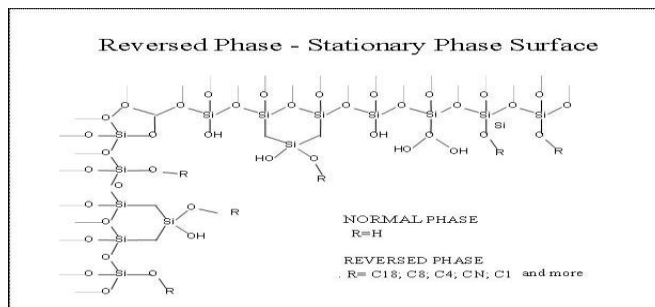
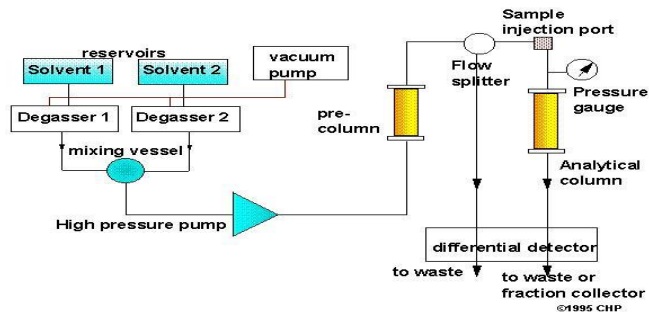


Fig 15. Flow diagram of HPLC

Fig 15. The surface of Reversed Phase stationary phases



## CONCLUSION

Chromatography is the separation of a mixture into individual components which is used in separation mixtures of drugs, identification of drugs, checking purity

of compounds, presence of impurities, isolation of drugs and for biopharmaceutical and pharmacokinetics and also as well as stability studies.

## REFERENCE

1. Still WC, et al. *Journal of Organic Chemistry*, 43(14), 1978, 2923-2925.
2. Laurence M, et al. *Experimental organic chemistry: Principles and Practice* (Illustrated ed.). WileyBlackwell, 1989: 180-185.
3. Pascal Bailon et al. *An Overview of Affinity Chromatography*, Humana Press, 2000: 256-367.
4. Fair JD and Kormos CM. *J. Chromatogr. A*, 1211(1-2), 2008, 49-54.
5. Still WC, et al. *Chem.* 43(14):1978, 2915-2920.
6. Laurence M Harwood and Christopher J. Moody. *Experimental organic chemistry: Principles and Practice* (Illustrated ed.), 2001: 54-75.
7. Fair JD and Kormos CM. *J. Chromatogr. A*, 1211(1-2), 2008, 49-54.
8. Harrison et al. *Bioseparations Science and Engineering*. Oxford University Press. New York, New York, 2003: 65-71.
9. Lloyd R Snyder and John W Dolan. *High-Performance Gradient Elution: The Practical Application of the Linear-Solvent-Strength Model*. 2006: 25-31.
10. Safranski LW and Dal Nogare S. "Gas Chromatography," *Chemical and Engineering News*, 1961: 39.
11. Ayers BO and DeFord DD. "High Speed Process Gas Chromatograph". *Analytical Chemistry*, 32, 1960, 698.
12. Guillemin CL and Martinez F. "High-Speed Gas Chromatographic Analysis in Process Chromatography". *Journal of Chromatography*, 139, 1977, 259-268.
13. James AT and AJP Martin. *Journal of Biochemistry*, 50, 1952, 679.
14. McNair HM and Miller JM. *Basic Gas Chromatography*. John Wiley & Sons, Inc., 1998: 29-52.
15. I. Halasz and HO. Gerlach. *Micropacked Columns. Analytical Chemistry*, 38, 1966, 281.
16. Guillemin CL, et al. *Rapid Gas Chromatographic Analysis on Spherosil. Journal of Chromatography*. 84, 1973, 21-36.
17. Frank D and Sandra P. *Use of Hydrogen as Carrier Gas in Capillary GC. American Laboratory*, 1999; 18.
18. Alltech Bulletin. *Bringing Speed to Gas Chromatography. Bulletin*, 328, 1995, 56-71.
19. Martin AJ. *Linear Programmed Temperature Gas Chromatography to 500°C. Edinburgh Symposium, London, Butterworths*, 1960: 208-10.
20. Emery EM and Koerner WE. *Dual Column Programmed Temperature Gas Chromatography. Analytical Chemistry*, 34, 1962, 1196-8.
21. Synovec RE, et al. *New Directions in Process Gas Chromatography. IFPAC-98 Presentation*, 1968; 1-66.