

A REVIEW PAPER ON EFFECT OF INTAKE MANIFOLD GEOMETRY ON PERFORMANCE OF IC ENGINE

Jagadishsingh Bayas¹, Anita Wankar² Prof. N.P. Jadhav³

¹ Student, Mechanical Engg. SAE Kondhwa (BK), Pune, Maharashtra, India

² Student, Mechanical Engg. JCOE Kuran, Maharashtra, India

³ Asst. Professor, Mechanical Engg. SAE Kondhwa (BK), Pune, Maharashtra, India

ABSTRACT

Intake manifold & its components play crucial role in deciding the performance of an IC engine. Engine breathing can be easily related to the intake geometry as per the different researchers worldwide. Intake manifolds affect the volumetric efficiency which ultimately makes impact up on the engine power & torque. Conventional intake manifolds have fixed geometry & thus does not cater for the demand of wide range of engine speeds. This paper reviews the work done by various prominent researchers' in the field of intake tuning & variable intake manifold. It can be easily concluded that for getting maximum volumetric efficiency throughout the engine operating speed the intake geometry needs to be changed. At lower engine speed intake length must be long for proper breathing of engine while at higher speeds intake length must be short. Considerable gain in torque & fuel economy can be observed with variable intake length manifold.

Keywords: intake manifold, intake tuning, Plenum, torque characteristics, engine performance, charging.

1. INTRODUCTION

Inlet manifold is the part of an engine that feeds the fuel/air mixture to the cylinders & it consists of air filter, intake pipe, plenum and intake runners. The duty of the intake manifold is even distribution the air fuel mixture (or just air in a CI or Direct Injection engines) to each intake port in the cylinder head. Even distribution is important to get optimum of the efficiency and performance of the engine. It may also accommodate the carburetor, throttle body, fuel injectors and other components of the engine.

Growing demand for increased engine power, torque & reduced emissions led engineers to look towards various engine components to find whether there is any scope to improvement in their design and or layout. This motivation led towards the important engine component that is intake manifold. It is now known fact that proper design of intake manifold can improve the engines performance. Intake tuning is the term which is used to define the improvement or change in intake manifold to get maximum benefit of the in cylinder motions & pressure effects by changing the geometrical aspects of the intake system. Traditional intake manifold design and optimization is based on actual physical tests of various geometries on test bench. Engine manifolds were produced & mounted on the engine & tests were conducted. This trial and error method can be effective but is very expensive and time consuming. Besides, this method cannot provide any information about the actual flow parameters inside the intake manifold. Using Intake Manifold with Symmetrical geometry has been the design by choice. Now a day's engineers try to simulate the actual real world working conditions to get more effective & accurate results. To do that several techniques involving tests and numerical simulation are been used for years. 1D engine simulations (1D CFD

simulation packages which are commercially available in market) play a major role in reducing Time, Cost and get to the best optimized design with little iterations. Some of those are Ricardo Wave, AVL Boost, Lotus Engine simulation software.

Theoretical calculations can be done to tune intake for better volumetric efficiency and engine performance with the help of Chrysler Ram theory, Acoustic tuning (Helmholtz resonator), and etc. methods.

2. LITERATURE REVIEW

First introduced by Mercedes 300SL in 1954, tuned intake manifold is not exactly a new technology in the field of IC engine. Its principle is useful to tune intake manifolds of modern day engines too. Before 1950s, engineers believed short intake manifolds were optimum for maximum engine performance. Then they discovered that under certain conditions longer intake manifolds could improve output, thanks to a so-called "supercharging effect". Different research's showed that intake manifolds with proper design can give optimum engine performance as per the designers need. Below mentioned is some of the important work done by prominent researchers across globe in the field of intake tuning.

Devendra Deshmukh et. al. done experiments on 125cc four stroke SI engine & simulated the same with the help of 1-D thermodynamic analytical model to study gas exchange process by intake & exhaust tuning. They analyzed the effect of intake & exhaust tuning on performance of the engine to find out that optimization results into the improved engine performance & improvement into the maximum vehicle speed. Experimental & simulated results were into good agreement which proves the usefulness of commercially available 1-D thermodynamic model.

[1]

Gilbert Sammut and Alex C. Alkidas in their research work (SAE technical paper 2007-01-0492) proved that the intake tuning changes volumetric efficiency mainly due to the increasing in cylinder pressure at IVC, with other effects such as gas temperature & pressure and residuals at IVC. They varied the lengths of intake & exhaust pipes in steps of 0.1m for speed range of 1200-1500 rpm. Valve timing was also varied using multiplier to increase the valve opening time without changing valve lift. No intake & exhaust pipe condition was also simulated to study the merits & demerits of the wave action present in intake & exhaust pipe.

The key findings from study were:

- Intake tuning aids breathing ability beyond the region where intake with no pipe can produce & it also has negative effect on engine performance beyond certain speed range. Therefore careful design is essential for getting maximum performance from the intake tuning.
- Intake tuning has more prominent effect on engine breathing than exhaust tuning & it exhibits positive contribution for wider range of inlet lengths for given engine speed.
- Intake and exhaust tuning are mutually independent and the net effect on the engine is a summation of their individual contributions.
- Intake and exhaust tuning are mutually independent and the net effect on the engine is a summation of their individual contributions.

[2]

L. J. Hamilton et. al. studied the effect of intake geometry on the SI engine performance in their research paper (SAE 2009-01-0302). They experimented on HONDA CBR600F4i motorcycle engine by fitting intake of different lengths in steps of 0.5m. The engine was controlled with a MOTEC™ programmable engine controller and performance parameters were measured using a Land and Sea™ water brake dynamometer coupled to the output shaft. They have calculated the engine parameters with the help of water brake dynamometer & other sophisticated measuring instruments. 1-D engine simulation code Ricardo Wave was used for computational study. The intake pressure was also measured with pressure transducer experimentally. The pressure at intake valve closure was observed to study its effect on engine performance.

The key findings from study were:

- Volumetric efficiency was seen to vary in the range of 50% to 110% and torque was seen to vary from 20 to 55 Nm over the speed range of 3,000 to 12,500 RPM.
- Intake pressure at IVC position showed dominant effect on the volumetric efficiency. Intake tuning resulted into the resonance charging which produce maximum volumetric efficiency.

- Experimental & computational investigation showed that Intake runner length has a significant effect on volumetric efficiency and torque.
- Bending intake runners to conform to packaging requirements appears to have no significant effect on volumetric efficiency or torque.
- Multiple reflections of a positive pressure wave significantly enhance engine breathing. Even though the magnitude of the positive wave decreased with each 'bounce', shorter pipes with multiple returns outperformed the primary return of a longer pipe due to flow friction. Because of this, volumetric efficiency and torque were maximized with runners of shorter lengths. [3]

Oldřich Vítěk and Miloš Polášek in their research work (SAE 2002-01-0004) analyzed the application of 1-D pipe model to study the tuned manifold systems. The influence of intake manifold length on engine parameters was examined applying 1-D pipe model. 1.3L gas engine with intake manifold of different lengths was used for experiment. The length of intake branch was varied while all other geometrical parameters were kept at a constant level. Computation was carried out for 4 different engine speeds (1550, 2000, 2500 and 3100rpm) and for the changing manifold length from 500 to 2100mm. For each engine speed, the engine model was fine-tuned for the shortest inlet branch length. Computed results were compared with experimental data. The key findings from study were:

- Comparison of computed and measured results confirmed that non-stationary 1-D pipe model is capable of capturing phenomena regarding tuned intake manifold system.
- Modeling of pipe pressure losses is another important factor it should be paid attention to. It influences mainly volumetric efficiency and all other integral parameters which depend on it.
- Simplified acoustic theory (Campbell diagram) could be used for estimation of important harmonic order regarding pressure oscillation in intake manifold. That also means that it could be used in reverse process – for the estimation of inlet branch length. Due to non-linearity, there are usually other important harmonic orders (especially for lower engine speed or shorter inlet branch length). [4]

James Taylor, David Gurney et. al. studied the intake manifold length effect on turbocharged gasoline engine & found out that induction tuning increases low speed torque up to 30%, fuel consumption improvement by 5% over baseline. They investigated 1.4 liter turbocharged gasoline engine with 4 valves per cylinder along with GT Power engine simulation tool for proper guidance for experimentation. The VLIM used for this study was designed to allow the fundamental principles to be assessed, so did not consider packaging constraints. The intake manifold was capable of changing intake lengths by inserting segments of 50mm length. [5]

Jensen Samuel, Prasad NS & et. al. in their research work on simulated one dimensional engines in AVL BOOST engine simulation software have found that the multi-cylinder turbocharged diesel engines are more responsive to intake runner length variations than naturally aspirated engines. They concluded that the given engine's performance can be improved throughout the operating speed by properly varying the intake manifold length with engine speed and with appropriate modifications to the fuel system. [6]

D N Malkhede & Hemant Khalane in their research work on 1-D thermodynamic engine model of a single cylinder 611cc standard CFR engine capable of predicting pressure waves in the intake have found out that the volumetric efficiency is the function of engine speed & intake length. As engine speed increased from 1200 rpm to 2600 rpm, improvement in volumetric efficiency can be achieved by reducing intake length linearly from 13.7 to 3.1 times stroke length. For engine with wide speed range (max speed - low idle speed greater than 3000), continuous variable intake runner length can fetch better volumetric efficiency as compared to fixed intake runner length. Intake system pressure waves can be clearly separated into two distinct phases: pressure waves during suction stroke and pressure waves during intake valve closed position. Frequency analysis of intake system pressure waves recommended that for maximum volumetric efficiency tuned intake system develops 4th order fundamental frequency during intake valve closed phase and 1st order fundamental frequency during suction stroke. [7]

4. PRINCIPLE OF RESONANCE CHARGING

An intake system works according to the principle of resonance charging, that is, high and low-pressure waves are used to charge the cylinder, in order to achieve greater volumetric efficiency. Consider the events in the intake tract.

The inlet valve opens. The piston moves downwards in the cylinder, in the direction of bottom dead centre (BDC). It creates a low-pressure wave in the vicinity of the inlet valve.

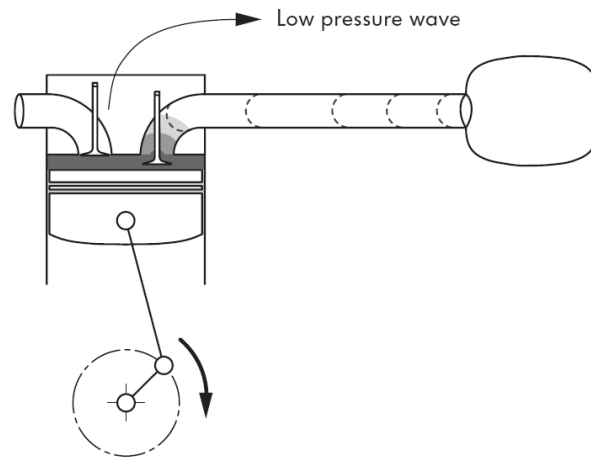

Fig. 1 Start of resonance charging

This low-pressure wave propagates itself through the resonance pipe to the other end, which protrudes into a collector. The low-pressure wave at the end of the pipe acts on the volume of air present in the collector.

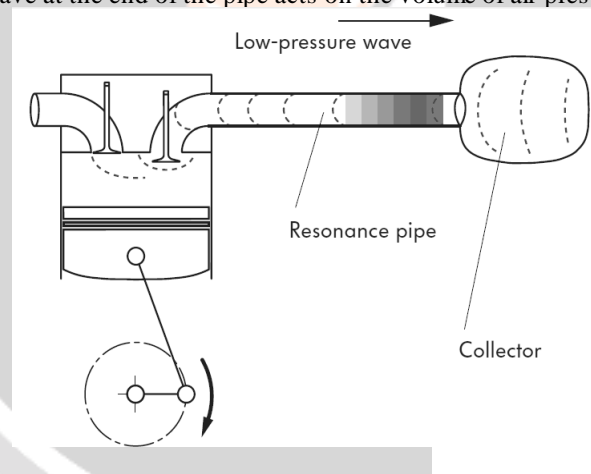

Fig. 2 Propagation of low pressure wave

The pressure of the volume of air in the collector is approximately equal to ambient air pressure. This is significantly higher than the air pressure at the open end of the resonance pipe. The low pressure now present at the end of the pipe pulls along the air mass present here. They force themselves simultaneously into the resonance pipe so that where the low-pressure wave was, an equally large high-pressure wave develops, which propagates itself towards the inlet valve.

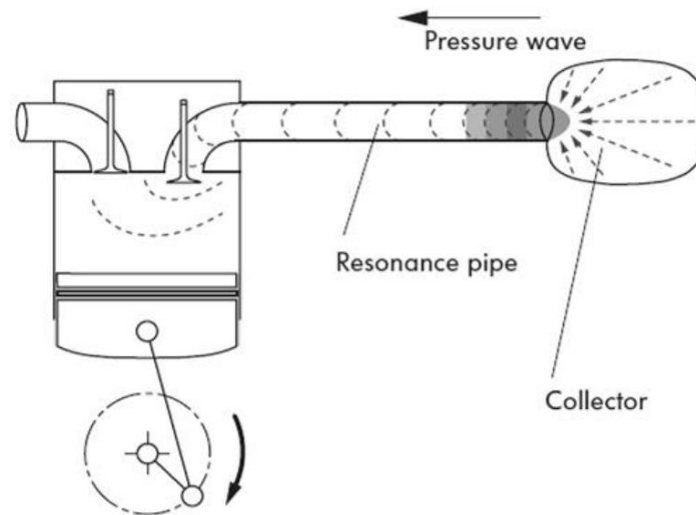

Fig. 3 Development of high pressure wave

This effect is also called as Ram-Effect charging which is further explained below.

The low-pressure wave is reflected at the open end of the pipe in the collector. This high-pressure wave travels back through the resonance pipe and pushes the air mass past the still-open inlet valve into the cylinder. This continues until the pressure before the inlet valve and the pressure in the cylinder are equal. The engine experiences “ram-effect” charging. The volumetric efficiency reaches values of about 1.0 and even above. As a result, when the inlet valve closes, backflow of the ram-effect charging into the intake pipe is prevented.

The time t (in milliseconds) required by the low and high-pressure waves to cover the distance S from the inlet valve to the collector and back is always the same because they move at the speed of sound, v .

$$t = \frac{S = \text{Constant (length of resonance pipe)}}{V = \text{Constant (Speed of sound)}}$$

But the time period during which the inlet valve is opened is dependent on engine speed. As engine speed increases, the period of time during which the inlet valve is open and air can flow into the cylinder decreases. A high-pressure wave returning through a resonance pipe designed for low engine speeds will run into an inlet valve which has already closed, “Ram-effect” charging cannot take place. It is clear that resonance pipes of different lengths are required for optimal charging at every engine speed.

4. CONCLUSION

After reviewing work of different authors as above it can be easily concluded that intake geometry make considerable impact on engine performance. The main impact is on the volumetric efficiency of the engine which ultimately affects the torque & power produced at different engine speed. The intake manifold length is an important governing factor in deciding the peak volumetric efficiency region in the engines operating speed range. Longer intake manifolds give higher torque at lower RPMs while shorter intake manifold tends to give peak torque at high engine RPM. Author’s intention is towards studying the phenomenon of intake tuning through theoretical & simulation methodologies and further validating results through experimentation.

5. ACKNOWLEDGEMENT

The authors acknowledge the institute authorities for supporting the present work to be carried out in the institute. Authors also acknowledge the various researchers whose works has been reviewed and reported in this paper.

6. REFERENCES

1. Deshmukh, D., Kumar, R., Garg, M., Nayeem, M. J., and Lakshminarasimhan, V., 'Optimisation of Gas Exchange Process on a Single Cylinder Small 4-Stroke Engine by Intake and Exhaust Tuning: Experimentation and Simulation,' SAE Paper 2004-32-0007.
2. Gilbert Sammut and Alex C. Alkidas, "Relative Contributions of Intake and Exhaust Tuning on SI Engine Breathing - A Computational Study" SAE Paper 2007-01-0492.
3. L. J. Hamilton, J. S. Cowart and J. J. Rozich, "The Effects of Intake Geometry on SI Engine Performance" SAE Paper 2009-01-0302.
4. Old ich Vitek and Miloš Polášek, "Tuned Manifold Systems – Application of 1-D Pipe Model" SAE Paper 2002-01-0004.
5. James Taylor, David Gurney and Paul Freeland et. al. "Intake Manifold Length Effects on Turbocharged Gasoline Downsizing Engine Performance and Fuel Economy" SAE Paper, 2012-01-0714.
6. Jensen Samuel, Prasad NS, and Kumarasamy Annamalai – "Effect of Variable Length Intake Manifold on a Turbocharged Multi-Cylinder Diesel Engine" SAE International, 2013-01-2756 Published 11/27/2013.
7. D N Malkhede, H Khalane – "Maximizing Volumetric Efficiency of IC Engine through Intake Manifold Tuning", SAE International, 2015-01-1738 Published 04/14/2015.
8. <http://www.chrysler300club.com/uniq/allaboutrams/ramtheory.htm>
9. Thompson M. Non Mechanical Supercharging of a Four-Stroke Diesel Engine. MS thesis, Ohio State University, 1968.

